

Chapter 1

Lesson 1.1 Practice Set

1. $2 \times 11x = (2 \times 11)x = 22x$

2. $1.35 \cdot y = 1.35y$

3. $3 \times \frac{1}{4} = \frac{3}{1} \times \frac{1}{4} = \frac{3 \times 1}{1 \times 4} = \frac{3}{4}$

4. $\frac{1}{4} \cdot z = \frac{1}{4}z$ OR $\frac{z}{4}$

5. $5m + 7$ when $m = 3$

6. $5(3) + 7 = 15 + 7 = 22$

7. $\frac{1}{3}c$ when $c = 63$

8. $\frac{1}{3}(63) = \frac{1}{3} \cdot \frac{63}{1} = \frac{63}{3} = 21$

9. $\$8.15(h)$ when $h = 43$

10. $\$8.15(43) = \350.45

11. $(k - 11) \div 8$ when $k = 43$

12. $(43 - 11) \div 8 =$

13. $32 \div 8 =$

14. 4

15. Evaluate $(-2)^2 + 3(j)$ when $j = -3$.

16. $(-2)^2 + 3(-3) =$

17. $(-2)(-2) + (-9) =$

18. $4 - 9 =$

19. -5

Evaluate the following when $a = -3$, $b = 2$, $c = 5$, and $d = -4$.

20. $2a + 3b = 2(-3) + 3(2) = -6 + 6 = 0$

21. $4c + d = 4(5) + (-4) = 20 - 4 = 16$

22. $5ac - 2b = 5(-3)(5) - 2(2) = -75 - 4 = -79$

23. $\frac{2a}{c-d} = \frac{2(-3)}{5-(-4)} = \frac{-6}{5+4} = \frac{-6}{9} = -\frac{2}{3}$

$$24. \frac{3b}{d} = \frac{3(2)}{-4} = \frac{6}{-4} = -\frac{3}{2}$$

$$25. \frac{a-4b}{3c+2d} = \frac{-3-4(2)}{3(5)+2(-4)} = \frac{-3-8}{15-8} = \frac{-11}{7} = -\frac{11}{7}$$

$$26. \frac{1}{a+b} = \frac{1}{-3+2} = \frac{1}{-1} = -1$$

$$27. \frac{ab}{cd} = \frac{(-3)(2)}{(5)(-4)} = \frac{-6}{-20} = \frac{3}{10}$$

Evaluate the following when $x = -1$, $y = 2$, $z = -3$, and $w = 4$.

$$28. 8x^3 = 8(-1)^3 = 8(-1)(-1)(-1) = -8$$

$$29. \frac{5x^2}{6z^3} = \frac{5(-1)^2}{6(-3)^3} = \frac{5(-1)(-1)}{6(-3)(-3)(-3)} = \frac{5(1)}{6(-27)} = -\frac{5}{162}$$

$$30. 3z^2 - 5w^2 = 3(-3)^2 - 5(4)^2 = 3(-3)(-3) - 5(4)(4) = 27 - 80 = -53$$

$$31. x^2 - y^2 = (-1)^2 - (2)^2 = (-1)(-1) - (2)(2) = 1 - 4 = -3$$

$$32. \frac{z^3 + w^3}{z^3 - w^3} = \frac{(-3)^3 + 4^3}{(-3)^3 - 4^3} = \frac{(-3)(-3)(-3) + (4)(4)(4)}{(-3)(-3)(-3) - (4)(4)(4)} = \frac{-27 + 64}{-27 - 64} = -\frac{37}{91}$$

$$33. 2x^2 - 3x^2 + 5x - 4 = -x^2 + 5x - 4 = -(-1)^2 + 5(-1) - 4 = -1 + (-5) - 4 = -10$$

$$34. 4w^3 + 3w^2 - w + 2 = 4(4)^3 + 3(4)^2 - (4) + 2 = 4(64) + 3(16) + 2 = 256 + 48 + 2 = 302$$

$$35. 3 + \frac{1}{z^2} = 3 + \frac{1}{(-3)^2} = 3 + \frac{1}{9} = \frac{3}{1} + \frac{1}{9} = \frac{27+1}{9} = \frac{28}{9}$$

36. The number of hours you work in a week = h .

37. The distance you travel = d .

38. The height of an object over time = h .

39. The area of a square = a .

40. The number of steps you take in a minute = s .

41. The product of six and v .
42. Four plus y minus six.
43. Sixteen squared.
44. U divided by 3 minus eight.
45. The square root of 225.
46. circumference = $2\pi r = 2(3.14)(1.25) = 7.85$ inches
47. area = length \times width = $8.5 \times 11 = 93.5$ square inches OR 93.5 in^2
48. $16(0.99) = \$15.84$
49. Let h represent the number of hours she works. Then we can write this equation.

$$\begin{aligned} \text{Hourly rate} \times \text{number of hours} &= \text{total earned} \\ 4.75h &= 124.00 \end{aligned}$$

Now solve for h .

$$\frac{4.75h}{4.75} = \frac{124.00}{4.75}$$

$$h \approx 26.11$$

Mia worked approximately 26 hours to earn \$124.00.

50. Let s = the length of one side of a square. Then area = s^2 .
Area = $10^2 = 100$ square miles OR 100 mi^2 .

Lesson 1.2 Practice Set

- $8 - (19 - (2 + 5) - 7) = 8 - (19 - (7) - 7) = 8 - (5) = 3$
- $2 + 7 \times 11 - 12 \div 3 = 2 + 77 - 4 = 75$
- $(3 + 7) \div (7 - 12) = (10) \div (-5) = -2$
- $\frac{2 \cdot (3 + (2 - 1))}{4 - (6 + 2)} - (3 - 5) = \frac{2 \cdot (3 + 1)}{4 - 8} - (-2) = \frac{8}{-4} + 2 = -2 + 2 = 0$
- $8 \cdot 5 + 6^2 = 40 + 36 = 76$
- $9 \div 3 \times 7 - 2^3 + 7 = 3 \times 7 - 8 + 7 = 21 - 8 + 7 = 20$
- $8 + 12 \div 6 + 6 = 8 + 2 + 6 = 16$
- $(7^2 - 3^2) \div 8 = (49 - 9) \div 8 = 40 \div 8 = 5$
- $\frac{jk}{j+k} = \frac{(6)(12)}{6+12} = \frac{72}{18} = 4$
- $2y^2 = 2(5)^2 = 2(25) = 50$
- $3x^2 + 2x + 1 = 3(5)^2 + 2(5) + 1 = 3(25) + 10 + 1 = 75 + 10 + 1 = 86$
- $(y^2 - x)^2 = (1^2 - 2)^2 = (1 - 2)^2 = (-1)^2 = 1$
- $\frac{4x}{9x^2 - 3x + 1} = \frac{4(2)}{9(2)^2 - 3(2) + 1} = \frac{8}{9(4) - 6 + 1} = \frac{8}{36 - 6 + 1} = \frac{8}{31}$
- $\frac{z^2}{x+y} + \frac{x^2}{x-y} = \frac{(4)^2}{1+(-2)} + \frac{(1)^2}{1-(-2)} = \frac{16}{-1} + \frac{1}{3} = \frac{-48+1}{3} = -\frac{47}{3}$
- $\frac{4xyz}{y^2 - x^2} = \frac{4(3)(2)(5)}{(2)^2 - (3)^2} = \frac{120}{4-9} = \frac{120}{-5} = -24$
- $\frac{x^2 - z^2}{xz - 2x(z-x)} = \frac{(-1)^2 - 3^2}{(-1)(3) - 2(-1)(3 - (-1))} = \frac{1-9}{-3+2(4)} = \frac{-8}{5} = -\frac{8}{5}$
- $V = \frac{s^2(h)}{3} = \frac{4^2(18)}{3} = \frac{288}{3} = 96$ cubic inches OR 96 in^3

$$18. V = \frac{s^2(h)}{3} = \frac{10^2(50)}{3} = \frac{100(50)}{3} = \frac{5000}{3} = 1,666.7 \text{ cubic feet OR } 1,666.7 \text{ ft}^3$$

$$19. V = \frac{s^2(h)}{3} = \frac{12^2(7)}{3} = \frac{144(7)}{3} = \frac{1008}{3} = 336 \text{ cubic meters OR } 336 \text{ m}^3$$

$$20. V = \frac{s^2(h)}{3} = \frac{13^2(27)}{3} = \frac{169(27)}{3} = \frac{4563}{3} = 1,521 \text{ cubic feet OR } 336 \text{ ft}^3$$

$$21. V = \frac{s^2(h)}{3} = \frac{16^2(90)}{3} = \frac{256(90)}{3} = \frac{23,040}{3} = 7,680 \text{ cubic centimeters OR } 7,680 \text{ cm}^3$$

$$22. \begin{aligned} 5 - 2 \cdot [6 - (4 + 2)] &= 5 \\ 5 - 2 \cdot [6 - 6] &= 5 \\ 5 - 2 \cdot 0 &= 5 \\ 5 - 0 &= 5 \\ 5 &= 5 \end{aligned}$$

$$23. \begin{aligned} (12 \div 4) + 10 - (3 \cdot 3) + 7 &= 11 \\ 3 + 10 - 9 + 7 &= 11 \\ 3 + 1 + 7 &= 11 \\ 4 + 7 &= 11 \\ 11 &= 11 \end{aligned}$$

$$24. \begin{aligned} 22 - [32 - 5 \cdot (3 - 6)] &= -25 \\ 22 - [32 - 5(-3)] &= -25 \\ 22 - [32 + 15] &= -25 \\ 22 - 47 &= -25 \\ -25 &= -25 \end{aligned}$$

$$25. \begin{aligned} 12 - (8 - 4) \cdot 5 &= -8 \\ 12 - 4 \cdot 5 &= -8 \\ 12 - 20 &= -8 \\ -8 &= -8 \end{aligned}$$

$$26. x^2 + 2x - xy = (250)^2 + 2(250) - (250)(-120) = 62,500 + 500 + 30,000 = 93,000$$

$$27. (xy - y^4)^2 = ((0.02)(-0.025) - (-0.025)^4)^2 = (-0.0005 - 0.000000390625)^2 = (0.0004996)^2 = 0.0000002496$$

$$28. \frac{x+y-z}{xy+yz+xz} = \frac{\frac{1}{2} + \frac{3}{2} - (-1)}{\left(\frac{1}{2}\right)\left(\frac{3}{2}\right) + \left(\frac{3}{2}\right)(-1) + \left(\frac{1}{2}\right)(-1)} = \frac{3}{\frac{3}{4} - \frac{3}{2} - \frac{1}{2}} = \frac{3}{\frac{3-6-2}{4}} = \frac{3}{\frac{-5}{4}} = \frac{3}{1} \left(\frac{4}{-5}\right) = -\frac{12}{5}$$

$$29. \frac{(x+y)^2}{4x^2-y^2} = \frac{(3+(-5d))^2}{4(3)^2 - (-5d)^2} = \frac{9-30d+25d^2}{36+25d^2}$$

$$30. V = \frac{4}{3}\pi r^3 = \frac{4}{3}\pi(9)^3 = \frac{4}{3}\pi(729) = 3,053.63 \text{ cubic centimeters OR } 3,053.63 \text{ cm}^3$$

$$31. x = -1, \text{ so } -9x + 2 = -9(-1) + 2 = 9 + 2 = 11$$

$$32. A = \frac{h}{2}(a+b) = \frac{8}{2}(10+15) = 4(25) = 100 \text{ square centimeters OR } 100 \text{ cm}^2$$

$$33. A = \pi r^2 = \pi(17)^2 = 289\pi \approx 907.46 \text{ square inches OR } 907.46 \text{ in}^2$$

Lesson 1.3 Practice Set

1. Sixteen more than a number = $x + 16$
2. The quotient of h and 8 = $\frac{h}{8}$
3. Forty-two less than $y = y - 42$
4. The product of k and three = $3k$
5. The sum of g and $-7 = g + (-7)$
6. r minus 5.8 = $r - 5.8$
7. 6 more than 5 times a number = $5x + 6$
8. 6 divided by a number minus 12 = $\frac{6}{x-12}$
9. A number divided by $-11 = \frac{x}{-11}$
10. 27 less than a number times four = $4x - 27$
11. The quotient of 9.6 and $m = \frac{9.6}{m}$
12. 2 less than 10 times a number = $10x - 2$
13. The quotient of d and five times $s = \frac{d}{5s}$
14. 35 less than $x = x - 35$
15. The product of 6, -9 , and $u = (6)(-9)u$ OR $-54u$
16. $j - 9 =$ a number minus 9
17. $\frac{n}{14} =$ a number divided by 14
18. $17 - a =$ a number less than 17
19. $3l - 16 =$ three times a number minus sixteen

20. $\frac{1}{2}(h)(b)$ = one-half the product of two numbers
21. $\frac{b}{3} + \frac{z}{2}$ = a number, b , divided by three added to a number, z , divided by 2
22. $4.7 - 2f$ = four and seven tenths less the product of two and a number
23. $5.8 + k$ = the sum of five and eight tenths and a number
24. $2l + 2w$ = two times a number, l , plus two times a number, w
25. Let u represent the unit cost of the items purchased. Then
- $$u = \frac{\text{total cost}}{\text{number of objects}} = \frac{14.50}{n}$$
26. Let a = area of the square and s = length of one side. Then $a = s^2$
27. Let l = the length of ribbon and let f = number of outfits. (Note: any variable will work, but I avoided o because of the similarity with 0.)
- $$l = 15f$$
28. Let t = total chocolate squares and s = squares that have been eaten. (Note: using the variable e is not a good idea, as in mathematics, e represents a number, i.e. $e \approx 2.718281828\dots$)
- $$t = 16 - s$$
29. There are many possible answers. One such example is below.
Let h = the number of helium balloons
Sally has a number of helium balloons, h , and her mom buys 9 more for her.
30. The variable is already defined as m . The expression would be written as $\frac{7}{m} - \frac{m}{7}$.
31. a) The pattern is that to get to the next amount, one should start with 65 games packaged for the first worker and add 22 games packaged for each additional worker.
b) The expression for the number of games packaged would be $65 + 22(w-1)$ if w = the number of workers.
32. a) The total pay is 15 dollars plus 7 dollars for every hour.
b) If h = the number of hours, then the expression becomes $15 + 7(h-1)$.

33. a) To find the number of bacteria, raise the number of hours as a power of 2.
 b) Let b = number of bacteria and h = number of hours. Then $b = 2^h$.
34. a) Let s = the number of seats on the ferris wheel. Then the number of people, p , on the ferris wheel is $p = 2s$.
 b) If there are 17 seats filled, then $p = 2(17) = 34$ people.
35. The expression was $28 \times p$, where p = the number of people. If $p = 2,518$, then the amount of revenue is $28(2,518) = \$70,504$.
36. $10 + 6 \div 2 - 3 = 5$
 $(10 + 6) \div 2 - 3 = 5$
37. $5x^2 - 4y$ when $x = -4$ and $y = 5$
 $5(-4)^2 - 4(5) = 5(16) - 20 = 80 - 20 = 60$
38. $\frac{x^2 y^3}{x^3 + y^2}$ when $x = 2$ and $y = -4$
 $\frac{x^2 y^3}{x^3 + y^2} = \frac{2^2(-4)^3}{2^3 + (-4)^2} = \frac{4(-64)}{8+16} = \frac{-256}{24} = -\frac{32}{3}$
39. $2 - (t - 7)^2 \times (u^3 - v)$ when $t = 19$, $u = 4$, and $v = 2$
 $2 - (19 - 7)^2 \times (4^3 - 2) = 2 - (12)^2 \times (64 - 2) = 2 - 144 \times 62 = 2 - 8928 = -8926$
40. $2 - (19 - 7)^2 \times (4^3 - 2) = 2 - (12)^2 \times (64 - 2) = 2 - 144 \times 62 = 2 - 8928 = -8926$

Lesson 1.4 Practice Set

1. The value (or multiple values) that make the equation or inequality true.
2. An algebraic equation uses an equal sign, and an algebraic inequality uses the symbols $<$, $>$, \leq , \geq , or \neq .
Equation: $3x + 4 = 12$
Inequality: $2y - 5 < -34$
3. $<$, $>$, \leq , \geq , and \neq
4. let y = the amount of yard
Then the amount Peter earns = $0.20(\text{the amount of yard}) + \text{the charge per job}$
 $25 = 0.20y + 10$
5. let p = number of people
Then total costs = $4(\text{the number of people}) + \text{initial charge}$
 $324 = 4p + 200$
6. let m = the number of miles
Then total rental cost = $0.45(\text{the number of miles}) + \text{the initial charge}$
 $100 = 0.45m + 55$
7. let b = total number of blocks
Then the total number of blocks = the amount Peter already has + the amount Nadia gives him
 $b = 7 + 4$
8. let p = the number of passengers
Then $p \leq 65$.
9. let n = the first integer
Then the sum of the integers = the first integer + the next integer = $n + (n + 1)$.
So $n + (n + 1) < 54$.
10. Let I = the interest earned, r = the annual interest rate, and p = the amount of money invested, and t = time (in years). We do not know p , and we know $I \geq 250$, $r = 0.05$, and $t = 1$.
 $0.05p \geq 250$
11. Let h = the number of hamburgers you can eat.
Then $0.49h \leq 3$

To check to see if a value is a solution, follow these steps.

1. Substitute the value in for the variable into the original equation.
2. Keep one side of the equation or inequality is unchanged.

3. Simplify the other side until it is a single number.
4. Check to see if the values make a true statement.
5. If the statement is true, the value is a solution. If the statement is false, double-check your work. If the work is good, then the value is not a solution.

12. $a = -3$; $4a + 3 = -9$
 Check: $4(-3) + 3 = -9$
 $-12 + 3 = -9$
 $-9 = -9$ ✓

13. $x = \frac{4}{3}$; $\frac{3}{4}x + \frac{1}{2} = \frac{3}{2}$
 Check: $\frac{3}{4}\left(\frac{4}{3}\right) + \frac{1}{2} = \frac{3}{2}$
 $\frac{12}{12} + \frac{1}{2} = \frac{3}{2}$
 $\frac{2}{2} + \frac{1}{2} = \frac{3}{2}$
 $\frac{3}{2} = \frac{3}{2}$ ✓

14. $y = 2$; $2.5y - 10.0 = -5.0$
 Check: $2.5(2) - 10.0 = -5.0$
 $5 - 10.0 = -5.0$
 $-5.0 = -5.0$ ✓

15. $z = -5$; $2(5 - 2z) = 20 - 2(z - 1)$
 In this case, you will have to simplify both sides.
 Check: $2(5 - 2(-5)) = 20 - 2((-5) - 1)$
 $2(5 + 10) = 20 - 2(-6)$
 $2(15) = 20 + 12$
 $30 = 32$ ✗

16. $x = 12$; $2(x + 6) \leq 8x$
 Check: $2(12 + 6) \leq 8(12)$
 $2(18) \leq 96$
 $36 \leq 96$ ✓

$$17. z = -9; 1.4z + 5.2 > 0.4z$$

$$\text{Check: } 1.4(-9) + 5.2 > 0.4(-9)$$

$$-12.6 + 5.2 > -3.6$$

$$-7.2 > -3.6 \quad \times$$

$$18. y = 40; -\frac{5}{2}y + \frac{1}{2} < -18$$

$$\text{Check: } -\frac{5}{2}(40) + \frac{1}{2} < -18$$

$$\frac{-200}{2} + \frac{1}{2} < \frac{-36}{2}$$

$$\frac{-199}{2} < \frac{-36}{2} \quad \checkmark$$

$$19. t = 0.4; 80 \geq 10(3t + 2)$$

$$\text{Check: } 80 \geq 10(3(0.4) + 2)$$

$$80 \geq 10(1.2 + 2)$$

$$80 \geq 10(3.2)$$

$$80 \geq 32 \quad \checkmark$$

$$20. m + 3 = 10$$

$$\quad -3 \quad -3$$

$$m = 7$$

$$21. \frac{6 \times k}{6} = \frac{96}{6}$$

$$k = 16$$

$$22. 9 - f = 1$$

$$\quad -9 \quad -9$$

$$-f = 1 - 9$$

$$-f = -8$$

$$f = 8$$

$$23. \frac{8h}{8} = \frac{808}{8}$$

$$h = 101$$

$$24. a + 348 = 0$$

$$\quad -348 \quad -348$$

$$a = -348$$

25. There are many possible solutions. The inequality is $2.5b + 1.75f \leq 25.00$, where b = the number of burgers and f = the number of fries

If $b = 5$ and $f = 5$, then $2.5(5) + 1.75(5) \leq 25$

$$12.5 + 6.25 \leq 25$$

$$19 \leq 25$$

If $b = 6$ and $f = 5$, then $2.5(6) + 1.75(5) \leq 25$

$$15 + 6.25 \leq 25$$

$$21.25 \leq 25$$

If $b = 5$ and $f = 7$, then $2.5(5) + 1.75(7) \leq 25$

$$12.5 + 12.75 \leq 25$$

$$24.75 \leq 25$$

26. $\frac{1.59a}{1.59} < \frac{7}{1.59}$

$$a < 4.40 \text{ lbs}$$

27. Let s = number of sliders

$$\text{Then } s = 5(7) = 35 \text{ sliders}$$

28. Let l = the price of the Lexus

$$\text{Then } \frac{0.27l}{0.27} = \frac{15000}{0.27}$$

$$l = \$55,555.56$$

29. Let s = the amount of sales

$$\text{Then you want to know when } 1000 + 0.06s > 1200 + 0.05s$$

$$1000 + 0.06s > 1200 + 0.05s$$

$$-0.05s \qquad -0.05s$$

$$1000 + 0.01s > 1200$$

$$-1000 \qquad -1000$$

$$\frac{0.01s}{0.01} > \frac{200}{0.01}$$

$$s > 20,000$$

30. $\frac{1.75f}{1.75} \leq \frac{25}{1.75}$

$$f \leq 14$$

31. 17 less than a number is 65

$$x - 17 = 65$$

$$\begin{aligned} 32. \quad & 3^4 \div (9 \times 3) + 6 - 2 \\ & 81 \div (9 \times 3) + 6 - 2 \\ & 81 \div 27 + 6 - 2 \\ & 3 + 6 - 2 \\ & 7 \end{aligned}$$

$$33. \quad A = \frac{1}{2} \cdot b \cdot h = \frac{1}{2}bh$$

$$\begin{aligned} 34. \quad & V = 4x(10 - x)^2 \text{ when } x = 2 \\ & V = 4(2)(10 - 2)^2 \\ & V = 8(8)^2 \\ & V = 8(64) \\ & V = 512 \text{ cubic inches} \end{aligned}$$

Lesson 1.5 Practice Set

- $y = \frac{5}{6}x - 2$ becomes $f(x) = \frac{5}{6}x - 2$
- To allow one to easily decipher between the equations
- domain – all the possible input values for the independent variable
- This is false. Range – all the possible input values for the dependent variable

5.

x	$f(x)$	Work shown
-5	-27	$-(x)^2 - 2 = -(-5)^2 - 2 = -25 - 2 = -27$
-4	-18	$-(x)^2 - 2 = -(-4)^2 - 2 = -16 - 2 = -18$
-3	-11	$-(x)^2 - 2 = -(-3)^2 - 2 = -9 - 2 = -11$
-2	-6	$-(x)^2 - 2 = -(-2)^2 - 2 = -4 - 2 = -6$
-1	-3	$-(x)^2 - 2 = -(-1)^2 - 2 = -1 - 2 = -3$
0	-2	$-(x)^2 - 2 = -(0)^2 - 2 = 0 - 2 = -2$
1	-3	$-(x)^2 - 2 = -(1)^2 - 2 = -1 - 2 = -3$
2	-6	$-(x)^2 - 2 = -(2)^2 - 2 = -4 - 2 = -6$
3	-11	$-(x)^2 - 2 = -(3)^2 - 2 = -9 - 2 = -11$
4	-18	$-(x)^2 - 2 = -(4)^2 - 2 = -16 - 2 = -18$
5	-27	$-(x)^2 - 2 = -(5)^2 - 2 = -25 - 2 = -27$

- Let p = the price of the car and w = the number of weeks
Then $p = 515.85 + 62w$
 - The domain cannot be all real numbers because the price would not be negative.
 - $$p = 515.85 + 62w$$

$$1795 = 515.85 + 62w$$

$$\begin{array}{r} -515.85 \quad -515.85 \\ \hline 1279.15 = 62w \\ \hline 62 \quad 62 \\ \hline w = 20.6 \end{array}$$

She will need to save approximately 21 weeks.
- Let t = total earned and h = the number of hours
Then the equation would be $t = 10h$
The domain would be all the values that h could be, or the number of hours Dustin would work. Since it does not make sense for Dustin to work negative hours, the domain is $h \geq 0$, or all real numbers greater than or equal to 0.

8. Let c = the total cost to the customer for tutoring and h = the number of hours Maria tutors.
The equation would be $c = 25h + 15$.
As in the previous item, Maria would not work negative hours, so domain is $h \geq 0$.
9. $f(x) = 15x - 12$; Since there are no variables in the denominator, or no variables under a radical sign, there are no restrictions on the domain. The domain is all real numbers, or $-\infty < x < \infty$.
10. $f(x) = 2x^2 + 5$; Since there are no variables in the denominator, or no variables under a radical sign, there are no restrictions on the domain. The domain is all real numbers, or $-\infty < x < \infty$.
11. $f(x) = \frac{1}{x}$; Since there is a variable in the denominator, the domain can be any number that would not make the denominator 0, since dividing by zero is undefined. Therefore, the domain is all real numbers except $x = 0$. Another way to write it is domain = $-\infty < x < 0$ AND $0 < x < \infty$.

12. We will create a table to determine the range.

x (domain)	Work shown	y (range)
-2	$x^2 - 5 = (-2)^2 - 5 = 4 - 5 = -1$	-1
-1	$x^2 - 5 = (-1)^2 - 5 = 1 - 5 = -4$	-4
0	$x^2 - 5 = (0)^2 - 5 = 0 - 5 = -5$	-5
1	$x^2 - 5 = (1)^2 - 5 = 1 - 5 = -4$	-4
2	$x^2 - 5 = (2)^2 - 5 = 4 - 5 = -1$	-1

13. We will create a table to determine the range.

x (domain)	Work shown	y (range)
-2.5	$2x - \frac{3}{4} = 2(-2.5) - \frac{3}{4} = -5 - \frac{3}{4} = -5\frac{3}{4}$ OR $-\frac{23}{4}$	$-\frac{23}{4}$
1.5	$2x - \frac{3}{4} = 2(1.5) - \frac{3}{4} = 3 - \frac{3}{4} = 2\frac{1}{4}$ OR $\frac{9}{4}$	$\frac{9}{4}$
5	$2x - \frac{3}{4} = 2(5) - \frac{3}{4} = 10 - \frac{3}{4} = 9\frac{1}{4}$ OR $\frac{37}{4}$	$\frac{37}{4}$

14. Let h = the number of hours worked

x (domain)	Work shown ($6.50h$)	y (range)
5	$6.50(5) = 32.50$	\$32.50
10	$6.50(10) = 65.00$	\$65.00
15	$6.50(15) = 97.50$	\$97.50
20	$6.50(20) = 130.00$	\$130.00
25	$6.50(25) = 162.50$	\$162.50
30	$6.50(30) = 195.00$	\$195.00

15.

h (height)	Work shown ($\frac{1}{2}8b$)	A (area)
1	$\frac{1}{2}8(1) = 4$	4 cm^2
2	$\frac{1}{2}8(2) = 8$	8 cm^2
3	$\frac{1}{2}8(3) = 12$	12 cm^2
4	$\frac{1}{2}8(4) = 16$	16 cm^2
5	$\frac{1}{2}8(5) = 20$	20 cm^2
6	$\frac{1}{2}8(6) = 24$	24 cm^2

16.

x (domain)	Work shown ($\sqrt{2x+3}$)	$f(x)$ (range)
-1	$\sqrt{2x+3} = \sqrt{2(-1)+3} = \sqrt{-2+3} = \sqrt{1} = \pm 1$	± 1
0	$\sqrt{2x+3} = \sqrt{2(0)+3} = \sqrt{0+3} = \pm\sqrt{3}$	$\pm\sqrt{3}$
1	$\sqrt{2x+3} = \sqrt{2(1)+3} = \sqrt{2+3} = \pm\sqrt{5}$	$\pm\sqrt{5}$
2	$\sqrt{2x+3} = \sqrt{2(2)+3} = \sqrt{4+3} = \pm\sqrt{7}$	$\pm\sqrt{7}$
3	$\sqrt{2x+3} = \sqrt{2(3)+3} = \sqrt{6+3} = \sqrt{9} = \pm 3$	± 3
4	$\sqrt{2x+3} = \sqrt{2(4)+3} = \sqrt{8+3} = \pm\sqrt{11}$	$\pm\sqrt{11}$
5	$\sqrt{2x+3} = \sqrt{2(5)+3} = \sqrt{10+3} = \pm\sqrt{13}$	$\pm\sqrt{13}$

17. The rule is $y = f(x) = x^2$.

18. Let h = the number of hours and c = the cost. Then the function is $c = 15 + 5h$.

19. The function rule is $y = \frac{24}{2x}$.

20. To cut a ribbon into x pieces, the function is $f(x) = x - 1$

21. Let c = total charge and let h = the number of hours worked. Since the charge is a function of the hours, $c = f(h)$.
 The function then becomes $f(h) = 25h + 40$.
 To find out what Solomon earns for 3 hours, we want $f(3) = 25(3) + 40 = 75 + 40 = 115$.
22. Let b = the number of bracelets. Then $2500 = 12.50b$. So we need to solve for b .

$$\frac{2500}{12.50} = \frac{12.50b}{12.50}$$

$$b = 200$$
 She must sell 200 bracelets to break even.
23. There are many possible solutions. One scenario is an airplane flying. The plane can travel to the left or right as much as it wants, but cannot reach zero (while flying), or else it would crash.
24. $23 > 21.999$
25. the quotient of 96 and 4 is $g = \frac{96}{4} = g$
26. 11 minus b is at least $77 = 11 - b \geq 77$
27. $\frac{13(k)}{13} = \frac{169}{13}$
 $k = 13$

Quiz

- Let n = the number of books and c = the cost. The function rule is $c = 4.75 + 0.5(n - 1)$.
- $84 \div [(18 - 16) \times 3] = 84 \div [2 \times 3] = 84 \div 6 = 14$
- $\frac{2}{3}(y + 6)$ when $y = 3$

$$\frac{2}{3}(3 + 6) = \frac{2}{3}(9) = 6$$
- $y = \frac{1}{4}x^2$ becomes $f(x) = \frac{1}{4}x^2$
- Let t = total cost
 The $t = 29.99(6) + 22.99(3) = 179.94 + 68.97 = \248.91

Lesson 1.6 Practice Set

1.

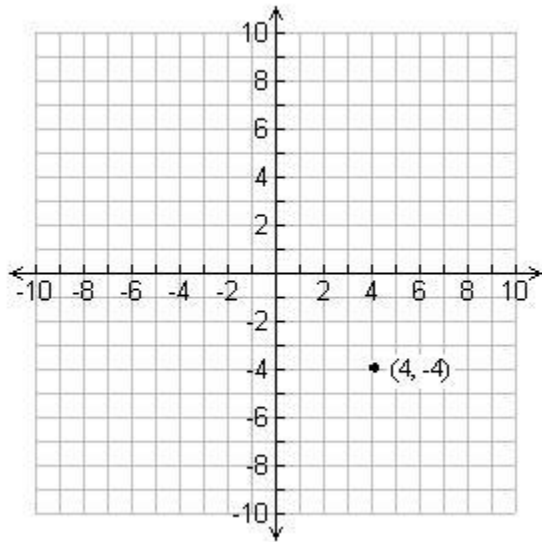

2.

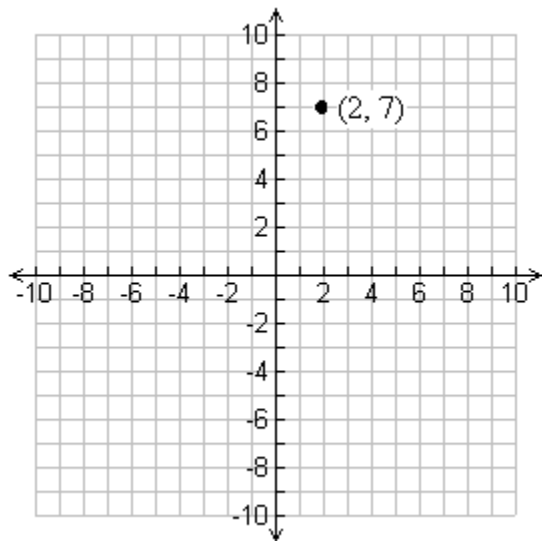

3.

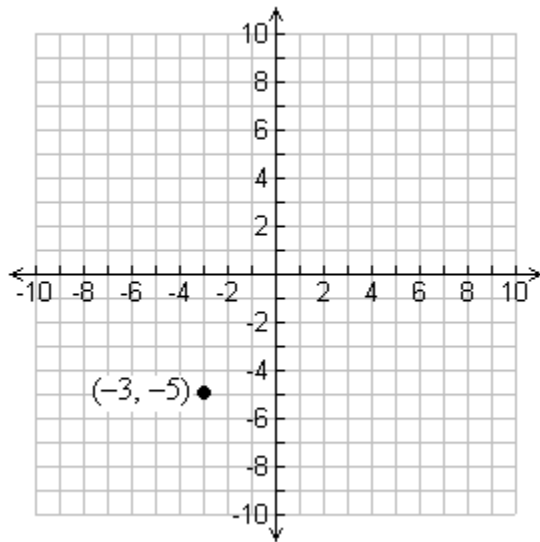

4.

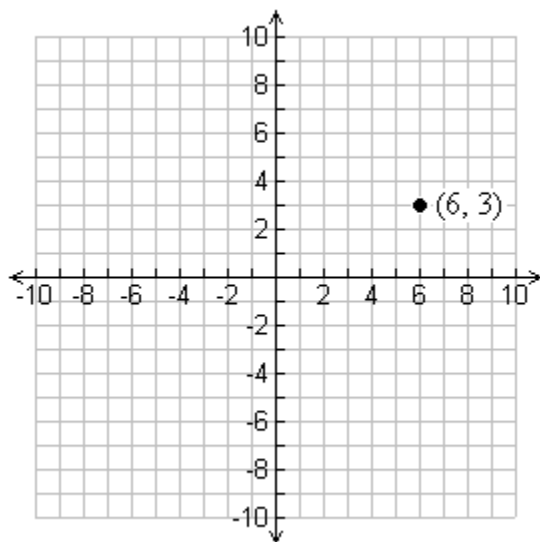

5.

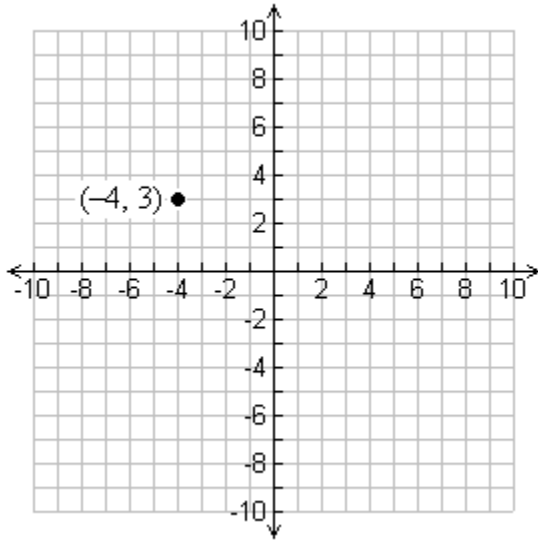

6. $a(-6, 4)$
 $b(7, 6)$
 $c(-8, -2)$
 $d(4, -7)$
 $e(5, 0)$

7.

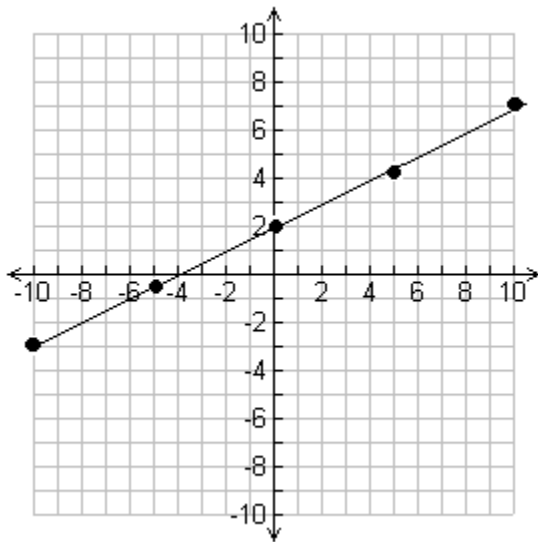

8.

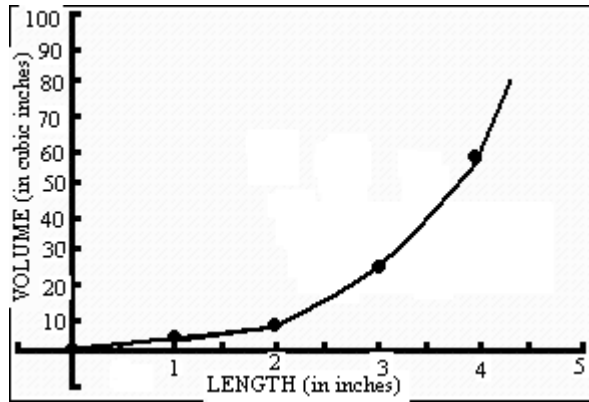

9.

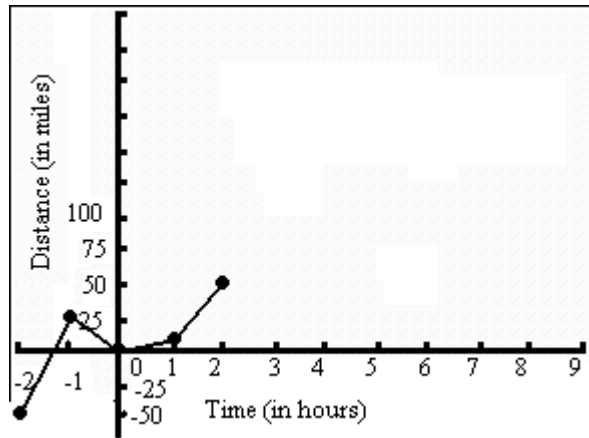

10.

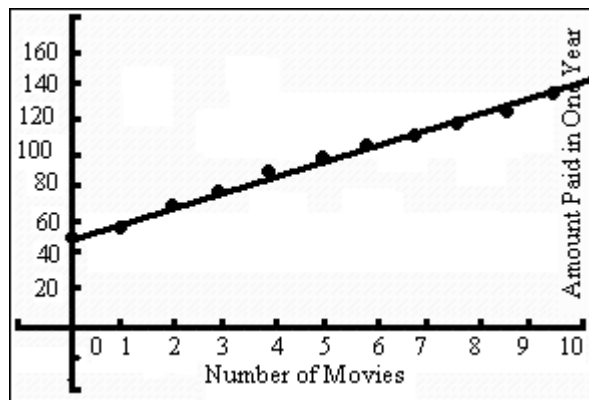

11. Create a table of values to see what the function is doing.

x	$y = (x - 2)^2$	y
-4	$(-4 - 2)^2 = 36$	36
-3	$(-3 - 2)^2 = 25$	25
-2	$(-2 - 2)^2 = 16$	16
-1	$(-1 - 2)^2 = 9$	9
0	$(0 - 2)^2 = 4$	4
1	$(1 - 2)^2 = 1$	1
2	$(2 - 2)^2 = 0$	0
3	$(3 - 2)^2 = 1$	1
4	$(4 - 2)^2 = 4$	4
5	$(5 - 2)^2 = 9$	9
6	$(6 - 2)^2 = 16$	16
7	$(7 - 2)^2 = 25$	25

Now we can graph the function based on the table.

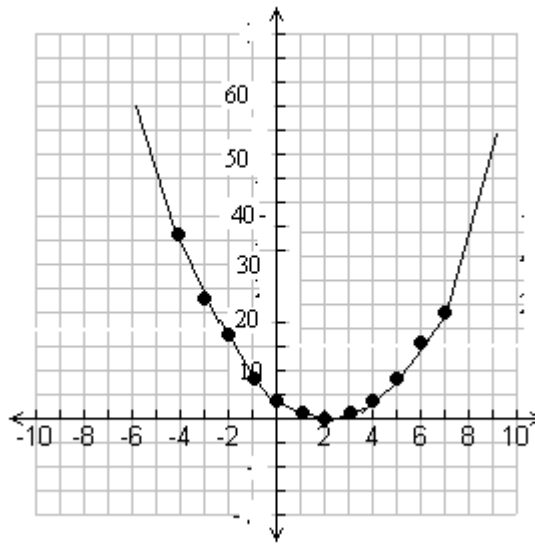

12. Create a table to see what the function is doing.

x	$y = 3.2^x$	y (approximate)
-3	3.2^{-3}	0.0305
-2	3.2^{-2}	0.0977
-1	3.2^{-1}	0.3125
0	3.2^0	1
1	3.2^1	3.2
2	3.2^2	10.24
3	3.2^3	32.77
4	3.2^4	104.86

Now we can plot the points and connect with a smooth curve.

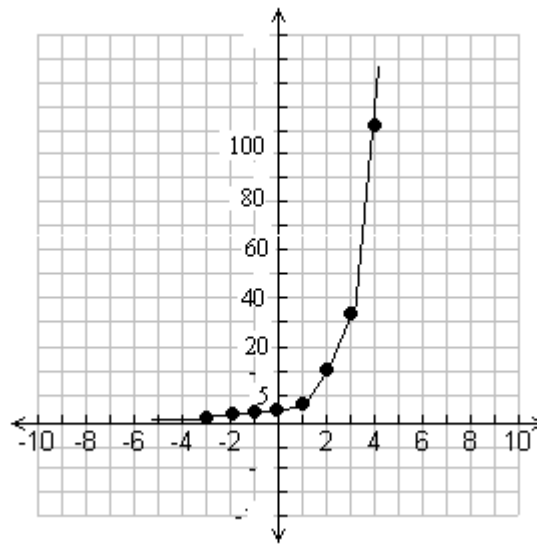

13. Since every x -coordinate has only one y -coordinate, it is a function.

14. Since each x -coordinate has two y -coordinates, it is not a function.

15. Since age 25 has two jobs (4 and 7), it is not a function.

16. Since every x -coordinate has only one y -coordinate, it is a function.

17. The rule for the graphed relation is $y = x^2$.

18. The rule for the graphed relation is $y = \sqrt{x}$.

19. 1. 27%, 2. 35.5%, 3. 22.5%, 4. 23%

20. 1. 63 years, 2. 69 years, 3. 74 years, 4. 76 years

21. 1. \$19,000, 2. \$56,000, 3. \$10,000, 4. \$11,000, 5. \$36,000

22. Since the graph passes the Vertical Line Test, it is a function.

23. Since the graph does not pass the Vertical Line Test, it is not a function.

24. Let m = money taken in. Then the amount is $m = 12(1296) = \$15,552$.

25. Since there is still $\frac{2}{3}$ of the students in the room, that means that the 25 that left account for $\frac{1}{3}$ of the total. Then you can set up an equation by asking: 25 is $\frac{1}{3}$ of what number? Let x represent the total number of students.

$$25 = \frac{1}{3}x$$

$$x = 25(3) = 75 \text{ students}$$

26. $\frac{x^2+9}{y+2}$ when $y = 3$ and $x = 4$

$$\frac{x^2+9}{y+2} = \frac{(4)^2+9}{(3)+2} = \frac{16+9}{3+2} = \frac{25}{5} = 5$$

27. Since $r = 7$ inches, then $A = 4\pi r^2 = 4\pi(7)^2 = 4\pi(49) = 196\pi \approx 615.75 \text{ in}^2$.

Lesson 1.7 Practice Set

1. Step 1: Understand the problem.
Step 2: Devise a plan – Translate. Come up with a way to solve the problem. Set up an equation, draw a diagram, make a chart or construct a table as a start to begin your problem-solving plan.
Step 3: Carry out the plan – Solve.
Step 4: Check and Interpret: Check to see if you have used all your information. Then look to see if the answer makes sense.
2.
 - Drawing a diagram.
 - Making a table.
 - Looking for a pattern.
 - Using guess and check.
 - Working backwards.
 - Using a formula.
 - Reading and making graphs.
 - Writing equations.
 - Using linear models.
 - Using dimensional analysis.
 - Using the right type of function for the situation.
3. There are many possible answers. Drawing a diagram and looking for patterns are good strategies for most problems. Also, making a table and drawing a graph are often used together. The “writing an equation” strategy is the one you will work with the most frequently in your study of algebra. These combinations work well together because the pairs use the strengths of those strategies, while lessening the weaknesses of each.
4. **[Note: this item needs to refer to Example 2.]**
36 hours to harvest
How many ears per hour will they harvest?
The field has 660 rows with 300 ears per row, which is $660(300) = 198,000$ ears to harvest.
Since it will take them 36 hours to harvest, the number of ears per hour =
$$\frac{\text{number of ears}}{\text{number of hours}} = \frac{198,000}{36} = 5,500 \text{ ears per hour.}$$
5. It is difficult to create a diagram for an algebraic scenario.
6. To check a solution, substitute the possible solution into the original equation and simplify to see if the solution creates a true statement. The purpose is to make sure the solution you found makes sense.

7. Let w = the number of women and m = the number of men. Then $w + m = 12$. Since there were 4 more women than men, we can write $m = w - 4$. We can substitute into the original equation to get
- $$w + (w - 4) = 12$$
- $$2w - 4 = 12$$
- $$2w = 16$$
- $$w = 8$$
- There are 8 women on the jury.
8. The rope is 14 feet. Let l_1 = the length of the shorter piece and l_2 = length of the longer piece. Then we can write $l_1 + l_2 = 14$. We also know that the longer piece, l_2 , is $l_1 + 2.25$
- So, $l_1 + l_2 = 14$ becomes
- $$l_1 + (l_1 + 2.25) = 14$$
- $$2(l_1) + 2.25 = 14$$
- $$2(l_1) = 11.75$$
- $$l_1 = 5.875 \text{ feet}$$
- By substituting this value into the original equation, we get
- $$l_1 + l_2 = 14$$
- $$5.875 + l_2 = 14$$
- $$l_2 = 8.125$$
9. The total price = the purchase price + amount of sales tax
The sales percent needs to be converted to a decimal, so 7.75% becomes 0.0775.
Then the total price can be calculated by the purchase price times 1.0775.
Let c = the total price
 $c = 35(1.0775) = \$37.71$
10. Let x = the original salary. We know that the new salary = 100% of the original salary + 5% more of the original salary, so 105% of the original salary = new salary.
- $$\frac{1.05x}{1.05} = \frac{45,000}{1.05}$$
- $$x = 42857.14$$
- The original salary was \$42,857.14.
11. We can find the area of the two rooms. Let r_1 = area of the larger room and r_2 = area of the smaller room
Then $r_1 = 14(18) = 252$ sq. feet and $r_2 = 9(10) = 90$ sq. feet.
- The ratio of cost per sq foot = $\frac{250}{252} \approx 0.99$. It costs approximately \$0.99/sq foot.
- To find the cost for the other room, we multiply: $90(0.99) = 89.10$. It will cost approximately \$89.10 to carpet the smaller room.

12. Let c = the final cost of the purse.
 We know the discount is for 15%, so the employee is paying $100\% - 15\% = 85\%$ of the original price.
 The final cost can be found by multiplying the original cost (\$65) by the discount percent written as a decimal (0.85), then subtracting the \$10 coupon.
 So $c = 65(0.85) - 10 = 55.25 - 10 = \45.25 . The final purchase price is \$45.25.
13. Let p = the total price. $p = 250 + 20(25) = 250 + 500 = \750 .
 The total price for the dance is \$750.
14. The total is \$24.00. Let r = the number of rides. So, $24 = 12 + 1.5r$.

$$\begin{array}{r} 24 = 12 + 1.5r \\ -12 \quad -12 \\ \hline 12 = 1.5r \\ 1.5 \quad 1.5 \\ \hline r = 8 \end{array}$$
 The number of rides Rena rode is 8.
15. Let m = the money earned on Saturday
 Then $m = 2.92(22) + 3.50(26) + 4.5(15) = 64.24 + 91.00 + 67.50 = 222.74$
 The ice cream shop earned \$222.74 on Saturday.
16. Let x = the size of the smallest angle. Then we know that $x + 2x + 3x = 180$. So,

$$\begin{array}{r} 6x = 180 \\ 6 \quad 6 \\ \hline x = 30^\circ \end{array}$$
17. *It takes Lily 45 minutes to bathe and groom a dog. How many dogs can she groom in an 9-hour day?*
 The variable should represent the number of dogs. Let d = the number of dogs.
18. *Fourteen less than twice a number is greater than or equal to 16.*
 $2x - 14 \geq 16$
19. The pattern is to multiply every x by 4 to get the corresponding y value. See the table below.

x	$y = 4x$	y
-2	$4(-2) = -8$	-8
-1	$4(-1) = -4$	-4
0	$4(0) = 0$	0
1	$4(1) = 4$	4

20. $3(4) - 11 > -3$

$12 - 11 > -3$

$1 > -3$ ✓

21. domain = [1991, 2005] OR $1991 \leq \text{year} \leq 2005$

range = [22, 36.5] OR $22 \leq \text{percentage} \leq 36.5$

Lesson 1.8 Practice Set

1. The base value is 10 minutes/day. Then, Josie adds 2 minutes/week, so if we let w = the number of weeks, we can calculate the minutes for any number of weeks.

$$10 + 2w \text{ when } w = 6$$

$$10 + 2(6) = 10 + 12 = 22 \text{ minutes in week six}$$

2. Let n = the number of nickels and d = the number of dimes.
We know that $n + d = 40$. We also know that $0.05n + 0.10d = 2.25$.
We can solve the first equation for n : $n = 40 - d$.

Next, substitute that value ($40 - d$) into the second equation for n .

$$0.05n + 0.10d = 2.25 \text{ becomes } 0.05(40 - d) + 0.10d = 2.25$$

Now we can solve for d .

$$0.05(40 - d) + 0.10d = 2.25$$

$$2 - 0.05d + 0.10d = 2.25$$

$$2 + 0.05d = 2.25$$

$$\begin{array}{r} -2 \\ \hline \end{array} \quad \begin{array}{r} -2 \\ \hline \end{array}$$

$$\frac{0.05d}{0.05} = \frac{0.25}{0.05}$$

$$d = 5$$

Now, since there are 5 dimes, we can find the number of nickels by substituting that value into either of equation.

$$n + 5 = 40$$

$$n = 35$$

There are 35 nickels and 5 dimes.

3. The first 3 figures have the first three odd whole numbers: 1, 3, 5... If we continue that concept, the 12th odd whole number will be 1, 3, 5, 7, 9, 11, 13, 15, 17, 19, 21, 23.
The 12th figure will have 23 squares in it.
To calculate this algebraically, we can find the n th odd number by using this formula: $2n - 1$ where n is the number of the figure. Therefore the 12th figure will have $2(12) - 1 = 24 - 1 = 23$ squares.

4. He is reducing the number of cups by 3 cups per week. Therefore, if w = the number of cups, then we can determine how many cups he is drinking by the expression $24 - 3w$. Since we want to know when he will be at 6 cups, we need to solve for w .

$$24 - 3w = 6$$

$$\begin{array}{r} -24 \\ \hline \end{array} \quad \begin{array}{r} -24 \\ \hline \end{array}$$

$$\frac{-3w}{-3} = \frac{-18}{-3}$$

$$w = 6$$

$$w = 6$$

It will take 6 weeks for Oswald to reduce the number of coffee cups to 6.

5. total fine = the number of days x the amount per day = $5(0.10) = \$0.50$
6. We will use the formula $d = rt$ (distance = rate x time). The formula for the car 1 will be $d_1 = r_1t_1$ and the formula for the car 2 will be $d_2 = r_2t_2$.
 Since we are determining that one car is catching up to the other car, we can say that $d_1 = d_2$.
 Because of that, we also know that $r_1t_1 = r_2t_2$.
 We know that $r_1 = 75$ and $r_2 = 55$. Finally, if we let the time of the car 1 to be t_1 , then we know that $t_2 = t_1 + 2$ (Car 2 is traveling 2 hours more).
 By substitution, $75t_1 = 55(t_1 + 2)$. We can solve for the time of the car 1 (the amount of time it will take to catch car 2).
 $75t_1 = 55(t_1 + 2)$
 $75t_1 = 55t_1 + 110$
 $20t_1 = 110$
 $t_1 = 5.5$
 It will take the car 1 5.5 hours to catch car 2.
7. This item will be very similar to item 6. We will again use $d_1 = r_1t_1$ for Grace and the formula for the Dan will be $d_2 = r_2t_2$. Again, since we are determining that Dan is catching up to the Grace, we can say that $d_1 = d_2$.
 Because of that, we also know that $r_1t_1 = r_2t_2$.
 For Grace, $r_1 = 12$ and for Dan, $r_2 = 15$. Dan is traveling for 1 hour less than Grace, so $t_2 = t_1 - 1$
 Using substitution, $12t_1 = 15(t_1 - 1)$.
 Solve for t_1 .
 $12t_1 = 15(t_1 - 1)$
 $12t_1 = 15t_1 - 15$
 $-12t_1 \quad -12t_1$
 $0 = 3t_1 - 15$
 $+15 \quad +15$
 $\frac{15}{3} = \frac{3t_1}{3}$
 $5 = t_1$
 Grace is traveling for 5 hours; therefore, Dan is traveling $5 - 1 = 4$ hours.
8. The largest possible area can be found using a circle. So, we need to find the area of a circle with a circumference of 24 feet. To do this, we need to find the radius of the circle.
 The formula for the circumference of a circle is $C = 2\pi r$ where r is the radius.
 So, $24 = 2\pi r$
 $r = \frac{24}{2\pi} \approx 3.82$ feet
 The formula for finding the area of a circle is $A = \pi r^2$.
 So $A = \pi r^2 \approx \pi(3.82)^2 \approx 45.84$ square feet.

9. This is a function since all of the values in the domain map to exactly one item in the range.

10.

j	Work Shown	m
0	$78(0) = 0$	0
1	$78(1) = 78$	78
2	$78(2) = 156$	156
3	$78(3) = 234$	234
4	$78(4) = 312$	312
n	$78(n) = 78n$	$78n$

11.

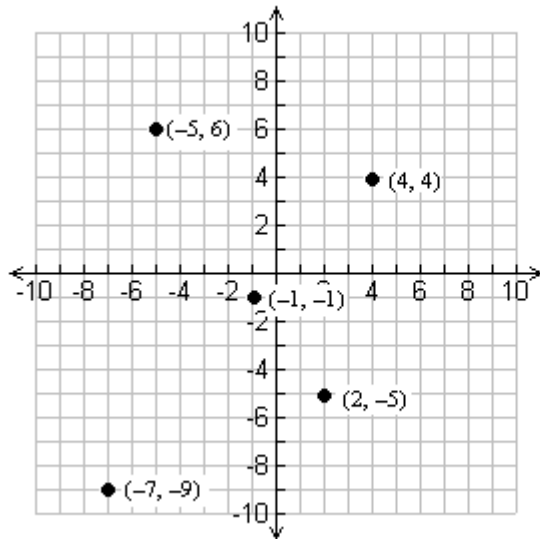

12. $-4(4z - x + 5)$ when $x = -10$ and $z = -8$
 $-4(4(-8) - (-10) + 5) = -4(-32 + 10 + 5) = -4(-17) = 68$

13. $A = \pi r^2 = \pi(6)^2 = 36\pi \approx 113.10 \text{ mm}^2$

14. Louie spent $9(1.19) = \$10.71$

15. $16 \times \frac{1}{8}c = \frac{16}{8}c = 2c$

Lesson 1.9 Chapter Review

1. domain – The set of all possible input values for the independent variable (p. 21)
2. range – The values resulting from the substitution of the domain (p. 21)
3. solution – The **solution** to an equation or inequality is the value (or multiple values) that make the equation or inequality true. (p. 15)
4. evaluate – To **evaluate** means to follow the verbs in the math sentence. **Evaluate** can also be called simplify or answer. (p. 2)
5. substitute – To **substitute** means to replace the variable in the sentence with a value. (p. 2)
6. operation – A math verb is called an **operation**. Operations can be something you have used before, such as addition, multiplication, subtraction or division or be more complex like an exponent or square root (p. 1 – 2)
7. variable – A variable is a symbol, usually an English letter, written to replace an unknown or changing quantity. (p. 2)
8. algebraic expression – An **algebraic expression** is a mathematical phrase combining numbers and/or variables using mathematical operations. (p. 11)
9. equation – When an algebraic expression is set equal to another value, variable, or expression, a new mathematical sentence is created. (p. 14)
10. algebraic inequality – An **algebraic inequality** is a mathematical sentence connecting an expression to a value, variable, or another expression with an inequality sign. (p. 16)
11. function – A **function** is a relationship between two variables such that the input value has **ONLY** one output value. (p. 20)
12. independent variable – a table of values can be created by choosing values to represent the **independent variable**. (p. 21)
13. $3y(7 - (z - y))$ when $y = -7$ and $z = 2$
 $3(-7)(7 - (2 - (-7))) = -21(7 - 9) = -21(-2) = 42$
14. $\frac{m + 3n - p}{4}$ when $m = 9$, $n = 7$, and $p = 2$
 $\frac{m + 3n - p}{4} = \frac{9 + 3(7) - 2}{4} = \frac{28}{4} = 7$

15. $|p| - \left(\frac{n}{2}\right)^3$ when $n = 2$ and $p = 3$

$$|3| - \left(\frac{2}{2}\right)^3 = 3 - 1^3 = 3 - 1 = 2$$

16. $|v - 21|$ when $v = -70$

$$|-70 - 21| = |-91| = 91$$

17. let c = the number of candies

18. let t = the number of tomatoes

19. let c = the number of cats

20. let s = the amount of snow

21. let w = the number of water skiers

22. let g = the number of geese

23. let p = the number of people

24. $A = 4\pi r^2 = 4\pi(10)^2 = 4\pi(100) = 400\pi \approx 1,256.64 \text{ in}^2$

25. $A = 4\pi r^2 = 4\pi(2.4)^2 = 4\pi(5.76) = 23.04\pi \approx 72.38 \text{ cm}^2$

26. The diameter is 19 m, so the radius is 9.5 m.

$$A = 4\pi r^2 = 4\pi(9.5)^2 = 4\pi(90.25) = 361\pi \approx 1134.11 \text{ m}^2$$

27. $A = 4\pi r^2 = 4\pi(0.98)^2 = 4\pi(0.9604) = 3.8416\pi \approx 12.07 \text{ mm}^2$

28. The diameter is 5.5 inches, so the radius is 2.75 inches.

$$A = 4\pi r^2 = 4\pi(2.75)^2 = 4\pi(7.5625) = 30.25\pi \approx 95.03 \text{ in}^2$$

29. $1 + (2 \cdot 3) + 4 = 15$ Parentheses are not needed, since the order of operations require one to multiply before adding.

30. $5 \cdot (3 - 2 + 6) = 35$

31. $(3 + 1) \cdot (7 - 2^2) \cdot (9 - 7) = 24$

32. $(4 + 6) \cdot 2 \cdot (5 - 3) = 40$

33. $(3^2 + 2) \cdot (7 - 4) = 33$

34. Thirty-seven more than a number is 612 $\rightarrow x + 37 = 612$
34. The product of u and -7 equals 343 $\rightarrow -7u = 343$
36. The quotient of k and 18 $\rightarrow k \div 18$ OR $\frac{k}{18}$
37. Eleven less than a number is 43 $\rightarrow x - 11 = 43$
38. A number divided by -9 is -78 $\rightarrow a \div -9 = -78$ OR $\frac{a}{-9} = -78$
39. The difference between 8 and h is 25 $\rightarrow 8 - h = 25$
40. The product of 8 -2 , and r $\rightarrow (8 - 2)r$
41. Four plus m is less than or equal to 19 $\rightarrow 4 + m \leq 19$
42. Six is less than c $\rightarrow c - 6$
43. Forty-two less than y is greater than 57 $\rightarrow y - 42 > 57$
44. Let m = the number of movies watched and let t = the total time
45. A half-dozen is 6. Let d = then number of donuts. Then $d = 168(6) = 1,008$
donuts
46. Let m = the number of mowing jobs and l = the number of landscaping jobs.
Then $10m + 35l \geq 8600$.
47. $t = 0.9, 54 \leq 7(9t + 5)$
 $54 \leq 7(9(0.9) + 5)$
 $54 \leq 7(8.1 + 5)$
 $54 \leq 7(8.6)$
 $54 \leq 60.2$ ✓
48. $f = 2; f + 2 + 5f = 14$
 $2 + 2 + 5(2) = 14$
 $4 + 10 = 14$
 $14 = 14$ ✓

49. $p = -6; 4p - 5p \leq 5$

$$4(-6) - 5(-6) \leq 5$$

$$-24 - (-30) \leq 5$$

$$-24 + 30 \leq 5$$

$$6 \leq 5 \quad \mathbf{X}$$

50. Let m = the number of text messages and c = the cost. Then $c = 18 + 0.05m$.

51. Let m = the number of months and c = the cost. Then $c = 14.99m$.

52. domain - $-\infty < x < \infty$ (All real numbers)

range - $0 \leq y < \infty$

53. Let v = the number of vending machines. Then

$$\frac{128v}{128} = \frac{5100}{128}$$

$$v = 39.84$$

Henry needs to install 40 machines to break even.

54. Yes, this is a function since it passes the vertical line test.

55. Let p = the number of games the Pelicans won and r = the number of games the Raccoons won. Then we know that $p + r = 38$. Since $r = 13$, then we can substitute that value. Therefore, $p + 13 = 38$ and $p = 38 - 13 = 25$. The Pelicans won 25 games.

56. Let e = the number of people in Elmwood and m = the number of people in Maplewood. Then we can write $e + 250 = m$ and $e = 900$. So, by substitution, $900 + 250 = 1150 = m$.

57. Let x = the number of minutes in the Bonus Plan and y = the number of minutes in the Basic Plan. Then we know that $x = 4y$. We can substitute since $x = 1200$ to get

$$\frac{1200}{4} = \frac{4y}{4}$$

$$300 = y$$

The Basic Plan gives one 300 minutes.

58. Let t = the total number of minutes exercised. Then $t = 24(7) = 168$ hours.

59. Let t = the cost of tickets at the mall theater. Then we know that the tickets at the downtown theater is

$$t - 1.50 = 8$$

$$+1.50 \quad + 1.50$$

$$t = 9.50$$

The tickets at the mall theater costs \$9.50.

60. Let f = the number of feet for every-day tape. Then $f - 75 = 225$. So $f = 225 - 75 = 150$ feet.

61. Let s = the number of strikes Junior got. Then

$$\underline{28} = \underline{3.5s}.$$

$$3.5 \quad 3.5$$

$$s = 8.$$

Junior got 8 strikes.

Lesson 1.10 Chapter Test

1. Let p = the price on Tuesday. Then $p + 59 = 255$. Solving for $p = 255 - 59 = 196$. The stock price on Tuesday was 196.
2. Let k = the height of the oak and m = the height of the maple. Then $k = m + 40$.
- 3.

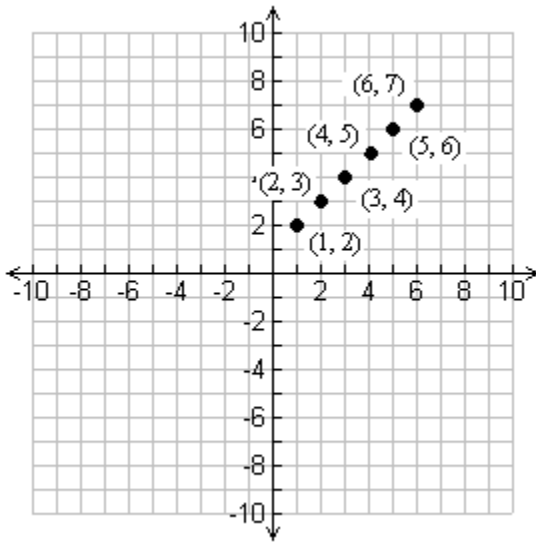

4. domain $-5 \leq x \leq 9$; range $8 \leq y \leq 25$
5. No, this is not a function because the 3 in the domain is mapped to two different values in the range.
6. $(5bc) - a$ when $a = 2$, $b = 3$, $c = 4$
 $5(3)(4) - 2 = 58$
7. $3[36 \div (3 + 6)] = 3(36 \div 9) = 3(4) = 12$
8. Let p = the price of the pizza
 $\frac{1}{8}p = 1.09$
 $p = 1.09(8) = 8.72$
The pizza costs \$8.72.

9. Let g = the number of girls. Then the number of boys is $g - 17$. We know that the number of girls + the number of boys = 561. So,

$$g + (g - 17) = 561$$

$$2g - 17 = 561$$

$$2g = 578$$

$$g = 289$$

There are 289 girls.

10. The quotient of 8 and y is 48.

11. Use $b = 16h$, where b = the number of boxes and h = the number of hours

Hours	0	2	4	5	8	10	12	14
Boxes	0	32	64	80	128	160	192	234

12. We need to know “18 is $\frac{1}{8}$ of what number?” If we translate, we get the following equation:

$$18 = \frac{1}{8}x$$

To solve for x , we will multiply both sides of the equation by $\frac{8}{1}$.

$$\left(\frac{8}{1}\right)18 = \frac{1}{8}x\left(\frac{8}{1}\right)$$

$$x = 144$$

Therefore, there were 144 students in the class.

13. $\{(2, 3), (4, 5), (6, 7), (-2, -3), (-3, -4)\}$
 domain – $\{-2, -3, 2, 4, 6\}$ range – $\{-3, -4, 3, 5, 7\}$

14. The rule is $y = 60x$. For every x , multiply by 60 to get y .

15. Determine if $y = 6$ is a solution of $\frac{6-y}{y} > -8$.

$$\frac{6-6}{6} > -8$$

$$\frac{0}{6} > -8$$

$$0 > -8$$

Therefore, $y = 6$ is a solution of the inequality.

Chapter 2

Lesson 2.1

1. Absolute value represents the distance from zero when graphed on a number line.
2. proper fractions, improper fractions, equivalent
3. There are many possible answers. Some examples are 1.3, 0.55, and $\frac{12}{37}$.
4. Rational numbers can be written as a ratio of two integers, where irrational numbers cannot.
5. Since the tic marks are evenly spaced, we can determine that each mark represents 3 units because there are 7 marks from 0 to 21 and $21 \div 7 = 3$. Therefore, $a: -3, b: 3, c: 9, d: 12, e: 15$
6. There are 3 sections and one is shaded: $\frac{1}{3}$.
7. There are 12 sections and 7 are shaded: $\frac{7}{9}$.
8. There are 70 squares and 44 squares shaded: $\frac{44}{70} = \frac{22}{35}$.
9. If the numerators are the same, the larger the denominator, the smaller the fraction. So, $\frac{1}{4}, \frac{1}{3}, \frac{1}{2}$.

10. The fractions are in reverse order. Since they all have different denominators and numerators, we must get a common denominator:

$$10(11)(12) = 1320$$

$$\frac{13 \times 132}{10 \times 132} = \frac{1,716}{1,320}$$

$$\frac{12 \times 120}{11 \times 120} = \frac{1,440}{1,320}$$

$$\frac{11 \times 110}{12 \times 110} = \frac{1,210}{1,320}$$

Now we know the correct order by comparing the numerators: $\frac{11}{12}, \frac{12}{11}, \frac{13}{10}$.

11. We need to find a common denominator between 60, 80, and 100.

$$\frac{39}{60} = \frac{39(80)}{4800} = \frac{3120}{4800}$$

$$\frac{49}{80} = \frac{49(60)}{4800} = \frac{2940}{4800}$$

$$\frac{59}{100} = \frac{59(48)}{4800} = \frac{2832}{4800}$$

By comparing the denominators, we find the order should be $\frac{59}{100}, \frac{49}{80}, \frac{39}{60}$.

12. We must first get a common denominator.

$$11(13)(19) = 2717$$

$$\frac{7 \times 247}{11 \times 247} = \frac{1,729}{2,717}$$

$$\frac{8 \times 209}{13 \times 209} = \frac{1,672}{2,717}$$

$$\frac{12 \times 143}{19 \times 143} = \frac{1,716}{2,717}$$

We can now determine the order of $\frac{8}{13}, \frac{12}{19}, \frac{7}{11}$.

13. $\frac{22 \div 22}{44 \div 22} = \frac{1}{2}$

14. $\frac{9 \div 9}{27 \div 9} = \frac{1}{3}$

15. $\frac{12 \div 6}{18 \div 6} = \frac{2}{3}$

16. $\frac{315 \div 5}{420 \div 5} = \frac{63 \div 21}{84 \div 21} = \frac{3}{4}$

17. Since 19 is a prime number, this fraction can not be reduced.

18. $\frac{99 \div 11}{11 \div 11} = \frac{9}{1} = 9$

19. The opposite of 1.001 is -1.001 .

20. The opposite of -9.345 is 9.345 .

21. The opposite of $(16 - 45) = -(16 - 45)$. Simplified, the answer is $-(-29) = 29$.

22. The opposite of $(5 - 11) = -(5 - 11)$. Simplified, the answer is $-(-6) = 6$.

23. The opposite of $(x + y) = -(x + y)$ or $-x - y$.
24. The opposite of $(x - y) = -(x - y) = -x + y$.
25. $|-98.4| = 98.4$
26. $|123.567| = 123.567$
27. $-|16 - 98| = -|-82| = -(82) = -82$
28. $11 - |-4| = 11 - 4 = 7$
29. $|4 - 9| - |-5| = |-5| - 5 = 5 - 5 = 0$
30. $|-5 - 11| = |-16| = 16$
31. $7 - |22 - 15 - 19| = 7 - |-12| = 7 - 12 = -5$
32. $-|-7| = -7$
33. $|-2 - 88| - |88 + 2| = |-90| - |90| = 90 - 90 = 0$
34. $|-5 - 99| + |-16 - 7| = |-104| - |9| = 104 - 9 = 95$
35. To compare the numbers, compare the first two digits. Since $8 > 7$, then $8 > 7.99999$.
36. First, convert $\frac{-17}{4}$ to a decimal. $\frac{-17}{4} = -4.25$.
Then we can see that $-4.5 = \frac{-17}{4}$.
37. $65 > -1$
38. 10 units left of zero is -10 and 9 units right of zero is 9. So, $-10 < 9$.
39. After one jump the frog will land on either $7 + 2 = 9$, or $7 - 2 = 5$. After 5 jumps, the frog could end up at $7 - 5(2) = 7 - 10 = -3$, $7 + 5(2) = 7 + 10 = 17$, or any integer in between. Written differently, $-3 < x < 17$ where x = the location of the frog.
40. All real numbers will have an additive identity except 0 because it does not have an opposite.
41. $\frac{5}{6}d + 7a^2 = \frac{5}{6}(24) + 7(-1)^2 = 20 + 7 = 27$

42. Let l = the length of the rectangle and w = the width of the rectangle. Then we have $2l + 2w = 22$. Also we know that $w = l - 1$. By substitution,

$$2l + 2(l - 1) = 22$$

$$2l + 2l - 2 = 22$$

$$4l - 2 = 22$$

$$\frac{4l}{4} = \frac{24}{4}$$

$$l = 6$$

$$l = 6$$

That means that $w = 6 - 1 = 5$. The length is 6 inches, and the width is 5 inches.

43. $4(2) + 7 \leq 15$

$$8 + 7 \leq 15$$

$$15 \leq 15 \checkmark$$

44.
$$\frac{(7+3) \div 2 \times 3^2 - 5}{(58-8)} = \frac{10 \div 2 \times 9 - 5}{50} = \frac{45 - 5}{50} = \frac{40}{50} = \frac{4}{5}$$

Lesson 2.2

1. $3 + 3 + 1 - (-1) = 7 + 1 = 8$

2. $0 - 2 + 7 + 1 = 6$

3. $\frac{3}{7} + \frac{2}{7} = \frac{3+2}{7} = \frac{5}{7}$

4. $\frac{3}{10} + \frac{1}{5} = \frac{3+1(2)}{10} = \frac{5}{10} = \frac{1}{2}$

5. $\frac{5}{16} + \frac{5}{12} = \frac{5(3)+5(4)}{48} = \frac{15+20}{48} = \frac{35}{48}$

6. $\frac{3}{8} + \frac{9}{16} = \frac{3(2)+9}{16} = \frac{15}{16}$

7. $\frac{8}{25} + \frac{7}{10} = \frac{8(2)+7}{50} = \frac{23}{50}$

8. $\frac{1}{6} + \frac{1}{4} = \frac{1(2)+1(3)}{12} = \frac{5}{12}$

9. $\frac{7}{15} + \frac{2}{9} = \frac{7(3)+2(5)}{45} = \frac{21+10}{45} = \frac{31}{45}$

10. $\frac{5}{19} + \frac{2}{27} = \frac{5(27)+2(19)}{513} = \frac{135+38}{513} = \frac{173}{513}$

11. $-2.6 + 11.19 = 8.59$

12. $-8 + 13 = 5$

13. $-7.1 + (-5.63) = -7.1 - 5.63 = -12.73$

14. $9.99 + (-0.01) = 9.99 - 0.01 = 9.98$

15. $4\frac{7}{8} + 1\frac{1}{2} = \frac{39}{8} + \frac{3}{2} = \frac{39+3(4)}{8} = \frac{39+12}{8} = \frac{51}{8}$

16. $-3\frac{1}{3} + \left(-2\frac{3}{4}\right) = \frac{-10}{3} + \frac{-11}{4} = \frac{-10(4)-11(3)}{12} = \frac{-40-33}{12} = \frac{-73}{12}$

17. Order refers to the commutative property, so the commutative property of addition.
18. This is the associative property of addition.
19. This is a variation of the additive identity property.
20. This is the additive identity property.
21. Let c = the total cost. Nadia contributes is $\frac{1}{2}c$, Ian contributes $\frac{1}{3}c$, and Peter contributes $\frac{1}{4}c$. In total, they contribute
- $$\frac{1}{2} + \frac{1}{3} + \frac{1}{4} = \frac{1(6) + 1(4) + 1(3)}{12} = \frac{6 + 4 + 3}{12} = \frac{13}{12}$$
- Therefore, the amount of tax is $\frac{13}{12} - 1 = \frac{13}{12} - \frac{12}{12} = \frac{1}{12}$ the total cost.
22. $-160 + 8 = -152$ feet
23. $-8 + 25 = 17$ degrees
24. $9.1 + 5.8 = 14.9$
25. $5.8 + (-5.8) = 0$
26. $-5.8 + 4.12 = -1.68$
27. $-23.14 + (-5.8) = -28.94$
28. $7.86 + (-5.8) = 2.06$
29. $-5.8 + 3.5 = -2.3$
30. $-5.8 + 5.8 = 0$
31. The opposite of -72 is 72 .
32. $|16 - 29 + 78 - 114| = |-49| = 49$
33. domain = $\{1, 2, 3, 4\}$ and range = $\{-3, -1, 0, 6\}$
34. Mass = $20.1(\text{Volume})$

Lesson 2.3

1. $9 - 14 = -5$

2. $2 - 7 = -5$

3. $21 - 8 = 13$

4. $8 - (-14) = 8 + 14 = 22$

5. $-11 - (-50) = -11 + 50 = 39$

6. $\frac{5}{12} - \frac{9}{18} = \frac{5}{12} - \frac{1}{2} = \frac{5-1(6)}{12} = \frac{5-6}{12} = \frac{-1}{12}$

7. $5.4 - 1.01 = 4.39$

8. $\frac{2}{3} - \frac{1}{4} = \frac{2(4)-1(3)}{12} = \frac{8-3}{12} = \frac{5}{12}$

9. $\frac{3}{4} - \frac{1}{3} = \frac{3(3)-1(4)}{12} = \frac{9-4}{12} = \frac{5}{12}$

10. $\frac{1}{4} - \left(-\frac{2}{3}\right) = \frac{1}{4} + \frac{2}{3} = \frac{1(3)+2(4)}{12} = \frac{3+8}{12} = \frac{11}{12}$

11. $\frac{15}{11} - \frac{9}{7} = \frac{15(7)-9(11)}{77} = \frac{105-99}{77} = \frac{6}{77}$

12. $\frac{2}{13} - \frac{1}{11} = \frac{2(11)-1(13)}{143} = \frac{22-13}{143} = \frac{9}{143}$

13. $-\frac{7}{8} - \left(-\frac{8}{3}\right) = -\frac{7}{8} + \frac{8}{3} = \frac{-7(3)+8(8)}{24} = \frac{-21+64}{24} = \frac{43}{24}$

14. $\frac{7}{27} - \frac{9}{39} = \frac{7(39)-9(27)}{1053} = \frac{273-243}{1053} = \frac{30}{1053} = \frac{10}{351}$

15. $\frac{6}{11} - \frac{3}{22} = \frac{6(2)-3}{22} = \frac{12-3}{22} = \frac{9}{22}$

16. $-3.1 - 21.49 = -24.59$

17. $\frac{13}{64} - \frac{7}{40} = \frac{13(5)-7(8)}{320} = \frac{80-56}{320} = \frac{24}{320} = \frac{3}{40}$

$$18. \frac{11}{70} - \frac{11}{30} = \frac{11(3) - 11(7)}{210} = \frac{33 - 77}{210} = \frac{-44}{210} = -\frac{22}{105}$$

$$19. -68 - (-22) = -68 + 22 = -46$$

$$20. \frac{1}{3} - \frac{1}{2} = \frac{1(2) - 1(3)}{6} = \frac{2 - 3}{6} = -\frac{1}{6}$$

$$21. 9 - (-14) = 9 + 14 = 23$$

22. When $x = 3$, $y = 3(3) + 2 = 6 + 2 = 8$. When $x = 7$, $y = 3(7) + 2 = 21 + 2 = 23$. So, the difference is $23 - 8 = 15$.

$$23. \text{ When } x = 1, y = \frac{2}{3}(1) + \frac{1}{2} = \frac{2}{3} + \frac{1}{2} = \frac{2(2) + 1(3)}{6} = \frac{4 + 3}{6} = \frac{7}{6}. \text{ When } x = 7,$$

$$y = \frac{2}{3}(7) + \frac{1}{2} = \frac{14}{3} + \frac{1}{2} = \frac{4(7) + 1(3)}{6} = \frac{28 + 3}{6} = \frac{31}{6}. \text{ So, the difference is}$$

$$\frac{31}{6} - \frac{7}{6} = \frac{24}{6} = 4.$$

24. This statement is false. Consider the example $3 - (-4) = 12$. Twelve is greater than both 3 and -4 .

25. This statement is true. For any number, x , $x - (-x) = x + x = 2x$.

26. The closing price will be $\$4.83 - \$0.97 = \$3.86/\text{share}$.

$$27. (a - b) + c = 2 - (-3) + (-1.5) = 5 - 1.5 = 3.5$$

$$28. |b + c| - a = |-3 + (-1.5)| - 2 = |-4.5| - 2 = 4.5 - 2 = 2.5$$

$$29. a - (b + c) = 2 - (-3 + (-1.5)) = 2 - (-4.5) = 2 + 4.5 = 6.5$$

$$30. |b| + |c| + a = |-3| + |-4.5| + 2 = 3 + 4.5 + 2 = 9.5$$

$$31. 7b + 4a = 7(-3) + 4(2) = -21 + 8 = -13$$

$$32. (c - a) - b = (-1.5 - 2) - (-3) = -3.5 + 3 = -0.5$$

33.

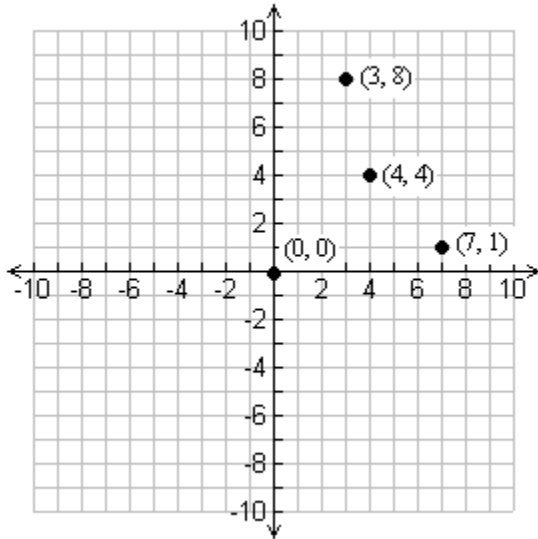

34. When $m = -\frac{2}{3}$, the expression is $\frac{2^3 + -\frac{2}{3}}{4} = \frac{8 - \frac{2}{3}}{4} = \frac{\frac{24-2}{3}}{4} = \frac{\frac{22}{3}}{4} = \frac{22}{3} \left(\frac{4}{1} \right) = \frac{88}{3}$.

35. Let r = the amount of money Ricky has, s = the amount of money Stacy has, and a = the amount of money Aaron has. Then we know that $r + s + a = 62$. Since we know Ricky, r , has \$12 more than Stacy, s , then we can write $r = s + 12$. We also know that Stacy, s , has \$5 fewer than Aaron, a , so we can write $a = s + 5$. By substitution, $r + s + a = 62$ becomes $(s + 12) + s + (s + 5) = 62$. Simplifying gives $3s + 17 = 62$.

36. $\frac{1}{3} + \frac{7}{5} = \frac{1(5) + 7(3)}{15} = \frac{5 + 21}{15} = \frac{26}{15}$

37. $\frac{21}{4} - \frac{2}{3} = \frac{21(3) - 2(4)}{12} = \frac{63 - 8}{12} = \frac{55}{12}$

Lesson 2.4

$$1. \frac{1}{2} \cdot \frac{3}{4} = \frac{1(3)}{2(4)} = \frac{3}{8}$$

$$2. -7.85 - 2.3 = -10.15$$

$$3. \frac{2}{5} \cdot \frac{5}{9} = \frac{2(5)}{5(9)} = \frac{2}{9}$$

$$4. \frac{1}{3} \cdot \frac{2}{7} \cdot \frac{2}{5} = \frac{1(2)(2)}{3(7)(5)} = \frac{4}{105}$$

$$5. 4.5 \cdot -3 = -13.5$$

$$6. \frac{1}{2} \cdot \frac{2}{3} \cdot \frac{3}{4} \cdot \frac{4}{5} = \frac{1(2)(3)(4)}{2(3)(4)(5)} = \frac{1}{5}$$

$$7. \frac{5}{12} \times \frac{9}{10} = \frac{5(9)}{12(10)} = \frac{45}{120} = \frac{3}{8}$$

$$8. \text{Since anything times 0 is 0, } \frac{27}{5} \cdot 0 = 0$$

$$9. \frac{2}{3} \times \frac{1}{4} = \frac{2(1)}{3(4)} = \frac{2}{12} = \frac{1}{6}$$

$$10. -11.1(4.1) = -45.51$$

$$11. \frac{3}{4} \times \frac{1}{3} = \frac{1}{4}$$

$$12. \frac{15}{11} \times \frac{9}{7} = \frac{15(9)}{11(7)} = \frac{135}{77}$$

$$13. \frac{2}{7} \cdot -3.5 = \frac{2(-3.5)}{7} = \frac{-7}{7} = -1$$

$$14. \frac{1}{13} \times \frac{1}{11} = \frac{1}{143}$$

$$15. \frac{7}{27} \times \frac{9}{14} = \frac{7(9)}{27(14)} = \frac{1}{6}$$

$$16. \left(\frac{3}{5}\right)^2 = \frac{3^2}{5^2} = \frac{9}{25}$$

$$17. \frac{1}{11} \times \frac{22}{21} \times \frac{17}{10} = \frac{1(22)(17)}{11(21)(10)} = \frac{17}{1155}$$

$$18. 5.75 \cdot 0 = 0$$

$$19. 79.5(-1) = -79.5$$

$$20. \pi(-1) = -\pi$$

$$21. (x + 1)(-1) = -(x + 1)$$

$$22. |x|(-1) = -|x|$$

$$23. 25(-1) = -25$$

$$24. -105(-1) = 105$$

$$25. x^2(-1) = -x^2$$

$$26. (-1)(3 + x) = -1(3 + x) = -3 - x$$

$$27. (-1)(3 - x) = -1(3 - x) = -3 + x$$

28. Since $3 + 5 = 8$, this is the distributive property because $8(7) = 3(7) + 5(7)$.

29. Since there is only one pile, this is the multiplicative identity, or identity of multiplication because $10(1) = 10$.

30. This is the commutative property of addition since $3(5) = 5(3)$.

31. To compare these numbers, we first need to get a common denominator. The common denominator is 27, so the first fraction, $\frac{16}{27}$, will stay the same. We need to convert the second fraction.

$$\frac{2 \times 9}{3 \times 9} = \frac{18}{27}. \text{ Since } 16 < 18, \frac{16}{27} < \frac{18}{27} \text{ therefore } \frac{16}{27} < \frac{2}{3}.$$

32. rational numbers – numbers that can be written as a ratio of two integers.

33. A proper fraction is a fraction where the absolute value of the numerator is smaller than the absolute value of the denominator, such as $\frac{1}{2}$, $\frac{112}{245}$, or $-\frac{18}{93}$. An improper fraction is where the absolute value of the numerator is larger than the absolute value of the denominator, like $\frac{-8}{3}$, $\frac{11}{2}$, or $\frac{213}{5}$.

35. This property is the additive inverse property.

$$36. 11\frac{2}{9} + \frac{7}{8} = \frac{101}{9} + \frac{7}{8} = \frac{101(8) + 7(9)}{72} = \frac{808 + 63}{72} = \frac{871}{72}$$

Quick Quiz

1. To order these, we could find a common denominator for all of the fractions, but an easier method would be to convert all of the fractions to decimals and compare them.

$$\frac{5}{6} = 0.83333, \frac{23}{26} = 0.8846, \frac{31}{32} = 0.9393, \frac{3}{14} = 0.2143$$

Now, the order, from least to greatest is $\frac{3}{14}, \frac{5}{6}, \frac{23}{26}, \frac{31}{32}$.

$$2. \frac{5}{9} \times \frac{27}{4} = \frac{15}{4}$$

$$3. |-5 + 11| - |9 - 37| = |6| - |-28| = 6 - 28 = -22$$

$$4. \frac{21}{5} + \frac{7}{8} = \frac{21(8) + 7(5)}{40} = \frac{168 + 35}{40} = \frac{203}{40}$$

Lesson 2.5

1. $(x + 4) - 2(x + 5) = x + 4 - 2x - 10 = -x - 6$
2. $\frac{1}{2}(4z + 6) = 2z + 3$
3. $(4 + 5) - (5 + 2) = 9 - 5 - 2 = 2$
4. $(x + 2 + 7) = x + 9$
5. $0.25(6q + 32) = 1.5q + 8$
6. $y(x + 7) = xy + 7y$
7. $-4.2(h - 11) = -4.2h + 46.2$
8. $13x(3y + z) = 39xy + 13xz$
9. $\frac{1}{2}(x - y) - 4 = \frac{1}{2}x - \frac{1}{2}y - 4$
10. $0.6(0.2x + 0.7) = 0.12x + 0.42$
11. $(2 - j)(-6) = -12 + 6j$
12. $(r + 3)(-5) = -5r - 15$
13. $6 + (x - 5) + 7 = 6 + x - 5 + 7 = x + 8$
14. $6 - (x - 5) + 7 = 6 - x + 5 + 7 = -x + 18$
15. $4(m + 7) - 6(4 - m) = 4m + 28 - 24 + 6m = 10m + 4$
16. $-5(y - 11) + 2y = -5y + 55 + 2y = -3y + 55$
17. $\frac{8x+12}{4}$ is the same as $\frac{1}{4}(8x+12) = 2x+3$
18. $\frac{9x+12}{3}$ is the same as $\frac{1}{3}(9x+12) = 3x+4$
19. $\frac{11x+12}{2} = \frac{1}{2}(11x+12) = \frac{11}{2}x+6$

20. $\frac{3y+2}{6} = \frac{1}{6}(3y+2) = \frac{1}{2}y + \frac{1}{3}$

21. $-\frac{6z-2}{3} = -\frac{1}{3}(6z-2) = -2z + \frac{2}{3}$

22. $\frac{7-6p}{3} = \frac{7}{3} - 2p$

23. $\frac{2}{3}n + 16$

24. $2m - 3$

25. $-4x(x) + 2$

26. Let p = the number of poetry books and n = the number of novels. Then the expression is $5(7p + 11n)$ OR $35p + 55n$

27. One could estimate 19.99 to 20. Then $20 - 19.99 = 0.01$. So, $6(19.99) = 6(20) - 6(0.01) = 120 - 0.06 = 119.94$.

28. The student did not distribute the 4 to the second value (10) in the parentheses. The correct answer would be $4(9x + 10) = 36x + 40$.

29. Like item 27, we can round 5998 up to 6000. Then $9(5998) = 9(6000) - 9(2) = 54,000 - 18 = 53,982$

30. a. First, $5 \text{ lbs} = 5(16) = 80 \text{ oz}$. Then he can make $\frac{80}{6} = 13.\bar{3}$, or 13 cookies.

b. Second, using the number of cookies from a., he can put $\frac{60}{13} \approx 4.62$, or about 5 nuts on each cookie.

31. Let x = how much more Jacob needs. Then we have $104 + x \geq 244$.

32. The product of 6 and a number is 4 less than 16.

33. To represent the mixed number, fill in 3 whole rows for the whole number and 3 out of 4 parts of the row for $\frac{3}{4}$.

$$34. \text{ When } x = 3, y = \frac{1}{6}(3) - 4 = \frac{1}{2} - 4 = \frac{1 - 4(2)}{2} = -\frac{7}{2}.$$

$$\text{When } x = 9, y = \frac{1}{6}(9) - 4 = \frac{3}{2} - 4 = \frac{3 - 4(2)}{2} = -\frac{5}{2}.$$

$$\text{So, the change in } y = -\frac{5}{2} - \left(-\frac{7}{2}\right) = -\frac{5}{2} + \frac{7}{2} = \frac{2}{2} = 1.$$

Lesson 2.6

1. inverse – the opposite of something. In relation to operations, it is the operation that undoes another operation.
2. The multiplicative inverse for any number x is $\frac{1}{x}$. Their product is 1. The additive inverse for any number x is $-x$. Their sum is 0.
3. The multiplicative inverse of 100 is $\frac{1}{100}$.
4. The multiplicative inverse of $\frac{2}{8}$ is $\frac{8}{2}$.
5. The multiplicative inverse of $-\frac{19}{21}$ is $-\frac{21}{19}$.
6. The multiplicative inverse of 7 is $\frac{1}{7}$.
7. The multiplicative inverse of $-\frac{z^3}{2xy^2}$ is $-\frac{2xy^2}{z^3}$.
8. The multiplicative inverse of 0 is 0.
9. The multiplicative inverse of $\frac{1}{3}$ is 3.
10. The multiplicative inverse of $\frac{-19}{18}$ is $\frac{-18}{19}$.
11. The multiplicative inverse of $\frac{3xy}{8z}$ is $\frac{8z}{3xy}$.
12. $\frac{5}{2} \div \frac{1}{4} = \frac{5}{2} \left(\frac{4}{1} \right) = \frac{20}{2} = 10$
13. $\frac{1}{2} \div \frac{7}{9} = \frac{1}{2} \left(\frac{9}{7} \right) = \frac{9}{14}$
14. $\frac{5}{11} \div \frac{6}{7} = \frac{5}{11} \left(\frac{7}{6} \right) = \frac{35}{66}$

$$15. \frac{1}{2} \div \frac{1}{2} = \frac{1}{2} \left(\frac{2}{1} \right) = \frac{2}{2} = 1 \text{ (multiplicative inverse)}$$

$$16. -\frac{x}{2} \div \frac{5}{7} = -\frac{x}{2} \left(\frac{7}{5} \right) = -\frac{7x}{10}$$

$$17. \frac{1}{2} \div \frac{x}{4y} = \frac{1}{2} \left(\frac{4y}{x} \right) = \frac{4y}{2x} = \frac{2y}{x}$$

$$18. -\frac{1}{3} \div \left(-\frac{3}{5} \right) = -\frac{1}{3} \left(-\frac{5}{3} \right) = \frac{5}{9}$$

$$19. \frac{7}{2} \div \frac{7}{4} = \frac{7}{2} \left(\frac{4}{7} \right) = \frac{4}{2} = 2$$

$$20. 11 \div \left(-\frac{x}{4} \right) = 11 \left(-\frac{4}{x} \right) = -\frac{44}{x}$$

$$21. \frac{x}{y} = \frac{\frac{3}{8}}{\frac{4}{3}} = \frac{3}{8} \left(\frac{3}{4} \right) = \frac{9}{32}$$

$$22. 4z \div u = 4(10) \div 0.5 = 40 \div 0.5 = 80$$

$$23. \frac{-6}{m} = \frac{-6}{\frac{2}{5}} = -6 \left(\frac{5}{2} \right) = -15$$

24. We can determine if $\frac{\text{painted coverage (sample)}}{\text{amount of paint (sample)}}$ is $<$, $>$ or $=$ 50 sq ft/pint. So with

the values given: $\frac{2(3)}{\frac{1}{8}} = \frac{6}{\frac{1}{8}} = 6(8) = 48$ sq ft. Since $50 > 48$, the coverage in the

sample is less than the stated coverage.

25. To find the amount of time, we can use $d = rt$, or distance = rate (time). Since we need to know how much time, we can solve for time in the equation to get

$$\text{time} = \frac{\text{distance}}{\text{rate}} = \frac{\frac{2}{3}}{\frac{8}{3}} = \frac{2}{3} \left(\frac{3}{8} \right) = \frac{16}{9} \approx 1.78 \text{ hours OR 1 hour and 47 minutes.}$$

26. Newton's 2nd law gives the equation $F = ma$ (force = mass x acceleration). We need to know the mass of the object, so $m = \frac{F}{a}$. Using our values yields

$$m = \frac{\frac{2}{7}}{\frac{3}{10}} = \frac{2}{7} \left(\frac{10}{3} \right) = \frac{20}{21} \text{ kg.}$$

27. The reciprocal must be a number when multiplied by the original gives a product of 1, whereas the opposite of a number will add to the original to give a sum of 0.

28. Zero does not have a reciprocal because dividing by zero is undefined.

29. $199 - (-11) = 199 + 11 = 210$

30. $-2.3 - (-3.1) = -2.3 + 3.1 = 0.8$

31. $|16 - 84| = |-68| = 68$

32. $|\frac{-11}{4}| = \frac{11}{4}$

33. $(4 \div 2 \times 6 + 10 - 5)^2 = (12 + 5)^2 = (17)^2 = 289$

34. $f(21) = \frac{1}{9}(21 - 3) = \frac{1}{9}(18) = \frac{18}{9} = 2$

35. range = all the values represented by the dependent variable (resulting from substituting the values in from the domain.)

Lesson 2.7

1. $\sqrt{25} = 5$

2. $\sqrt{24} = \sqrt{4(6)} = 2\sqrt{6}$

3. $\sqrt{20} = \sqrt{4(5)} = 2\sqrt{5}$

4. $\sqrt{200} = \sqrt{100(2)} = 10\sqrt{2}$

5. $\sqrt{2000} = \sqrt{400(5)} = 20\sqrt{5}$

6. $\sqrt{\frac{1}{4}} = \frac{\sqrt{1}}{\sqrt{4}} = \frac{1}{2}$

7. $\sqrt{\frac{9}{4}} = \frac{\sqrt{9}}{\sqrt{4}} = \frac{3}{2}$

8. $\sqrt{0.16} = \sqrt{0.4(0.4)} = 0.4$

9. $\sqrt{0.1} = \sqrt{0.1}$ (cannot reduce further to an exact value)

10. $\sqrt{0.01} = 0.1$

11. $\sqrt{13} \approx 3.61$

12. $\sqrt{99} \approx 9.95$

13. $\sqrt{123} \approx 11.09$

14. $\sqrt{2} \approx 1.41$

15. $\sqrt{2000} \approx 44.72$

16. $\sqrt{0.25} = 0.50$

17. $\sqrt{1.35} \approx 1.16$

18. $\sqrt{0.37} \approx 0.61$

19. $\sqrt{0.7} \approx 0.84$

20. $\sqrt{0.01} = 0.1$

21. real number, rational number

22. real number, irrational number

23. real number, irrational number

24. $\sqrt{25} = 5$ real number, rational number, whole number, and integer

25. $\sqrt{100} = 10$ real number, rational number, whole number, and integer

26. $\frac{\sqrt{6}}{2} \approx 1.224744871\dots$, $\frac{61}{50} = 1.22$, $\sqrt{1.5} \approx 1.224744871\dots$, $\frac{16}{13} \approx 1.23$

Therefore, the order is $\frac{61}{50}, \frac{\sqrt{6}}{2}, \sqrt{1.5}, \frac{16}{13}$ OR $\frac{61}{50}, \sqrt{1.5}, \frac{\sqrt{6}}{2}, \frac{16}{13}$

27.

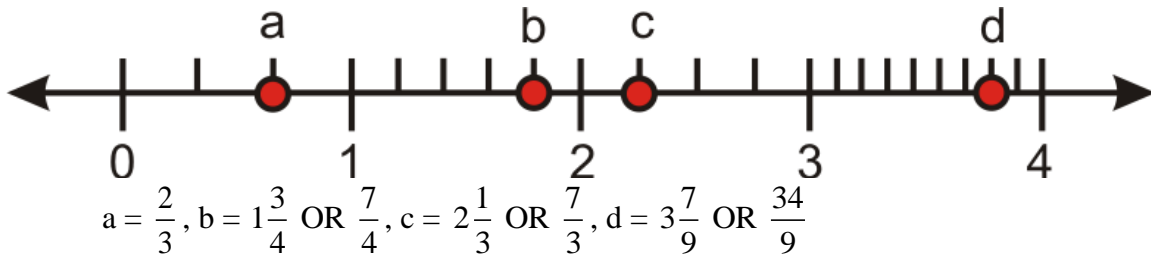

28. $\frac{9}{4} \div 6 = \frac{9}{4} \left(\frac{1}{6} \right) = \frac{9}{24} = \frac{3}{8}$

29. $A = \frac{3(7)}{2} = \frac{21}{2} = 10.5$ sq. ft.

30. $\frac{144 \div 6}{6 \div 6} = \frac{24}{1} = 24$

31.

x	y	$y = 60x$
0	0	$60(0) = 0$
1	60	$60(1) = 60$
2	120	$60(2) = 120$
3	180	$60(3) = 180$
4	240	$60(4) = 240$
5	300	$60(5) = 300$
6	360	$60(6) = 360$

Lesson 2.8

1. *Nadia's father is 36. He is 16 years older than four times Nadia's age. How old is Nadia?*

Using the equation defined in Example 3, we have $4 \times (\text{Nadia's age}) + 16 = 36$.

So $4 \times (\text{Nadia's age}) = 20$

Nadia's age = 5

2. Let N = the number of miles Nadia walks and P = the number of miles Peter walks. Then $N + P = 6$. We can then set up this table with our information.

	d	r	t
Nadia	d	3.5	t
Peter	$6 - d$	6	t
total	6	---	---

The total distance is 6 miles. Using the formula $d = rt$, we can write $6 = 3.5t + 6t$ (since they are traveling towards each other). We can solve for t to get how long it will take for them to meet.

$$6 = 3.5t + 6t$$

$$\underline{6 = 9.5t}$$

$$9.5 \quad 9.5$$

$$t \approx 0.6316 \text{ hours, or } 0.6316(60) \approx 37.9 \text{ minutes}$$

To find the distance from Nadia's home, use $d = rt$ where $r = 3.5$ and $t = 0.6316$ hours.

$$d = 3.5(0.6316) \approx 2.2 \text{ miles}$$

They will meet approximately 2.2 miles from Nadia's home.

3. Let R = the number of notebooks bought at Rite-Aid, and let S = the number of notebooks bought at Staples. Then we can write $R + S = 17$

We also know that $2.25S = 2R$.

If we solve the first equation for R , we get $R = 17 - S$.

Then,

$$2.25S = 2(17 - S)$$

$$2.25S = 34 - 2S$$

$$\underline{4.25S = 34}$$

$$4.25 \quad 4.25$$

$$S = 8$$

That means that $R = 17 - 8 = 11$.

Peter bought 11 notebooks at Rite-Aid and 8 notebooks at Staples.

4. Let d = the number of dimes and q = the number of quarters. We know that $d + q = 22$. We also know that $0.25q + 0.10d = 4$. We can take the first equation and solve for d .

$$d + q = 22$$

$$q = 22 - d$$

Now we can substitute that value into the other equation to get

$$0.25(22 - d) + 0.10d = 4$$

Now we can find the number of dimes.

$$0.25(22 - d) + 0.10d = 4$$

$$5.5 - 0.25d + 0.10d = 4$$

$$5.5 - 0.15d = 4$$

$$\underline{-0.15d = -1.5}$$

$$\begin{array}{r} -0.15 \\ -0.15 \end{array}$$

$$d = 10$$

We now know there are 10 dimes. We can find the number of quarters by using the equation $q = 22 - d = 22 - 10 = 12$. There are 12 quarters.

5. Let l = the length and w = the width. From the given information, we know that $l = 1.5w$. We also know that the formula for the perimeter of this rectangle is $2l + 2w = 50$. Using substitution, we get

$$2(1.5w) + 2w = 50$$

$$3w + 2w = 50$$

$$\underline{5w = 50}$$

$$\begin{array}{r} 5 \\ 5 \end{array}$$

$$w = 10 \text{ feet}$$

Then the length, $l = 1.5w = 1.5(10) = 15$ feet

The dimensions of the garden are 10 x 15 feet.

6. We know that every animal has a head, so $p + c = 13$ if p = pigs and c = chickens. Also, we know that each pig has 4 feet and each chicken has 2 feet, so $4p + 2c = 36$. We can solve the first equation for p to get $p = 13 - c$. Now substitute that into the second equation.

$$4(13 - c) + 2c = 36$$

$$52 - 4c + 2c = 36$$

$$\underline{-2c = -16}$$

$$\begin{array}{r} -2 \\ -2 \end{array}$$

$$c = 8$$

Substitute that into the first equation to get $p = 13 - 8 = 5$.

There were 8 chickens and 5 pigs.

7. The simple interest formula is $I = prt$, where I is the interest earned, p = the principle (original amount invested), r = the interest rate (as a decimal) and t = time (in years).

We know that $p_1 + p_2 = 8000$. From that we can write $p_2 = 8000 - p_1$.

We also know that $I = p_1r_1t + p_2r_2t$. Using substitution, we can write

$$I = p_1r_1t + (8000 - p_1)r_2t$$

$$450 = p_1(0.0525)(1) + (8000 - p_1)(0.09)(1)$$

$$450 = 0.0525p_1 + 720 - 0.09p_1$$

$$-270 = -0.375p_1$$

$$p_1 = 7,200$$

That means that $p_2 = 8000 - 7200 = 800$.

So, Andrew invested \$7,200 in the account with 5.25% interest rate and \$800 in the 9% account.

8. We will have to work backwards to solve this item. First, we need to know “16 is

$\frac{2}{3}$ of what number?”

$$16 = \frac{2}{3}x$$

$$x = 16\left(\frac{3}{2}\right) = 24.$$

Now, we need to know “24 is $\frac{4}{5}$ of what number?”

$$24 = \frac{4}{5}x$$

$$x = 24\left(\frac{5}{4}\right) = 30$$

Now we need to know “30 is $\frac{3}{4}$ of what number?”

$$30 = \frac{3}{4}x$$

$$x = 30\left(\frac{4}{3}\right) = 40$$

Finally, we need to know “40 is $\frac{5}{6}$ of what number?”

$$40 = \frac{5}{6}x$$

$$x = 40\left(\frac{6}{5}\right) = 48$$

There were 48 candies in the bowl at the beginning of the day.

9. First, let t = the amount of time it will take Nadia and Peter to mow the lawn together. Since it takes Nadia 30 minutes to mow, she can mow $\frac{1}{30}$ of the lawn each minute. Peter can mow it in 45 minutes, so he mows $\frac{1}{45}$ of the lawn each minute. Together, then can mow $\frac{1}{t}$ of the lawn each minute. Therefore, to find t , we add their rates together.

$$\frac{1}{30} + \frac{1}{45} = \frac{1}{t}$$

$$\frac{1(3)+1(2)}{90} = \frac{3+2}{90} = \frac{5}{90} = \frac{1}{t}$$

$$\text{So, } t = \frac{90}{5} = 18 \text{ minutes.}$$

Together, they can mow the lawn in 18 minutes.

10. $\sqrt{500} = \sqrt{100(5)} = 10\sqrt{5}$

11. $\frac{-2}{13}$ = rational number, real number

12. $\frac{1}{2}|19 - 65| - 14 = \frac{1}{2}(46) - 14 = 23 - 14 = 9$

13. Two properties are actually being used. The order was changed, so that is the commutative property of addition. The grouping was changed, so that is the associative property of addition.

14. This relation is not a function because every element in the domain is not mapped to only element in the range.

15. $y = \frac{1}{12}x - 5$ because $f(x) = \frac{1}{12}x - 5$

16. $\frac{36}{4} = 9$. Each case is \$9.

Lesson 2.9 Chapter 2 Review

- $7 > -11$
- $\frac{4}{5} = 0.8$ and $\frac{11}{16} = 0.6875$, so $\frac{4}{5} > \frac{11}{16}$
- If one reduces $\frac{10}{15}$, then it becomes $\frac{10 \div 5}{15 \div 5} = \frac{2}{3}$. Therefore, these two fractions are equal.
- $\frac{31}{32} = 0.96875$. Since $0.985 > 0.96875$, then $0.985 > \frac{31}{32}$.
- $-\frac{300}{9} \approx -33.\bar{3}$. Since $-16.12 > -33.\bar{3}$, then $-16.12 > -\frac{300}{9}$.
- Convert all three fractions to decimals to compare them.
 $\frac{8}{11} \approx 0.\overline{7272}$, $\frac{7}{10} = 0.7$, $\frac{5}{9} \approx 0.\overline{5555}$. Therefore, the correct order is $\frac{5}{9}, \frac{7}{10}, \frac{8}{11}$.
- Convert all the fractions to decimals to compare them.
 $\frac{2}{7} \approx 0.2857$, $\frac{1}{11} \approx 0.\overline{0909}$, $\frac{8}{13} \approx 0.6154$, $\frac{4}{7} \approx 0.5714$, $\frac{8}{9} \approx 0.\overline{8888}$. Therefore, the correct order is $\frac{1}{11}, \frac{2}{7}, \frac{4}{7}, \frac{8}{13}, \frac{8}{9}$.
- 12.

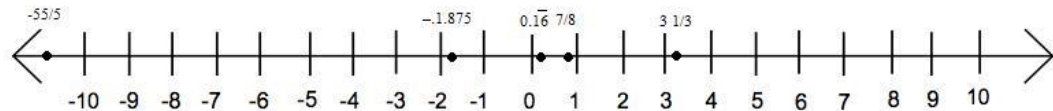

- $6n(-2 + 5n) - n(-3n - 8) = -12n + 30n^2 + 3n^2 + 8n = 33n^2 - 4n$
- $7x + 2(-6x + 2) = 7x - 12x + 4 = -5x + 4$
- $-7x(x + 5) + 3(4x - 8) = -7x^2 - 35x + 12x - 24 = -7x^2 - 13x - 24$

$$16. -3(-6r - 5) - 2r(1 + 6r) = 18r + 15 - 2r - 12r^2 = -12r^2 + 16r + 15$$

$$17. 1 + 3(p + 8) = 1 + 3p + 24 = 3p + 25$$

$$18. 3(1 - 5k) - 1 = 3 - 15k - 1 = -15k + 2$$

$$19. \sqrt{26} \approx 5.10$$

$$20. \sqrt{330} \approx 18.17$$

$$21. \sqrt{625} = 25.00$$

$$22. \sqrt{121} = 11.00$$

$$23. \sqrt{225} = 15.00$$

$$24. \sqrt{11} \approx 3.32$$

$$25. \sqrt{8} \approx 2.83$$

$$26. \sqrt{50} = \sqrt{25(2)} = 5\sqrt{2}$$

$$27. \sqrt{8} = \sqrt{4(2)} = 2\sqrt{2}$$

$$28. \sqrt{80} = \sqrt{16(5)} = 4\sqrt{5}$$

$$29. \sqrt{32} = \sqrt{16(2)} = 4\sqrt{2}$$

$$30. 8 + b + 1 - 7b = -6b + 9$$

$$31. 9n + 9n + 17 = 18n + 17$$

$$32. 7h - 3 + 3 = 7h$$

$$33. 9x + 11 - x - 3 + 5x + 2 = 13x + 10$$

$$34. \frac{8}{5} - \frac{4}{3} = \frac{8(3) - 4(5)}{15} = \frac{24 - 20}{15} = \frac{4}{15}$$

$$35. \frac{4}{3} - \frac{1}{2} = \frac{4(2) - 1(3)}{6} = \frac{8 - 3}{6} = \frac{5}{6}$$

$$36. \frac{1}{6} + 1\frac{5}{6} = \frac{1}{6} + \frac{11}{6} = \frac{12}{6} = 2$$

$$37. \frac{-5}{4} \times \frac{1}{3} = \frac{-5}{12} \text{ OR } -\frac{5}{12}$$

$$38. \frac{4}{9} \times \frac{7}{4} = \frac{7}{9}$$

$$39. -1\frac{5}{7} \times -2\frac{1}{2} = \frac{-12}{7} \times \frac{-5}{2} = \frac{60}{14} = \frac{30}{7} \text{ OR } 4\frac{2}{7}$$

$$40. \frac{1}{9} \div \left(-1\frac{1}{3}\right) = \frac{1}{9} \div \left(-\frac{4}{3}\right) = \frac{1}{9} \left(-\frac{3}{4}\right) = -\frac{1}{12}$$

$$41. \frac{-3}{2} \div \frac{-10}{7} = \frac{-3}{2} \left(\frac{-7}{10}\right) = \frac{21}{20}$$

$$42. -3\frac{7}{10} \div 2\frac{1}{4} = \frac{-37}{10} \div \frac{9}{4} = \frac{-37}{10} \left(\frac{4}{9}\right) = -\frac{74}{45} \text{ OR } -1\frac{29}{45}$$

$$43. 1\frac{1}{5} - \left(-3\frac{3}{4}\right) = \frac{6}{5} + \frac{15}{4} = \frac{6(4) + 15(5)}{20} = \frac{24 + 75}{20} = \frac{99}{20} \text{ OR } 4\frac{19}{20}$$

$$44. 4\frac{2}{3} + 3\frac{2}{3} = \frac{14}{3} + \frac{11}{3} = \frac{25}{3} \text{ OR } 8\frac{1}{3}$$

$$45. 5.4 + (-9.7) = -4.3$$

$$46. (-7.1) + (-0.4) = -7.5$$

$$47. (-4.79) + (-3.63) = -8.42$$

$$48. (-8.1) - (-8.9) = 0.8$$

$$49. 1.58 - (-13.6) = 15.18$$

$$50. (-13.6) + 12 - (-15.5) = 13.9$$

$$51. (-5.6) - (-12.6) + (-6.6) = 0.4$$

$$52. 19.4 + 24.2 = 43.6$$

$$53. 8.7 + 3.8 + 12.3 = 24.8$$

54. $9.8 - 9.4 = 0.4$
55. $2.2 - 7.3 = -5.1$
56. 10.9 is a real number and a rational number.
57. $\frac{-9}{10}$ is a real number and a rational number.
58. 3π is a real number and an irrational number.
59. $\frac{\pi}{2} - \frac{\pi}{2} = 0$ is a real number, a rational number, and an integer.
60. -21 is a real number, a rational number, and an integer.
61. 8 is a real number, a rational number, and an integer.
62. $6.78 + (-6.78) = 0$ – additive inverse property
63. $9.8 + 11.2 + 1.2 = 9.8 + 1.2 + 11.2$ – the order changed, so this is the commutative property of addition
64. $3a + (4a + 8) = (3a + 4a) + 8$ – the grouping changed, so this is the associative property of addition
65. $\frac{4}{3} - \left(-\frac{5}{6}\right) = \frac{4}{3} + \frac{5}{6}$ - additive inverse property
66. $(1)j = j$ – multiplicative identity
67. $8(11)\left(\frac{1}{8}\right) = 8\left(\frac{1}{8}\right)(11)$ - commutative property of multiplication
68. $18 + 132\left(\frac{1}{12}\right) = 18 + 11 = 29$ feet
69. $\frac{12}{\frac{3}{8}} = 12\left(\frac{8}{3}\right) = 32$ cookies
70. $11(20) - 11(0.01) = 220 - 0.11 = \219.89

71. $d = rt$, so We need to solve $14 = \frac{3}{8}t$ where $t =$ time in hours.

$$t = 14\left(\frac{8}{3}\right) = 37.\bar{3} \text{ hours}$$

72. $a = 4.8 + 1.2 + 68.48 + 32.45 + 0.16 = \107.09

73. $A = s^2$, so $145 = s^2$

$$\sqrt{145} = \sqrt{s^2}$$

$$s = \sqrt{145} \text{ meters}$$

Lesson 2.10 Chapter 2 Test

- $-3 + 7(3a - 2) = -3 + 21a - 14 = 21a - 17$
- $8(3 + 2q) + 5(q + 3) = 24 + 16q + 5q + 15 = 21q + 39$
- $8p - 5p = 3p$
- $9z + 33 - 2z - 15 = 7z + 18$
- $-\frac{9}{5} \div 2 = -\frac{9}{5} \left(\frac{1}{2} \right) = -\frac{9}{10}$
- $1\frac{6}{7} \times 5\frac{3}{4} = \frac{13}{7} \left(\frac{23}{4} \right) = \frac{299}{28}$ OR $10\frac{19}{28}$
- $\frac{1}{2} - 3\frac{2}{3} = \frac{1}{2} - \frac{11}{9} = \frac{1(9) - 11(2)}{18} = \frac{9 - 22}{18} = -\frac{13}{18}$
- $\frac{3}{14} + \frac{15}{8} = \frac{3(7) + 15(4)}{56} = \frac{21 + 60}{56} = \frac{81}{56}$ OR $1\frac{25}{56}$
- $3.5 - 5 - 10.4 = -11.9$
- $\frac{1}{6} - (-6.5) \times \frac{6}{5} = \frac{1}{6} - \left(-\frac{13}{2} \right) \times \frac{6}{5} = \frac{1}{6} - \left(-\frac{39}{5} \right) = \frac{1(5) + 39(6)}{30} = \frac{5 + 234}{30} = \frac{239}{30}$ OR $7\frac{29}{30}$
- $\sqrt{125} = \sqrt{25(5)} = 5\sqrt{5}$
- $\sqrt{18} = \sqrt{9(2)} = 3\sqrt{2}$
- The multiplicative inverse for any number x is $\frac{1}{x}$. Their product is 1. The additive inverse for any number x is $-x$. Their sum is 0.
- $A = s^2$, so $145 = s^2$
 $\sqrt{168} = \sqrt{s^2}$
 $s = 13.0$ miles
- Troy could create 16 piles. Each pile would contain 14 candles, and he would have 4 candles left over since $16(14) + 4 = 228$.

16. $-15 - 46.78 + 678.12 + x = \1123.45 , where x = the original amount in Laura's account.

$$616.34 + x = 1123.45$$

$$x = 1123.45 - 616.34 = \$507.11$$

17. The area of a circle will always be an irrational number since one has to multiply by π .

18. You would use the Commutative Property of Multiplication in order to make some problems easier to simplify. For example, if you had $3(4)\left(\frac{2}{3}\right)$, you could reorder the fractions to simplify the fraction first.

$$3(4)\left(\frac{2}{3}\right) = 3\left(\frac{2}{3}\right)(4) = 1(2)(4) = 8$$

Chapter 3
Lesson 3.1

$$\begin{array}{r} 1. \quad x + 11 = 7 \\ \quad -11 \quad -11 \\ \hline x = -4 \end{array}$$

$$\begin{array}{r} 2. \quad x - 1.1 = 3.2 \\ \quad + 1.1 \quad + 1.1 \\ \hline x = 4.3 \end{array}$$

$$\begin{array}{r} 3. \quad \frac{7x}{7} = \frac{21}{7} \\ \hline x = 3 \end{array}$$

$$\begin{array}{r} 4. \quad \frac{4x}{4} = \frac{1}{4} \\ \hline x = \frac{1}{4} \end{array}$$

$$\begin{array}{r} 5. \quad \frac{5x}{12} = \frac{2}{3} \\ (12) \frac{5x}{12} = \frac{2}{3} (12) \\ \frac{5x}{5} = \frac{8}{5} \\ \hline x = \frac{8}{5} \end{array}$$

$$\begin{array}{r} 6. \quad x + \frac{5}{2} = \frac{2}{3} \\ \quad -\frac{5}{2} \quad -\frac{5}{2} \\ \hline x = \frac{2}{3} - \frac{5}{2} = \frac{2(2) - 5(3)}{6} = \frac{4 - 15}{6} = -\frac{11}{6} \end{array}$$

$$\begin{array}{r} 7. \quad x - \frac{5}{6} = \frac{3}{8} \\ \quad +\frac{5}{6} \quad +\frac{5}{6} \\ \hline x = \frac{3}{8} + \frac{5}{6} = \frac{3(3) + 5(4)}{24} = \frac{9 + 20}{24} = \frac{29}{24} \text{ OR } 1\frac{5}{24} \end{array}$$

$$8. \frac{0.01x}{0.01} = \frac{11}{0.01}$$
$$x = 1,100$$

$$9. \begin{array}{r} q - 13 = -13 \\ +13 \quad +13 \\ \hline q = 0 \end{array}$$

$$10. \begin{array}{r} z + 1.1 = 3.001 \\ -1.1 \quad -1.1 \\ \hline z = 1.901 \end{array}$$

$$11. \frac{21s}{21} = \frac{3}{21}$$
$$s = \frac{3}{21} = \frac{1}{7}$$

$$12. \begin{array}{r} t + \frac{1}{2} = \frac{1}{3} \\ -\frac{1}{2} \quad -\frac{1}{2} \\ \hline t = \frac{1}{3} - \frac{1}{2} = \frac{1(2) - 1(3)}{6} = \frac{2 - 3}{6} = -\frac{1}{6} \end{array}$$

$$13. \frac{7f}{11} = \frac{7}{11}$$
$$\left(\frac{11}{7}\right) \frac{7f}{11} = \frac{7}{11} \left(\frac{11}{7}\right)$$
$$f = 1$$

$$14. \frac{3}{4} = -\frac{1}{2}y$$
$$(-2) \frac{3}{4} = -\frac{1}{2}y(-2)$$
$$-\frac{3}{2} = y$$

$$15. 6r = \frac{3}{8}$$

$$\frac{6r}{6} = \frac{\frac{3}{8}}{6}$$

$$r = \frac{\frac{3}{8}}{6} = \frac{3}{8} \left(\frac{1}{6} \right) = \frac{1}{16}$$

$$16. \frac{9b}{16} = \frac{3}{8}$$

$$\left(\frac{16}{9} \right) \frac{9b}{16} = \frac{3}{8} \left(\frac{16}{9} \right)$$

$$b = \frac{2}{3}$$

17. a) The number of tokens, n , he needs to collect can be found by $25 = 10 + n$.

b) He collects $\frac{10}{8}w = 1.25w$ tokens per week.

c) The number of weeks it will take him to send off for his boat is

$$r = 25 - 10 - 1.25w$$

$$r = 15 - 1.25w$$

18. a) The cost of making the cake is $\$8.50 + \$1.25 = \$9.75$. Three times this amount is $u = 9.75(3)$.

b) Each slice will be $c = \frac{9.75(3)}{12}$

c) Total profit is $9.75(3) - 9.75$.

19. To figure out how many hot dogs he ate in one minute, find the quotient

$$\frac{53.5}{12} \approx 4.46 \text{ hot dogs per minute.}$$

His old record was $53\frac{1}{2} - 3 = 50\frac{1}{2}$ hot dogs.

$$20. \sqrt{48} = \sqrt{16(3)} = 4\sqrt{3} \approx 6.928$$

21. 6.23 is a real number and a rational number

$$22. \frac{118 \div 2}{4 \div 2} = \frac{59}{2} \text{ OR } 29\frac{1}{2}$$

23.

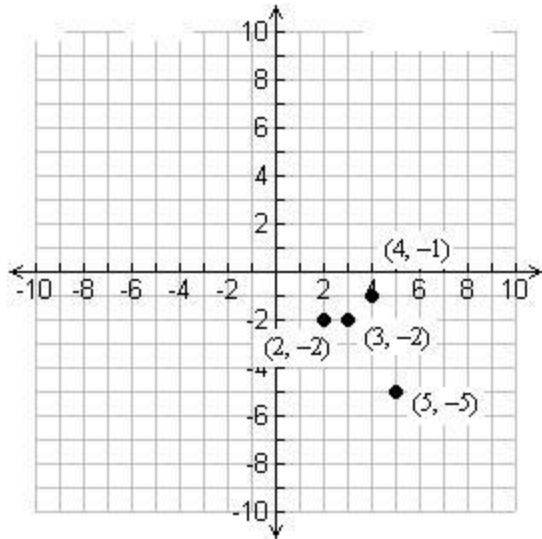

24. evaluate – means to follow the verbs in the math sentence. **Evaluate** can also be called simplify or answer.

25. The difference between m and n is 16.

26. $4(a + 11.2) = 4(a) + 4(11.2)$ represents the distributive property

Lesson 3.2

1. like terms - are expressions that have **identical** variable parts. (p. 90)

2. coefficient - numerical part of an algebraic term (p. 90)

3. $-7x + 39x = 32x$

4. $3x^2 + 21x + 5x + 10x^2 = 3x^2 + 10x^2 + 21x + 5x = 13x^2 + 26x$

5. $6xy + 7y + 5x + 9xy = 6xy + 9xy + 7y + 5x = 15xy + 7y + 5x$

6. $10ab + 9 - 2ab = 10ab - 2ab + 9 = 8ab + 9$

7. $-7mn - 2mn^2 - 2mn + 8 = -2mn^2 - 7mn - 2mn + 8 = -2mn^2 - 9mn + 8$

$$8. -5y - 9 = 74$$

First, we need to isolate the term with the variable ($-5y$), so we need to add 9 to both sides of the equation.

$$-5y - 9 = 74$$

$$+ 9 \quad + 9$$

$$-5y = 83$$

Then we need to get rid of the number multiplied by y (-5), so we divide both sides of the equation by that value.

$$\frac{-5y}{-5} = \frac{83}{-5}$$

$$-5 \quad -5$$

$$y = -\frac{83}{5} \text{ OR } -16\frac{3}{5}$$

$$9. 1.3x - 0.7x = 12$$

$$\frac{0.6x}{0.6} = \frac{12}{0.6}$$

$$0.6 \quad 0.6$$

$$x = 20$$

CHECK

$$1.3(20) - 0.7(20) = 12$$

$$26 - 14 = 12$$

$$12 = 12 \quad \checkmark$$

$$10. 6x - 1.3 = 3.2$$

$$+ 1.3 \quad + 1.3$$

$$\frac{6x}{6} = \frac{4.5}{6}$$

$$6 \quad 6$$

$$x = 0.75$$

CHECK

$$6(0.75) - 1.3 = 3.2$$

$$4.5 - 1.3 = 3.2$$

$$3.2 = 3.2 \quad \checkmark$$

$$11. 5x - (3x + 2) = 1$$

$$5x - 3x - 2 = 1$$

$$2x - 2 = 1$$

$$+ 2 \quad + 2$$

$$\frac{2x}{2} = \frac{3}{2}$$

$$2 \quad 2$$

$$x = \frac{3}{2}$$

CHECK

$$5\left(\frac{3}{2}\right) - \left[3\left(\frac{3}{2}\right) + 2\right] = \frac{15}{2} - \left(\frac{9}{2} + 2\right) = \frac{15}{2} - \left(\frac{9}{2} + \frac{4}{2}\right) = \frac{15}{2} - \frac{13}{2} = \frac{2}{2} = 1 \quad \checkmark$$

$$12. \begin{aligned} 4(x + 3) &= 1 \\ 4x + 12 &= 1 \\ &\quad - 12 \quad - 12 \end{aligned}$$

$$\frac{4x}{4} = \frac{-11}{4}$$

$$x = -\frac{11}{4}$$

CHECK

$$4\left(-\frac{11}{4} + 3\right) = 1$$

$$-11 + 12 = 1$$

$$1 = 1 \quad \checkmark$$

$$13. \begin{aligned} 5q - 7 &= \frac{2}{3} \\ &\quad + 7 \quad + 7 \\ 5q &= \frac{2}{3} + 7 = \frac{2}{3} + \frac{21}{3} = \frac{23}{3} \end{aligned}$$

$$\frac{5q}{5} = \frac{\frac{23}{3}}{5}$$

$$q = \frac{23}{3} \left(\frac{1}{5}\right) = \frac{23}{15}$$

CHECK

$$5\left(\frac{23}{15}\right) - 7 = \frac{2}{3}$$

$$\frac{23}{3} - \frac{21}{3} = \frac{2}{3}$$

$$\frac{2}{3} = \frac{2}{3} \quad \checkmark$$

$$14. \frac{3}{5}x + \frac{5}{2} = \frac{2}{3}$$

$$(30)\left(\frac{3}{5}x + \frac{5}{2}\right) = \left(\frac{2}{3}\right)(30)$$

$$18x + 75 = 20$$

$$\quad -75 \quad -75$$

$$\frac{18x}{18} = \frac{-55}{18}$$

$$x = -\frac{55}{18}$$

CHECK

$$\frac{3}{5}\left(-\frac{55}{18}\right) + \frac{5}{2} = \frac{2}{3}$$

$$\frac{-165}{90} + \frac{5}{2} = \frac{2}{3}$$

$$\frac{-165 + 225}{90} = \frac{2}{3}$$

$$\frac{60}{90} = \frac{2}{3}$$

$$\frac{2}{3} = \frac{2}{3} \quad \checkmark$$

$$15. s - \frac{3s}{8} = \frac{5}{6}$$

$$(24)\left(s - \frac{3s}{8}\right) = \left(\frac{5}{6}\right)(24)$$

$$24s - 9s = 20$$

$$15s = 20$$

$$s = \frac{4}{3}$$

CHECK

$$\frac{4}{3} - \frac{3\left(\frac{4}{3}\right)}{8} = \frac{5}{6}$$

$$\frac{4}{3} - \frac{4}{8} = \frac{5}{6}$$

$$\frac{4(8) - 4(3)}{24} = \frac{5}{6}$$

$$\frac{32 - 12}{24} = \frac{5}{6}$$

$$\frac{20}{24} = \frac{5}{6} \rightarrow \frac{5}{6} = \frac{5}{6} \quad \checkmark$$

$$16. 0.1y + 11 = 0$$

$$\quad - 11 \quad - 11$$

$$\frac{0.1y}{0.1} = \frac{-11}{0.1}$$

$$y = -110$$

CHECK

$$0.1(-110) + 11 = 0$$

$$-11 + 11 = 0$$

$$0 = 0 \quad \checkmark$$

$$17. \frac{5q-7}{12} = \frac{2}{3}$$

$$(12)\left(\frac{5q-7}{12}\right) = \left(\frac{2}{3}\right)(12)$$

$$5q - 7 = 8$$

$$\quad + 7 \quad + 7$$

$$\frac{5q}{5} = \frac{15}{5}$$

$$q = 3$$

CHECK

$$\frac{5(3)-7}{12} = \frac{2}{3}$$

$$\frac{8}{12} = \frac{2}{3}$$

$$\frac{2}{3} = \frac{2}{3} \quad \checkmark$$

$$18. \frac{5(q-7)}{12} = \frac{2}{3}$$

$$\left(\frac{12}{5}\right)\left(\frac{5(q-7)}{12}\right) = \left(\frac{2}{3}\right)\left(\frac{12}{5}\right)$$

$$q - 7 = \frac{8}{5}$$

$$\quad + 7 \quad + 7$$

$$q = \frac{8}{5} + 7 = \frac{8}{5} + \frac{35}{5} = \frac{43}{5}$$

CHECK

$$\frac{5\left(\frac{43}{5}-7\right)}{12} = \frac{2}{3}$$

$$\frac{43-35}{12} = \frac{2}{3}$$

$$\frac{8}{12} = \frac{2}{3}$$

$$\frac{2}{3} = \frac{2}{3} \quad \checkmark$$

$$19. 33t - 99 = 0$$

$$+ 99 \quad + 99$$

$$\frac{33t}{33} = \frac{99}{33}$$

$$t = 3$$

CHECK

$$33(3) - 99 = 0$$

$$99 - 99 = 0$$

$$0 = 0 \quad \checkmark$$

$$20. 5p - 2 = 32$$

$$+ 2 \quad + 2$$

$$\frac{5p}{5} = \frac{34}{5}$$

$$p = \frac{34}{5}$$

CHECK

$$5\left(\frac{34}{5}\right) - 2 = 32$$

$$34 - 2 = 32$$

$$32 = 32 \quad \checkmark$$

$$21. 14x + 9x = 161$$

$$\frac{23x}{23} = \frac{161}{23}$$

$$x = 7$$

CHECK

$$14(7) + 9(7) = 161$$

$$98 + 63 = 161$$

$$161 = 161 \quad \checkmark$$

$$22. 3m - 1 + 4m = 5$$

$$7m - 1 = 5$$

$$+ 1 \quad + 1$$

$$\frac{7m}{7} = \frac{6}{7}$$

$$m = \frac{6}{7}$$

CHECK

$$3\left(\frac{6}{7}\right) - 1 + 4\left(\frac{6}{7}\right) = 5$$

$$\frac{18}{7} - 1 + \frac{24}{7} = 5$$

$$\frac{18 - 7 + 24}{7} = 5$$

$$\frac{35}{7} = 5$$

$$5 = 5 \quad \checkmark$$

$$23. 8x + 3 = 11$$

$$- 3 \quad - 3$$

$$\frac{8x}{8} = \frac{8}{8}$$

$$x = 1$$

CHECK

$$8(1) + 3 = 11$$

$$8 + 3 = 11$$

$$11 = 11 \quad \checkmark$$

$$24. 24 = 2x + 6$$

$$- 6 \quad - 6$$

$$\frac{18}{2} = \frac{2x}{2}$$

$$9 = x$$

CHECK

$$24 = 2(9) + 6$$

$$24 = 18 + 6$$

$$24 = 24 \quad \checkmark$$

$$25. 66 = \frac{2}{3}k$$

$$\left(\frac{3}{2}\right)(66) = \left(\frac{2}{3}k\right)\left(\frac{3}{2}\right)$$

$$99 = k$$

CHECK

$$66 = \frac{2}{3}(99)$$

$$66 = 66 \checkmark$$

$$26. \frac{5}{8} = \frac{1}{2}(a+2)$$

$$(2)\frac{5}{8} = \frac{1}{2}(a+2)(2)$$

$$\frac{5}{4} = a+2$$

$$-2 \quad -2$$

$$\frac{5}{4} - 2 = a$$

$$\frac{5}{4} - \frac{8}{4} = a$$

$$-\frac{3}{4} = a$$

CHECK

$$\frac{5}{8} = \frac{1}{2}\left(-\frac{3}{4} + 2\right)$$

$$\frac{5}{8} = \frac{1}{2}\left(\frac{5}{4}\right)$$

$$\frac{5}{8} = \frac{5}{8} \checkmark$$

$$27. 16 = -3d - 5$$

$$+5 \quad +5$$

$$\underline{21} = \underline{-3d}$$

$$-3 \quad -3$$

$$-7 = d$$

CHECK

$$16 = -3(-7) - 5$$

$$16 = 21 - 5$$

$$16 = 16 \checkmark$$

28. Jayden's shoes cost $84.68(1.07) = \$90.61$.

29. Let h = the number of hours worked. Then we can write $98 + 60h = 498.00$.

$$\begin{array}{r} 98 + 60h = 498.00 \\ - 98 \qquad - 98 \end{array}$$

$$\frac{60h}{60} = \frac{400}{60}$$

$$h = 6.67 \text{ hours}$$

30. Let x = the amount of each payment. Then we can write $1195 = 250 + 5x$.

$$\begin{array}{r} 1195 = 250 + 5x \\ - 250 \quad - 250 \end{array}$$

$$\frac{945}{5} = \frac{5x}{5}$$

$$x = 189$$

Each payment will be \$189.

31. Let m = the number of miles. Then $2.35 + 0.75m = 10$.

$$\begin{array}{r} 2.35 + 0.75m = 10 \\ - 2.35 \qquad - 2.35 \end{array}$$

$$\frac{0.75m}{0.75} = \frac{7.65}{0.75}$$

$$m = 10.2 \text{ miles}$$

32. Let p = the number of people. Then $150 + 3p = 300$.

33. Trish did not carry the negative with her when she divided both sides by a number. She should have divided by -2 .

34. $d - 65 + 12 = 96$

35. domain: $0 \leq x \leq 10$

36. This relation is a function because it passes the vertical line test.

$$37. \frac{1}{2} - \frac{15}{9} = \frac{1(9) - 15(2)}{18} = \frac{9 - 30}{18} = -\frac{21}{18} = -\frac{7}{6}$$

38. The additive identity is 0. One can add any number to 0 and get that number.

39. The opposite of -4.1398 is 4.1398 .

Lesson 3.3

$$\begin{aligned} 1. \quad & 3(x-1) - 2(x+3) = 0 \\ & 3x - 3 - 2x - 6 = 0 \\ & x - 9 = 0 \\ & x = 9 \end{aligned}$$

$$\begin{aligned} 2. \quad & 7(w+20) - w = 5 \\ & 7w + 140 - w = 5 \\ & 6w + 140 = 5 \\ & \quad -140 \quad -140 \\ & \underline{6w = -135} \\ & \quad \quad \quad \underline{6} \quad \quad \quad \underline{6} \\ & w = -22.5 \end{aligned}$$

$$\begin{aligned} 3. \quad & 9(x-2) = 3x + 3 \\ & 9x - 2 = 3x + 3 \\ & -3x + 2 \quad -3x + 2 \\ & \underline{6x = 5} \\ & \quad \quad \underline{6} \quad \quad \underline{6} \\ & x = \frac{5}{6} \end{aligned}$$

$$2\left(5a - \frac{1}{3}\right) = \frac{2}{7}$$

$$5a - \frac{1}{3} = \frac{1}{7}$$

$$4. \quad 5a = \frac{1}{7} + \frac{1}{3} = \frac{1(3) + 1(7)}{21} = \frac{10}{21}$$

$$5a = \frac{10}{21}$$

$$a = \frac{10}{21} \left(\frac{1}{5}\right) = \frac{2}{21}$$

5.

$$\frac{2}{9} \left(i + \frac{2}{3}\right) = \frac{2}{5}$$

$$i + \frac{2}{3} = \frac{2}{5} \left(\frac{9}{2}\right)$$

$$i + \frac{2}{3} = \frac{9}{5}$$

$$i = \frac{9}{5} - \frac{2}{3} = \frac{9(3) - 2(5)}{15} = \frac{27 - 10}{15} = \frac{17}{15}$$

6.

$$4\left(v + \frac{1}{4}\right) = \frac{35}{2}$$

$$v + \frac{1}{4} = \frac{35}{2} \left(\frac{1}{4}\right)$$

$$v + \frac{1}{4} = \frac{35}{8}$$

$$v = \frac{35}{8} - \frac{1}{4} = \frac{35 - 1(2)}{8} = \frac{35 - 2}{8} = \frac{33}{8}$$

7. $\frac{22}{2} = \frac{2(p+2)}{2}$

$$11 = p + 2$$

$$-2 \quad -2$$

$$9 = p$$

8. $\frac{-(m+4)}{-1} = \frac{-5}{-1}$

$$m + 4 = 5$$

$$-4 \quad -4$$

$$m = 1$$

9. $\frac{48}{4} = \frac{4(n+4)}{4}$

$$12 = n + 4$$

$$-4 \quad -4$$

$$8 = n$$

10.

$$\left[\frac{6}{5}\left(v - \frac{3}{5}\right)\right] = \frac{6}{25}$$

$$25\left(\frac{6}{5}v - \frac{18}{25}\right) = \left(\frac{6}{25}\right)25$$

$$30v - 18 = 6$$

$$30v = 24$$

$$v = \frac{24}{30} = \frac{4}{5}$$

11. $\frac{-10(b-3)}{-10} = \frac{-100}{-10}$

$$b - 3 = 10$$

$$+3 \quad +3$$

$$b = 13$$

$$12. 6v + 6(4v + 1) = -6$$

$$6v + 24v + 6 = -6$$

$$30v + 6 = -6$$

$$\quad -6 \quad -6$$

$$30v = -12$$

$$v = -\frac{12}{30} = -\frac{2}{5}$$

$$13. -46 = -4(3s + 4) - 6$$

$$-46 = -12s - 16 - 6$$

$$-46 = -12s - 22$$

$$+ 22 \quad + 22$$

$$\underline{-24 = -12s}$$

$$-12 \quad -12$$

$$2 = s$$

$$14. 8(1 + 7m) + 6 = 14$$

$$\quad -6 \quad -6$$

$$8 + 56m = 8$$

$$-8 \quad -8$$

$$\underline{56m = 0}$$

$$56 \quad 56$$

$$m = 0$$

$$15. \underline{0 = -7(6 + 3k)}$$

$$-7 \quad -7$$

$$0 = 6 + 3k$$

$$-6 \quad -6$$

$$\underline{-6 = 3k}$$

$$3 \quad 3$$

$$-2 = k$$

$$16. \underline{35 = -7(2 - x)}$$

$$-7 \quad -7$$

$$-5 = 2 - x$$

$$-2 \quad -2$$

$$-7 = -x$$

$$7 = x$$

$$17. -3(3a + 1) - 7a = -35$$

$$-9a - 3 - 7a = -35$$

$$-16a - 3 = -35$$

$$+3 \quad +3$$

$$\underline{-16a = -32}$$

$$\underline{-16} \quad \underline{-16}$$

$$a = 2$$

18.

$$-2\left(n + \frac{7}{3}\right) = -\frac{14}{3}$$

$$n + \frac{7}{3} = -\frac{7}{3}$$

$$n = -\frac{7}{3} - \frac{7}{3} = -\frac{14}{3}$$

19.

$$-\frac{59}{60} = \frac{1}{6}\left(-\frac{4}{3}r - 5\right)$$

$$-60\left(-\frac{59}{60}\right) = \left(-\frac{4}{18}r - \frac{5}{6}\right)(-60)$$

$$59 = \frac{40}{3}r + 50$$

$$9 = \frac{40}{3}r$$

$$r = 9\left(\frac{3}{40}\right) = \frac{27}{40}$$

20.

$$7\left(\frac{4y+3}{7}\right) = 9(7)$$

$$4y + 3 = 63$$

$$4y = 60$$

$$y = 15$$

$$21. (c + 3) - 2c - (1 - 3c) = 2$$

$$c + 3 - 2c - 1 + 3c = 2$$

$$2c + 2 = 2$$

$$\underline{2c} = \underline{0}$$

$$\underline{2} \quad \underline{2}$$

$$c = 0$$

$$\begin{aligned}
22. \quad & 5m - 3[7 - (1 - 2m)] = 0 \\
& 5m - 3(7 - 1 + 2m) = 0 \\
& 5m - 3(6 + 2m) = 0 \\
& 5m - 18 - 6m = 0 \\
& -m - 18 = 0 \\
& -18 = m
\end{aligned}$$

$$\begin{aligned}
23. \quad & f - 1 + 2f + f - 3 = -4 \\
& 4f - 4 = -4 \\
& 4f = 0 \\
& f = 0
\end{aligned}$$

24. Let n = the first integer. Then the sum of 4 consecutive even integers will be

$$\begin{aligned}
& n + (n + 2) + (n + 4) + (n + 6) = 244 \\
& 4n + 12 = 244 \\
& 4n = 244 - 12 \\
& \frac{4n}{4} = \frac{232}{4} \\
& n = 58
\end{aligned}$$

This tells us the 4 consecutive even integers are 58, 60, 62, and 64.

25. Let x = the number. Then

$$\begin{aligned}
& \frac{2}{3}x + 4 = 22 \\
& \frac{3}{2} \left(\frac{2}{3}x \right) = (18) \frac{3}{2} \\
& x = 27
\end{aligned}$$

26. Let p = the price of the pear. We know that the juice = $1.5p$ and the sandwich = $p + 1.40$. The total is 3.50. So,

$$\begin{aligned}
& 3.50 = p + 1.5p + (p + 1.40) \\
& 3.50 = 3.5p + 1.40 \\
& \frac{2.10}{3.5} = \frac{3.5p}{3.5} \\
& p = 0.60 \\
& \text{The pear costs } \$0.60.
\end{aligned}$$

27. Let l = the number of laptops. Then

$$\begin{aligned}
& 5l = \text{number of desktops} \\
& \frac{5l}{5} = \frac{65}{5} \\
& l = 13 \\
& \text{The school has 13 laptops.}
\end{aligned}$$

28.

$$\frac{7}{100} = \frac{\text{commission}}{\text{sale price}}$$

$$\frac{7}{100} = \frac{5,389.12}{s}$$

$$7s = 538,912$$

$$s = \$76,987.43$$

The sale price is \$76,987.43.

29. $1\frac{6}{7} \times \frac{2}{3} = \frac{13}{7} \times \frac{2}{3} = \frac{26}{21}$ OR $1\frac{5}{21}$

30. evaluate – means to follow the verbs in the math sentence. **Evaluate** can also be called simplify or answer.

31. $\sqrt{75} = \sqrt{25(3)} = 5\sqrt{3}$

32.

$$9\left(\frac{1}{9}m\right) = (12)9$$

$$m = 108$$

33. $((-5) - (-7) - (-3)) \times (-10)$

$$(-5 + 7 + 3) \times (-10)$$

$$5 \times (-10)$$

$$-50$$

34. $0.125 - \frac{1}{5} = 0.125 - .2 = -0.075$

Lesson 3.4

$$\begin{aligned} 1. \quad & 3(x-1) = 2(x+3) \\ & 3x - 3 = 2x + 6 \\ & -2x + 3 = -2x + 3 \\ & x = 9 \end{aligned}$$

$$\begin{aligned} 2. \quad & 7(x+20) = x+5 \\ & 7x + 140 = x+5 \\ & -x -140 = -x -140 \\ & \underline{6x = -135} \\ & \quad \quad \quad 6 \quad \quad \quad 6 \\ & x = 22.5 \end{aligned}$$

$$\begin{aligned} 3. \quad & 9(x-2) = 3x+3 \\ & 9x - 18 = 3x+3 \\ & -3x + 18 = -3x + 18 \\ & \underline{6x = 21} \\ & \quad \quad \quad 6 \quad \quad \quad 6 \\ & x = \frac{21}{6} = \frac{7}{2} \end{aligned}$$

$$\begin{aligned} 4. \quad & 2\left(a - \frac{1}{3}\right) = \frac{2}{5}\left(a + \frac{2}{3}\right) \\ & 2a - \frac{2}{3} = \frac{2}{5}a + \frac{4}{15} \\ & -\frac{2}{5}a + \frac{2}{3} = -\frac{2}{5}a + \frac{2}{3} \\ & 2a - \frac{2}{5}a = \frac{4}{15} + \frac{2}{3} \\ & \frac{10a - 2a}{5} = \frac{4 + 10}{15} \\ & \frac{5}{8}\left(\frac{8a}{5}\right) = \left(\frac{14}{15}\right)\frac{5}{8} \\ & a = \frac{7}{12} \end{aligned}$$

5.

$$35 \left[\frac{2}{7} \left(t + \frac{2}{3} \right) \right] = \left[\frac{1}{5} \left(t - \frac{2}{3} \right) \right] 35$$

$$10 \left(t + \frac{2}{3} \right) = 7 \left(t - \frac{2}{3} \right)$$

$$10t + \frac{20}{3} = 7t - \frac{14}{3}$$

$$3t = -\frac{34}{3}$$

$$t = -\frac{34}{9}$$

6.

$$\frac{1}{7} \left(v + \frac{1}{4} \right) = 2 \left(\frac{3v}{2} - \frac{5}{2} \right)$$

$$28 \left(\frac{1}{7} v + \frac{1}{28} \right) = (3v - 5) 28$$

$$4v + 1 = 84v - 140$$

$$141 = 80v$$

$$v = \frac{141}{80}$$

7.

$$\frac{y-4}{11} = \frac{2}{5} \frac{2y+1}{3}$$

$$165 \left(\frac{y-4}{11} \right) = \left(\frac{4y+2}{15} \right) 165$$

$$15y - 60 = 44y + 22$$

$$-82 = 29y$$

$$y = -\frac{82}{29}$$

8.

$$144 \left[\frac{z}{16} \right] = \left[\frac{2(3z+1)}{9} \right] 144$$

$$9z = 32(3z+1)$$

$$9z = 96z + 32$$

$$87z = -32$$

$$z = -\frac{32}{87}$$

9.

$$\frac{q}{16} + \frac{q}{6} = \frac{(3q+1)}{9} + \frac{3}{2}$$

$$\frac{q(3) + q(8)}{48} = \frac{2(3q+1) + 3(9)}{18}$$

$$144 \left(\frac{11q}{48} \right) = \left(\frac{6q+29}{18} \right) 144$$

$$33q = 48q + 232$$

$$15q = -232$$

$$q = -\frac{232}{15}$$

10. $21 + 3b = 6 - 6(1 - 4b)$

$$21 + 3b = 6 - 6 + 24b$$

$$21 + 3b = 24b$$

$$21 = 21b$$

$$b = 1$$

11. $-2x + 8 = 8(1 - 4x)$

$$-2x + 8 = 8 - 32x$$

$$30x = 0$$

$$x = 0$$

12. $3(-5v - 4) = -6v - 39$

$$-15v - 12 = -6v - 39$$

$$9v = 27$$

$$v = 3$$

13. $-5(5k + 7) = 25 + 5k$

$$-25k - 35 = 25 + 5k$$

$$-60 = 30k$$

$$k = -2$$

14. $5x - 3 = (x + 5)3$

$$5x - 3 = 3x + 15$$

$$2x = 18$$

$$x = 9$$

15. Let c = the original price of one CD.

$$5c + 6 = 9(c - 4) + 2$$

$$5c + 6 = 9c - 36 + 2$$

$$5c + 6 = 9c - 34$$

$$40 = 4c$$

$$c = 10$$

Since the original price is \$10, then the sale price is $10 - 4 = \$6$.

16. Let w = the number of weeks.

$$412 + 18w = 874 - 44w$$

$$62w = 462$$

$$w \approx 7.45$$

They will have the same amount in about 7.5 weeks.

17. a. Let t = the number of texts.

$$75 + 0.05t = 109$$

$$0.05t = 34$$

$$t = 680 \text{ texts}$$

b. Plan B is better because after 680 texts, Plan A would cost more than Plan B.

18. a. Let h = the number of hours.

$$150 = 7.75h$$

$$h = 19.35 \text{ hours}$$

b. Choose Modern Rental because after 19.35 hours, Budgetwise will cost more.

19. $-12 + t = -20$

$$+ 12 \quad + 12$$

$$t = -8$$

20. $3r - 7r = 32$

$$-4r = 32$$

$$r = -8$$

21. $35 = 5(e + 2)$

$$7 = e + 2$$

$$5 = e$$

$$22. 4n + 25 = 13$$

$$4n = -12$$

$$n = -3$$

$$23. \text{ The opposite of } 9\frac{1}{5} \text{ is } -9\frac{1}{5}, \text{ which is equal to } -\frac{46}{5}.$$

$$24. (|b| - a) - (|d| - a) = (|-6| - 4) - (|5| - 4) = (6 - 4) - (5 - 4) = 2 - 1 = 1$$

25. -3 is an integer that is not a counting number. Any negative number is acceptable.

Quick Quiz

1. The inverse of addition is subtraction.

$$2. \frac{-4w}{-4} = \frac{16}{-4}$$

$$w = -4$$

3. Let t = Shauna's previous time.

$$56.7 = t - 0.98$$

$$t = 57.68 \text{ seconds}$$

$$4. \frac{1}{2}b + 5 = 9$$

$$\frac{1}{2}b = 9 - 5$$

$$2\left(\frac{1}{2}b\right) = (4)2$$

$$b = 8$$

5.

$$3q + 5 - 4q = 19$$

$$-q + 5 = 19$$

$$-q = 14$$

$$q = -14$$

Lesson 3.5

1. \$150 to \$3 becomes $\frac{150}{3} = \frac{50}{1} = 50$
2. 150 boys to 175 girls becomes $\frac{150}{175} = \frac{6}{7}$
3. 200 minutes to 1 hour becomes $\frac{200}{60} = \frac{10}{3}$
4. 10 days to 2 weeks = $\frac{10}{14} = \frac{5}{7}$
5. $\frac{54}{12} = \frac{9}{2}$ hotdogs/minute
6. $\frac{5,000}{250} = \frac{20}{1} = 20$ lbs/in²
7. $\frac{20}{80} = \frac{1}{4}$ computers/student
8. $\frac{180}{6} = \frac{30}{1} = 30$ students/teacher
9. $\frac{12}{4} = 3$ meters/floor
10. $\frac{18}{15} = \frac{6}{5}$ minutes/appointment
11. There is more than one correct answer. One example is $\frac{30}{5} = \frac{6}{1}$. You could also flip both fractions, or swap the 5 and 6.
12. The means are 12 and 35 and the extremes are 5 and 84.
13. $\frac{13}{6} = \frac{5}{x}$
 $13x = 30$
 $x = \frac{30}{13}$
14. $\frac{1.25}{7} = \frac{3.6}{x}$
 $1.25x = 25.2$
 $x = 20.16$

$$15. \frac{6}{19} = \frac{x}{11}$$
$$19x = 66$$
$$x = \frac{66}{19}$$

$$16. \frac{1}{x} = \frac{0.01}{5}$$
$$0.01x = 5$$
$$x = 500$$

$$17. \frac{300}{4} = \frac{x}{99}$$
$$4x = 29,700$$
$$x = 7,425$$

$$18. \frac{2.75}{9} = \frac{x}{\left(\frac{2}{9}\right)}$$
$$9x = 0.6\bar{1}$$
$$x \approx 0.68$$

$$19. \frac{1.3}{4} = \frac{x}{1.3}$$
$$4x = 1.69$$
$$x = 0.4225$$

$$20. \frac{0.1}{1.01} = \frac{1.9}{x}$$
$$0.1x = 1.919$$
$$x = 19.19$$

$$21. \frac{5p}{12} = \frac{3}{11}$$
$$55p = 36$$
$$p = \frac{36}{55}$$

$$22. -\frac{9}{x} = \frac{4}{11}$$
$$4x = -99$$
$$x = -24.75$$

$$23. \frac{n+1}{11} = -2$$

$$n + 1 = -22$$

$$n = -23$$

$$24. \frac{100}{908} = \frac{250}{x}$$

$$100x = 227,000$$

$$x = 2,270$$

25. Let y = the height of Mount Yukon, b = the height of Ben Nevis, e = Mount Elbert.

$$\text{Then } b = \frac{44}{48}(4800) = 4400 \text{ meters}$$

$$e = \frac{220}{67}(4400) = 14,447.76 \text{ meters}$$

$$y = \frac{298}{67}(14,447.76) = 64,260.19 \text{ meters}$$

Mount Yukon is about 64,260.19 meters tall.

26. Since 2 out of 3 students have a cell phone and 1 out of 5 of them are one year old

or less, then $\frac{2}{3}\left(\frac{1}{5}\right) = \frac{2}{15}$ have cell phones that are one year old or less. This

means that the ratio of students that have cell phones more than one year old is $\frac{13}{15}$.

27. $\frac{\text{Amazon}}{\text{used price}} = \frac{\$10.00}{\$6.50} \approx 1.54$. The Amazon price is about 1.54 times the used price.

$\frac{\text{used price}}{\text{Amazon}} = \frac{\$6.50}{\$10.00} = 0.65$. The used price is 0.65 times the Amazon price.

28. The unit price can be found by dividing the total price by the number of items.

$$\frac{\$8.79}{10} = \frac{\$5.80}{x}$$

$$8.79x = 58$$

$$x = \frac{58}{8.79} \approx 6.6$$

You can buy 6 notebooks, since you do not have quite enough to buy 7.

$$29. \frac{1 \text{ cup mix}}{6 \text{ pancakes}} = \frac{x \text{ cups mix}}{21 \text{ pancakes}}$$

$$\text{So, } 6x = 21$$

$x = 3.5$ cups mix needed for 21 pancakes

$$\frac{\frac{3}{4} \text{ cup water}}{6 \text{ pancakes}} = \frac{y \text{ cups water}}{21 \text{ pancakes}}$$

$$6y = 15.75$$

$$y = 2.625 \text{ cups OR } 2\frac{5}{8} \text{ cups}$$

$$30. \frac{1 \text{ N}}{3 \text{ H}} = \frac{x \text{ N}}{1,983 \text{ H}}$$

$$1,983 = 3x$$

$x = 661$ H atoms

$$31. \frac{5 \text{ won}}{9 \text{ games}} = \frac{x \text{ won}}{63 \text{ games}}$$

$$9x = 315$$

$x = 35$ games won

32. First, we need to convert the time 7 hours to minutes, so $7(60) = 420$ minutes. Then we can set up our proportion is:

$$\frac{15 \text{ miles}}{20 \text{ minutes}} = \frac{x \text{ miles}}{420 \text{ minutes}}$$

$$20x = 6300$$

$x = 315$ miles

$$33. \frac{15}{16} \div \frac{5}{8} = \frac{15}{16} \times \frac{8}{5} = \frac{3}{2}$$

$$34. |9 - 108| = |-99| = 99$$

$$35. 8(8 - 3x) - 2(1 + 8x) = 64 - 24x - 2 - 16x = 62 - 40x$$

$$36. \frac{7(n+7)}{7} = \frac{-7}{7}$$

$$n + 1 = -1$$

$$-1 \quad -1$$

$$n = -2$$

$$37. -22 = -3 + x$$

$$+3 \quad +3$$

$$x = -19$$

$$38. \frac{18}{2} = \frac{2u}{2}$$

$$u = 9$$

$$39. -\frac{1}{7} - \left(-1\frac{1}{3}\right) = -\frac{1}{7} + \frac{4}{3} = \frac{-1(3) + 4(7)}{21} = \frac{-3 + 28}{21} = \frac{25}{21}$$

$$40. 5 \times \frac{p}{6} |n| = 5 \times \frac{-6}{6} |10| = 5 \times (-1)(10) = -50$$

41.

x	Work shown	$f(x) = \frac{1}{8}x + 2$
-4	$f(-4) = \frac{1}{8}(-4) + 2 = -\frac{1}{2} + 2 = \frac{3}{2}$	$\frac{3}{2}$
-3	$f(-3) = \frac{1}{8}(-3) + 2 = -\frac{3}{8} + 2 = \frac{-3 + 16}{8} = \frac{13}{8}$	$\frac{13}{8}$
-2	$f(-2) = \frac{1}{8}(-2) + 2 = -\frac{1}{4} + 2 = \frac{7}{4}$	$\frac{7}{4}$
-1	$f(-1) = \frac{1}{8}(-1) + 2 = -\frac{1}{8} + 2 = \frac{15}{8}$	$\frac{15}{8}$
0	$f(0) = \frac{1}{8}(0) + 2 = 2$	2
1	$f(1) = \frac{1}{8}(1) + 2 = \frac{1}{8} + 2 = \frac{17}{8}$	$\frac{17}{8}$
2	$f(2) = \frac{1}{8}(2) + 2 = \frac{1}{4} + 2 = \frac{9}{4}$	$\frac{9}{4}$
3	$f(3) = \frac{1}{8}(3) + 2 = \frac{3}{8} + \frac{16}{8} = \frac{19}{8}$	$\frac{19}{8}$
4	$f(4) = \frac{1}{8}(4) + 2 = \frac{1}{2} + 2 = \frac{5}{2}$	$\frac{5}{2}$

42. $y + 11$ becomes: eleven added to a number, y

Lesson 3.6

1. Similar figures are figures that have the same shape and all corresponding sides are proportional.
2. All the corresponding sides have the same ratio.
3. Indirect measurement utilizes similar figures to determine the measurement of an object that cannot be measured directly, like a tall building.
4. Law of Reflection – The angle that the light reflects off a mirror is the same as the angle that hits the mirror. This law can be used to show that two right triangles are similar. If the two triangles are similar, then proportions can be used to determine the length or height of an object.

5.
$$\frac{1 \text{ inches}}{20 \text{ miles}} = \frac{x \text{ inches}}{1,214 \text{ miles}}$$
$$20x = 1,214$$
$$x = 60.7 \text{ inches}$$

6. 1 mile : 1 mile would mean that there is no scaling from a map to the real space. The problem is that there would not be enough paper to create a drawing if the map covered too much distance.

7. We are going to use the proportion $\frac{\text{height}}{\text{shadow}} = \frac{\text{height}}{\text{shadow}}$. So,

$$\frac{66 \text{ inches}}{34 \text{ inches}} = \frac{h \text{ inches}}{99 \text{ inches}}$$

$$34h = 6,534$$

$$h = 192.2 \text{ inches}$$

The tree is approximately 192.2 inches tall.

8.
 - a. The length of the helicopter is 21 feet, which is found by measuring the length of the drawing and using the scale to determine actual length.
 - b. The height of the helicopter is 10 feet.
 - c. Each rotor is 12 feet.
 - d. The cabin is 5 feet wide.
 - e. The diameter of the rear rotor is 4 feet.

9. First, we need to convert $5\frac{1}{4}$ inches to feet (in decimal form).

$$5\frac{1}{4} = \frac{21}{4} \text{ inches}$$

$$\frac{21}{4} \left(\frac{1 \text{ foot}}{12 \text{ inches}} \right) = \frac{21}{48} = 0.4375 \text{ inches}$$

We are going to use the proportion $\frac{\text{height}}{\text{shadow}} = \frac{\text{height}}{\text{shadow}}$. So,

$$\frac{3 \text{ feet}}{5.4375 \text{ feet}} = \frac{h \text{ feet}}{600 \text{ feet}}$$

$$5.4375h = 1,800$$

$$h = 331.03 \text{ feet}$$

10. $\frac{12.4 \text{ inches}}{x \text{ miles}} = \frac{1.2 \text{ inches}}{15 \text{ miles}}$

$$1.2x = 186$$

$$x = 155 \text{ miles}$$

The cities are 155 miles apart.

11. $\frac{\text{height}}{\text{shadow}} = \frac{\text{height}}{\text{shadow}}$

$$\frac{6}{9} = \frac{h}{6}$$

$$9h = 36$$

$$h = 4 \text{ feet}$$

The dog is 4 feet tall.

12. $\frac{3 \text{ inches}}{4 \text{ meters}} = \frac{12 \text{ inches}}{w \text{ meters}}$

$$3w = 48$$

$$w = 16 \text{ meters}$$

The house is 16 meters wide.

13. We can use the figure to answer the question.

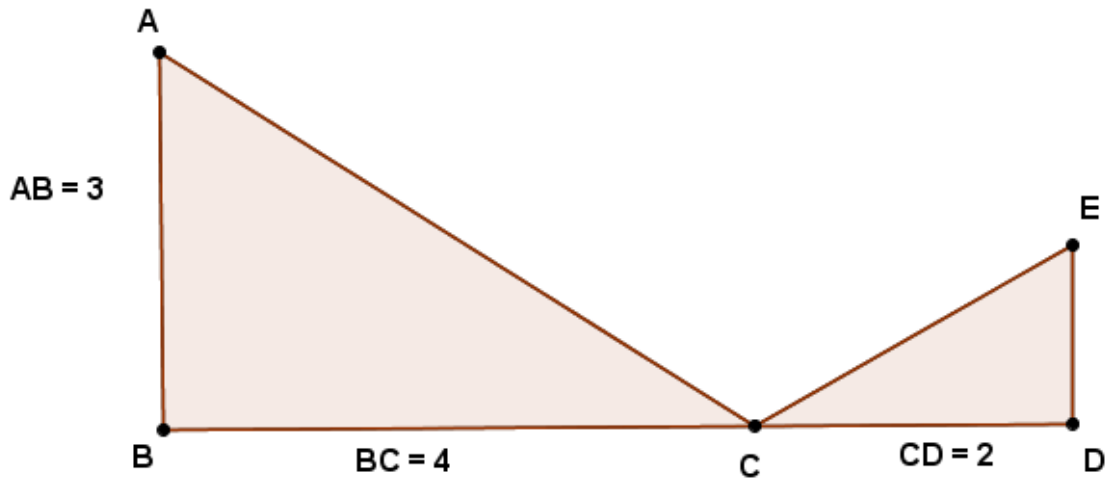

$$\frac{BC}{CD} = \frac{AB}{DE} \Rightarrow \frac{4}{2} = \frac{3}{DE}$$

$$4DE = 6$$

$$DE = 1.5 \text{ units}$$

14. $\frac{\text{height}}{\text{shadow}} = \frac{\text{height}}{\text{shadow}}$

Since $\frac{5}{12} \approx 0.4167$

$$\frac{42.9}{253.1} = \frac{5.4167}{s}$$

$$42.9s = 1370.96677$$

$$s = 31.96 \text{ feet}$$

The woman's shadow is about 31.96 feet.

15. $-(7 - 7a) + 4a = -23 + 3a$

$$-7 + 7a + 4a = -23 + 3a$$

$$-7 + 11a = -23 + 3a$$

$$8a = -16$$

$$a = -2$$

16. Evaluating requires one to substitute a known quantity into an expression and simplify. For example, $3x + 2$ when $x = -4$ becomes $3(-4) + 2 = -12 + 2 = -10$.

Solving requires one to solve an equation for an unknown quantity, such as

$$3x + 2 = 11$$

$$3x = 9$$

$$x = 3$$

17. $\sqrt{243} = \sqrt{81(3)} = 9\sqrt{3} \approx 15.6$

18. $2(8g + 2) - 1 + 4g - 2(2 - 5g) = 16g + 4 - 1 + 4g - 4 + 10g = 30g - 1$

19. There are many possible answers. One example of a relation that is not a function

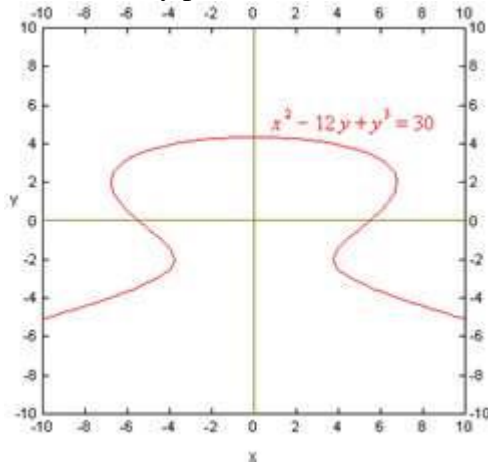

is

It is not a function because it does not pass the Vertical Line Test.

20. Let j = the amount of money Jose has. We know that Huey = \$26, and Chloe = Huey - 4 = \$22. Then we know

$$j = \frac{2}{3}(22) = \frac{44}{3} \approx 14.67.$$

Jose has about \$14.67.

Lesson 3.7

1. $0.011(100\%) = 1.1\%$
2. $0.001(100\%) = 0.1\%$
3. $0.91(100\%) = 91\%$
4. $1.75(100\%) = 175\%$
5. $20(100\%) = 2000\%$
6. $\frac{1}{6} \approx 0.1667(100\%) = 16.67\%$
7. $\frac{5}{24} \approx 0.2083(100\%) = 20.83\%$
8. $\frac{6}{7} \approx 0.8571(100\%) = 85.71\%$
9. $\frac{11}{7} \approx 1.5714(100\%) = 157.14\%$
10. $\frac{13}{97} \approx 0.1340(100\%) = 13.40\%$
11. $11\% = \frac{11}{100}$
12. $65\% = \frac{65}{100} = \frac{13}{20}$
13. $16\% = \frac{16}{100} = \frac{4}{25}$
14. $12.5\% = \frac{125}{1000} = \frac{1}{8}$
15. $87.5\% = \frac{875}{1000} = \frac{7}{8}$
16. $0.32(600) = x$
 $192 = x$

17. $0.75\% = 0.0075$
 $0.0075(16) = x$
 $0.12 = x$

18. $0.092(500) = x$
 $46 = x$

19. $8 = 0.20x$
 $x = \frac{8}{0.20} = 40$

20. $99 = 1.80x$
 $x = \frac{99}{1.8} = 55$

21. $7.2x = 45$
 $x = \frac{45}{7.2} = 6.25(100\%) = 625\%$

22. $1.50x = 5$
 $x = \frac{5}{150} \approx 0.033(100\%) = 3.3\%$

23. $50x = 2500$
 $x = \frac{2500}{50} = 50(100\%) = 5,000\%$

24. The realtor earned $0.075(215,000) = \$16,125$ in commission.

25. $\frac{1,750}{30,000} \approx 0.0583(100\%) = 5.83\%$

26. The shirt was discounted $\$49.99 - \$29.99 = \$20$. Therefore, the shirt was discounted $\frac{20}{49.99} = 0.40(100\%) = 40\%$.

27. Let p = the pre-sale price. We know that the % difference = amount of change/the pre-sale price.

We can determine the sale percent as $100\% - 35\% = 65\%$.

We need to know "195 is 65% of what number?"

$$195 = 0.65p$$

$$p = \frac{195}{0.65} \approx 300$$

The pre-sale price for the shirt is \$300.

28. New rate = $9.50(100\% + 12\%) = 9.50(1.12) = \$10.64/\text{hour}$

29. Let p = the original purchase price for the stores. Then the selling price for Store A = $1.4p$ and the selling price for store B = $1.9p$.

With the permanent sale, Store B's new price = $(0.6)(1.9p) = 1.14p$ which is a better deal than Store A.

30. $788(0.18) = 141.84$

About 142 students said their favorite show was reality-based.

31.

Step	Property
$4(x - 3) = 20$	given
$4x - 12 = 20$	Distributive Property of Equality
$4x = 20$	Addition Property of Equality
$x = 5$	Division Property of Equality

32. $V = \pi r^2 h = \pi(3)^2(5.5) \approx 155.51 \text{ in}^3$

33. *Jerry makes holiday baskets for his youth group.*

He can make one every 50 minutes. How many baskets can Jerry make in 25 hours?

34. A table can be used when there is a lot of data, or when organizing the data would help figure out a process. It is not useful if someone needs to work backwards, or there is not enough information where a table would be needed.

35. $\frac{10}{w} = \frac{12}{3}$

$$12w = 30$$

$$w = 2.5$$

Lesson 3.8

1. The dimensions of the sandbox are 5 feet by 8 feet, so the area of the base = $5(8) = 40$ sq. ft.

Let x = the height of the sand

The volume of the sand = 30 cubic feet, so the height of the sand is

$$40x = 30$$

$$x = 0.75 \text{ inches.}$$

Therefore, the height of the box should be $0.75 + 4 = 4.75$ inches.

2. First, how many stacks of 1.75 inch paper can be stacked to get 2 feet (24 inches)?

$$\frac{24}{1.75} \approx 13.71 \text{ stacks}$$

Now, we can determine about how many sheets by multiplying.

$$13.71(500) = 6,855 \text{ sheets}$$

3. We first need to determine the price of the shoes with the 20% discount applied.

$$\$36(0.8) = \$28.80$$

$$\text{The price with the coupon is } \$28.80(0.9) = \$25.92$$

4. To determine the amount of time for the sound to reach the audience, we will use this method.

$$20 \text{ meters} \left(\frac{1 \text{ second}}{340 \text{ meters}} \right) = \frac{20}{340} = 0.059 \text{ seconds}$$

It is important to put the dimensions we want to cancel out on the top of one fraction and the bottom of the other fraction. This leaves only the desired dimension.

5. Let x = the amount of money she can spend on the vacation. Then we can determine the equation we need to use by looking at the percents.

Since she spent 30% on the vacation, that means that she spent 70% of the vacation amount (x) on clothes.

$$\text{So we can write } x + 0.7x = 1,000$$

$$1.7x = 1000$$

$$x \approx \$588$$

She spent approximately \$588 on vacation, so she spent about $1000 - 588 = \$412$ on clothes.

6. The formula for the area of a circle is $A = \pi r^2$, where r = the radius.

The area of the larger circle is $A = \pi(5.7)^2 \approx 102.07$ sq. cm.

The area of the smaller circle is $A = \pi(2.3)^2 \approx 16.62$ sq. cm.

So, the area available for storage is $102.07 - 16.62 = 85.45$ sq cm.

7. We will need the information from the previous item. We know the area is 85.45

$$\text{sq. cm. Density} = \frac{\text{data}}{\text{area}} = \frac{25 \text{ GB}}{85.45 \text{ sq. cm.}} = 0.29 \text{ GB/sq.cm.}$$

8. $V = \frac{\pi r^2 h}{3} = \frac{\pi(0.75)^2(5)}{2} \approx 4.42$ cubic inches

9. $\frac{39.37 \text{ inches}}{1 \text{ meter}} \left(\frac{1,000 \text{ meters}}{1 \text{ kilometer}} \right) = 39,370 \text{ inches/km}$

10. $\frac{108 \text{ miles}}{1 \text{ hour}} (0.44704 \text{ meters/second}) \approx 48.28 \text{ meters/second}$
 $48.28(45 \text{ seconds}) = 2,172.6 \text{ meters}$

11. The area of the rectangle, A , = 132 square centimeters and the length, l , = 11 centimeters. So,

$$132 = 11w$$

$$w = 12 \text{ centimeters}$$

The formula for the perimeter of a rectangle is $p = 2l + 2w$.

$$p = 2(11) + 2(12) = 22 + 24 = 46 \text{ centimeters}$$

12. $SA = 6x^2 = 6(1)^2 = 6$ square inches

13. $\frac{14 \div 7}{21 \div 7} = \frac{2}{3}$

14. $\frac{55 \div 11}{33 \div 11} = \frac{5}{3}$

15. $\frac{15a}{36} = \frac{45}{12}$
 $180a = 1620$
 $a = 9$

$$16. \frac{4x+5}{5} = \frac{2x+7}{7}$$
$$28x + 35 = 10x + 35$$
$$18x = 0$$
$$x = 0$$

$$17. 4(x-7) + x = 2$$
$$4x - 28 + x = 2$$
$$5x - 28 = 2$$
$$5x = 30$$
$$x = 6$$

$$18. x = 0.24(96) = 23.04$$

$$19. 4\frac{2}{5} - \left(-\frac{7}{3}\right) = \frac{22}{5} + \frac{7}{3} = \frac{22(3) + 7(5)}{15} = \frac{66 + 35}{15} = \frac{101}{15} \text{ OR } 6\frac{11}{15}$$

Lesson 3.9

$$\begin{aligned} 1. \quad a + 11.2 &= 7.3 \\ -11.2 \quad -11.2 \\ a &= -3.9 \end{aligned}$$

$$\begin{aligned} 2. \quad 9.045 + j &= 27 \\ -9.045 \quad -9.045 \\ j &= 17.955 \end{aligned}$$

$$\begin{aligned} 3. \quad 11 &= b + \frac{5}{7} \\ b &= 11 - \frac{5}{7} = \frac{11(7) - 5}{7} = \frac{77 - 5}{7} = \frac{72}{7} \text{ OR } 10\frac{2}{7} \end{aligned}$$

$$\begin{aligned} 4. \quad -22 &= -3 + k \\ +3 \quad +3 \\ k &= -19 \end{aligned}$$

$$\begin{aligned} 5. \quad -9 &= n - 6 \\ +6 \quad +6 \\ n &= -3 \end{aligned}$$

$$\begin{aligned} 6. \quad -6 + l &= -27 \\ +6 \quad +6 \\ l &= -21 \end{aligned}$$

$$\begin{aligned} 7. \quad \frac{s}{2} &= -18 \\ s &= -18(2) = -36 \end{aligned}$$

$$\begin{aligned} 8. \quad 29 &= \frac{e}{27} \\ e &= 29(27) = 783 \end{aligned}$$

$$\begin{aligned} 9. \quad u \div -66 &= 11 \\ u &= 11(-66) = -726 \end{aligned}$$

$$\begin{aligned} 10. \quad -5f &= -110 \\ f &= -110(-5) = 550 \end{aligned}$$

$$\begin{aligned} 11. \quad 76 &= -19p \\ p &= 76(-19) = -1,444 \end{aligned}$$

$$\begin{aligned} 12. \quad -h &= -9 \\ h &= -9(-1) = 9 \end{aligned}$$

$$13. \frac{q+1}{11} = -2$$
$$(11) \frac{q+1}{11} = -2(11)$$
$$q + 1 = -22$$
$$q = -22 - 1 = -23$$

$$14. -2 - 2m = -22$$
$$-2m = -20$$
$$m = 10$$

$$15. -5 + \frac{d}{6} = -7$$
$$\frac{d}{6} = -2$$
$$d = -2(6) = -12$$

$$16. 32 = 2b - 3b + 5b$$
$$32 = 4b$$
$$b = 8$$

$$17. 9 = 4h + 14h$$
$$9 = 18h$$
$$h = \frac{9}{18} = \frac{1}{2}$$

$$18. u - 3u - 2u = 144$$
$$-4u = 144$$
$$u = -36$$

$$19. 2i + 5 - 7i = 15$$
$$-5i + 5 = 15$$
$$-5i = 10$$
$$i = -2$$

$$20. -10 = t + 15 - 4t$$
$$-10 = -3t + 15$$
$$-25 = -3t$$
$$t = \frac{25}{3} \text{ OR } 8\frac{1}{3}$$

$$21. \frac{1}{2}k - 16 + 2\frac{1}{2}k = 0$$

$$3k = 16$$

$$k = \frac{16}{3} \text{ OR } 5\frac{1}{3}$$

$$22. \frac{-1543}{120} = \frac{3}{5}x + \frac{11}{4}\left(-\frac{11}{5}x + \frac{8}{5}\right)$$

$$\frac{-1543}{120} = \frac{3}{5}x - \frac{121}{20}x + \frac{88}{20}$$

$$\frac{-1543}{120} = \frac{12-121}{20}x + \frac{88}{20}$$

$$120\left(\frac{-1543}{120}\right) = \left(-\frac{109}{20}x + \frac{88}{20}\right)120$$

$$-1543 = -654x + 528$$

$$-2071 = -654x$$

$$x = \frac{-2071}{-654} = 3\frac{109}{654}$$

$$23. -5.44x + 5.11(7.3x + 2) = -37.3997 + 6.8x$$

$$-5.44x + 37.303 + 10.22 = 37.3997 + 6.8x$$

$$-5.44x + 47.505 = 37.3997 + 6.8x$$

$$10.1053 = 12.24x$$

$$x \approx 0.8256$$

$$24. -5(5r + 7) = 25 + 5r$$

$$-25r - 35 = 25 + 5r$$

$$-60 = 30r$$

$$r = -2$$

$$25. -7p + 37 = 2(-6p + 1)$$

$$-7p + 37 = -12p + 2$$

$$5p = -35$$

$$p = -7$$

$$26. 3(-5y - 4) = -6y - 39$$

$$-15y - 12 = -6y - 39$$

$$27 = 9y$$

$$y = 3$$

$$\begin{aligned}
27. \quad & 5(a - 7) + 2(a - 3(a - 5)) = 0 \\
& 5a - 35 + 2(a - 3a + 15) = 0 \\
& 5a - 35 + 2(-2a + 15) = 0 \\
& 5a - 35 - 4a + 30 = 0 \\
& a - 5 = 0 \\
& a = 5
\end{aligned}$$

$$28. \text{ 10 boys to 25 students} = \frac{10}{25} = \frac{2}{5}$$

$$29. \text{ 96 apples to 42 pears} = \frac{96}{42} = \frac{48}{21}$$

$$30. \text{ \$600 to \$900} = \frac{600}{900} = \frac{2}{3}$$

$$31. \text{ 45 miles to 3 hours} = \frac{45}{3} = 15 \text{ mph}$$

$$32. \text{ \$4.99 for 16 ounces of turkey burger} = \frac{\$4.99}{16 \text{ oz}} = \$0.31/\text{oz}$$

$$33. \text{ 40 computers to 460 students} = \frac{40}{460} \approx 0.0870 \text{ computers/student}$$

$$34. \text{ 18 teachers to 98 students} = \frac{18}{98} \approx 0.1827 \text{ teachers/student}$$

$$35. \text{ 48 minutes to 15 appointments} = \frac{48}{15} = 3.2 \text{ minutes/appointment}$$

$$\begin{aligned}
36. \quad & -\frac{6}{n-7} = -\frac{2}{n+1} \\
& \frac{6}{n-7} = \frac{2}{n+1} \\
& 6n + 6 = 2n - 14 \\
& 4n = -20 \\
& n = -5
\end{aligned}$$

$$\begin{aligned}
37. \quad &-\frac{9}{5} = \frac{x-7}{x+10} \\
&5(x-7) = -9(x+10) \\
&5x-35 = -9x-90 \\
&14x = -55 \\
&x = -\frac{55}{14} \text{ OR } -3\frac{13}{14}
\end{aligned}$$

$$\begin{aligned}
38. \quad &\frac{5b}{12} = \frac{3}{11} \\
&55b = 36 \\
&b = \frac{36}{55}
\end{aligned}$$

$$\begin{aligned}
39. \quad &-\frac{12}{n} = \frac{5}{2n+6} \\
&-12(2n+6) = 5n \\
&-24n-72 = 5n \\
&-72 = 19n \\
&n = -\frac{72}{19} \text{ OR } -3\frac{15}{19}
\end{aligned}$$

$$40. 0.4567(100\%) = 45.67\%$$

$$41. 2.01(100\%) = 201\%$$

$$42. 0.005(100\%) = 0.5\%$$

$$43. 0.043(100\%) = 4.3\%$$

$$44. 23.5 \div 100 = 0.235$$

$$45. 0.08 \div 100 = 0.0008$$

$$46. 0.025 \div 100 = 0.00025$$

$$47. 125.4 \div 100 = 1.254$$

$$48. 78\% = \frac{78}{100} = \frac{39}{50}$$

$$49. 11.2\% = \frac{112}{1000} = \frac{14}{125}$$

$$50. 10.5\% = \frac{105}{1000} = \frac{21}{200}$$

$$51. 33.\bar{3}\% = \frac{333}{1000}$$

$$52. 32.4 = 0.45x$$
$$x = \frac{32.4}{0.45} = 72$$

$$53. 58.7 = 1000x$$
$$x = \frac{58.7}{1000} = 0.0587(100\%) = 5.87\%$$

$$54. x = (0.12)78 = 9.36$$

55. The markup price is 100% of the original price plus 20%, or 120% = 1.2.
So, the markup price = $44(1.2) = \$52.80$

56. The new price is 100% - 15% = 85% of the original price.
So, sale price = $240(0.85) = \$204$

57. The difference in price is $89.99 - 74.99 = \$15.00$.
The percent markdown = $\frac{\text{amt of change}}{\text{original price}} = \frac{15.00}{89.99} = 0.1667(100\%) = 16.67\%$

58. percent markup = $\frac{\text{amt of change}}{\text{original price}} = \frac{4}{10} = 0.4(100\%) = 40\%$

59. c = the original price of the item

$$\frac{\text{amt of change}}{\text{original price}} = \frac{48}{c} = 0.3$$

$$c = \frac{48}{0.3} = 160$$

The original price of the item was \$160.

60. Let l = the length of the object.

The width (w) = $l - 15$, so the perimeter = $2l + 2w = 2l + 2(l - 15)$

$$98 = 2l + 2l - 30$$

$$98 = 4l - 30$$

$$68 = 4l$$

$$l = 17 \text{ units}$$

The length of the object is 17 units.

61. Let m = the number of miles.

$$\text{Then } 16.75 = 4 + 0.25m$$

$$12.75 = 0.25m$$

$$51 = m$$

He traveled 51 miles.

62. Let n = the number.

$$2n + 38 = 124$$

$$2n = 86$$

$$n = 43$$

63. Since all the sides of a square are the same, let s = the length of one side.

$$4s = 260$$

$$s = 65 \text{ yards}$$

64. Since $\frac{1}{8}$ of the pie costs \$3.79, then the entire pie costs $3.79(8) = \$30.32$.

65. The time the bulb was left on = $\frac{5.56}{0.06} \approx 92.67$ hours.

$$66. \frac{\text{height}}{\text{shadow}} = \frac{\text{height}}{\text{shadow}}$$

$$\frac{6\frac{1}{2}}{33.2} = \frac{\text{elephant}}{51.5}$$

$$\text{So, elephant}(33.2) = 334.75$$

$$\text{elephant} = 10.08 \text{ feet}$$

The elephant is 10.08 feet.

$$67. \frac{5 \text{ inches}}{32 \text{ miles}} = \frac{x \text{ inches}}{87 \text{ miles}}$$

$$32x = 435$$

$$x = 13.59$$

The map would show the cities 13.59 inches apart.

3.10 Chapter Test

1. amt of change = $2.35 - 1.60 = 0.75$

$$\frac{\text{amt of change}}{\text{original price}} = \frac{0.75}{1.60} = 0.48875(100\%) = 48.875\%$$

2. $\frac{3c}{8} = 11$

$$3c = 88$$

$$c = 29.333\dots$$

3. $6.35(100\%) = 635\%$

4. $\frac{85}{6}$

5. Let x = the number of cupcakes made on the second day. Then

$$(x - 12) + x = 68$$

$$2x - 12 = 68$$

$$2x = 80$$

$$x = 40$$

She made 40 cupcakes on the second day.

6. $\frac{\text{height}}{\text{shadow}} = \frac{\text{height}}{\text{shadow}}$

$$\frac{8}{4} = \frac{4}{x}$$

$$8x = 16$$

$$x = 2$$

The shadow is 2 feet long.

7. $\frac{v}{v-2} = -\frac{9}{5}$

$$-9(v-2) = 5v$$

$$-9v + 18 = 5v$$

$$18 = 14v$$

$$v = \frac{18}{14} = \frac{9}{7}$$

$$8. \frac{21 \text{ km}}{4 \text{ cm}} = \frac{x \text{ km}}{16 \text{ cm}}$$

$$4x = 336$$

$$x = 84$$

Owosso and Perry are 84 km apart.

$$9. -\frac{13}{4} - \frac{3}{2} \left(\frac{3}{4}j - \frac{4}{5} \right) = -\frac{14}{5}$$

$$-\frac{13}{4} - \frac{6}{8}j + \frac{8}{10} = -\frac{14}{5}$$

$$-\frac{6}{8}j + \frac{-13(5) + 8(2)}{20} = -\frac{14}{5}$$

$$-\frac{3}{4}j - \frac{49}{20} = -\frac{14}{5}$$

$$-\frac{3}{4}j = -\frac{14}{5} + \frac{49}{20} = \frac{-14(4) + 49}{20} = -\frac{7}{20}$$

$$-\frac{3}{4}j = -\frac{7}{20}$$

$$j = -\frac{7}{20} \left(-\frac{4}{3} \right) = \frac{7}{15}$$

$$10. 2m(2 - 4) + 5m(-8) = 9$$

$$4m - 8 - 40m = 9$$

$$-36m - 8 = 9$$

$$-36m = 17$$

$$m = -\frac{17}{36}$$

11. Let h = the number of hours.

$$15 + 2h = 3.75h$$

$$15 = 1.75h$$

$$h = 8.57$$

Job A and Job B will pay the same at 8.57 hours worked.

$$12. 9.0604 + 2.062k = 0.3(2.2k + 5.9)$$

$$9.0604 + 2.062k = 0.66k + 1.77$$

$$9.0604 + 1.402k = 1.77$$

$$1.402k = -7.2904$$

$$k = -5.2$$

13. $-9 - a = 15$

$$-a = 24$$

$$a = -24$$

14. $46 = 0.11x$

$$x = \frac{46}{0.11} = 418.18 \text{ tons}$$

15. $0.17x = 473$

$$x = \frac{473}{0.17} \approx 2,782.35 \text{ meters}$$

16. The amount of change = $309 - 73 = 236$

$$\frac{\text{amt of change}}{\text{original price}} = \frac{236}{73} \approx 3.23(100\%) = 323\%$$

17. $3\left(4\frac{1}{3}\right) = 3\left(\frac{13}{3}\right) = 13$ cups of flour

18. The amount of change = $80 - 45 = 35$

$$\frac{\text{amt of change}}{\text{original price}} = \frac{35}{80} = 0.4375(100\%) = 43.75\%$$

Chapter 4 Graphing Linear Equations and Functions

Lesson 4.1

1. $(-2, -2)$
2. $(5, 6)$
3. $(2, -6)$
4. $(3, -4)$
5. $(-5, 5)$
6. $(-2, 3)$
7. -14 .

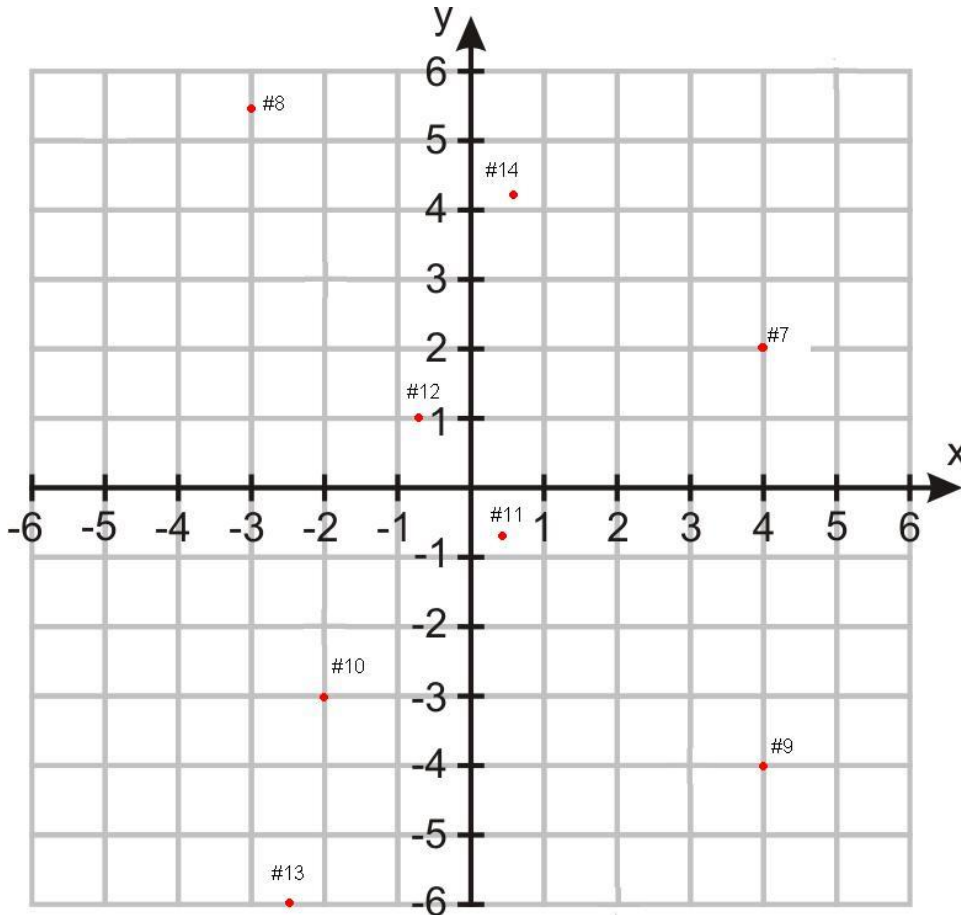

15. – 22.

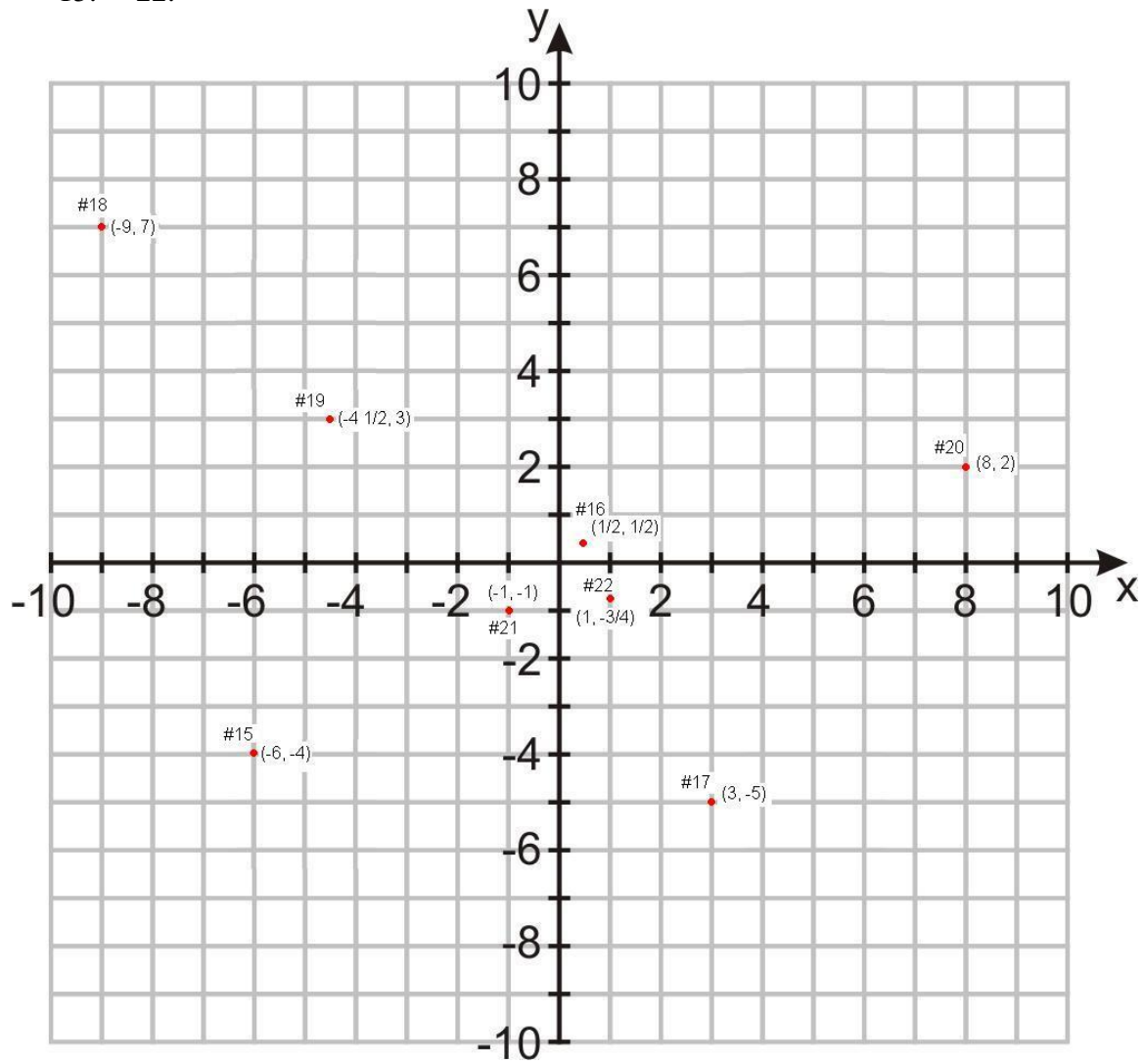

23.

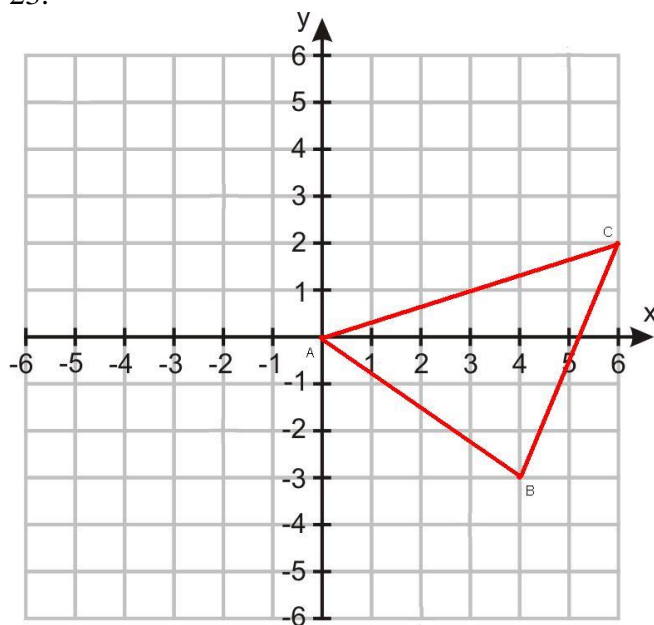

24.

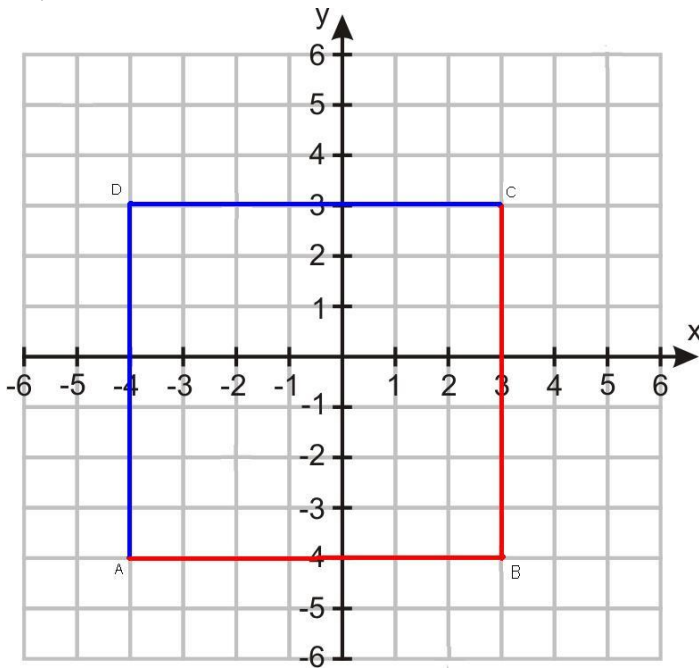

25. The point $(2, 0)$ does not lie in a quadrant. Since the y -coordinate is 0, then the point lies on the x -axis.

26. The point $(0, 0)$ is called the origin because it is the beginning location for counting the distance right or left and the distance up or down.

27. (a) $y = 3x$
(b)

x	$y = 3x$	y
0	$y = 3(0) = 0$	0
1	$y = 3(1) = 3$	3
2	$y = 3(2) = 6$	6
3	$y = 3(3) = 9$	9
4	$y = 3(4) = 12$	12
5	$y = 3(5) = 15$	15

(c)

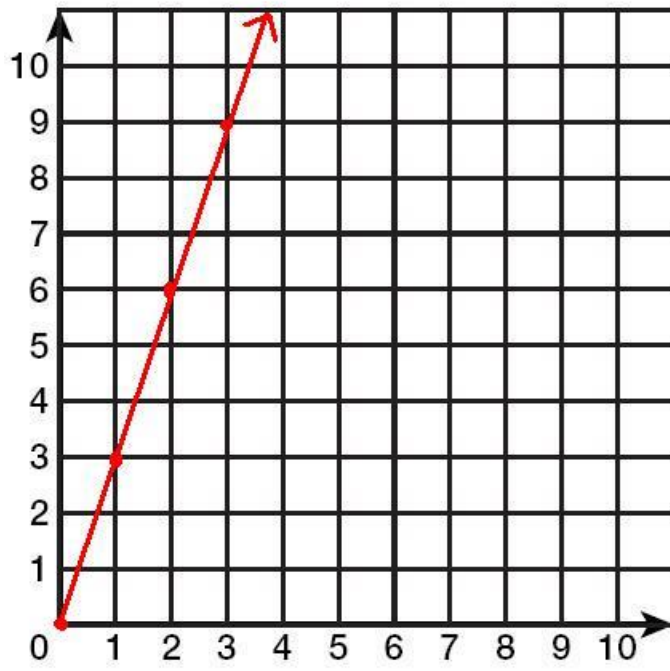

28.

x	$y = \frac{1}{4}x + 8$	y
-8	$y = \frac{1}{4}(-8) + 8 = -2 + 8 = 6$	6
-4	$y = \frac{1}{4}(-4) + 8 = -1 + 8 = 7$	7
0	$y = \frac{1}{4}(0) + 8 = 0 + 8 = 8$	8
4	$y = \frac{1}{4}(4) + 8 = 1 + 8 = 9$	9
8	$y = \frac{1}{4}(8) + 8 = 2 + 8 = 10$	10

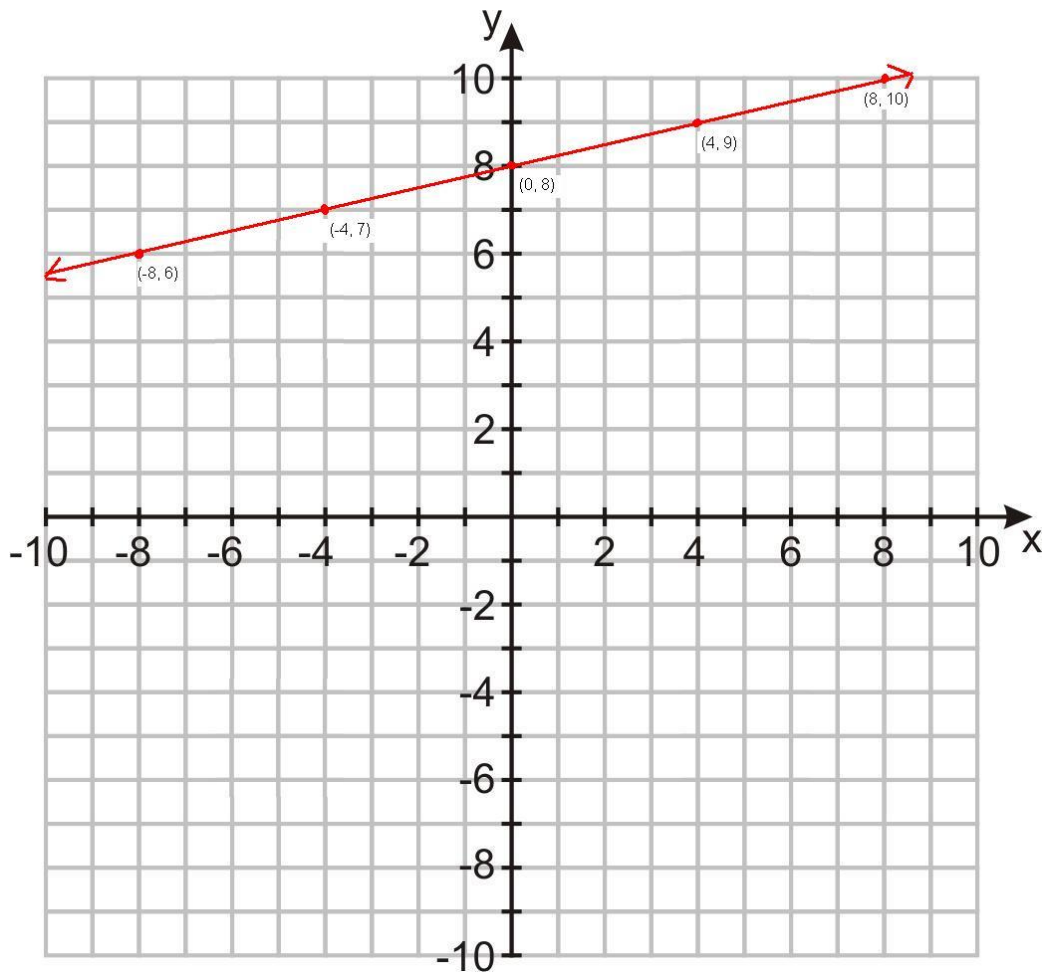

29.

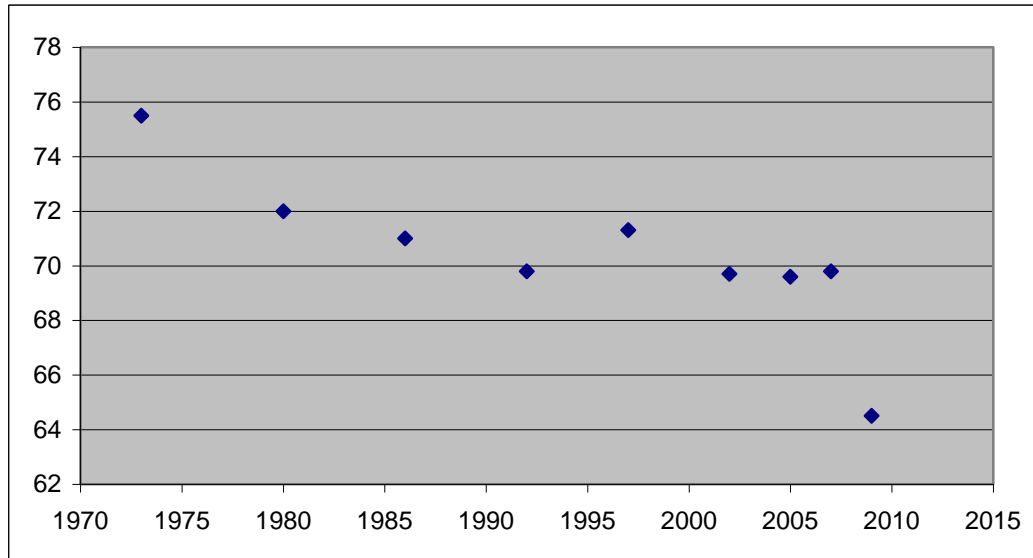

The percent of the men employed in the U.S. will continue to decline in the near future.

$$30. \frac{3}{8} + \frac{1}{5} - \frac{5}{9} = \frac{3(45) + 1(72) - 5(40)}{360} = \frac{135 + 72 - 200}{360} = \frac{7}{360}$$

$$31. \begin{aligned} 0.05m + 0.025(6000 - m) &= 512 \\ 0.05m + 150 - 0.025m &= 512 \\ 0.025m + 150 &= 512 \\ 0.025m &= 362 \\ m &= \frac{362}{0.025} = 14,480 \end{aligned}$$

$$32. \begin{aligned} \frac{16}{u-8} &= \frac{36}{u} \\ 16u &= 36(u-8) \\ 16u &= 36u - 288 \\ -20u &= -288 \\ u &= \frac{-288}{-20} = 14\frac{2}{5} \end{aligned}$$

33. The Additive Identity Property allows one to add 0 to an equation and not change to value of the variable.

$$34. \frac{28}{4} - 3 = 7 - 3 = 4 \text{ apples}$$

$$35. \begin{aligned} P &= a + b + c. \text{ We know } P = 34, a = 12, \text{ and } b = 7. \\ 34 &= 12 + 7 + c \\ 34 &= 19 + c \\ c &= 34 - 19 = 15 \end{aligned}$$

$$36. \frac{y^2 - 16 + 10y + 2x}{2} \text{ when } x = 2 \text{ and } y = -2$$
$$\frac{(-2)^2 - 16 + 10(-2) + 2(2)}{2} = \frac{4 - 16 - 20 + 4}{2} = \frac{-28}{2} = -14$$

Lesson 4.2

1. The solutions to an equation with two variables are ordered pairs that can be graphed on a Cartesian plane. Solutions to an equation with one variable can be graphed on a number line.
2. The equation for the x -axis is $y = 0$.
3. The equation for the y -axis is $x = 0$.
4. Based on the tax graph, and item that costs \$8.00 before taxes will cost a total of \$9.00 after taxes.
5. Based on the temperature graph:
 - a. 32°F
 - b. About 85°F
 - c. -17°C
 - d. Students cannot answer this question based on what they have been taught so far. They cannot extrapolate until Chapter 5.**
6. a.

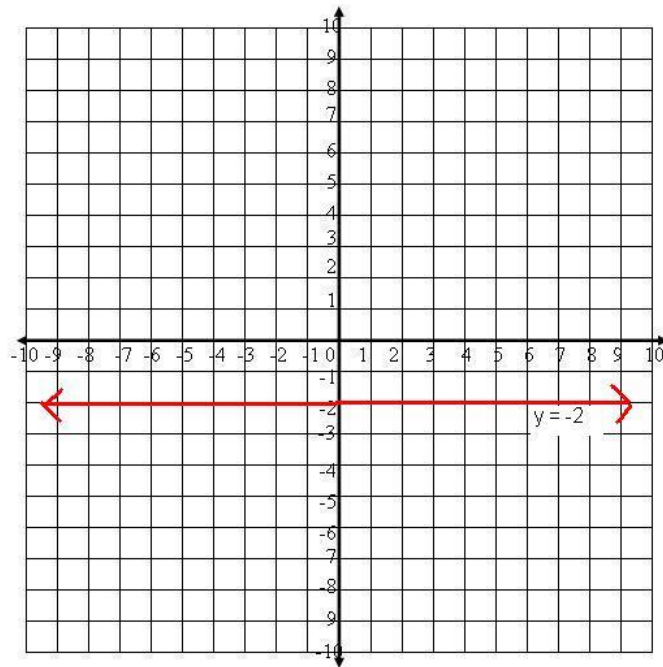

b.

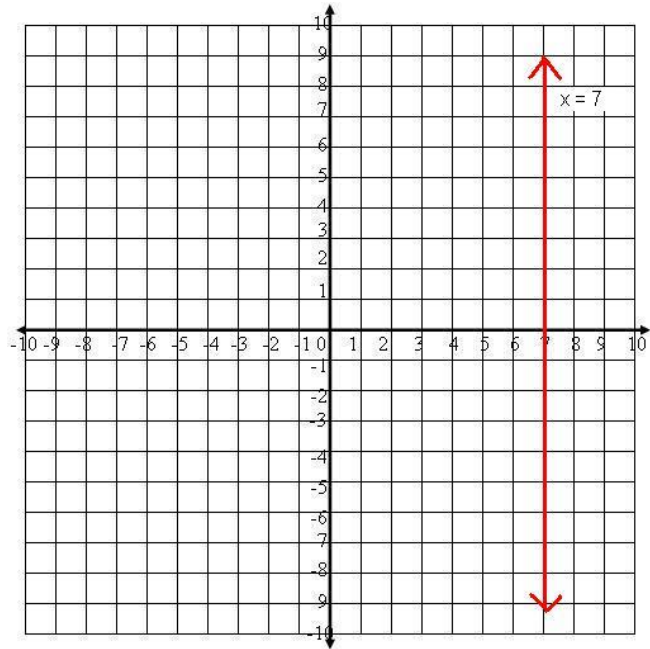

c.

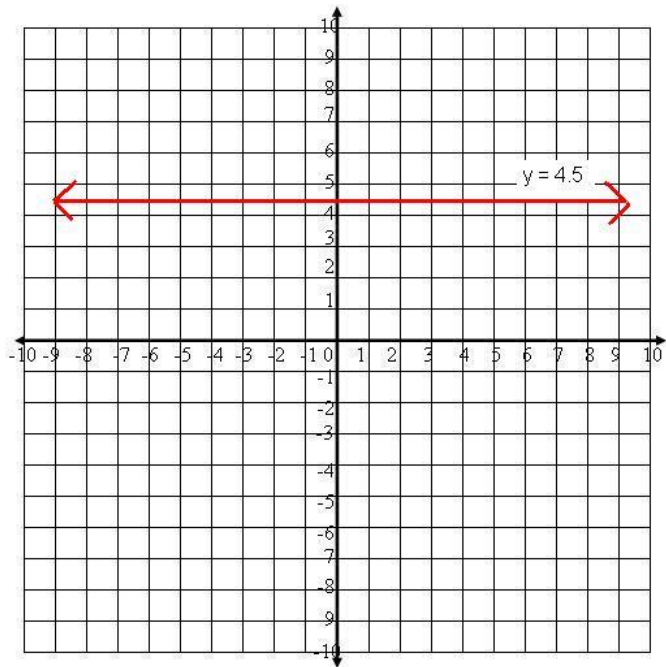

d.

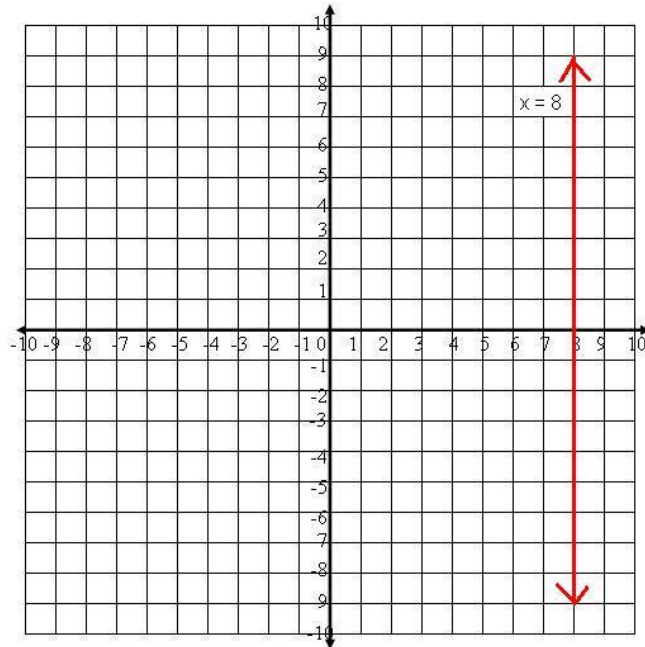

7. Four kilograms is approximately nine pounds.
8. Nine kilograms is approximately twenty pounds.
9. Twelve pounds is approximately 5.4 kilograms.
10. Seventeen pounds is approximately 7.5 kilograms.
11. The equation for line E is $x = 6$.
12. The equation for line B is $y = -2$.
13. The equation for line C is $y = -7$.
14. The equation for line A is $y = 5$.
15. The equation for line D is $x = -4$.

16. Let x = the amount of dollars. Then $f(x)$ = the amount of Euros.

x	$f(x)$
6	0.7
11	4.2
16	7.7
30	17.5
60	38.5

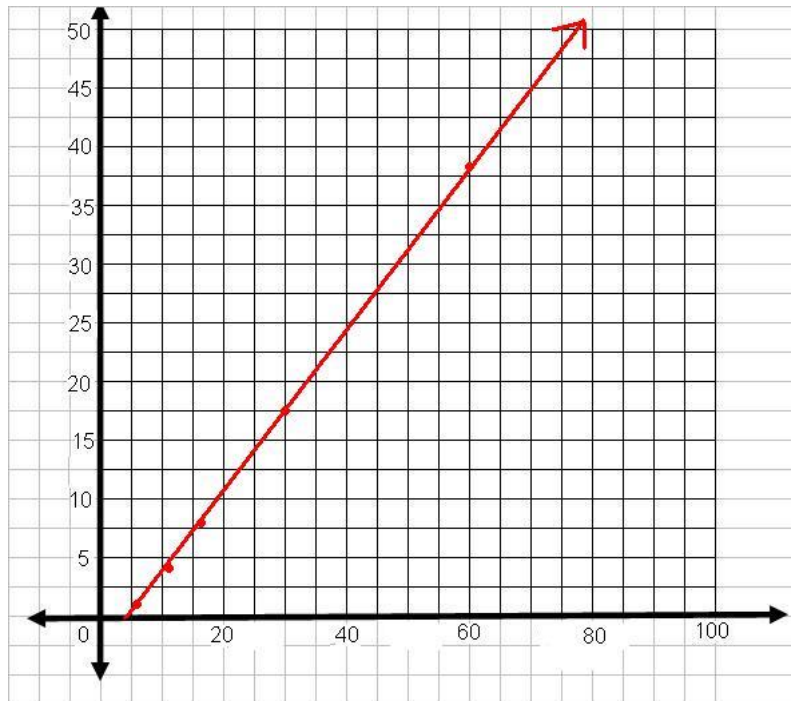

The number of Euros one would receive for \$50 is about 31.5 Euros.

17. Let x = the number.

x	$f(x) = 3x - 7$	$f(x)$
1	$f(1) = 3(1) - 7 = -4$	-4
2	$f(2) = 3(2) - 7 = -1$	-1
3	$f(3) = 3(3) - 7 = 2$	2
4	$f(4) = 3(4) - 7 = 5$	5
5	$f(5) = 3(5) - 7 = 8$	8

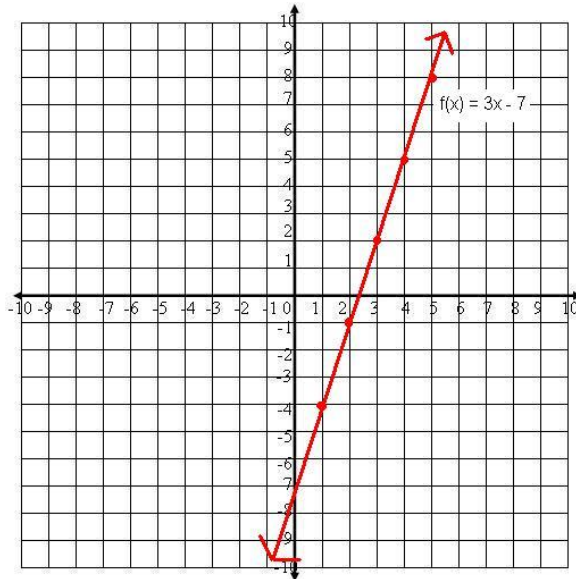

18.

x	$y = 2x + 7$	y
-3	$y = 2(-3) + 7 = 1$	1
-2	$y = 2(-2) + 7 = 3$	3
-1	$y = 2(-1) + 7 = 5$	5
0	$y = 2(0) + 7 = 7$	7
1	$y = 2(1) + 7 = 9$	9

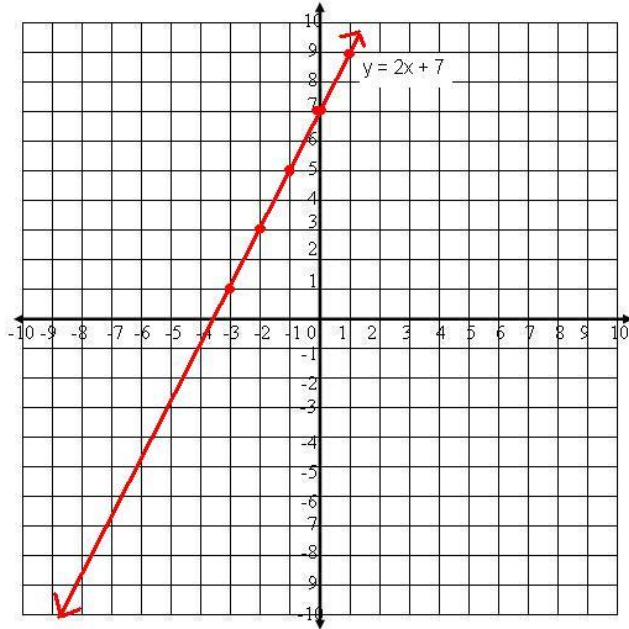

19.

x	$y = 0.7x - 4$	y
0	$y = 0.7(0) - 4 = -4$	-4
1	$y = 0.7(1) - 4 = -3.3$	-3.3
3	$y = 0.7(3) - 4 = -1.9$	-1.9
5	$y = 0.7(5) - 4 = -0.5$	-0.5
7	$y = 0.7(7) - 4 = 0.9$	0.9

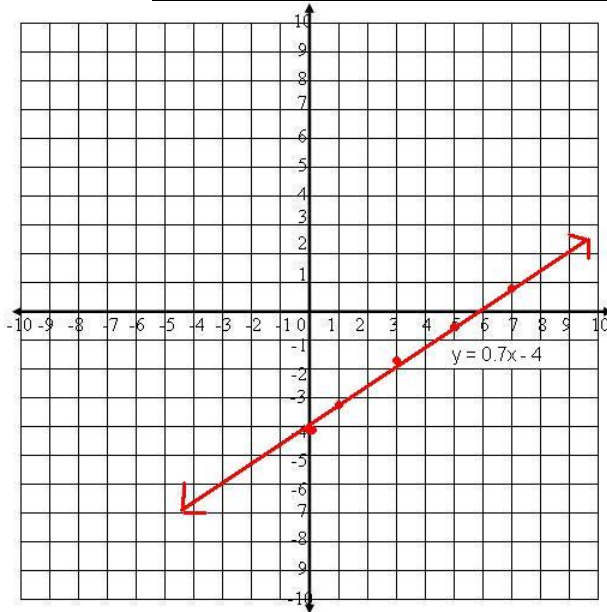

20.

x	$y = 6 - 1.25x$	y
-1	$y = 6 - 1.25(-1) = 7.25$	7.25
0	$y = 6 - 1.25(0) = 6$	6
1	$y = 6 - 1.25(1) = 4.75$	4.75
2	$y = 6 - 1.25(2) = 3.5$	3.5
4	$y = 6 - 1.25(4) = 1$	1

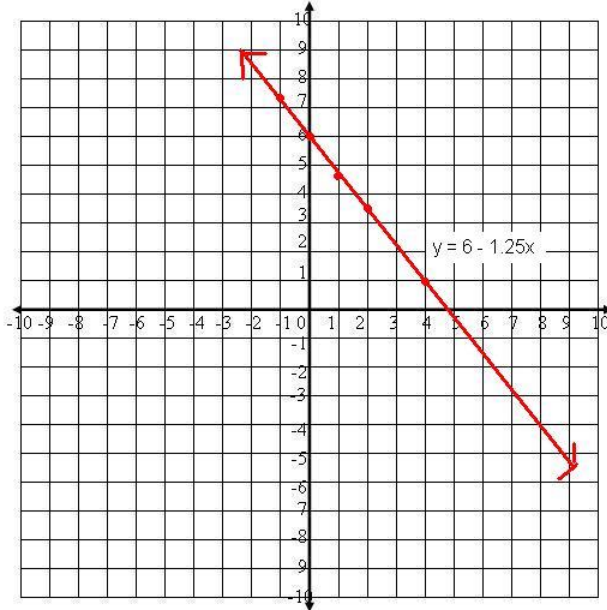

21. The amount of change = $19.50 - 17 = 2.50$.

$$\text{percent change} = \frac{\text{amount of change}}{\text{original amount}} = \frac{2.50}{17} = 14.7\% \text{ increase}$$

22. One ordered pair in Quadrant III is $(-7, -2)$.

$$23. \frac{1}{3} \left(\frac{1}{2} \right) = \frac{1}{6}$$

$$24. b + 16 = 3b - 2$$

$$16 - 2 = 3b - b$$

$$14 = 2b$$

$$b = 7$$

25. What is 16% of 97?

$$x = 0.16(97) = 15.52$$

$$26. 0.73(80) = 58.4$$

Cheyenne got 58 questions correct.

27. Four math verbs any of the following – divide, subtract, add, multiply, square root, exponent – there are many others

Lesson 4.3

1. intercept – the point at which a graphed line crosses an axis
2. The coordinates for an x -intercept is $(x, 0)$, where x is any real number on the x -axis.
3. One can “Cover Up” one of the terms, which symbolizes eliminating one of the variables using the multiplication property of zero. Then one can solve the remaining equation for the other variable. This will provide the intercept. After, one can repeat the process with the other variable.

$$\begin{array}{ll} 4. & y = 3x - 6 \\ & 0 = 3x - 6 \\ & 6 = 3x \\ & x = 2 \\ & (2, 0) \end{array} \qquad \begin{array}{l} y = 3(0) - 6 \\ y = 0 - 6 \\ y = -6 \\ (0, -6) \end{array}$$

$$\begin{array}{ll} 5. & y = -2x + 4 \\ & 0 = -2x + 4 \\ & -4 = -2x \\ & x = 2 \\ & (2, 0) \end{array} \qquad \begin{array}{l} y = -2(0) + 4 \\ y = 0 + 4 \\ y = 4 \\ (0, 4) \end{array}$$

$$\begin{array}{ll} 6. & y = 14x - 21 \\ & 0 = 14x - 21 \\ & 21 = 14x \\ & x = \frac{3}{2} \\ & \left(\frac{3}{2}, 0\right) \end{array} \qquad \begin{array}{l} y = -2(0) - 21 \\ y = 0 - 21 \\ y = -21 \\ (0, -21) \end{array}$$

$$\begin{array}{ll} 7. & y = 7 - 3x \\ & 0 = 7 - 3x \\ & -7 = -3x \\ & x = \frac{7}{3} \\ & \left(\frac{7}{3}, 0\right) \end{array} \qquad \begin{array}{l} y = 7 - 3x \\ y = 7 - 0 \\ y = 7 \\ (0, 7) \end{array}$$

$$\begin{array}{ll} 8. & 5x - 6y = 15 \\ & 5x = 15 \\ & x = 3 \\ & (3, 0) \end{array} \qquad \begin{array}{l} 5x - 6y = 15 \\ -6y = 15 \\ y = \frac{15}{-6} = -\frac{5}{2} \\ (0, -\frac{5}{2}) \end{array}$$

$$\begin{array}{ll}
 9. \quad 3x - 4y = -5 & 3x - 4y = -5 \\
 \quad 3x = -5 & -4y = -5 \\
 \quad x = -\frac{5}{3} & y = \frac{5}{4} \\
 \quad \left(-\frac{5}{3}, 0\right) & \left(0, \frac{5}{4}\right)
 \end{array}$$

$$\begin{array}{ll}
 10. \quad 2x + 7y = -11 & 2x + 7y = -11 \\
 \quad 2x = -11 & 7y = -11 \\
 \quad x = -\frac{11}{2} & y = -\frac{11}{7} \\
 \quad \left(-\frac{11}{2}, 0\right) & \left(0, -\frac{11}{7}\right)
 \end{array}$$

$$\begin{array}{ll}
 11. \quad 5x + 10y = 25 & 5x + 10y = 25 \\
 \quad 5x = 25 & 10y = 25 \\
 \quad x = 5 & y = \frac{5}{2} \\
 \quad (5, 0) & \left(0, \frac{5}{2}\right)
 \end{array}$$

12. I prefer the cover-up method because it saves a step. **(OR other valid answer)**

$$\begin{array}{ll}
 13. \quad y = 2x + 3 & y = 2x + 3 \\
 \quad 0 = 2x + 3 & y = 3 \\
 \quad -3 = 2x & (0, 3) \\
 \quad x = -\frac{3}{2} & \\
 \quad \left(-\frac{3}{2}, 0\right) &
 \end{array}$$

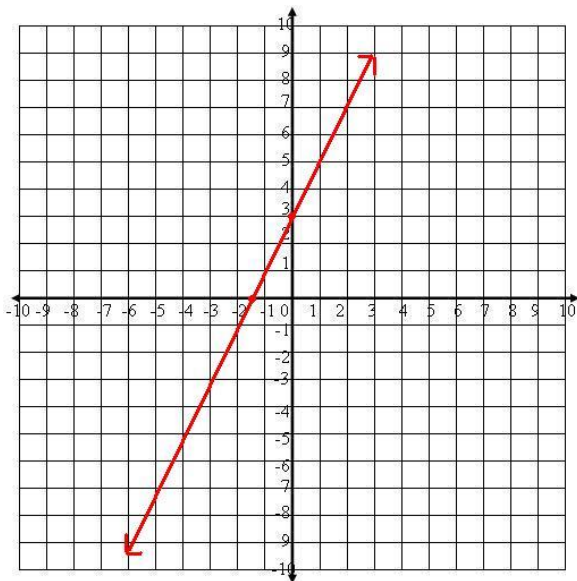

$$\begin{array}{ll}
 14. \quad 6(x - 1) = 2(y + 3) & 6(x - 1) = 2(y + 3) \\
 \quad 6x - 6 = 2y + 6 & 6x - 6 = 2y + 6 \\
 \quad 6x - 6 = 6 & -6 = 2y + 6 \\
 \quad 6x = 12 & -12 = 2y \\
 \quad (2, 0) & (0, -6)
 \end{array}$$

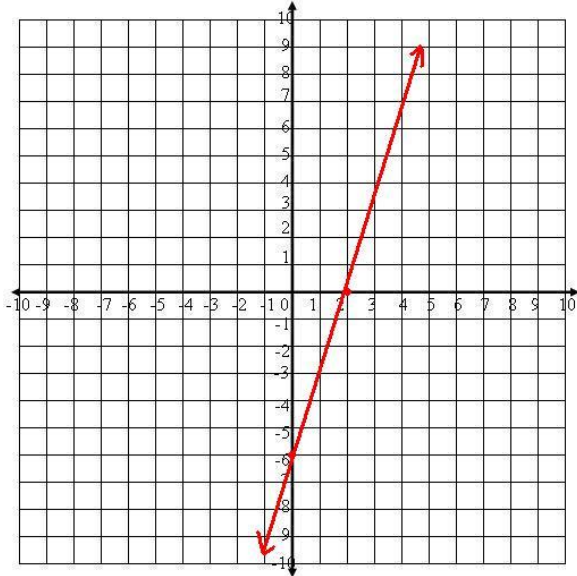

$$\begin{array}{ll}
 15. \quad x - y = 5 & x - y = 5 \\
 \quad x = 5 & -y = -5 \\
 \quad (5, 0) & (0, 5)
 \end{array}$$

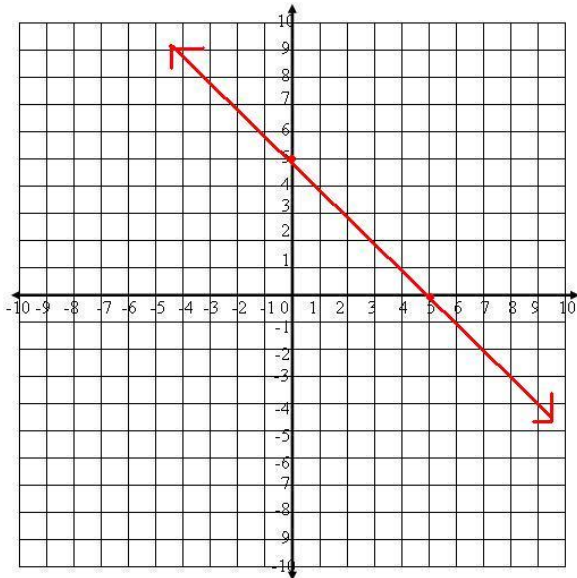

16. $x + y = 8$
 $x = 8$
 $(8, 0)$

$x + y = 8$
 $y = 8$
 $(0, 8)$

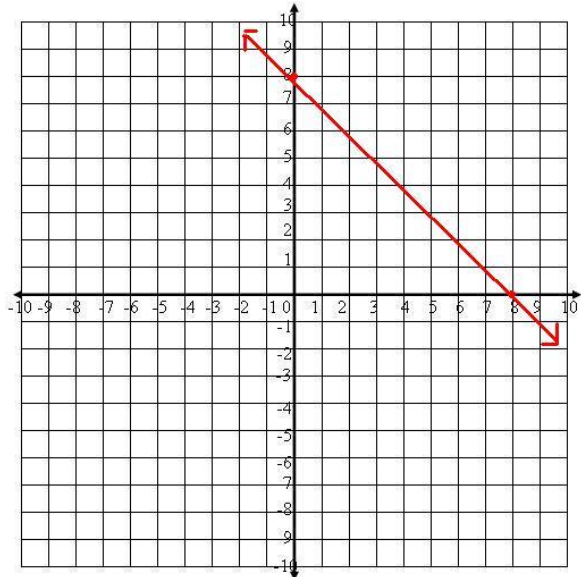

17. $4x + 9y = 0$
 $4x = 0$
 $x = 0$
 $(0, 0)$

Since the x -intercept is the origin, there is no need to find the y -intercept.

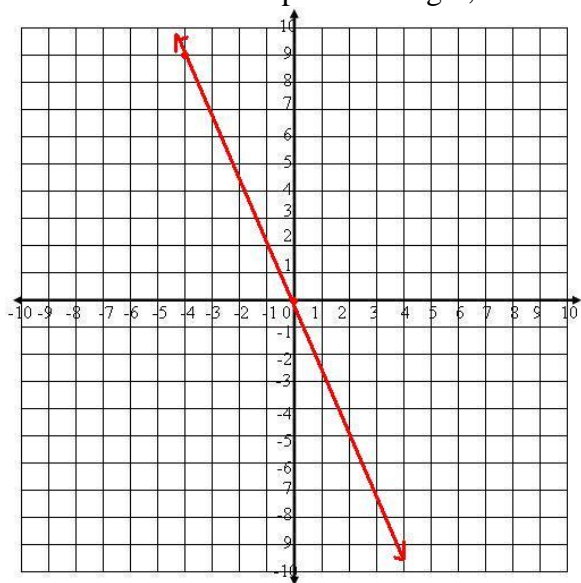

$$18. \frac{1}{2}x + 4y = 12$$

$$\frac{1}{2}x = 12$$

$$x = 24$$

$$(24, 0)$$

$$\frac{1}{2}x + 4y = 12$$

$$4y = 12$$

$$y = 3$$

$$(0, 3)$$

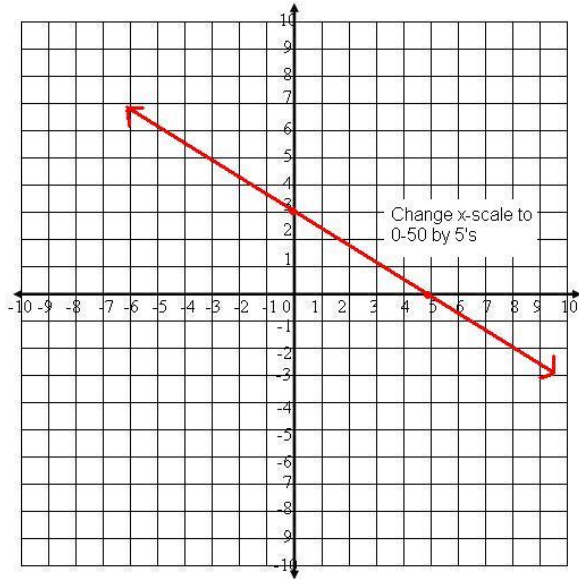

$$19. x - 2y = 4$$

$$x = 4$$

$$(4, 0)$$

$$x - 2y = 4$$

$$-2y = 4$$

$$(0, -2)$$

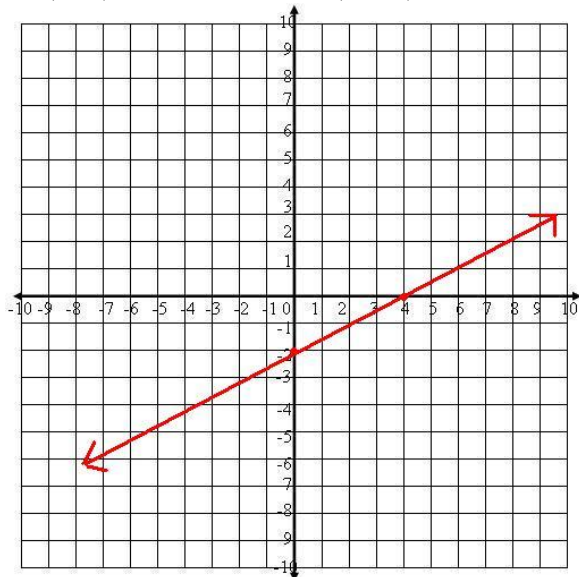

$$20. 7x - 5y = 10$$

$$7x = 10$$

$$x = \frac{10}{7}$$

$$\left(\frac{10}{7}, 0\right)$$

$$7x - 5y = 10$$

$$-5y = 10$$

$$y = -2$$

$$(0, -2)$$

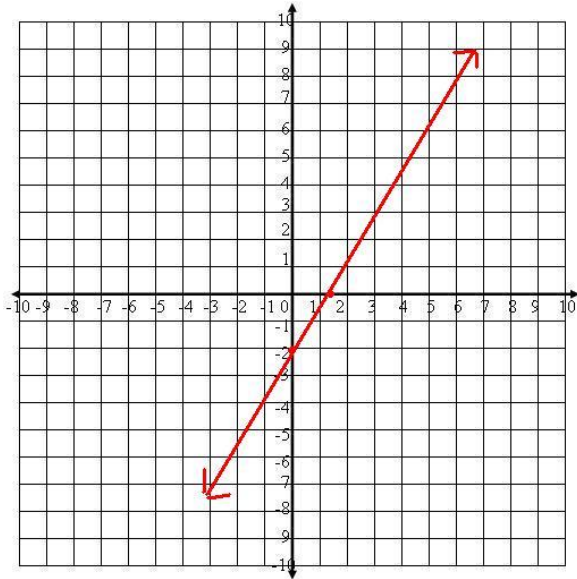

$$21. 4x - y = -3$$

$$4x = -3$$

$$x = -\frac{3}{4}$$

$$\left(-\frac{3}{4}, 0\right)$$

$$4x - y = -3$$

$$-y = -3$$

$$y = 3$$

$$(0, 3)$$

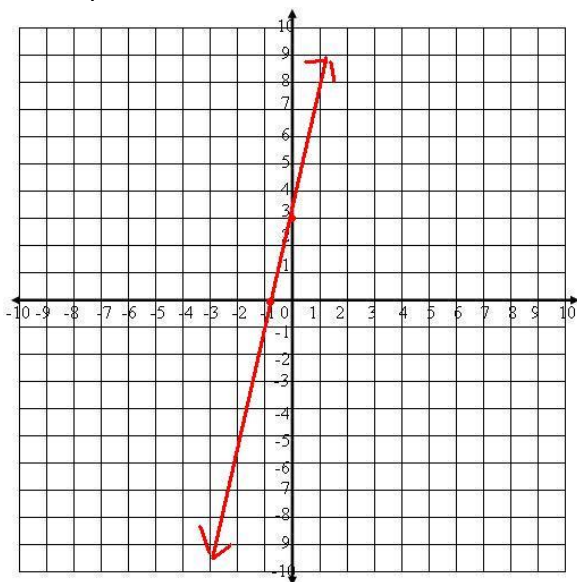

22. $x - y = 0$

$x = 0$

$(0, 0)$

Since the x -intercept is the origin, there is no need to find the y -intercept.

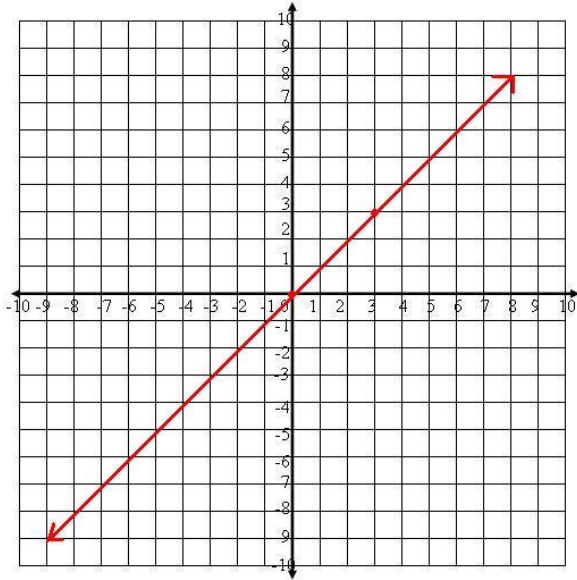

23. $5x + y = 5$

$5x = 5$

$x = 1$

$(1, 0)$

$5x + y = 5$

$y = 5$

$(0, 5)$

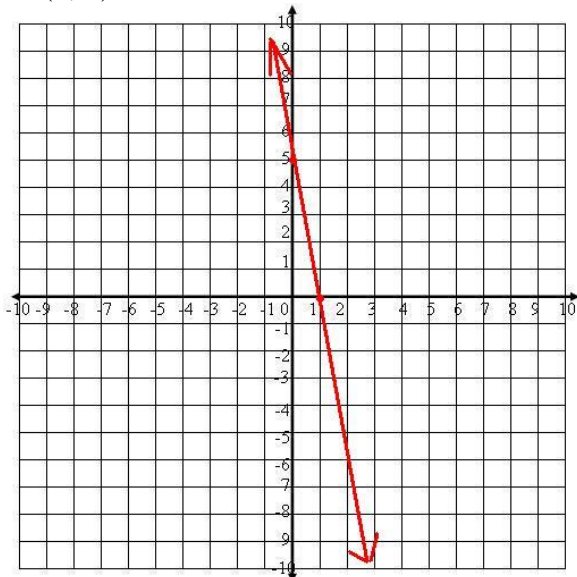

24. $7x - 2y = -6$

$$7x = -6$$

$$x = -\frac{6}{7}$$

$$\left(-\frac{6}{7}, 0\right)$$

$$7x - 2y = -6$$

$$-2y = -6$$

$$y = 3$$

$$(0, 3)$$

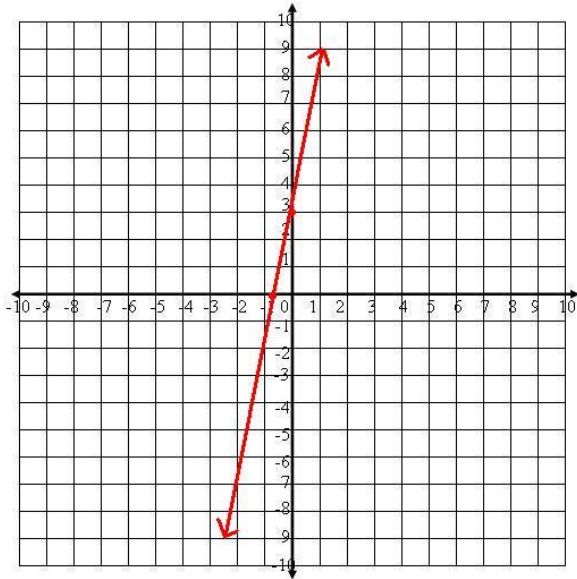

25. Vertical lines have x -intercepts only.

26. The line represented by $y = 5$ is a horizontal line. Therefore, it only has a y -intercept.

27. $x = -4$

28. There are an infinite number of lines that can be drawn with only $(0, 0)$ as the intercept. The slope is the only thing that will change.

29. One must distribute the 3 on the left side of the equation and distribute the 2 on the right side of the equation.

30. Let x = the number of pounds of strawberries and y = the number of pounds of bananas.
 Then we can write $3x + 1y = 10$ or $3x + y = 10$.
 $y = -3x + 10$

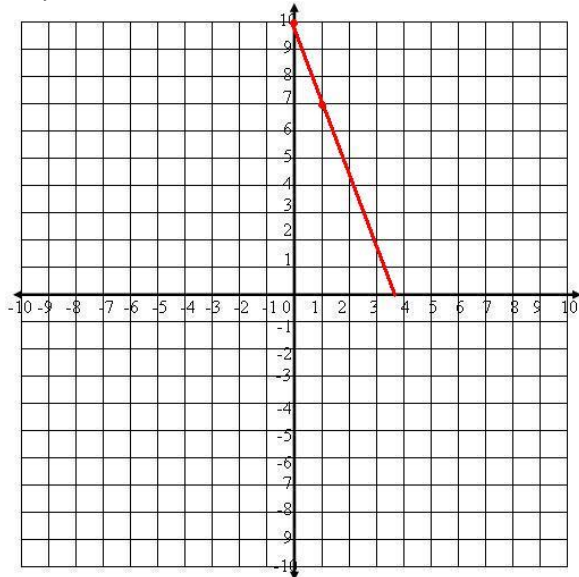

31. Let x = the number of adult tickets and y = the number of children's tickets. Then we can
 write $7.50x + 4.50y = 900$.
 $4.50y = -7.50x + 900$

$$y = -\frac{7.50}{4.50}x + \frac{900}{4.50}$$

$$y = -\frac{5}{3}x + 200$$

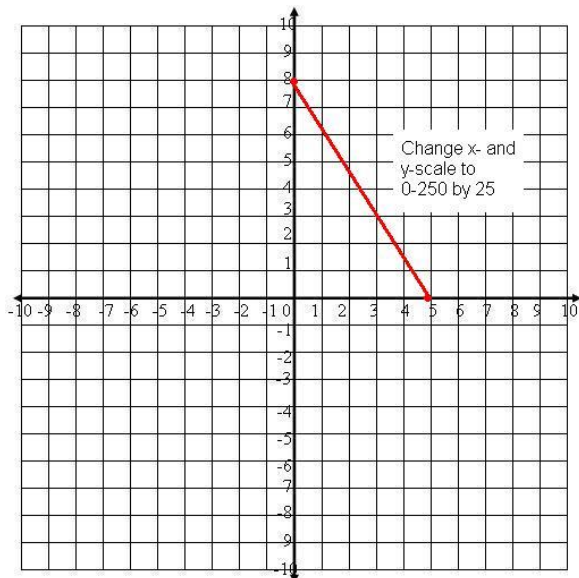

32. Let x = the number of touchdowns and y = the number of field goals. Then we can write

$$6x + 3y = 36.$$

$$3y = -6x + 36$$

$$y = -2x + 12$$

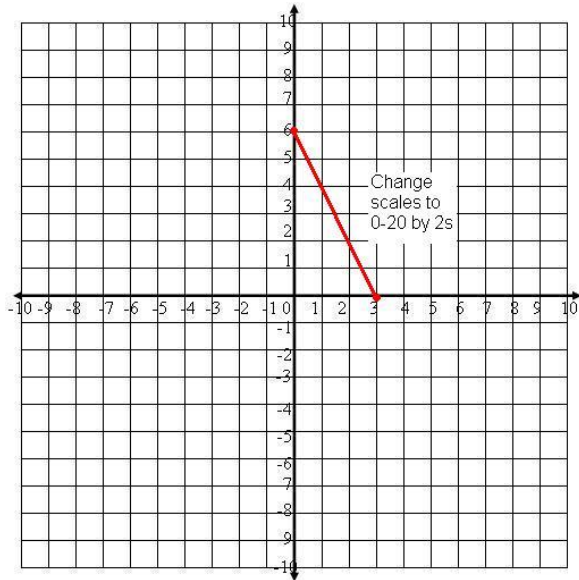

33. $5x + 2y = 23$; $(7, -6)$ and $(3, 4)$

$$5(7) + 2(-6) = 23$$

$$35 + (-12) = 23$$

$$23 = 23$$

$(7, -6)$ is a solution

$$5(3) + 2(4) = 23$$

$$15 + 8 = 23$$

$$23 = 23$$

$(3, 4)$ is a solution

34. $3a - 2b = 6$; $(0, 3)$ and $\left(\frac{5}{3}, \frac{-1}{2}\right)$

$$3(0) - 2(3) = 6$$

$$0 - 6 = 6$$

$$-6 \neq 6$$

$(0, 3)$ is not a solution

$$3\left(\frac{5}{3}\right) - 2\left(-\frac{1}{2}\right) = 6$$

$$5 + 1 = 6$$

$$6 = 6$$

$\left(\frac{5}{3}, \frac{-1}{2}\right)$ is a solution

35.

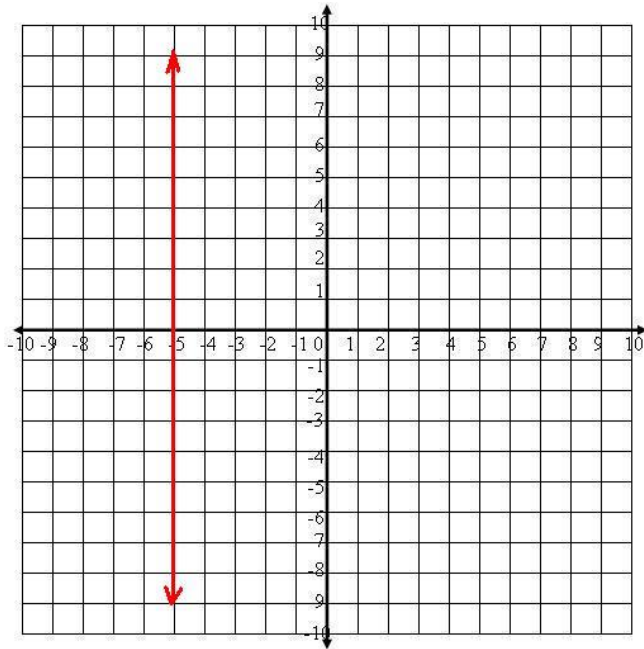

$$36. \frac{4}{5}k - 16 = -\frac{1}{4}$$

$$20\left(\frac{4}{5}k - 16\right) = 20\left(-\frac{1}{4}\right)$$

$$16k - 320 = 5$$

$$16k = 325$$

$$k = \frac{325}{16} = 20\frac{5}{16}$$

37. The relation is not a function because one value in the domain (0) is matched to two values in the range (0 and 6).

38. The domain would be whole numbers.

39. amount of change = $1299 - 1145 = 154$

$$\text{percent change} = \frac{\text{amount of change}}{\text{original amount}} = \frac{154}{1299} \approx 11.9\%$$

Lesson 4.4

1. Slope is the measure of steepness of a line. (page 137)
2. The rate of change of a real-life situation is the same as the slope. Slope can refer to hypothetical or non-real life scenarios.
3. You can use the slope formula or the slope triangle method. I prefer the slope formula because one can always calculate the slope of a line in he/she knows two points on the line. **(or other valid answer)**
4. All vertical lines have an undefined slope because the denominator results in 0. Division by 0 is undefined.
5. All horizontal lines have zero slope because the numerator results in 0.

6. (a) Two points on the line are (3, 6) and (-1, -6)

$$m = \frac{y_2 - y_1}{x_2 - x_1} = \frac{6 - (-6)}{3 - (-1)} = \frac{12}{4} = 3$$

- (b) Two points on the line are (0, 1) and (-6, -2)

$$m = \frac{y_2 - y_1}{x_2 - x_1} = \frac{-2 - 1}{-6 - 0} = \frac{-3}{-6} = \frac{1}{2}$$

7. (c) Two points on the line are (-1, 6) and (-5, -6)

$$m = \frac{y_2 - y_1}{x_2 - x_1} = \frac{-6 - 6}{-5 - (-1)} = \frac{-12}{-4} = 3$$

- (d) Two points on the line are (4, 2) and (-2, -4)

$$m = \frac{y_2 - y_1}{x_2 - x_1} = \frac{-4 - 2}{-2 - 4} = \frac{-6}{-6} = 1$$

8. (d) Two points on the line are (4, 2) and (4, -6)

$$m = \frac{y_2 - y_1}{x_2 - x_1} = \frac{-6 - 2}{4 - 4} = \frac{-8}{0} = \text{undefined}$$

Vertical lines have undefined slope.

- (f) Two points on the line are (3, 1) and (-6, -2)

$$m = \frac{y_2 - y_1}{x_2 - x_1} = \frac{-2 - 1}{-6 - 3} = \frac{-3}{-9} = \frac{1}{3}$$

9. $m = \frac{y_2 - y_1}{x_2 - x_1} = \frac{0 - 7}{0 - (-5)} = \frac{-7}{5} = -\frac{7}{5}$

10. $m = \frac{y_2 - y_1}{x_2 - x_1} = \frac{11 - (-5)}{3 - (-3)} = \frac{16}{6} = \frac{8}{3}$

$$11. m = \frac{y_2 - y_1}{x_2 - x_1} = \frac{9 - (-5)}{-2 - 3} = \frac{14}{-5} = -\frac{14}{5}$$

$$12. m = \frac{y_2 - y_1}{x_2 - x_1} = \frac{11 - 7}{-5 - (-5)} = \frac{4}{0} = \text{undefined}$$

$$13. m = \frac{y_2 - y_1}{x_2 - x_1} = \frac{-9 - 9}{-9 - 9} = \frac{-18}{-18} = 1$$

$$14. m = \frac{y_2 - y_1}{x_2 - x_1} = \frac{7 - 5}{-2 - 3} = \frac{2}{-5} = -\frac{2}{5}$$

$$15. m = \frac{y_2 - y_1}{x_2 - x_1} = \frac{6 - \frac{3}{4}}{-2 - \frac{1}{2}} = \frac{\frac{21}{4}}{-\frac{5}{2}} = \left(\frac{21}{4}\right)\left(-\frac{2}{5}\right) = -\frac{105}{20}$$

$$16. m = \frac{y_2 - y_1}{x_2 - x_1} = \frac{8 - 3}{4 - (-2)} = \frac{5}{6}$$

$$17. m = \frac{y_2 - y_1}{x_2 - x_1} = \frac{11 - 11}{4 - (-17)} = \frac{0}{21} = 0$$

$$18. m = \frac{y_2 - y_1}{x_2 - x_1} = \frac{-19 - 2}{31 - 31} = \frac{-21}{0} = \text{undefined}$$

$$19. m = \frac{y_2 - y_1}{x_2 - x_1} = \frac{-1 - (-3)}{3 - 0} = \frac{2}{3}$$

$$20. m = \frac{y_2 - y_1}{x_2 - x_1} = \frac{2 - 7}{7 - 2} = \frac{-5}{5} = -1$$

$$21. m = \frac{y_2 - y_1}{x_2 - x_1} = \frac{\frac{1}{4} - 0}{\frac{2}{3} - 0} = \frac{\frac{1}{4}}{\frac{2}{3}} = \left(\frac{1}{4}\right)\left(\frac{3}{2}\right) = \frac{3}{8}$$

22. Since $y = 16$ is a horizontal line, it has a slope of zero.

23. Since $x = -99$ is a vertical line, it has an undefined slope.

24.

Section A: The interval is (5, 0.5) and (0, 0).

$$\text{rate of change} = \frac{0 - 0.5}{0 - 5} = \frac{-0.5}{-5} = 0.1 \text{ mile per minute}$$

Section B: The interval is (7, 0.5) and (5, 0.5).

Since the line is horizontal, we can determine he was stopped. Therefore, his speed was 0 mile per minute.

Section C: The interval is (7, 0.5) to (14, 1.2).

$$\text{rate of change} = \frac{1.2 - 0.5}{14 - 7} = \frac{0.7}{7} = 0.1 \text{ mile per minute}$$

Section D: The interval is (14, 1.2) to (20, 3).

$$\text{rate of change} = \frac{3 - 1.2}{20 - 14} = \frac{1.8}{6} = 0.3 \text{ mile per minute}$$

Section E: The interval is (20, 3) to (25, 3).

Since the line is horizontal, we can determine he was stopped. Therefore, his speed was 0 mile per minute.

Section F: The interval is (25, 3) to (30, 3.5).

$$\text{rate of change} = \frac{3.5 - 3}{35 - 30} = \frac{0.5}{5} = 0.1 \text{ mile per minute}$$

25. The interval is (4, 145) to (7, 300).

$$\text{rate of speed} = \frac{300 - 145}{7 - 4} = \frac{155}{3} \approx 51.7 \text{ miles per hour}$$

26. $\frac{60}{2\frac{1}{2}} = \frac{60}{\frac{5}{2}} = 60\left(\frac{2}{5}\right) = \24 each week

27. Geoffrey is riding on a ride at a fair. The first part of the ride climbs quickly. After 1 second on the ride, he is 10 feet in the air. After 3 seconds, he is 30 feet in the air.

28. The intercepts of $3x - 5y = 10$ are:

$$3x = 10$$

$$x = \frac{10}{3} \rightarrow \left(\frac{10}{3}, 0\right)$$

$$-5y = 10$$

$$y = \frac{10}{-5} = -2 \rightarrow (0, -2)$$

29.

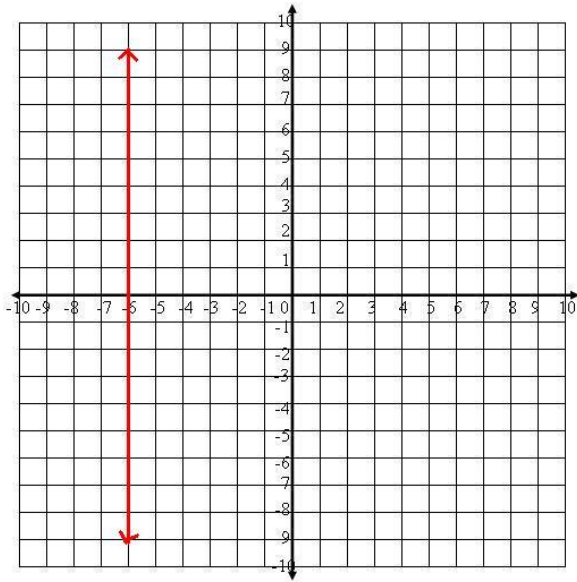

30.

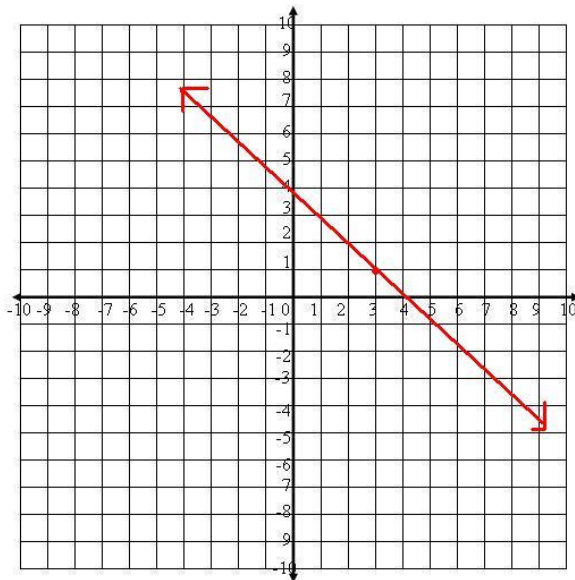

31. Let x = the number of quarters and y = the number of dimes. Then we can write $0.25x +$

$$0.10y = 4$$

$$0.10y = 4$$

$$y = \frac{4}{0.1} = 40 \rightarrow (0, 40)$$

$$0.25x = 4$$

$$x = \frac{4}{0.25} = 16 \rightarrow (16, 0)$$

32. Domain $\{-2, -1, 0, 1, 2\}$ Range $\{0, 1, 2\}$

33. $16y - 72 = 36$

$$16y = 108$$

$$y = 6.75$$

34. $3x + 1 = 2x - 35$

$$3x - 2x = -35 - 1 \text{ (combine like terms)}$$

$$x = -36 \text{ (simplify the left and right sides)}$$

35. $\frac{6}{a} = \frac{14}{2a+1}$

$$6(2a + 1) = 14a$$

$$12a + 6 = 14a$$

$$6 = 2a$$

$$a = 3$$

Quick Quiz

1. $3x + 6y = 25$

$$3x = 25$$

$$6y = 25$$

$$x = 8\frac{1}{3}$$

$$y = 4\frac{1}{6}$$

$$(8\frac{1}{3}, 0)$$

$$(0, 4\frac{1}{6})$$

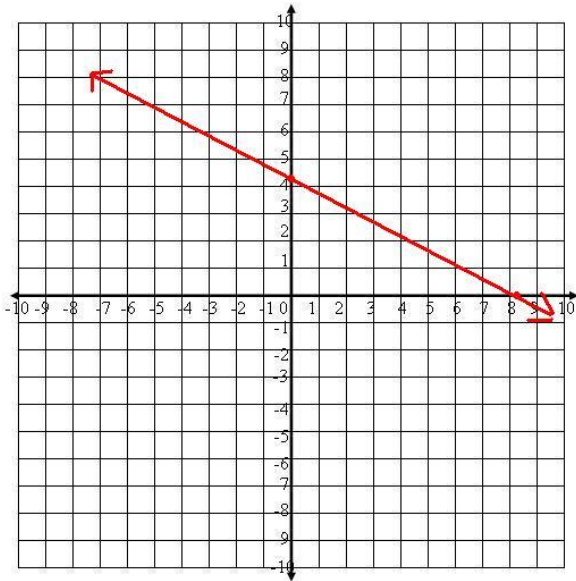

2. $(8, 5)$ and $(-5, 6)$

$$m = \frac{y_2 - y_1}{x_2 - x_1} = \frac{6 - 5}{-5 - 8} = \frac{1}{-13} = -\frac{1}{13}$$

3. $f(x) = 2x + 1$

x	$f(x) = 2x + 1$	$f(x)$
0	$f(0) = 2(0) + 1 = 1$	1
1	$f(1) = 2(1) + 1 = 3$	3
2	$f(2) = 2(2) + 1 = 5$	5
3	$f(3) = 2(3) + 1 = 7$	7

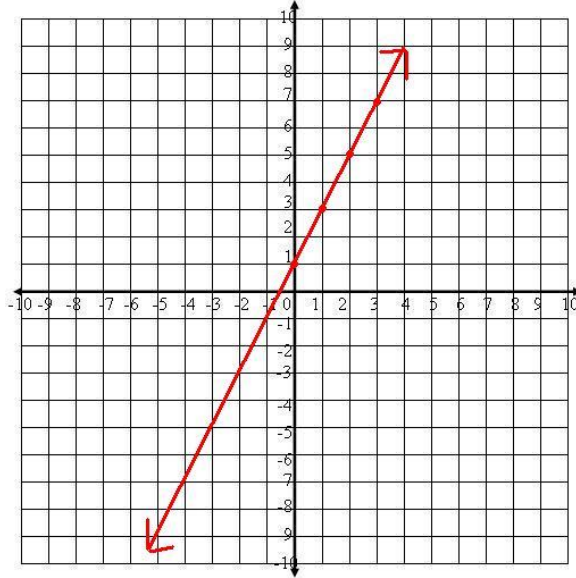

4.

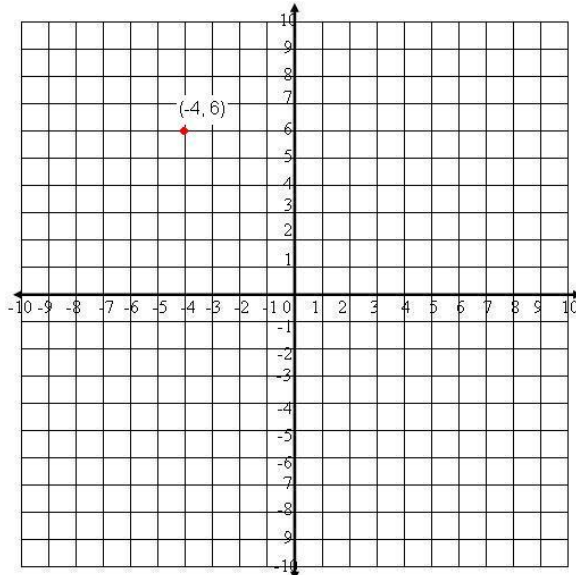

5. There are many possible solutions. Two trends are listed here:
- The number of students in public school increased every year from 1990 to 2000.
 - The rate of increase for the number of students was slower towards the end of the decade than the beginning of the decade.

Lesson 4.5

1. Slope (m) = 2; y-intercept (b) = 5
2. $m = -0.2$; $b = 7$
3. $m = 1$; $b = 0$
4. $m = 0$; $b = 3.75$
5. $m = \frac{2}{3}$; $b = -9$
6. $m = -0.01$; $b = 10,000$
7. $m = \frac{3}{5}$; $b = 7$
8. The slope of line F is down 2, and right 4, so $\frac{-2}{4} = -\frac{1}{2}$.
9. The slope of line C is 0.
10. The slope of line A is down 2, and right 1, so $\frac{-2}{1} = -2$.
11. The slope of line G is up 4, and right 1, so $\frac{4}{1} = 4$.
12. The slope of line B is down 4, and right 3, so $\frac{-4}{3} = -\frac{4}{3}$.
13. The slope of line D is up 2, and right 5, so $\frac{2}{5}$.
14. The slope of line E is down 2, and right 8, so $\frac{-2}{8} = -\frac{1}{4}$.
15. The slope of line D is -1 , and the y-intercept is 0.
16. The slope of line A is $-\frac{2}{3}$, and the y-intercept is about $1\frac{1}{3}$.
17. The slope of line F is $-\frac{1}{5}$, and the y-intercept is -2 .

18. The slope of line B is 3, and the y -intercept is 1.

19. The slope of line E is 0, and the y -intercept is 3.

20. The slope of line C is $\frac{1}{2}$, and the y -intercept is -2 .

21. $-5x + 12 = 20$

Since there is no y , then we know the line is vertical. Therefore, the line has undefined slope. It does not have a y -intercept.

22.

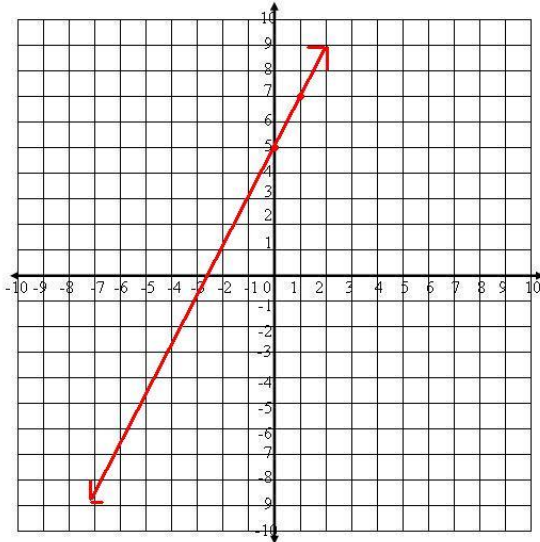

23.

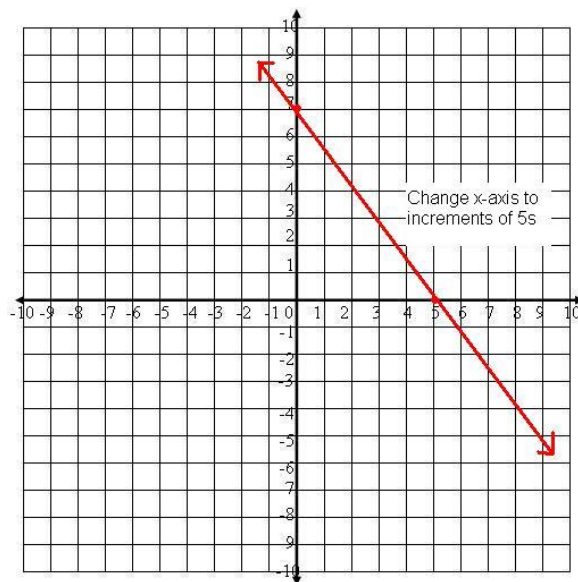

24.

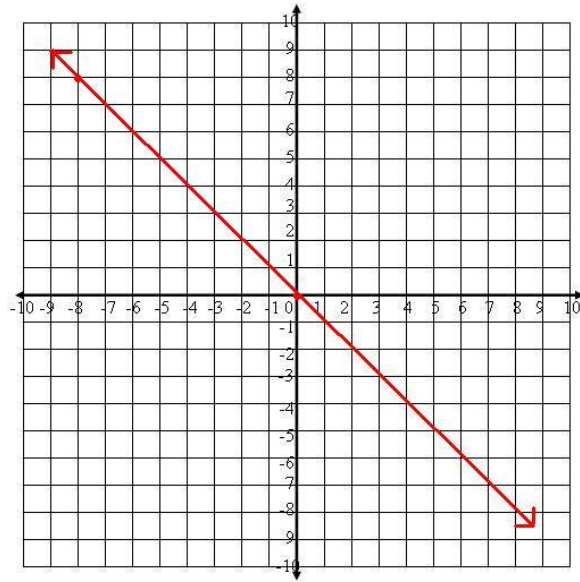

25.

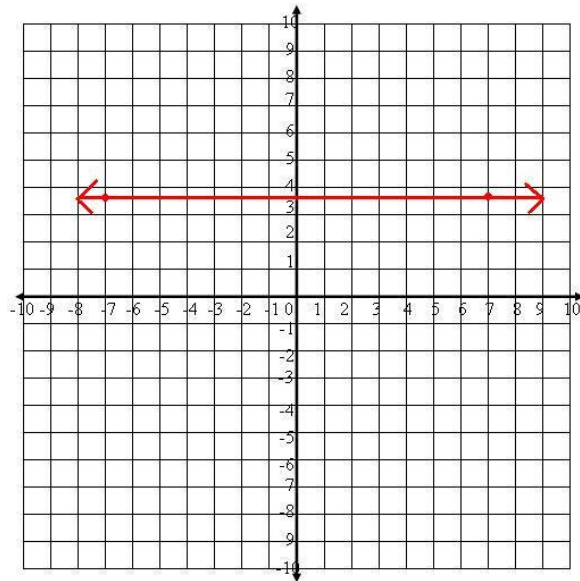

26.

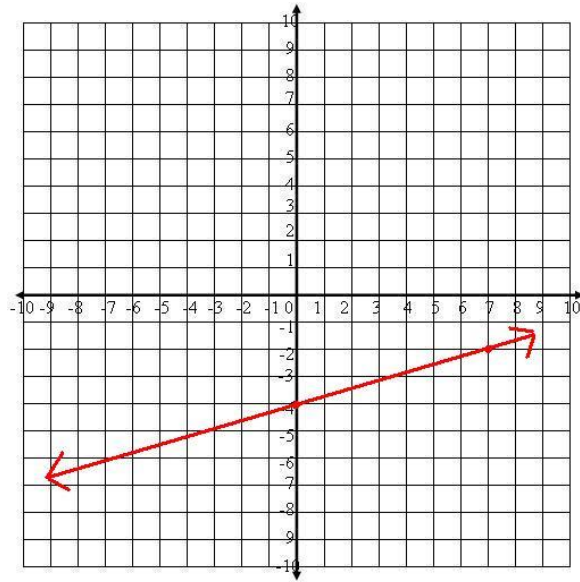

27.

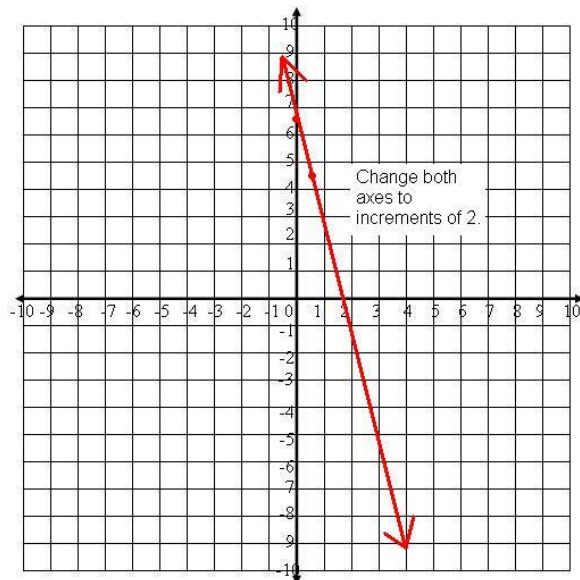

28.

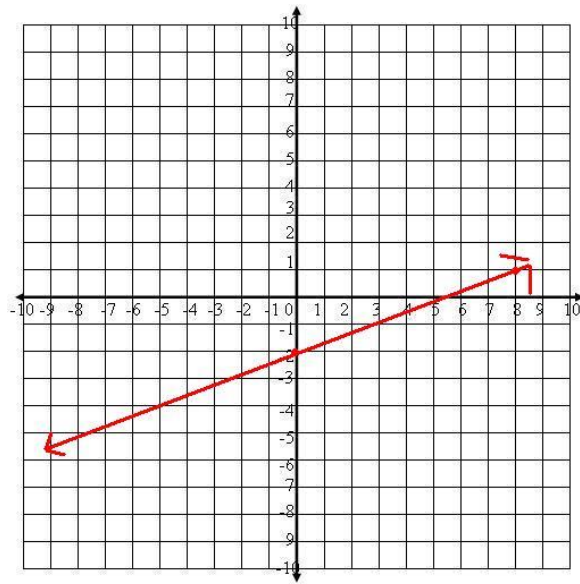

29.

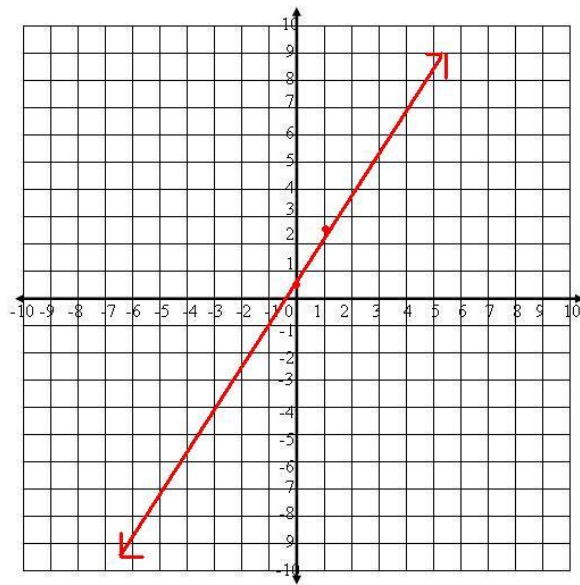

30. The slope of the given line is 2, so the slope of any line parallel to it will have a slope of 2.
31. The slope of the given line is -0.2 , so the slope of any line parallel to it will have a slope of -0.2 .
32. The slope of the given line is -1 , so the slope of any line parallel to it will have a slope of -1 .
33. The slope of the given line is 0, so the slope of any line parallel to it will have a slope of 0.
34. The slope of the given line is $-\frac{1}{5}$, so the slope of any line parallel to it will have a slope of $-\frac{1}{5}$.
35. The slope of the given line is -5 , so the slope of any line parallel to it will have a slope of -5 .
36. The slope of the given line is -3 , so the slope of any line parallel to it will have a slope of -3 .
37. The slope of the given line is 3, so the slope of any line parallel to it will have a slope of 3.

38.

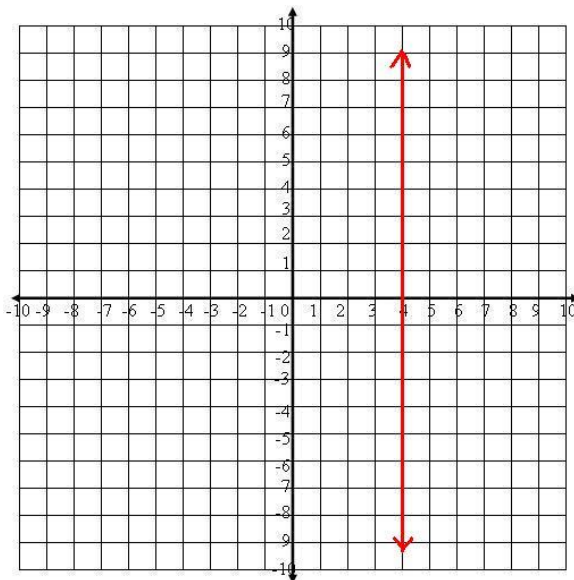

39. $|8 - 11| + 4g = 99$

$$|-3| + 4g = 99$$

$$3 + 4g = 99$$

$$4g = 96$$

$$g = 24$$

40. The order of operations:

“Whatever is found inside **PARENTHESES** must be done first. **EXPONENTS** are to be simplified next. **MULTIPLICATION** and **DIVISION** are equally important and must be performed moving left to right. **ADDITION** and **SUBTRACTION** are also equally important and must be performed moving left to right.” (page 6)

The order of operations are used for simplifying algebraic or numeric expressions.

41. One example of a negative irrational number is $-e$.

42. One example of a positive rational number $\frac{1}{2}$.

43. An integer is always a rational number because it can be written as the ratio of two integers.

Lesson 4.6

1. **Direct Variation** can be expressed as the equation $y = (k)x$, where k is called the constant of variation.

Direct variation occurs when:

- The fraction $\frac{\text{rise}}{\text{run}}$ or $\frac{\text{change in } y}{\text{change in } x}$ is always the same, and
- The ordered pair $(0, 0)$ is a solution to the situation.

2. The equation for direct variation is $y = k(x)$, where k is the constant of variation.
3. The two methods that can be used to solve a direct variation equation are:
 - a. graphing
 - b. Cross Products Theorem of proportions
4. It is **FALSE** that all linear equations are direct variation situations.
5. Let m = the amount of money earned, and h = the number of hours worked.
Then $m = kh$, where k is the constant of proportionality.
6. Let m = the weight on the moon, and w = the weight on Earth.
Then $m = kw$, where k is the constant of proportionality.
7. Let v = the volume of the gas, and t = the temperature of the gas in Kelvin.
Then $v = kt$, where k is the constant of proportionality.
8. Let p = the number of people served, and m = the amount of ground meat.
Then $p = km$, where k is the constant of proportionality.
9. Let c = the cost of purchase, and p = the number of pounds.
Then $c = kp$, where k is the constant of proportionality.
10. This is not direct variation because the x is in the denominator.
11. This is not direct variation because there is no x value.
12. This is not direct variation because there is no y value.
13. This is not direct variation because the graph does not pass through $(0, 0)$.
14. This is not direct variation because the graph does not pass through $(0, 0)$.

15.

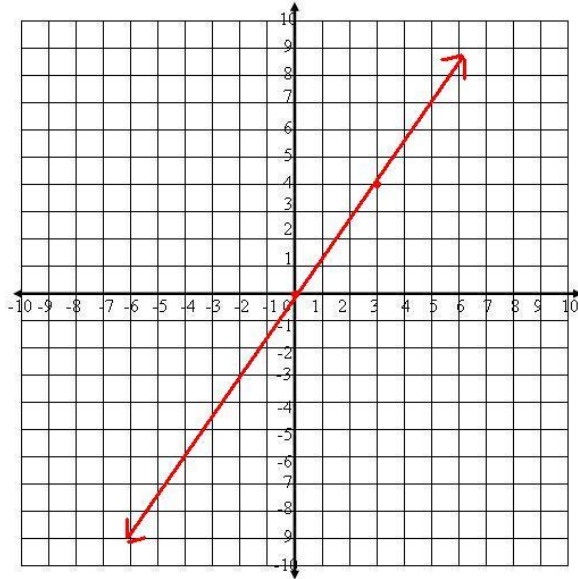

16.

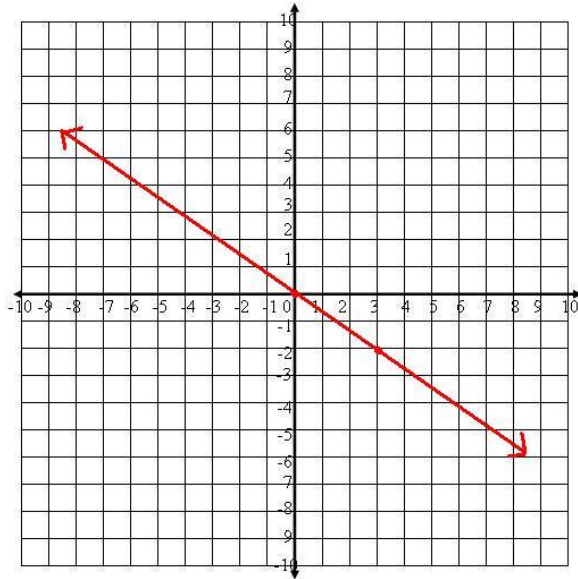

17.

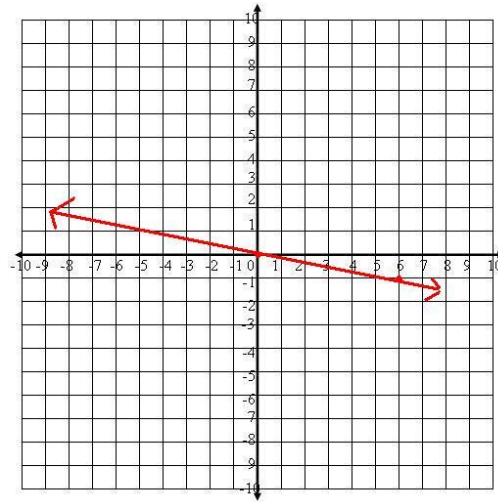

18.

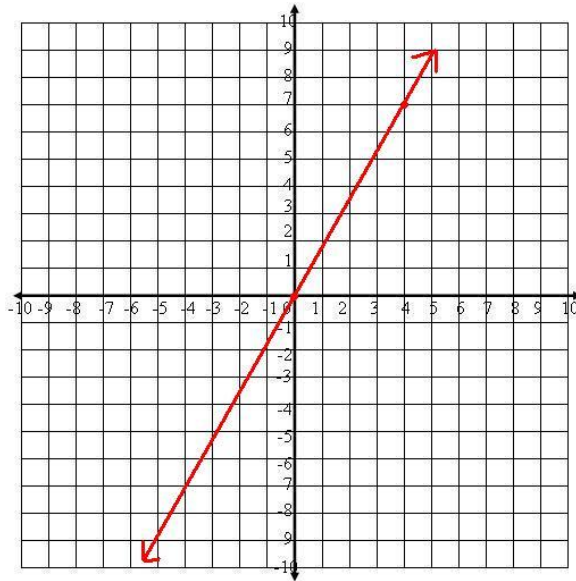

19. This is not direct variation because the graph does not pass through $(0, 0)$.

$$\begin{aligned} 20. \quad y &= kx \\ 48 &= k(4) \\ k &= \frac{48}{4} = 12 \end{aligned}$$

$$\begin{aligned} 21. \quad d &= kt \\ 329 &= k(7) \\ k &= \frac{329}{7} = 47 \end{aligned}$$

22. $l = kh$

$$48 = k(4)$$

$$k = \frac{112}{-16} = -7$$

23. $m = kh$

$$461.50 = k(89.6)$$

$$k = \frac{461.50}{89.6} \approx 5.15$$

24. $z = kr$

$$48 = k(4)$$

$$k = \frac{51.5}{412} = 0.125$$

25. Let c = the cost of the strawberries, and p = the number of pounds.

Then $c = kp$

$$12.50 = k(5)$$

$$k = \frac{12.50}{5} = 2.50$$

The equation for the cost of the strawberries is $c = 2.50p$.

26. Let s = the amount spent, and m = the number of minutes.

Then $s = km$

$$3.50 = k(10)$$

$$k = \frac{3.50}{10} = 0.35$$

The equation for the cost of the strawberries is $s = 0.35m$.

$$20.00 = 0.35m$$

$$m = \frac{20.00}{0.35} \approx 57.14$$

He can play games for about 57 minutes.

27. It would take $m = \frac{30}{2.5} = 12$ minutes.

28. Ohm's Law uses the equation $V = IR$. $V = 288$ and $I = 32$.

a. Therefore $k = \frac{288}{32} = 9$.

b. $\frac{288 \text{ volts}}{32 \text{ amps}} = \frac{V \text{ volts}}{65 \text{ amps}}$

$$32V = 18,720$$

$$V = 585 \text{ volts}$$

29. Let d = diameter, and c = circumference.

$$\frac{6.28}{2} = \frac{c}{15}$$

$$2c = 94.2$$

$$c = 47.1 \text{ inches}$$

30. The amount of time from 10 pm to 6 am is 8 hours. If d = the depth of the pool and t = time (in hours), then $d = kt$.

$$\frac{8}{4} = \frac{t}{7}$$

$t = 14$ hours until full

The pool will be full at 12 pm (10 pm to 10 am is 12 hours, so 14 hours is at 12 pm.)

$$31. \frac{200,500}{232} = \frac{p}{60}$$

$$232p = 120,300,000$$

$$p = \$51,853.45$$

32. $F = kx$

a. $12 = k(10)$

$$k = 1.2 \text{ N/cm}$$

b. $F = kx$

$$F = 1.2(7) = 8.4 \text{ N}$$

c. $F = kx$

$$23 = 1.2(x) \approx 19.7 \text{ cm}$$

33.

a. The slope is $\frac{3}{1} = 3$, so the equation is $y = 3x$.

b. The slope is $\frac{-2}{1} = -2$, so the equation is $y = -2x$.

c. The slope is $\frac{-1}{5} = -\frac{1}{5}$, so the equation is $y = -\frac{1}{5}x$.

d. The slope is $\frac{2}{9}$, so the equation is $y = \frac{2}{9}x$.

34. $3x = 48$

$$x = \frac{48}{3} = 16$$

The x-intercept is (16, 0).

$$4y = 48$$

$$y = \frac{48}{4} = 12$$

The y-intercept is (12, 0).

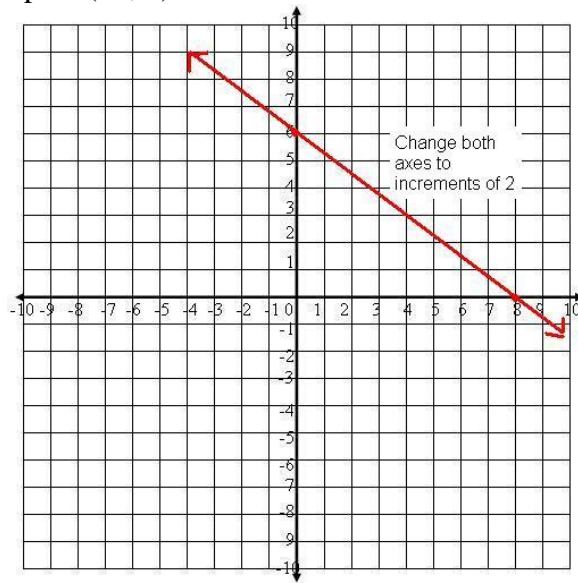

35.

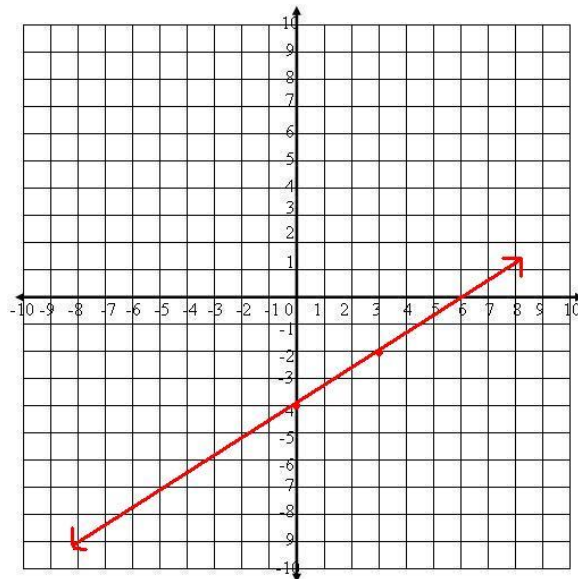

36. $4(u + 3) = 3(3u - 7)$

$$4u + 12 = 9u - 21$$

$$5u = 33$$

$$u = \frac{33}{5} = 6\frac{3}{5}$$

37. The slope of the first line is $\frac{1}{2}$.

$$2y = x + 2$$

$$y = \frac{1}{2}x + 1$$

The slope of the second line is $\frac{1}{2}$, so the lines are parallel.

38. The point $(-99, 100)$ lies in the second quadrant (QII).

$$39. m = \frac{y_2 - y_1}{x_2 - x_1} = \frac{7 - 0}{3 - 2} = \frac{7}{1} = 7$$

$$40. \text{ When } a = -3 \text{ and } b = 4, \text{ then } \frac{1 + 4b}{2a - 5b} = \frac{1 + 4(4)}{2(-3) - 5(4)} = \frac{17}{-6 - 20} = \frac{17}{-26} = -\frac{17}{26}.$$

Lesson 4.7

1. $f(x)$ reads f of x
2. Function notation allows you to easily see the input value for the independent variable inside the parentheses (p. 155). This is helpful because it will allow you to easily plot the graph of a function.
3. A **function** is a relationship between two variables such that the input value has ONLY one unique output value.
4. This graph is a function because it passes the Vertical Line Test.
5. This graph is not a function because it fails the Vertical Line Test. A vertical line will touch the graph in more than one place at one time.
6. This graph is not a function because it fails the Vertical Line Test. A vertical line will touch the graph in more than one place at one time.
7. This graph is a function because it passes the Vertical Line Test.
8. $f(x) = 7x - 21$
9. $6x + 8y = 36$
 $8y = -6x + 36$
 $y = -\frac{3}{4}x + \frac{9}{2}$
 $f(x) = -\frac{3}{4}x + \frac{9}{2}$
10. $x = 9y + 3$
 $9y = x - 3$
 $y = \frac{1}{9}x - \frac{1}{3}$
 $f(x) = \frac{1}{9}x - \frac{1}{3}$
11. $f(x) = 6$
12. $f(t) = 65t + 100$
13. $f(C) = 1.8C + 32$
14. $f(m) = 0.10m + 25,000$

$$15. f(-3) = -2(-3) + 3 = 6 + 3 = 9$$

$$f(7) = -2(7) + 3 = -14 + 3 = -11$$

$$f(0) = -2(0) + 3 = 0 + 3 = 3$$

$$f(z) = -2(z) + 3 = -2z + 3$$

$$16. f(-3) = -0.7(-3) + 3.2 = 2.1 + 3.2 = 5.3$$

$$f(7) = -0.7(7) + 3.2 = -4.9 + 3.2 = -1.7$$

$$f(0) = -0.7(0) + 3.2 = 0 + 3.2 = 3.2$$

$$f(z) = -0.7(z) + 3.2 = -0.7z + 3.2$$

$$17. f(-3) = \frac{5(2 - (-3))}{11} = \frac{5(5)}{11} = \frac{25}{11}$$

$$f(7) = \frac{5(2 - 7)}{11} = \frac{5(-5)}{11} = \frac{-25}{11}$$

$$f(0) = \frac{5(2 - 0)}{11} = \frac{5(2)}{11} = \frac{10}{11}$$

$$f(z) = \frac{5(2 - z)}{11} = \frac{10 - 5z}{11}$$

$$18. f(-3) = \frac{1}{2}(-3)^2 + 4 = \frac{1}{2}(9) + 4 = \frac{9}{2} + 4 = \frac{9+8}{2} = \frac{17}{2}$$

$$f(7) = \frac{1}{2}(7)^2 + 4 = \frac{1}{2}(49) + 4 = \frac{49}{2} + 4 = \frac{49+8}{2} = \frac{57}{2}$$

$$f(0) = \frac{1}{2}(0)^2 + 4 = 0 + 4 = 4$$

$$f(z) = \frac{1}{2}(z)^2 + 4 = \frac{1}{2}z^2 + 4$$

$$19. f(-3) = 3 - \frac{1}{2}(-3) = 3 + \frac{3}{2} = \frac{6+3}{2} = \frac{9}{2}$$

$$f(7) = 3 - \frac{1}{2}(7) = 3 - \frac{7}{2} = \frac{6-7}{2} = \frac{-1}{2}$$

$$f(0) = 3 - \frac{1}{2}(0) = 3$$

$$f(z) = 3 - \frac{1}{2}(z) = 3 - \frac{1}{2}z$$

20.

a. Since x = the number of pounds, the function would be $f(x) = 8x + 100$.

b. $f(10) = 8(10) + 100 = 80 + 100 = 180$ minutes

c. $f(27) = 8(27) + 100 = 216 + 100 = 316$ minutes

d. 4.5 hours = $60(4.5) = 270$ minutes

$$270 = 8x + 100$$

$$170 = 8x$$

$$x = 21.25 \text{ pounds}$$

21. $F(C) = 1.8C + 32 \rightarrow F(100) = 1.8(100) + 32 = 212$

The temperature equivalent of 100°C is 212°F .

22. Let m = the number of minutes. Then the function is $f(m) = 20 - 0.16m$.

$$0 = 20 - 0.16m$$

$$-20 = -0.16m$$

$$m = 125$$

One can talk for 125 minutes.

23. We know that $b(1) = 330$, so our function is $b(h) = 330h$.

$$b(0.75) = 330(0.75) = 247.5 \text{ calories}$$

24. Let w = the number of weeks.

a. The function is $f(w) = 650 - 55w$.

b. $f(10) = 650 - 55(10) = 650 - 550 = 100$

Sadie has \$100 left in her account.

25. $-120\left(\frac{1}{2}\right)\left(\frac{3}{5}\right) = \frac{-360}{10} = -36$

26. $7\frac{1}{4} + 3\frac{2}{3} + 5\frac{3}{4} = \frac{29}{4} + \frac{11}{3} + \frac{23}{4} = \frac{29(3) + 11(4) + 23(3)}{12} = \frac{87 + 44 + 69}{12} = \frac{200}{12} = 16\frac{2}{3}$

27. $-3(4m + 11) = -12m - 33$

28. Because we are not given specifics, we have to go by what is given. The amount of income taxes is dependent on the amount of one's salary. However, y = taxes paid, which could be sales tax. In addition, some places do not collect state income tax. So, with the given information, we cannot determine if this situation is a function or not.

29. $y = kz$

$$450 = k(6)$$

$$k = 75$$

30. 30 minutes = 0.5 hours

$$\frac{15 \text{ gallons}}{2.5 \text{ hours}} = \frac{x \text{ gallons}}{0.5 \text{ hours}}$$

$$7.5 = 2.5x$$

$$x = 3 \text{ gallons}$$

Lesson 4.8

1.

a. $\frac{30}{250} = \frac{40}{\text{Earnings}}$

$$\text{Earnings} = 250(40) \div 30 = \$333.33$$

c. It took 30 hours to earn \$250.

d. Two points on the graph are (0, 50) and (30, 250).

$$m = \frac{y_2 - y_1}{x_2 - x_1} = \frac{250 - 50}{30 - 0} = \frac{200}{30} = 6.67$$

The slope represents the amount the amount Aatif makes per hour.

2. Two points along the linear function are (2, 12) and (5, 18), where x = the amount of weight and y = the number of inches stretched. We can graph these points on a graph.

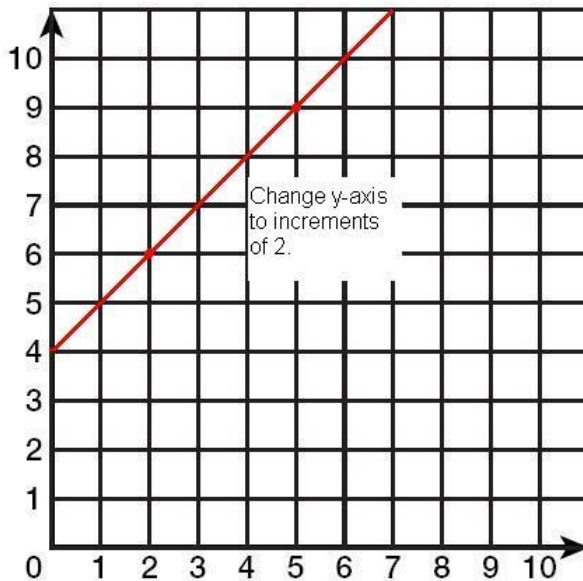

Based on the graph, the length of the spring is 4 inches when no weight is added.

3. Let c = the cost and m = the number of months.

Our equation will be $c = 200 + 39m$. The cost for 12 months will be $200 + 39(12) = \$668$.

4. Two points along the linear function are (2, 5) and (8, 3), where x = the number of minutes and y = the length of the candle. We can graph these points on a graph.

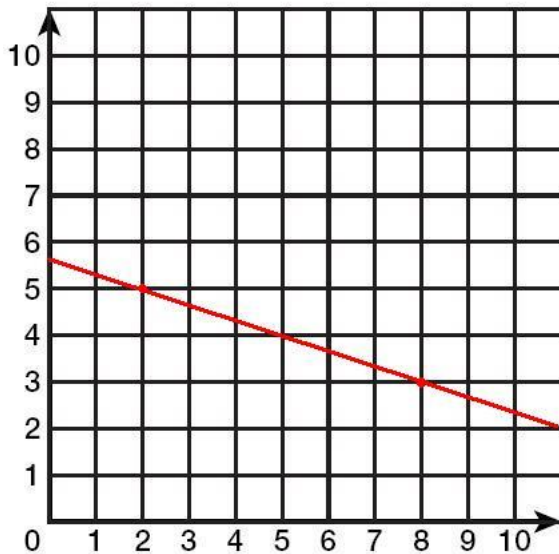

According to the graph, the original length of the graph was about 5.5 inches.

5. $\frac{1.25 \text{ inches}}{550 \text{ pages}} \approx 0.002 \text{ inches per page}$

6. Let g = the number of glasses of lemonade. Then the equation will be
 $0.45g = 25$
 $g = 55.56 \approx 56$ glasses

7. $\frac{78.00}{9.20} = \frac{21.50}{\text{tip}}$
 $\text{tip} = 21.50(9.20) \div 78.00 = \2.54

8. First, it is important to notice that the rate (speed) is in miles per hour, while the time is given in minutes. It is easier to convert the minutes to hours rather than the speed.

$$30 \text{ minutes} \left(\frac{1 \text{ hour}}{60 \text{ minutes}} \right) = 0.5 \text{ hours}$$

$$25 \text{ minutes} \left(\frac{1 \text{ hour}}{60 \text{ minutes}} \right) \approx 0.417 \text{ hours}$$

$$45 \text{ minutes} \left(\frac{1 \text{ hour}}{60 \text{ minutes}} \right) \approx 0.75 \text{ hours}$$

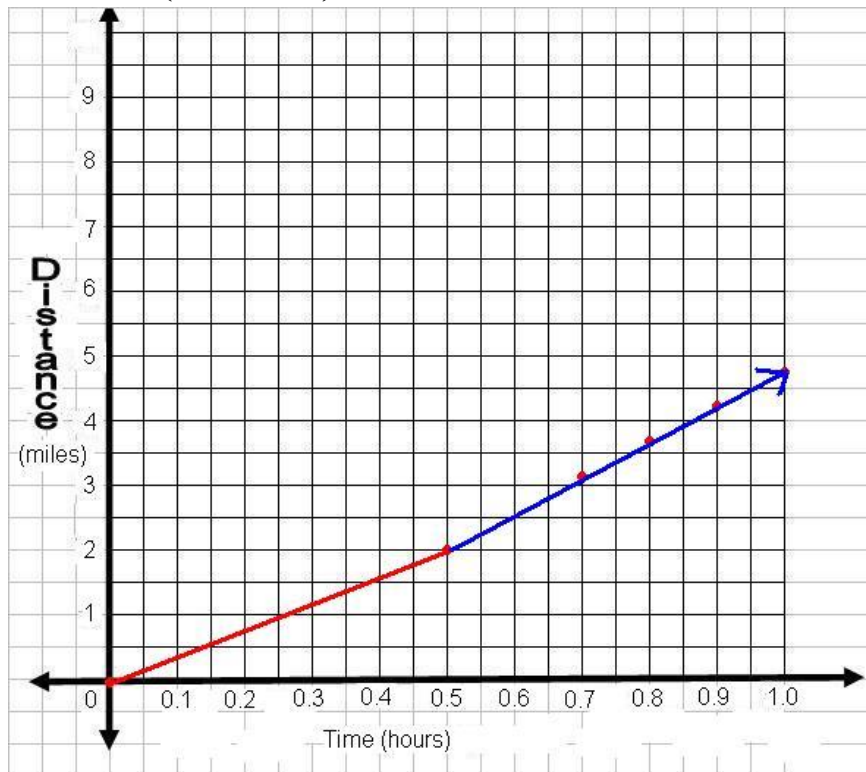

According to the graph, after 45 minutes, Karen is approximately 3.4 miles from her home.

9. $-4|-21 - 11| + 16 = -4|-31| + 16 = -4(31) + 16 = -124 + 16 = -108$

10. $y = 3.5x$, where 3.5 is the constant of variation.

11. $\frac{5}{3}x = y - 4$

$$y = \frac{5}{3}x + 4$$

$$m = \frac{5}{3}; b = 4$$

12. A rule to move point A to Quadrant III would be $(-x, -y)$.

$$\begin{array}{ll} 13. 0.04x = 18 & 0.06y = 18 \\ x = 450 & y = 300 \\ (450, 0) & (0, 300) \end{array}$$

$$14. f(4) = \frac{3(4)^2}{8} = \frac{3(16)}{8} = \frac{48}{8} = 6$$

Lesson 4.9 Chapter 4 Review

1. x -intercept – the location where a graph crosses the x -axis
2. y -intercept – the location where a graph crosses the y -axis
3. **Direct Variation** can be expressed as the equation $y = (k)x$, where k is called the constant of variation.
Direct variation occurs when:
 - The fraction $\frac{\text{rise}}{\text{run}}$ or $\frac{\text{change in } y}{\text{change in } x}$ is always the same, and
 - The ordered pair $(0, 0)$ is a solution to the situation.
4. Parallel lines are lines that will never intersect.
5. rate of change – When finding the slope of real-world situations, it is often referred to as **rate of change**. “Rate of change” means the same as “slope.”
6. $(5, 1)$
7. $(-5, -5)$
8. $(0, 7)$
9. $(-8, 9)$
10. $(-4, 0)$
11. $(6, -2)$

12. – 16.

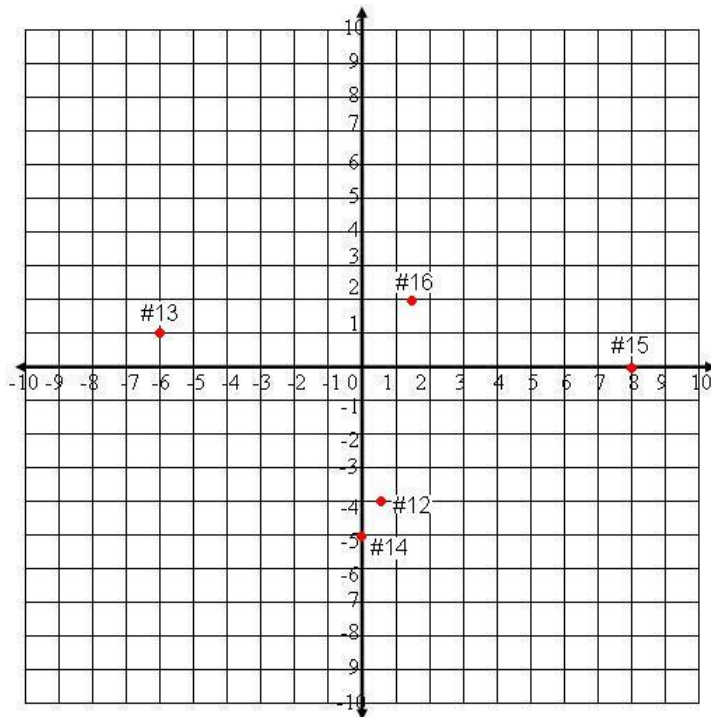

17.

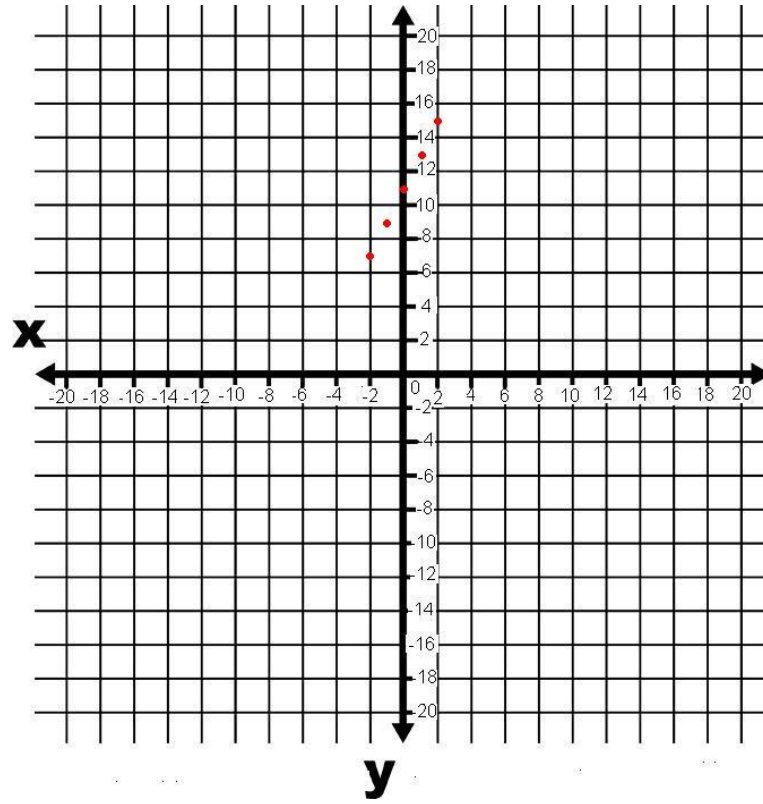

18.

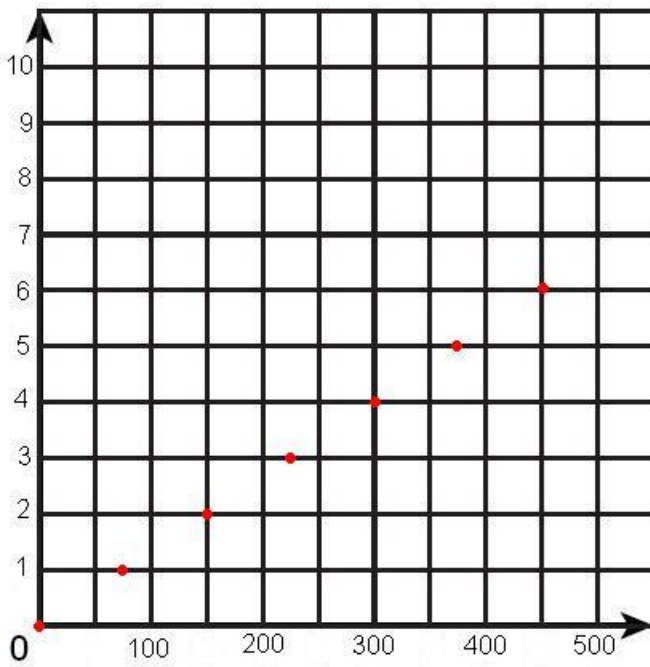

19. – 24.

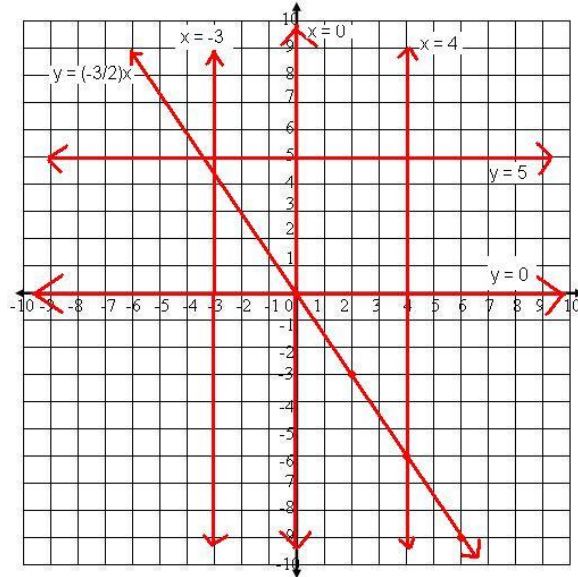

25. $y = 4x - 5$
 $y = -5$, so y -intercept is $(0, 5)$

$0 = 4x - 5$
 $5 = 4x$
 $x = \frac{5}{4}$, so x -intercept is $(\frac{5}{4}, 0)$

26. $5x = 20$
 $x = 4$
 x -intercept $(4, 0)$

$5y = 20$
 $y = 4$
 y -intercept $(0, 4)$

27. $x = 7$
 x -intercept $(7, 0)$

$y = 7$
 y -intercept $(0, 7)$

28. $-16x = 48$
 $x = -3$
 x -intercept $(-3, 0)$

$8y = 48$
 $y = 6$
 y -intercept $(0, 6)$

29. $3x = 21$
 $x = 7$
 x -intercept $(7, 0)$

$7y = 21$
 $y = 3$
 y -intercept $(0, 3)$

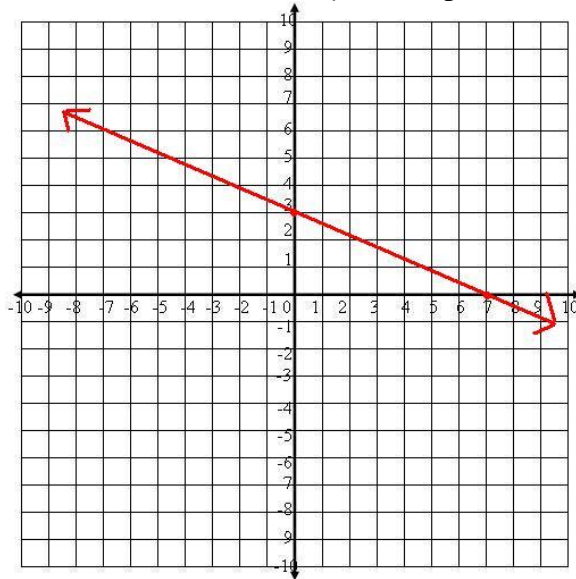

30. $-5x = 10$
 $x = -2$
 x -intercept $(-2, 0)$

$2y = 10$
 $y = 5$
 y -intercept $(0, 5)$

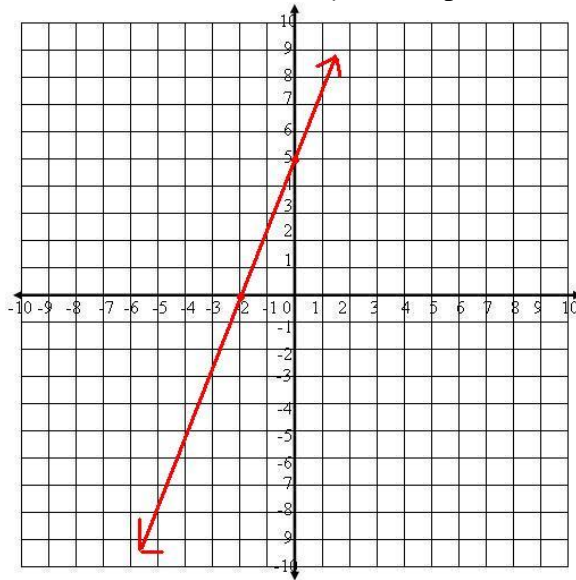

31. $x = 4$
 x -intercept $(4, 0)$

$-y = 4$
 y -intercept $(0, -4)$

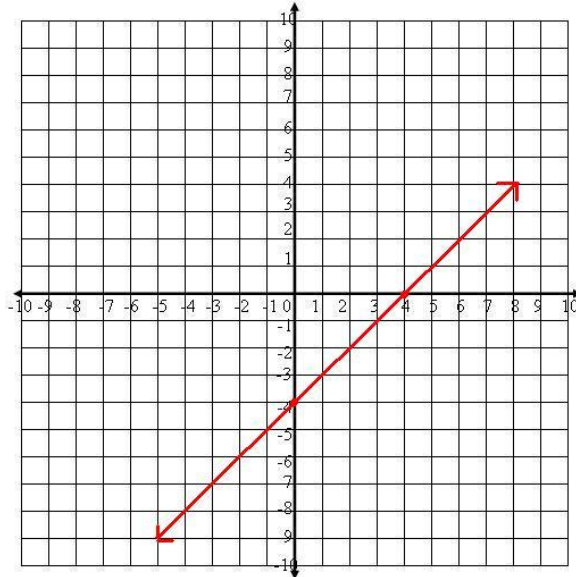

32. $16x = 16$
 $x = 1$
 x -intercept $(1, 0)$

$8y = 16$
 $y = 2$
 y -intercept $(0, 2)$

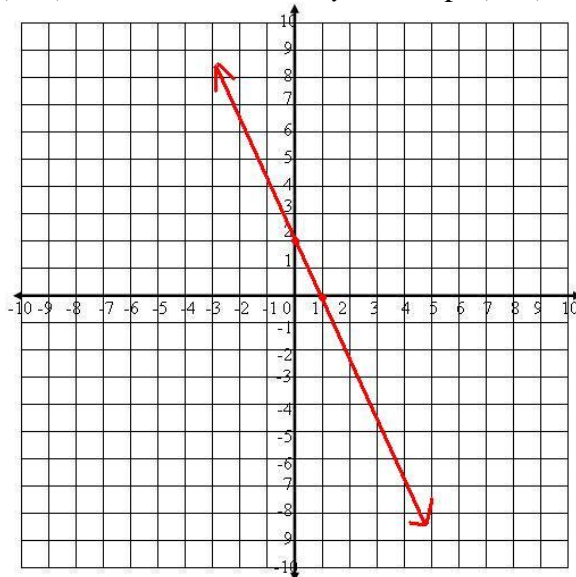

33. $x = 18$
 x -intercept $(18, 0)$

$9y = 18$
 $y = 2$
 y -intercept $(0, 2)$

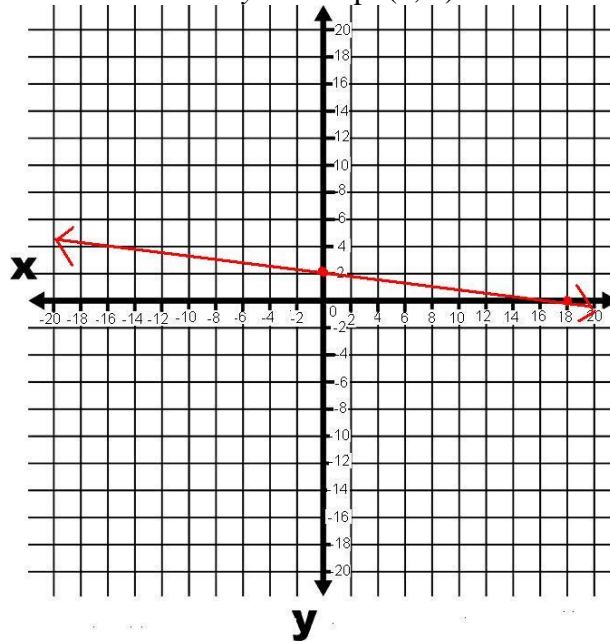

34. $\frac{1}{7}x = 7$
 $x = 49$
 x -intercept $(49, 0)$

$7 + y = 0$
 $y = -7$
 y -intercept $(0, -7)$

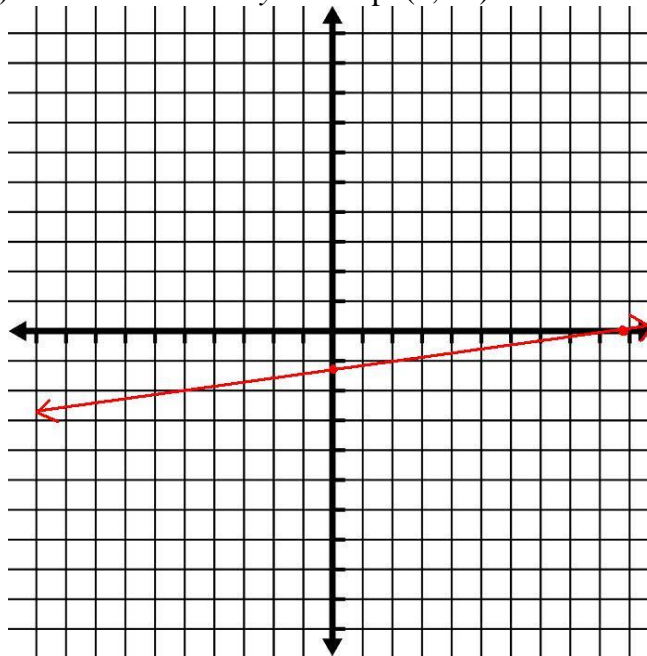

35. $m = \frac{y_2 - y_1}{x_2 - x_1} = \frac{8 - 20}{19 - 3} = \frac{-12}{16} = -\frac{3}{4}$

$$36. m = \frac{y_2 - y_1}{x_2 - x_1} = \frac{0 - 5}{12 - 12} = \frac{-5}{0} = \text{undefined}$$

$$37. m = \frac{y_2 - y_1}{x_2 - x_1} = \frac{3 - 5}{\frac{3}{2} - \left(\frac{-1}{2}\right)} = \frac{-2}{\frac{4}{2}} = \frac{-2}{2} = -1$$

$$38. m = \frac{y_2 - y_1}{x_2 - x_1} = \frac{3 - 3}{12 - 8} = \frac{0}{4} = 0$$

$$39. m = \frac{y_2 - y_1}{x_2 - x_1} = \frac{-22 - 17}{-14 - 14} = \frac{-39}{-28} = \frac{39}{28}$$

$$40. m = \frac{y_2 - y_1}{x_2 - x_1} = \frac{6 - 4}{18 - 1} = \frac{2}{17}$$

$$41. m = \frac{y_2 - y_1}{x_2 - x_1} = \frac{-6 - 6}{10 - 10} = \frac{-12}{0} = \text{undefined}$$

$$42. m = \frac{y_2 - y_1}{x_2 - x_1} = \frac{5 - 2}{19 - (-3)} = \frac{3}{22}$$

$$43. m = \frac{y_2 - y_1}{x_2 - x_1} = \frac{9 - 9}{13 - 2} = \frac{0}{11} = 0$$

$$44. m = \frac{y_2 - y_1}{x_2 - x_1} = \frac{6 - (-1)}{-10 - 10} = \frac{7}{-20} = -\frac{7}{20}$$

$$45. \frac{150 \text{ pages}}{3 \text{ hours}} = 50 \text{ pages/hour}$$

$$46. \frac{65 \text{ onions}}{1.5 \text{ hours}} = 43\frac{1}{3} \text{ onions/hour}$$

$$47. \frac{215 \text{ miles}}{3.9 \text{ hours}} \approx 55.13 \text{ miles/hour}$$

$$48. \frac{65 \text{ jumping jacks}}{1 \text{ minute}} = 65 \text{ jumping jacks/minute}$$

$$49. \frac{\$48.60}{2,430 \text{ texts}} = \$0.02/\text{text}$$

50. $\frac{65 \text{ hotdogs}}{22 \text{ minutes}} \approx 2.95 \text{ hotdogs/minute}$

51. $x + y = 3$
 $y = -x + 3$
slope = -1 ; y-intercept = 3

52. $\frac{1}{3}x = 7 + y$
 $y = \frac{1}{3}x - 7$
slope = $\frac{1}{3}$; y-intercept = -7

53. $y = \frac{2}{5}x + 3$
slope = $\frac{2}{5}$; y-intercept = 3

54. $x = 4$
slope = undefined, no y-intercept

55. $y = \frac{1}{4}$
slope = 0 , y-intercept = $\frac{1}{4}$

56.

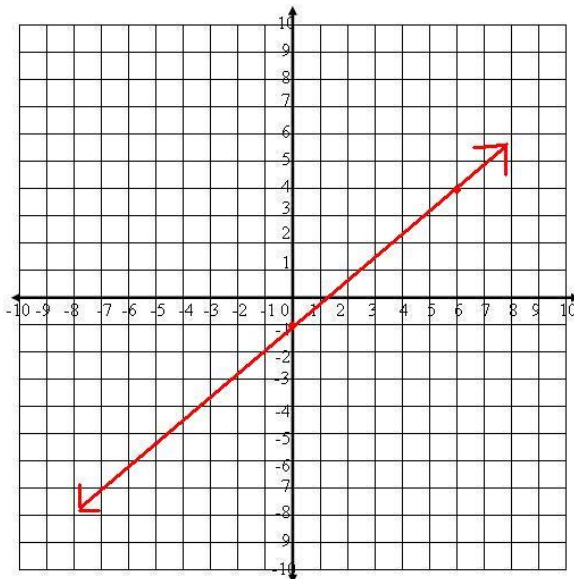

57.

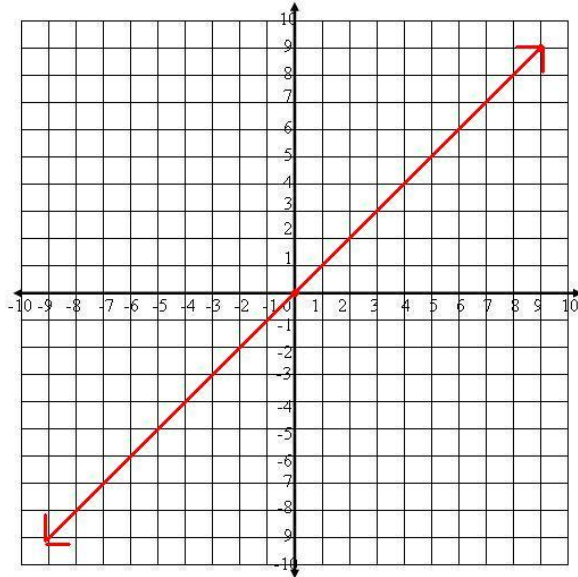

58.

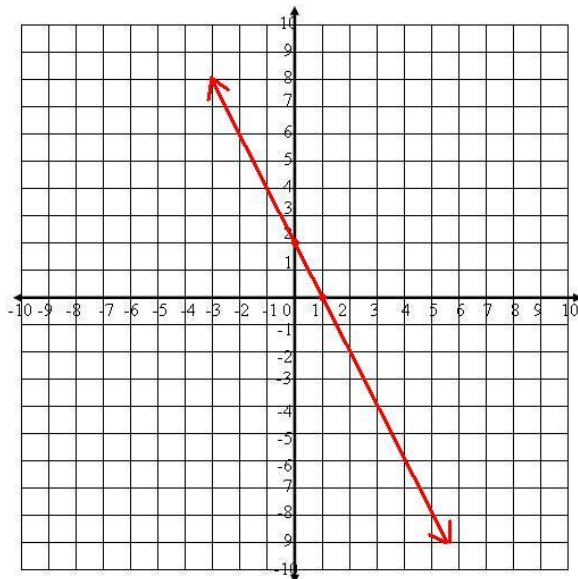

59.

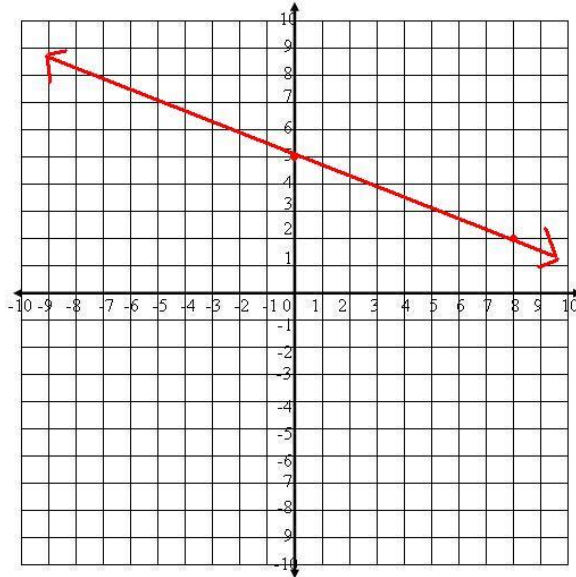

60.

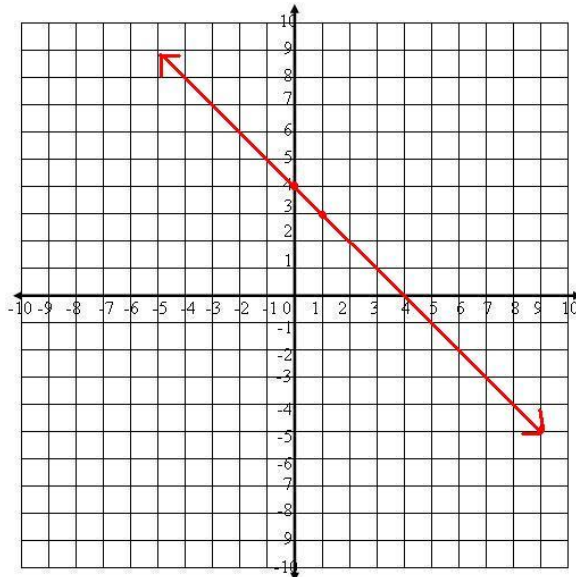

61. $3x + 6y = 8$
 $6y = -3x + 8$
 $y = -\frac{1}{2}x + \frac{4}{3}$

The slope of the first line is $-\frac{1}{2}$. The slope of the second line is 2. Therefore the lines are not parallel.

62. The slope of the first line is 1. The slope of the second line is -1 . Therefore the lines are not parallel.

$$63. \begin{aligned} 2x + 4y &= 16 \\ 4y &= -2x + 16 \\ y &= -\frac{1}{2}x + 4 \end{aligned}$$

The slope of the first line is $-\frac{1}{2}$. The slope of the second line is $-\frac{1}{2}$. Therefore the lines are parallel.

$$64. g(7) = -2|7 - 3| = -2(4) = -8$$

$$65. h(8) = 8^2 - 4(8) = 64 - 32 = 32$$

$$66. p\left(\frac{1}{6}\right) = 3\left(\frac{1}{6}\right) + 1 = \frac{1}{2} + 1 = \frac{3}{2}$$

$$67. g(-3) = 4|-3| = 4(3) = 12$$

$$68. h(24) = \frac{1}{3}(24) - 4 = 8 - 4 = 4$$

$$69. f(20) = \frac{20+8}{6} = \frac{28}{6} = \frac{14}{3}$$

$$70. r(26.99) = 0.06(26.99) = 1.6194$$

$$71. \begin{aligned} \frac{168}{4} &= \frac{m}{7} \\ 4m &= 1176 \\ m &= 294 \text{ miles} \end{aligned}$$

$$72. C(84) = \frac{84-32}{1.8} \approx 28.9^\circ\text{C}$$

73. Let h = the number of hours. Since the rate of cookie baking is 12/30 minutes, that translates to 24 cookies/hour. We can write an equation to model this.

$$176 = 24h + 32$$

$$144 = 24h$$

$$h = 6$$

It will take 6 hours to have 176 cookies.

74. Let the amount of 12% concentration mixture = a

Therefore the amount of 8% concentration mixture = $60 - a$.

Therefore sum of acid in each mixture is equal to acid in solution

$$0.12a + 0.08(60 - a) = 6$$

$a = 30$ Mixture A = 30 ounces, Mixture B = 30 ounces

$$75. \frac{5 \text{ units}}{5,000 \text{ gallons}} = \frac{x \text{ units}}{7,500 \text{ gallons}}$$

$$5,000x = 37,500$$

$$x = 7.5 \text{ units of chlorine}$$

76.

(i) Let $T(c) = 15c + 40$

(ii)

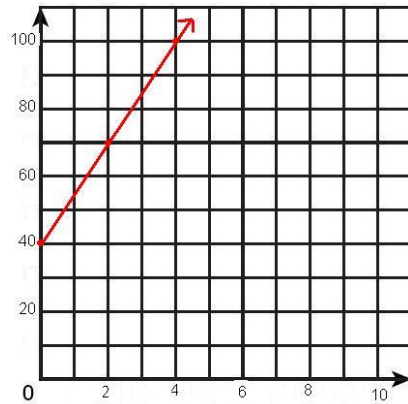

(iii) $67 = 15c + 40$
 $27 = 15c$
 $c = 1.8 \approx 2$

(iv) The y-intercept means there are no cricket chirps.

(v) The graph cannot interpret temperatures below 40 degrees because there cannot be a negative number of cricket chirps.

Lesson 4.10 Chapter 4 Test

1. $A(-4, 5)$
2. $B(0, -2)$
3. $C(3, 6)$

4.

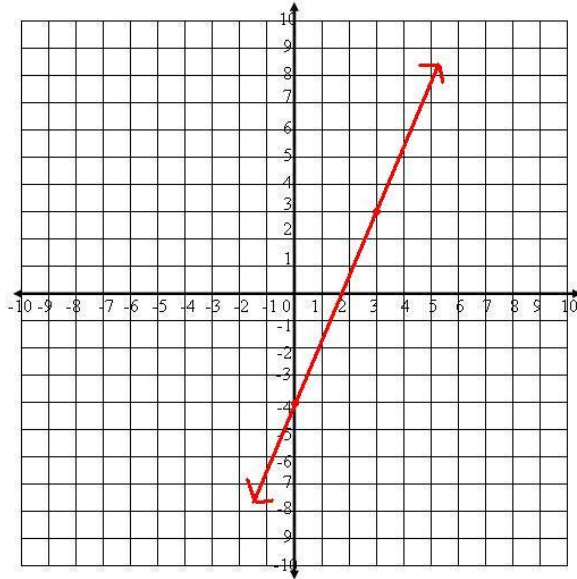

$$5. m = \frac{y_2 - y_1}{x_2 - x_1} = \frac{-2.25 - 5}{-1.25 - (-3)} = \frac{-7.25}{1.75} \approx -4.14$$

$$6. \begin{array}{ll} 6x = 54 & 9y = 54 \\ x = 9 & y = 6 \\ (9, 0) & (0, 6) \end{array}$$

$$7. \frac{84.6 - 86.3}{2008 - 2004} = \frac{-1.7}{4} \approx 0.425$$

The graduation rate will continue to decrease over the next 4 years.

$$8. \begin{array}{l} 4x + 7y = 28 \\ 7y = -4x + 28 \\ y = -\frac{4}{7}x + 4 \end{array}$$

$$\text{Slope} = -\frac{4}{7}; \text{y-intercept} = 4$$

$$9. \text{Slope} = -\frac{3}{5}; \text{y-intercept} = -8$$

10.

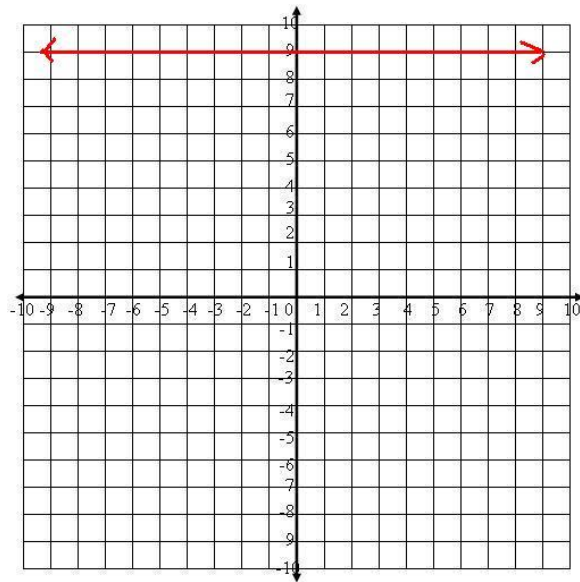

11.

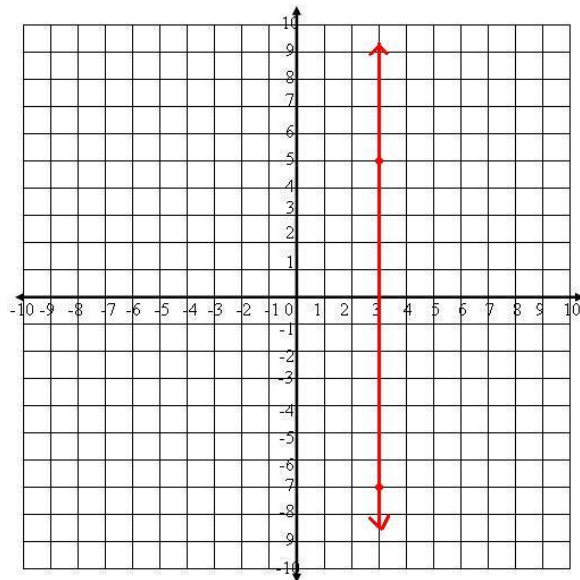

$$12. \frac{26 \text{ quarts}}{104 \text{ cups}} = \frac{2.75 \text{ quarts}}{x \text{ cups}}$$
$$26x = 286$$
$$x = 11 \text{ cups}$$

13.

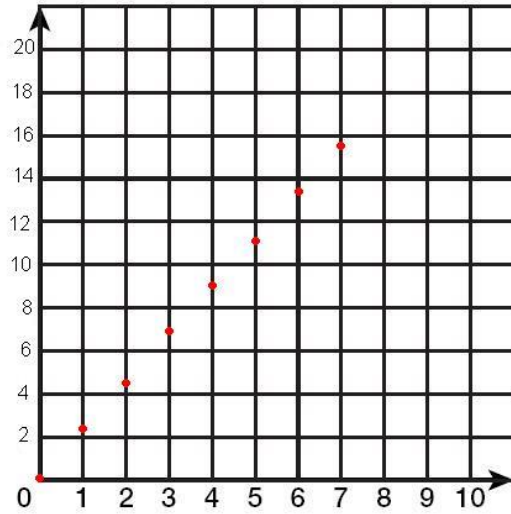

$$\begin{aligned} 14. \quad \frac{27}{4} &= \frac{h}{-5.5} \\ 4h &= -148.5 \\ h &= -37.125 \end{aligned}$$

$$15. \quad h(25) = \frac{1}{2}|6 - 25| + 11 = \frac{1}{2}(21) + 11 = 21.5$$

16. The two lines are not parallel because the slopes of the lines are different.

$$\begin{aligned} 17. \quad 0.02A + 0.015B &= \text{total} \\ \text{When } A = 6, \text{ total} &= 0.51 \\ 0.02(6) + 0.015B &= 0.51 \\ 0.12 + 0.015B &= 0.51 \\ 0.015B &= 0.39 \\ B &= 26 \text{ ounces} \end{aligned}$$

Chapter 5

Lesson 5.1

1. The formula for an equation in slope-intercept form is $y = mx + b$, where $m =$ slope and $b =$ the y -intercept.
2. **Step 1:** Begin by writing the formula for slope-intercept form $y = mx + b$.
Step 2: Substitute the given slope for m .
Step 3: Use the ordered pair you are given (x, y) , substitute these values for the variables x and y in the equation.
Step 4: Solve for b (the y -intercept of the graph).
Step 5: Rewrite the original equation in step 1, substituting the slope for m and the y -intercept for b .
3. You will need to find the slope of the line first.
4. $m = 7$ and y -intercept $= -2$, so the equation is $y = 7x - 2$
5. $m = -5$ and y -intercept $= 6$, so the equation is $y = -5x + 6$
6. $m = -2$ and y -intercept $= 7$, so the equation is $y = -2x + 7$
7. $m = \frac{2}{3}$ and y -intercept $= \frac{4}{5}$, so the equation is $y = \frac{2}{3}x + \frac{4}{5}$

8. $m = -\frac{1}{4}$ and contains $(4, -1)$

$$\text{Then } -1 = -\frac{1}{4}(4) + b$$

$$-1 = -1 + b$$

$$b = 0$$

$$\text{So } y = -\frac{1}{4}x + 0 \text{ or } y = -\frac{1}{4}x$$

9. $m = \frac{2}{3}$ and contains $\left(\frac{1}{2}, 1\right)$

$$1 = \frac{2}{3}\left(\frac{1}{2}\right) + b$$

$$1 = \frac{1}{3} + b$$

$$b = 1 - \frac{1}{3} = \frac{2}{3}$$

$$y = \frac{2}{3}x + \frac{2}{3}$$

10. $m = -1$ and contains $\left(\frac{4}{5}, 0\right)$

$$0 = -1\left(\frac{4}{5}\right) + b$$

$$0 = -\frac{4}{5} + b$$

$$b = \frac{4}{5}$$

$$y = -x + \frac{4}{5}$$

11. $(2, 6)$ and $(5, 0)$

$$m = \frac{6-0}{2-5} = \frac{6}{-3} = -2$$

$$0 = -2(5) + b$$

$$b = 10$$

$$y = -2x + 10$$

12. $(5, -2)$ and $(8, 4)$

$$m = \frac{4-(-2)}{8-5} = \frac{6}{3} = 2$$

$$-2 = 2(5) + b$$

$$b = -2 - 10 = -12$$

$$y = 2x - 12$$

13. (3, 5) and (-3, 0)

$$m = \frac{5-0}{3-(-3)} = \frac{5}{6}$$

$$0 = \frac{5}{6}(-3) + b$$

$$b = \frac{15}{6} = \frac{5}{2}$$

$$y = \frac{5}{6}x + \frac{5}{2}$$

14. $m = -\frac{2}{3}$ and contains (2, -2)

$$-2 = -\frac{2}{3}(2) + b$$

$$b = -2 + \frac{4}{3} = \frac{-6+4}{3} = -\frac{2}{3}$$

$$y = -\frac{2}{3}x - \frac{2}{3}$$

15. $m = -3$ and contains (3, -5)

$$-5 = -3(3) + b$$

$$-5 = -9 + b$$

$$b = 4$$

$$y = -3x + 4$$

16. (10, 15) and (12, 20)

$$m = \frac{20-15}{12-10} = \frac{5}{2}$$

$$15 = \frac{5}{2}(10) + b$$

$$b = b = 15 - \frac{25}{2} = \frac{30-25}{2} = \frac{5}{2}$$

$$y = \frac{5}{2}x + \frac{5}{2}$$

17. The graph passes through (0, 3) and (3, 0). Since the y-intercept is (0, 3), then $b = 3$.

$$m = \frac{3-0}{0-3} = \frac{3}{-3} = -1$$

$$y = -x + 3$$

18. The y-intercept is (0, 4), so $b = 4$. The red triangle shows that the slope is -1 because for each time you go down one, you go to the right one.

$$\text{So, } y = -x + 4$$

19. The y-intercept is (0, -2), so $b = -2$. The red triangle shows that the slope is $\frac{1}{2}$ because for each time you go up one, you go to the right two.

$$\text{So, } y = \frac{1}{2}x - 2$$

20. The y-intercept is (0, -6), so $b = -6$. The line also passes through (1, -2)

$$m = \frac{-2 - (-6)}{1 - 0} = \frac{4}{1} = 4$$

$$\text{So, } y = 4x - 6$$

21. $m = 5$ and $f(0) = -3$

$f(0) = -3$ represents the y-intercept

$$\text{So, } y = 5x - 3$$

22. $m = -2$ and $f(0) = 5$

$f(0) = 5$ represents the y-intercept

$$\text{So, } y = -2x + 5$$

23. $m = -7$ and $f(2) = -1$

$f(2) = -1$ represents the point (2, -1)

$$\text{So, } -1 = -7(2) + b$$

$$b = -1 + 14 = 13$$

$$y = -7x + 13$$

24. $m = \frac{1}{3}$ and $f(-1) = \frac{2}{3}$

$f(-1) = \frac{2}{3}$ represents the point $(-1, \frac{2}{3})$

$$\text{So, } \frac{2}{3} = \frac{1}{3}(-1) + b$$

$$b = \frac{2}{3} + \frac{1}{3} = \frac{3}{3} = 1$$

$$y = \frac{1}{3}x + 1$$

25. $m = 4.2$ and $f(-3) = 7.1$

So, $7.1 = 4.2(-3) + b$

$$b = 7.1 - 12.6 = -5.5$$

$$y = 4.2x - 5.5$$

26. $f\left(\frac{1}{4}\right) = \frac{3}{4}$, $f(0) = \frac{5}{4}$

$$\left(\frac{1}{4}, \frac{3}{4}\right) \text{ and } \left(0, \frac{5}{4}\right)$$

$$b = \frac{5}{4}$$

$$m = \frac{\frac{5}{4} - \frac{3}{4}}{0 - \frac{1}{4}} = \frac{\frac{2}{4}}{-\frac{1}{4}} = \frac{2}{4} \left(-\frac{4}{1}\right) = -2$$

$$y = -2x + \frac{5}{4}$$

27. $f(1.5) = -3$, $f(-1) = 2$

$(1.5, -3)$ and $(-1, 2)$

$$m = \frac{2 - (-3)}{-1 - 1.5} = \frac{5}{-2.5} = -2$$

$$2 = -2(-1) + b$$

$$b = 2 - 2 = 0$$

$$y = -2x + 0 \text{ or } y = -2x$$

28. $f(-1) = 1$ and $f(1) = -1$

$(-1, 1)$ and $(1, -1)$

$$m = \frac{1 - (-1)}{-1 - 1} = \frac{2}{-2} = -1$$

$$-1 = (-1)(1) + b$$

$$b = -1 + 1 = 0$$

$$y = -1x + 0 \text{ or } y = -x$$

29. The initial amount is \$1500 and the payments are \$350 per month, m . Then the equation is $y = 350m + 1500$.

$$1 \text{ year} = 12 \text{ months, so } y = 350(12) + 1500 = \$5700$$

He will spend \$5700 in one year.

30. We are given two points on the line, namely (3, 10) and (11, 14). So, the slope of the line is $m = \frac{14-10}{11-3} = \frac{4}{8} = \frac{1}{2}$.

$$10 = \frac{1}{2}(3) + b$$

$$b = 10 - \frac{3}{2} = \frac{20-3}{2} = \frac{17}{2}$$

$$y = \frac{17}{2}x + \frac{1}{2}$$

The height of the plant when it was planted can be found when $x = 0$.

$$y = \frac{17}{2}(0) + \frac{1}{2} = \frac{1}{2}$$

The plant was a half-inch tall when planted.

31. Two points on the line are (160, 5) and (40, 2). We can find the slope of the line that passes through these two points.

$$m = \frac{2-5}{40-160} = \frac{-3}{-120} = \frac{1}{40}$$

Then we can determine the equation of the line.

$$2 = \frac{1}{40}(40) + b$$

$$b = 2 - 1 = 1$$

$$y = \frac{1}{40}x - 1$$

When $x = 140$, then the length of the spring will be $y = \frac{1}{40}(140) - 1 = 3.5 - 1 = 2.5$ inches.

32. We are given the points (100, 265) and (120, 275), where the first coordinate is the weight, w , and the second coordinate is the distance, d .

$$\text{We can find the slope of the line } m = \frac{275-265}{120-100} = \frac{10}{20} = \frac{1}{2}.$$

Then we can find b :

$$265 = \frac{1}{2}(100) + b$$

$$265 = 50 + b$$

$$b = 265 - 50 = 215$$

$$\text{The equation is } d = \frac{1}{2}w + 215.$$

When $w = 150$, then $d = \frac{1}{2}(150) + 215 = 75 + 215 = 290$ feet.

33. Let $x =$ a number. Then $\frac{1}{3}x = x - 7$

34. The formula for the perimeter of a square is $P = 4s$, where $s =$ the length of one side. So $67 = 4s \rightarrow s = 16.75$ cm.

35. Let $x =$ the number of games they lost. Then the number of games they won is $x + 2$ and the number of games they tied is $x - 3$.

So, we can find the number of games they lost by

$$17 = x + (x + 2) + (x - 3)$$

$$17 = 3x - 1$$

$$18 = 3x$$

$$x = 6$$

They lost 6 games, which means they won $6 + 2 = 8$ games and tied $6 - 3 = 3$ games.

36. $\frac{(30 - 4 + 4 \div 2) \div (21 \div 3)}{2} = \frac{(28) \div (7)}{2} = \frac{4}{2} = 2$

37. The opposite of 16.76 is -16.76 .

38.

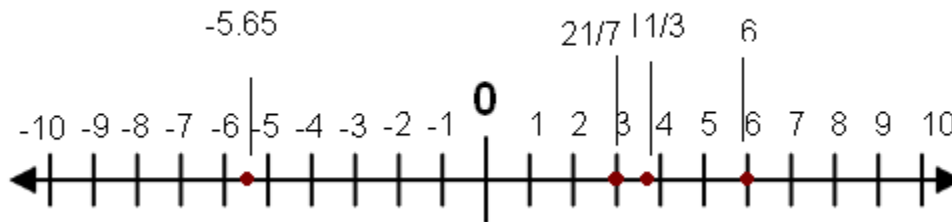

39. $[(-4 + 4.5) + (18 - |-13|) + (-3.3)] = (0.5) + (31) + (-3.3) = 28.2$

Lesson 5.2

- $y - y_1 = m(x - x_1)$
- There are multiple possible answers. One possible answer is that instead of needing to find the y -intercept, you can use any point with the point-slope formula.
- $y = \frac{1}{3}x - 4$
 $y + 4 = \frac{1}{3}x + 0$ OR $y + 4 = \frac{1}{3}x$
- $m = -\frac{1}{10}$ and passes through $(10, 2)$
 $y - 2 = -\frac{1}{10}(x - 10)$ OR $y - 2 = -\frac{1}{10}x + 1$
- $m = -75$ and passes through $(0, 125)$
 $y - 125 = -75(x - 0)$ OR $y - 125 = -75x$
- $m = 10$ and passes through $(8, -2)$
 $y + 2 = 10(x - 8)$ OR $y + 2 = 10x - 80$
- passes through points $(-2, 3)$ and $(-1, -2)$
We must first find the slope of the line.
$$m = \frac{-2 - 3}{-1 - (-2)} = \frac{-5}{1} = -5$$

Then we can select either point to write our equation.
 $y + 2 = -5(x + 1)$ OR $y + 2 = -5x - 5$
- passes through points $(0, 0)$ and $(1, 2)$
We must first find the slope of the line.
$$m = \frac{2 - 0}{1 - 0} = \frac{2}{1} = 2$$

Then we can select either point to write our equation.
 $y - 0 = 2(x - 0)$ OR $y = 2x$

9. passes through points (10, 12) and (5, 25)

We must first find the slope of the line.

$$m = \frac{25-12}{5-10} = \frac{13}{-5} = -\frac{13}{5}$$

Then we can select either point to write our equation.

$$y-12 = -\frac{13}{5}(x-10) \text{ OR } y-12 = -\frac{13}{5}x+26$$

10. passes through points (2, 3) and (0, 3)

We must first find the slope of the line. You may notice that the y-coordinates are the same. That means this is a horizontal line, so the slope should be zero.

$$m = \frac{3-3}{0-2} = \frac{0}{-2} = 0$$

Because the slope is zero, the y-coordinate will always be the same. Therefore, the equations of the line is $y = 3$. Here is the result by following the same process.

Selecting either point to write our equation gives

$$y - 3 = 0(x - 0)$$

$$y - 3 = 0$$

$$y = 3$$

11. $m = \frac{3}{5}$ and y-intercept = -3

We know one point on the line is (0, -3) because those are the coordinates of the

y-intercept. Using the point-slope form, $y+3 = \frac{3}{5}(x-0)$ OR $y+3 = \frac{3}{5}x$.

12. $m = -6$ and y-intercept = 0.5.

Therefore, one point on the line is (0, 0.5).

$$y - 0.5 = -6(x - 0) \text{ OR } y - 0.5 = -6x$$

13. passes through (-4, -2) and (8, 12)

We must first find the slope of the line.

$$m = \frac{12-(-2)}{8-(-4)} = \frac{14}{12} = \frac{7}{6}$$

Then we can select either point to write our equation.

$$y+2 = \frac{7}{6}(x+4) \text{ OR } y+2 = \frac{7}{6}x + \frac{14}{3}$$

14. $y - 2 = 3(x - 1)$

$$y - 2 = 3x - 3$$

$$y = 3x - 1$$

$$15. y + 4 = \frac{-2}{3}(x + 6)$$

$$y + 4 = -\frac{2}{3}x - 4$$

$$y = -\frac{2}{3}x - 8$$

$$16. 0 = x + 5$$

Since there is no y in this equation, it cannot be written in slope-intercept form as usual. Solving for x gives $x = -5$.

$$17. y = \frac{1}{4}(x - 24) \Rightarrow y = \frac{1}{4}x - 6$$

$$18. m = -\frac{1}{5} \text{ and } f(0) = 7. \text{ This tells us one point on the function is } (0, 7).$$

$$y - 7 = -\frac{1}{5}(x - 0)$$

$$y - 7 = -\frac{1}{5}x$$

$$y = -\frac{1}{5}x + 7$$

$$f(x) = -\frac{1}{5}x + 7$$

$$19. m = -12 \text{ and } f(-2) = 5$$

One point on the function is $(-2, 5)$.

$$\text{So } y - 5 = -12(x + 2)$$

$$y - 5 = -12x - 24$$

$$20. f(-7) = 5 \text{ means } (-7, 5) \text{ and } f(3) = -4 \text{ means } (3, -4)$$

$$\text{So, we can find the slope by } m = \frac{-4 - 5}{3 - (-7)} = \frac{-9}{10} = -\frac{9}{10}$$

Now we can use either point to find the equation of the line in point-slope form:

$$y - 5 = -\frac{9}{10}[x - (-7)] \text{ OR } y - 5 = -\frac{9}{10}x - \frac{63}{10}$$

$$21. f(6) = 0 \text{ means } (6, 0) \text{ and } f(0) = 6 \text{ means } (0, 6)$$

$$\text{So, we can find the slope by } m = \frac{6 - 0}{0 - 6} = \frac{6}{-6} = -1$$

Now we can use either point to find the equation of the line in point-slope form:

$$y - 0 = -1(x - 6) \text{ OR } y = -x + 6$$

22. $m = 3$ and $f(2) = -9$

Since we know the slope and a point, we can just substitute the values into the point-slope formula.

$$y - (-9) = 3(x - 2)$$

$$y + 9 = 3x - 6$$

23. $m = -\frac{9}{5}$ and $f(0) = 32$

$$y - 32 = -\frac{9}{5}(x - 0)$$

$$y - 32 = -\frac{9}{5}x$$

24. $m = 25$ and $f(0) = 250$

$$y - 250 = 25(x - 0)$$

$$y - 250 = 25x$$

25. $f(32) = 0$ means $(32, 0)$ and $f(77) = 25$ means $(77, 25)$

So, we can find the slope by $m = \frac{25 - 0}{77 - 32} = \frac{25}{45} = \frac{5}{9}$

Now we can use either point to find the equation of the line in point-slope form:

$$y - 32 = \frac{5}{9}(x - 0) \text{ OR } y - 32 = \frac{5}{9}x$$

26. If we let the independent variable, x , be the weight and the dependent variable, y , be the length of the spring, then we have:

$(100, 20)$ and $(300, 25)$

So, we can find the slope by $m = \frac{25 - 20}{300 - 100} = \frac{5}{200} = \frac{1}{40}$.

$$y - 20 = \frac{1}{40}(x - 100) \text{ OR } y - 32 = \frac{1}{40}x - \frac{5}{2}$$

To find the length of the spring when it is not stretch means to find the value of y when $x = 0$ (when there is no weight on the spring).

$$y - 32 + 32 = \left(\frac{1}{40}x - \frac{5}{2}\right) + 32$$

So, $y = \frac{1}{40}x + \frac{59}{2}$

$$y = \frac{1}{40}(0) + \frac{59}{2} = \frac{59}{2} = 29.5 \text{ cm}$$

27. Let t = time in minutes and d = depth in feet. At the time he decides to go up ($t = 0$), the depth is -400 feet, so one point is $(0, -400)$. He raises up to -50 feet and it takes 20 minutes, which gives us $(20, -50)$.

We can now find the slope of the line the submarine took:

$$m = \frac{-400 - (-50)}{0 - 20} = \frac{-350}{-20} = 17.5$$

$$d + 400 = 17.5(t - 0)$$

$$d + 400 = 17.5t$$

To find the depth after 5 minutes, we need to find d when $t = 5$.

$$\text{Then } d = 17.5(5) - 400 = -312.5.$$

The submarine was at a depth of -312.5 feet.

28. Since she makes \$6 for each sale, it represents the slope.

We know one point on the line is $(200, 2500)$. Therefore we can find the equation of the line.

$$y - 2500 = 6(x - 200) \text{ OR } y - 2500 = 6x - 1200$$

To find the base salary, we need to find the value of y when $x = 0$.

$$y - 2500 = 6(0) - 1200$$

$$y = -1,200 + 2,500 = 1,300$$

Anne's base salary is \$1,300.

29. $4(j + 2) = 400$ translates to 4 times the sum of a number, j , and 2 equals 400.

$$30. 0.45 \cdot 0.25 - 24 \div \frac{1}{4} = 0.1125 - 24 \div \frac{1}{4} = 0.1125 - 6 = -5.8875$$

$$31. C(F) = \frac{F - 32}{1.8}, \text{ so } C(35) = \frac{35 - 32}{1.8} = \frac{3}{1.8} \approx 1.67^\circ \text{C}$$

$$32. \frac{120 \text{ meters}}{3 \text{ minutes}} = 40 \text{ meters/minute}$$

33. What percent of 87.4 is 106?

Let x = the decimal percent

$$x(87.4) = 106 \quad \frac{x(87.4)}{87.4} = \frac{106}{87.4}$$

$$x \approx 1.2128$$

$$1.2128(100) = 121.28\%$$

34. orig = \$25.00 and new = \$40.63

$$\text{amount of change} = 40.63 - 25 = 15.63$$

$$\text{percent change} = \frac{15.63}{25}(100) = 62.52\%$$

$$35. 606 = 0.045(w - 4000) + 0.07w$$

$$606 = 0.045w - 180 + 0.07w$$

$$606 = 0.115w - 180$$

$$\frac{426}{0.115} = \frac{0.115w}{0.115}$$

$$w \approx 3704.35$$

Lesson 5.3

1. $Ax + By = C$, where A , B , and C are integers and A and B are not both zero.
2. "Clear the fractions" means to change the coefficients to integers. To do so, one needs to multiply both sides by a common denominator, usually the lowest common denominator.
3. standard form: $Ax + By = C$
slope-intercept form: $y = \frac{-Ax + C}{B}$ OR $-\frac{A}{B}x + \frac{C}{B}$
Therefore, the slope is $-\frac{A}{B}$ and the y-intercept is $\frac{C}{B}$.
4. $y = 3x - 8$
 $-3x + y = -8$ OR $3x - y = 8$
5. $y = -x - 6$
 $x - y = -8$
6. $y = \frac{5}{3}x - 4$
 $3(y) = \left(\frac{5}{3}x - 4\right)3$
 $3y = 5x - 12$
 $-5x + 3y = -12$ OR $5x - 3y = 12$
7. $0.3x + 0.7y = 15$
To change this to standard form, we must make the coefficients integers. To do this, we need to multiply both sides by 10 since each number is to the tenths place.
 $10(0.3x + 0.7y) = 15(10)$
 $3x + 7y = 150$
8. $5 = \frac{1}{6}x - y$
 $(6)5 = \left(\frac{1}{6}x - y\right)6$
 $30 = x - 6y$
 $x - 6y = 30$

$$\begin{aligned}
 9. \quad y - 7 &= -5(x - 12) \\
 y - 7 &= -5x + 60 \\
 \underline{5x + 7 + 5x + 7} & \\
 5x + y &= 67
 \end{aligned}$$

$$\begin{aligned}
 10. \quad 2y &= 6x + 9 \\
 -6x + 2y &= 9 \text{ OR } 6x - 2y = -9
 \end{aligned}$$

$$\begin{aligned}
 11. \quad y &= \frac{9}{4}x + \frac{1}{4} \\
 4(y) &= \left(\frac{9}{4}x + \frac{1}{4}\right)4 \\
 4y &= 9x + 1 \\
 -9x + 4y &= 1 \text{ OR } 9x - 4y = -1
 \end{aligned}$$

$$\begin{aligned}
 12. \quad y + \frac{3}{5} &= \frac{2}{3}(x - 2) \\
 15\left(y + \frac{3}{5}\right) &= \left[\frac{2}{3}(x - 2)\right]15 \\
 15y + 9 &= 10x - 20 \\
 -10x + 15y - 29 &= 29 \text{ OR } 10x - 15y = 29
 \end{aligned}$$

$$\begin{aligned}
 13. \quad 3y + 5 &= 4(x - 9) \\
 3y + 5 &= 4x - 36 \\
 4x + 3y &= -41
 \end{aligned}$$

$$\begin{aligned}
 14. \quad 5x - 2y &= 15 \\
 \text{First, put the equation in slope-intercept form.} \\
 -2y &= -5x + 15 \\
 y &= \frac{5}{2}x - \frac{15}{2}
 \end{aligned}$$

Now that the equation is in slope-intercept form, we know that the slope is $\frac{5}{2}$ and

the y-intercept is $-\frac{15}{2}$.

15. $3x + 6y = 25$

$$\frac{6y}{6} = \frac{-3x + 25}{6}$$

$$y = -\frac{1}{2}x + \frac{25}{6}$$

slope = $-\frac{1}{2}$ and y-intercept = $\frac{25}{6}$

16. $x - 8y = 12$

$$\frac{-8y}{-8} = \frac{-x + 12}{-8}$$

$$y = \frac{1}{8}x - \frac{3}{2}$$

slope = $\frac{1}{8}$ and y-intercept = $-\frac{3}{2}$

17. $3x - 7y = 20$

$$\frac{-7y}{-7} = \frac{-3x + 20}{-7}$$

$$y = \frac{3}{7}x - \frac{20}{7}$$

slope = $\frac{3}{7}$ and y-intercept = $-\frac{20}{7}$

18. $9x - 9y = 4$

$$\frac{-9y}{-9} = \frac{-9x + 4}{-9}$$

$$y = x - \frac{4}{9}$$

slope = 1 and y-intercept = $-\frac{4}{9}$

19. $6x + y = 3$

$$y = -6x + 3$$

slope = -6 and y-intercept = 3

20. $x - y = 9$

$$\frac{-y}{-1} = \frac{-x + 9}{-1}$$

$$y = x - 9$$

slope = 1 and y-intercept = -9

21. $8x + 3y = 15$

$$\frac{3y}{3} = \frac{-8x+15}{-3}$$

$$y = \frac{8}{3}x - 5$$

slope = $\frac{8}{3}$ and y-intercept = -5

22. $4x + 9y = 1$

$$\frac{9y}{9} = \frac{-4x+1}{9}$$

$$y = -\frac{4}{9}x + \frac{1}{9}$$

slope = $-\frac{4}{9}$ and y-intercept = $\frac{1}{9}$

23. slope = -1 through point $(-3, 5)$

The point-slope formula is $y - y_1 = m(x - x_1)$, so $y - 5 = -1(x + 3)$.

$$y - 5 = -x - 3$$

$$+x + 5 \quad +x + 5$$

Standard Form is $x + y = 2$.

24. slope = $-\frac{1}{4}$ through point $(4, 0)$

$$y - y_1 = m(x - x_1) \rightarrow y - 0 = -\frac{1}{4}(x - 4)$$

$$y = -\frac{1}{4}(x - 4)$$

$$y = -\frac{1}{4}x + 1$$

$$-\frac{1}{4}x + y = 1$$

25. Line through (5, -2) and (-5, 4)

We need to find the slope first. The formula is $m = \frac{y_2 - y_1}{x_2 - x_1}$.

$$m = \frac{y_2 - y_1}{x_2 - x_1} = \frac{4 - (-2)}{-5 - 5} = \frac{6}{-10} = -\frac{3}{5}$$

Then, we can choose any point to substitute into the point-slope formula.

$$y - y_1 = m(x - x_1) \rightarrow y + 2 = -\frac{3}{5}(x - 5)$$

$$y + 2 = -\frac{3}{5}x + 3$$

$$-2 + \frac{3}{5}x \quad -2 + \frac{3}{5}x$$

$$5\left(\frac{3}{5}x + y\right) = 5(1)$$

Standard Form is $3x + 5y = 5$.

26. Line through (-3, -2) and (5, 1)

$$m = \frac{y_2 - y_1}{x_2 - x_1} = \frac{5 - (-2)}{1 - (-3)} = \frac{8}{3}$$

$$y - 1 = \frac{8}{3}x - 1$$

$$+1 - \frac{8}{3}x \quad +1 - \frac{8}{3}x$$

$$-3\left(-\frac{8}{3}x + y\right) = -3(1)$$

Standard Form is $8x - 3y = -3$.

27. Line through (1, -1) and (5, 2)

$$m = \frac{y_2 - y_1}{x_2 - x_1} = \frac{2 - (-1)}{5 - 1} = \frac{3}{4}$$

$$y + 1 = \frac{3}{4}x - 1$$

$$-1 - \frac{3}{4}x \quad -1 - \frac{3}{4}x$$

$$-4\left(-\frac{3}{4}x + y\right) = -4(-2)$$

Standard Form is $3x - 4y = -8$.

28. Let t = the number of pounds of tomatoes and c = the number of pounds of corn.

$$1.29t + 3.25c = 11.61$$

$$\text{If } t = 6, \text{ then } 1.29(6) + 3.25c = 11.61$$

$$7.74 + 3.25c = 11.61$$

$$3.25c = 11.61 - 7.74$$

$$\underline{3.25c = 3.87}$$

$$3.25 \quad 3.25$$

$$c \approx 1.19 \text{ pounds of corn}$$

29. Let f = the number of fried fish plates and b = the number baked fish plates.

$$7.50f + 8.25b = 2,336.25$$

$$\text{If } f = 130, \text{ then } 7.50(130) + 8.25b = 2,336.25$$

$$975 + 8.25b = 2,336.25$$

$$8.25b = 2,336.25 - 975$$

$$\underline{8.25b = 1,361.25}$$

$$8.25 \quad 8.25$$

$$b = 165 \text{ baked fish plates}$$

30. Let j_1 = the number of hours at the job making \$6 per hour and let j_2 = the number of hours at the the job making \$10.

$$\text{Then we can write } 6j_1 + 10j_2 = 366.$$

We need to find the value of j_1 when $j_2 = 15$

$$6j_1 + 10(15) = 366$$

$$6j_1 = 366 - 150$$

$$\underline{6j_1 = 216}$$

$$6 \quad 6$$

$$j_1 = 36$$

Andrew needs to work 36 hours at his \$6 job to meet his goal.

31. First, we need to write the percents as decimals to get the right values, so $5\% = 0.05$ and $7\% = 0.07$. We can assume that the accounts are simple interest. Let a_1 = the amount of money invested in the 5% account and a_2 = the amount of money invested in the 7% account.

Then our equation is $0.05 a_1 + 0.07 a_2 = 400$.

To put the equation in standard form, we need to multiply through by 100.

$$100(0.05a_1 + 0.07a_2) = 100(400)$$

$$5a_1 + 7a_2 = 40,000$$

$$5(5,000) + 7a_2 = 40,000$$

$$25,000 + 7a_2 = 40,000$$

$$7a_2 = 40,000 - 25,000$$

$$\underline{7a_2 = 15,000}$$

$$7 \quad 7$$

$$a_2 = 2,142.86$$

Anne will need to invest no more than \$2,142.86 in the 7% account.

32. $y - 2 = 6(x - 3)$

$$y - 2 = 6x - 18$$

$$y = 6x - 16$$

33. $\frac{p-2}{7} = \frac{p+1}{6}$

$$6(p - 2) = 7(p + 1)$$

$$6p - 12 = 7p + 7$$

$$-19 = p$$

34. The graph of $x = 1.5$ is a vertical line that passes through $x = 1.5$. It is parallel to the y-axis.

35. $5(4) + 3(-3) = 9$

$$20 - 9 = 9$$

$$11 \neq 9$$

It is not a solution to the equation.

36. One point in quadrant III is $(-3, -4)$. All coordinates in quadrant III are negative.

37. $m = \frac{y_2 - y_1}{x_2 - x_1} = \frac{6 - 6}{16 - 6} = \frac{0}{10} = 0$

38.

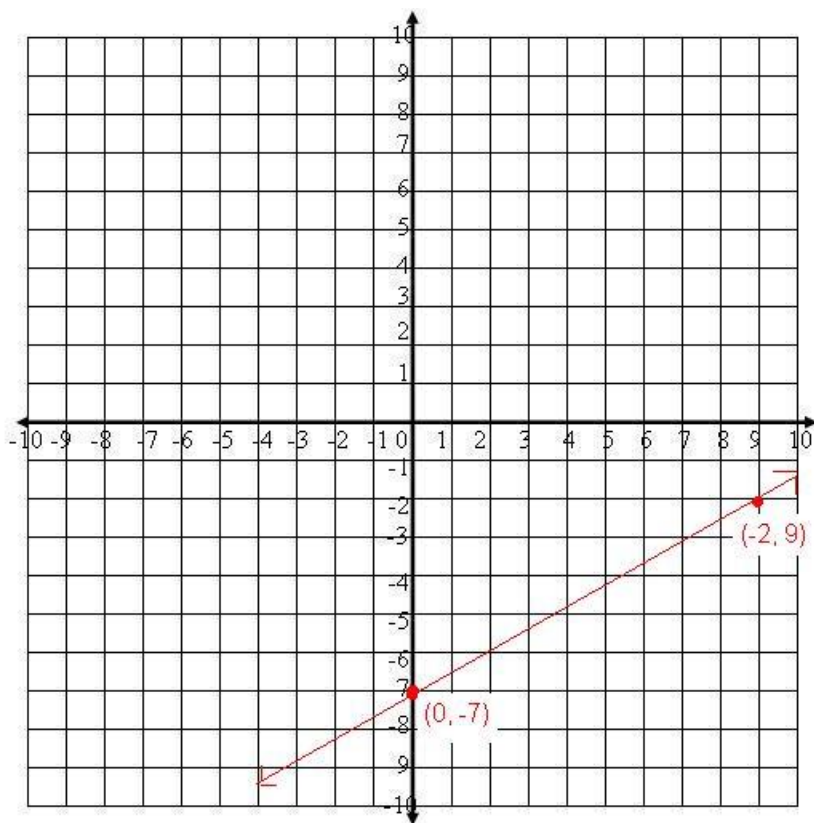

Lesson 5.4

- parallel lines – lines that have the same slope
- perpendicular lines – lines that intersect at 90° angles.
- The product of the slopes of perpendicular lines is -1 .
- A family of lines is a set of lines that have something in common with each other.
- parallel = -5
 - perpendicular = $\frac{1}{5}$
- $2x + 8y = 9$
 $8y = -2x + 9$
 $y = -\frac{1}{4}x + \frac{9}{8}$
 - parallel = $-\frac{1}{4}$
 - perpendicular = 4
- $x = 8$
 - parallel = any vertical line ($x = -2, x = 0, x = 5, \text{ etc}$)
 - perpendicular = any horizontal line ($y = 1, y = 0, y = -7, \text{ etc}$)
- $y = -4.75$
 - parallel = any horizontal line ($y = 1, y = 0, y = -7, \text{ etc}$)
 - perpendicular = any vertical line ($x = -2, x = 0, x = 5, \text{ etc}$)
- $y - 2 = \frac{1}{5}(x + 3)$
 $y - 2 = \frac{1}{5}x + \frac{3}{5}$
 $y = \frac{1}{5}x + \frac{3}{5} + \frac{10}{5}$
 $y = \frac{1}{5}x + \frac{13}{5}$
 - parallel = $\frac{1}{5}$
 - perpendicular = -5
- $m_a = \frac{6-4}{2-(-1)} = \frac{2}{3}$; $m_b = \frac{1-(-3)}{8-2} = \frac{4}{6} = \frac{2}{3}$; lines are parallel

11. $m_a = \frac{0 - (-3)}{-8 - 4} = \frac{3}{-12} = -\frac{1}{4}$; $m_b = \frac{6 - (-1)}{-2 - (-1)} = \frac{7}{-1} = -7$; lines are neither parallel or perpendicular

12. $m_a = \frac{-2 - 14}{1 - (-3)} = \frac{-16}{4} = -4$; $m_b = \frac{5 - (-3)}{-2 - 0} = \frac{8}{-2} = -4$; lines are parallel

13. $m_a = \frac{-3 - 3}{-6 - 3} = \frac{-6}{-9} = \frac{1}{3}$; $m_b = \frac{4 - (-8)}{-6 - 2} = \frac{12}{-8} = -\frac{3}{2}$; lines are neither parallel or perpendicular

14. **Line 1:**

$$4y + x = 8$$

$$4y = -x + 8$$

$$y = -\frac{1}{4}x + 2$$

Line 2:

$$12y + 3x = 1$$

$$12y = -3x + 1$$

$$y = -\frac{1}{4}x + \frac{1}{12}$$

Since they have the same slope, the lines are parallel.

15.

Line 1:

$$5y + 3x = 1$$

$$5y = -3x + 1$$

$$y = -\frac{3}{5}x + \frac{1}{5}$$

Line 2:

$$6y + 10x = -3$$

$$6y = -10x - 3$$

$$y = -\frac{10}{6}x - \frac{3}{6}$$

$$y = -\frac{5}{3}x - \frac{1}{2}$$

The lines are neither parallel nor perpendicular.

16. **Line 1:**

$$2y - 3x + 1 = 0$$

$$2y = 3x - 1$$

$$y = \frac{3}{2}x - \frac{1}{2}$$

Line 2:

$$y + 6x = -3$$

$$y = -6x - 3$$

The lines are neither parallel nor perpendicular.

17. Find the equation of the line parallel to $5x - 2y = 2$ that passes through point $(3, -2)$.

First, we need to find the slope of the given line, so

$$5x - 2y = 2$$

$$-2y = -5x + 2$$

$$y = \frac{5}{2}x - 1$$

The slope of the given line and the new line is $\frac{5}{2}$.

Now we use the point-slope form of a line to find the equation of the new line.

$$y + 2 = \frac{5}{2}(x - 3)$$

$$y + 2 = \frac{5}{2}x - \frac{15}{2}$$

$$y = \frac{5}{2}x - \frac{15}{2} - \frac{4}{2}$$

$$y = \frac{5}{2}x - \frac{19}{2}$$

18. Find the equation of a line perpendicular to $y = -\frac{2}{5}x - 3$ that passes through point $(2, 8)$.

The slope of the given line is $-\frac{2}{5}$, so the slope of a line perpendicular to it is $\frac{5}{2}$.

$$y - 8 = \frac{5}{2}(x - 2)$$

$$y - 8 = \frac{5}{2}x - 5$$

$$y = \frac{5}{2}x - 5 + 8$$

$$y = \frac{5}{2}x + 3$$

19. Find the equation of the line parallel to $7y + 2x - 10 = 0$ that passes through the point $(2, 2)$.

$$7y + 2x = 10$$

$$7y = -2x + 10$$

$$y = -\frac{2}{7}x + \frac{10}{7}$$

A line parallel to the line has a slope of $-\frac{2}{7}$.

$$y - 2 = -\frac{2}{7}(x - 2)$$

$$y - 2 = -\frac{2}{7}x + \frac{4}{7}$$

$$y = -\frac{2}{7}x + \frac{4}{7} + \frac{14}{7}$$

$$y = -\frac{2}{7}x + \frac{18}{7}$$

20. Find the equation of the line perpendicular to $y + 5 = 3(x - 2)$ that passes through the point $(6, 2)$.

$$y + 5 = 3(x - 2)$$

$$y + 5 = 3x - 6$$

$$y = 3x - 11$$

The slope of a line perpendicular to the given line is $-\frac{1}{3}$.

$$y - 2 = -\frac{1}{3}(x - 6)$$

$$y - 2 = -\frac{1}{3}x + 2$$

$$y = -\frac{1}{3}x + 4$$

21. Find the equation of the line through $(2, -4)$ perpendicular to $y = \frac{2}{7}x + 3$.

The slope of a line perpendicular to the given line is $-\frac{7}{2}$.

$$y + 4 = -\frac{7}{2}(x - 2)$$

$$y + 4 = -\frac{7}{2}x + 7$$

$$y = -\frac{7}{2}x + 3$$

22. Find the equation of the line through (2, 3) parallel to $y = \frac{3}{2}x + 5$.

A line parallel to the line has a slope of $\frac{3}{2}$.

$$y - 3 = \frac{3}{2}(x - 2)$$

$$y - 3 = \frac{3}{2}x - 3$$

$$y = \frac{3}{2}x$$

23. All lines pass through point (0, 4).

Therefore, the equation of the family of equations is $y = Ax + 4$, where A is any real number.

24. All lines are perpendicular to $4x + 3y - 1 = 0$.

$$3y = -4x + 1$$

$$y = -\frac{4}{3}x + \frac{1}{3}$$

The slope of any line perpendicular to the given line is $\frac{3}{4}$.

Therefore, the equation of the family of lines perpendicular to the given line is

$$y = \frac{3}{4}x + B, \text{ where } B \text{ where } B \text{ is any real number.}$$

25. All lines are parallel to $y - 3 = 4x + 2$.

$y = 4x + 5$, so the slope of any line parallel to the given line is 4.

Therefore, the equation of the family of lines parallel to the given line is

$y = 4x + B$, where B where B is any real number.

26. All lines pass through point (0, -1).

The y-intercept is -1. Therefore, the equation of the family of equations is

$y = Ax - 1$, where A is any real number.

27. Write an equation for a line parallel to the equation graphed at the right.

The slope of the graphed line is $\frac{1}{2}$. Therefore, the equation of the family of lines

parallel to the given line is $y = \frac{1}{2}x + B$, where B where B is any real number.

28. Write an equation for a line perpendicular to the equation graphed at the right passing through the ordered pair $(0, -1)$.

The slope of any line perpendicular to the given line is -2 . We now know the slope and the y -intercept (-1) . The equation of the line new line is $y = -2x - 1$.

29. $2x - y = 10$
 $-y = -2x + 10$
 $y = 2x - 10$

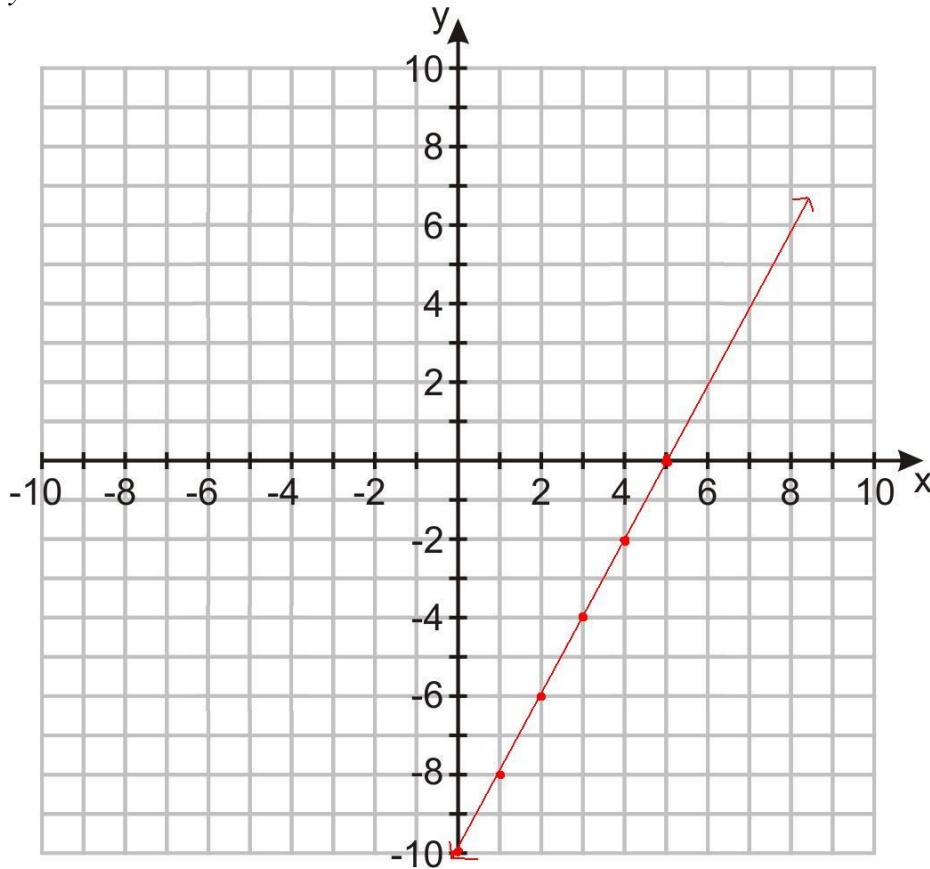

30. $\frac{8 \text{ inches}}{6 \text{ feet}} = \frac{x \text{ inches}}{40 \text{ feet}}$
 $6x = 320$
 $x \approx 53.3 \text{ inches}$

31. $\frac{50 \text{ words}}{\$11.50} = \frac{70 \text{ words}}{\$x}$
 $50x = 805$
 $x = \$16.10$

32. $\sqrt{112} = \sqrt{16(7)} = 4\sqrt{7}$

$$33. \sqrt{12^2 - 7^2} = \sqrt{144 - 49} = \sqrt{95}$$

34. $\sqrt{3} - \sqrt{2} \approx 0.3178372452 \dots$, so the answer is irrational. An irrational number minus another irrational number is irrational.

$$35. 15s = 6(s + 32)$$

$$15s = 6s + 192$$

$$9s = 192$$

$$s = 21\frac{1}{3}$$

Quick Quiz

$$1. y = \frac{4}{3}x + 8$$

$$2. m = \frac{-3-1}{7-6} = \frac{-4}{1} = -4$$

$$y - 1 = -4(x - 6)$$

$$y - 1 = -4x + 24$$

$$y = -4x + 25$$

3. (2.5, 75) and (5, 168.75) are two points on the line.

$$m = \frac{168.75 - 75}{5 - 2.5} = \frac{93.75}{2.5} = 37.5$$

$$y - 75 = 37.5(x - 2.5)$$

$$y - 75 = 37.5x - 93.5$$

$$y = 37.5x - 18.75$$

$$\text{When } x = 1, y = 37.5(1) - 18.75 = 18.75$$

A one-hour job will cost \$18.75.

$$4. y = \frac{6}{5}x + 11$$

$$-\frac{6}{5}x + y = 11$$

$$6x - 5y = -55$$

5. Let s = the number of student tickets and a = the number of adult tickets.

Then we can write $3s + 3.75a = 337.50$.

When $s = 75$,

$$3(75) + 3.75a = 337.50$$

$$225 + 3.75a = 337.50$$

$$3.75a = 112.5$$

$$a = 30$$

Thirty adult tickets were sold.

Lesson 5.5

1. A scatter plot is a relation that represents real data that may be linear or non-linear.
2. line of best fit – a line that best represents the data on a scatter plot.
3. outlier - a data point that does not fit with the general pattern of the data.
4. Two methods for finding the line of best fit –
 - a) use a graphing calculator to plot the points and run the algorithm
 - b) determine the equation of the line using the slope and intercept
5. Draw a line of best fit, then chose two points on the line. Determine the slope and y-intercept of the line. Then write the equation of the line. Since each person may draw a slightly different line, the equations may not be the same.
6. (57, 45) (65, 61) (34, 30) (87, 78) (42, 41) (35, 36) (59, 35) (61, 57) (25, 23) (35, 34)

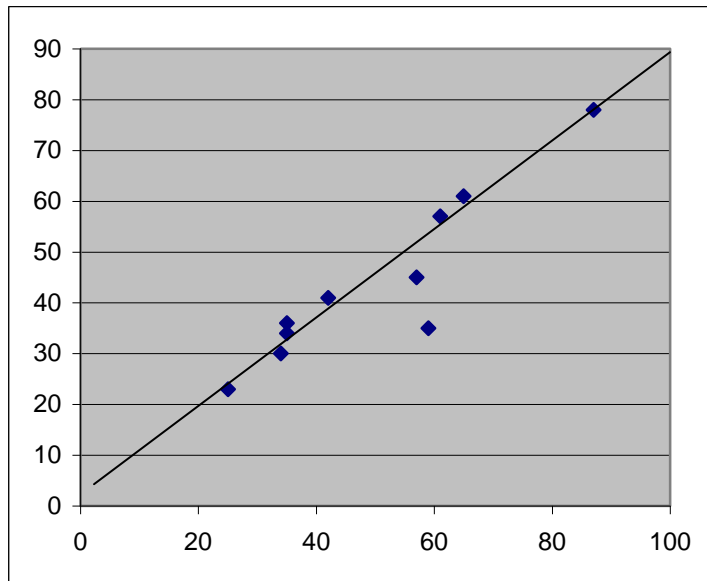

Two points on the line are (25, 23) and (87, 78). The slope of the line is

$$m = \frac{78 - 23}{87 - 25} = \frac{55}{62} \approx 0.887.$$

Then,

$$y - 23 = 0.887(x - 25)$$

$$y - 23 = 0.887x - 22.175$$

$$y = 0.887x + 0.825$$

7. (32, 43) (54, 61) (89, 94) (25, 34) (43, 56) (58, 67) (38, 46) (47, 56) (39, 48)

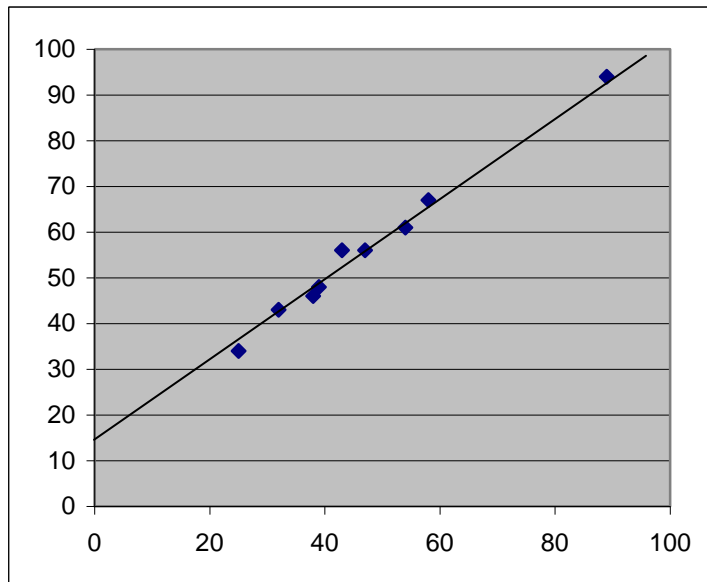

Two points on the line are (38, 46) and (58, 67). The slope of the line is

$$m = \frac{67 - 46}{58 - 38} = \frac{21}{20} = 1.05.$$

Then,

$$y - 46 = 1.05(x - 38)$$

$$y - 46 = 1.05x - 39.9$$

$$y = 0.887x + 6.1$$

8. (12, 18) (5, 24) (15, 16) (11, 19) (9, 12) (7, 13) (6, 17) (12, 14)

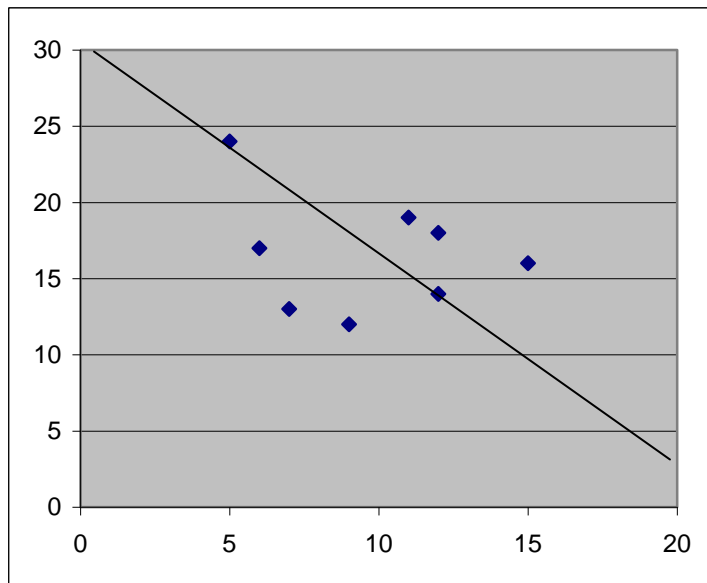

Two points on the line are (5, 24) and (12, 14). The slope of the line is

$$m = \frac{14 - 24}{12 - 5} = \frac{-10}{7} \approx -1.429.$$

Then,

$$y - 14 = -1.429(x - 12)$$

$$y - 14 = -1.429x + 17.148$$

$$y = -1.429x + 31.148$$

9. (3, 12) (8, 20) (1, 7) (10, 23) (5, 18) (8, 24) (2, 10)

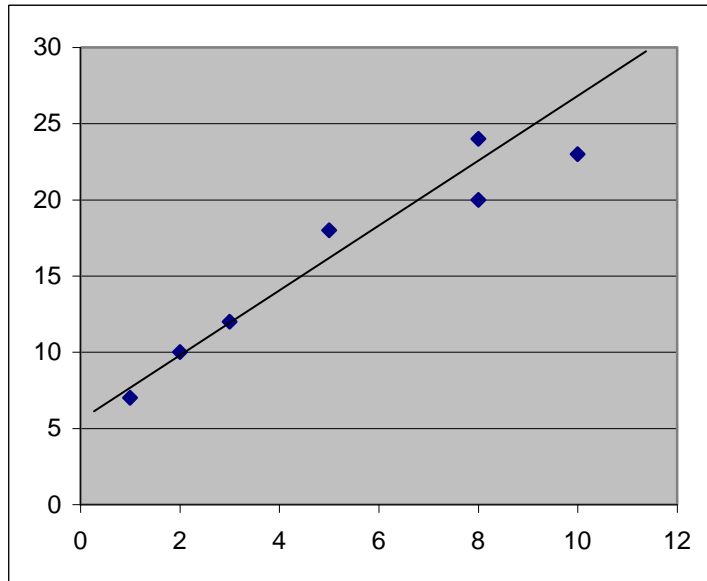

Two points on the line are (2, 10) and (3, 12). The slope of the line is

$$m = \frac{12 - 10}{3 - 2} = \frac{2}{1} = 2.$$

Then,

$$y - 10 = 2(x - 2)$$

$$y - 10 = 2x - 4$$

$$y = 2x + 6$$

10. Use the steps from pages 194 – 196 to plot the points and get the line of best fit.
The equation is $y = 0.8102x + 3.4907$.
11. Use the steps from pages 194 – 196 to plot the points and get the line of best fit.
The equation is $y = 0.9648x + 10.83$.
12. Use the steps from pages 194 – 196 to plot the points and get the line of best fit.
The equation is $y = -0.8041x + 25.033$.

13. (5, 40) and (7, 45)

$$m = \frac{45 - 40}{7 - 5} = \frac{5}{2} = 2.5.$$

Then,

$$y - 40 = 2.5(x - 5)$$

$$y - 40 = 2.5x - 12.5$$

$$y = 2.5x + 27.5$$

The y-intercept means that he could eat 27.5 samosas before he began training.
The slope means that he will increase by 2.5 cookies each day he trains. In two weeks, or when $x = 14$, Shiva will be able to eat $2.5(14) + 27.5 = 62.5$ cookies.

14.

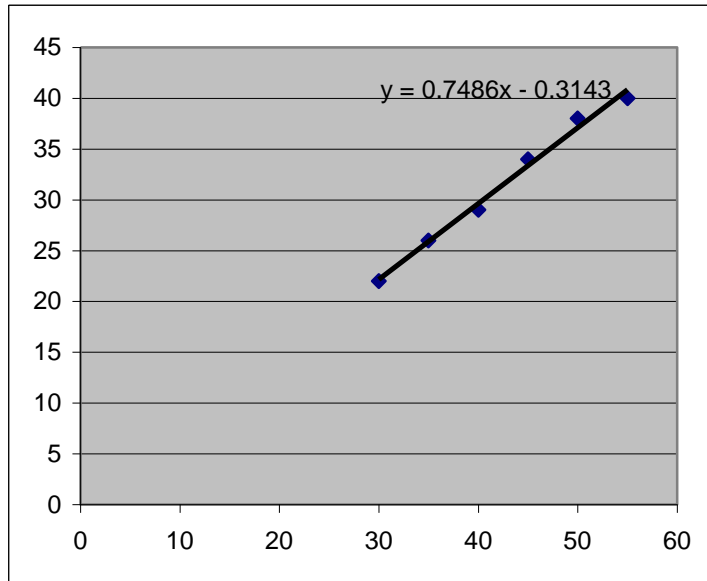

The initial height when the bounce is 65 cm is

$$65 = 0.7486x - 0.3143$$

$$65.3143 = 0.7486x$$

$$x \approx 87.25 \text{ cm}$$

The y-intercept represents the initial height of the ball before it is dropped. The slope represents the speed in which the ball bounces.

15.

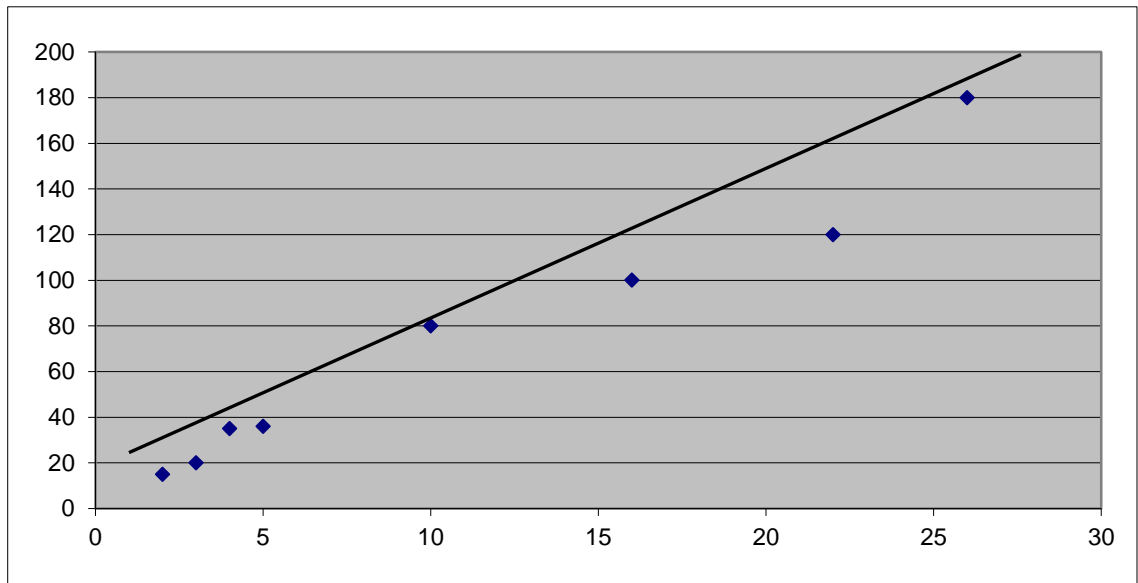

$$y = 6.1196x - 5.9344 \quad (\text{y is time, x is weight of candle})$$

$$95 = 6.1196x - 5.9344$$

$$x \approx 14.55 \text{ oz}$$

16. The first year is 1995, so that is year 0. Then the years are from 0 to 7, where 2002 = 7.

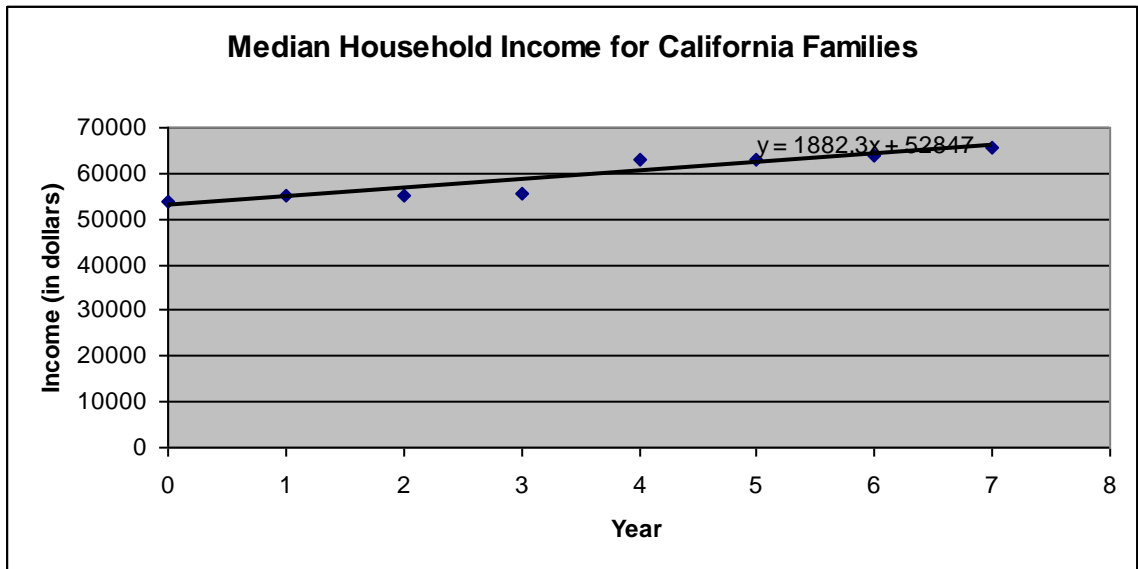

The equation for the line of best fit is $y = 1,882.3x + 52,847$. In 2010 (year = 15), the median income would be about $y = 1,882.3(15) + 52,847 = 81,081.50$, or \$81,081.50. The y-intercept represents the median income in 1995 when the census was complete, and the slope represents the amount the income increased each year.

17. First, the amount of change = $119.64 - 110.27 = 9.37$. We want to know, “What percent of 119.64 is \$9.37?”

Let x = the percent as a decimal.

Then $x(119.64) = 9.37$

$$x = \frac{9.37}{119.64} \approx 0.0783$$

The tax rate was 7.83%.

18. The means are x and 141; the extremes are 4 and 98.

$$19. \frac{4}{x} = \frac{141}{98}$$

$$141x = 392$$

$$x \approx 2.78$$

20. Let t = the number of hours traveled.

$$\frac{328.5 \text{ miles}}{7.3 \text{ hours}} = \frac{82.8 \text{ miles}}{t \text{ hours}}$$

$$328.5t = 604.44$$

$$t = 1.84 \text{ hours}$$

21. When $x = 6,015$, $t(6,015) = 0.85(6,015) = 5,112.75$

Lesson 5.6

1. To interpolate the data means to look for a value in between given data points. It would be helpful when the data skips values along the axes.
2. Extrapolation is making a prediction about data that is either before or after the set of data given. Extrapolation is typically more beneficial with non-linear data sets.
3. The problem with using extrapolation to determine the winning time is that the point trying to be found is too far away from the given set of data.
4. After fitting the line, we see that two of the points on the line is (1927, 12.1) and (1964, 11.2).

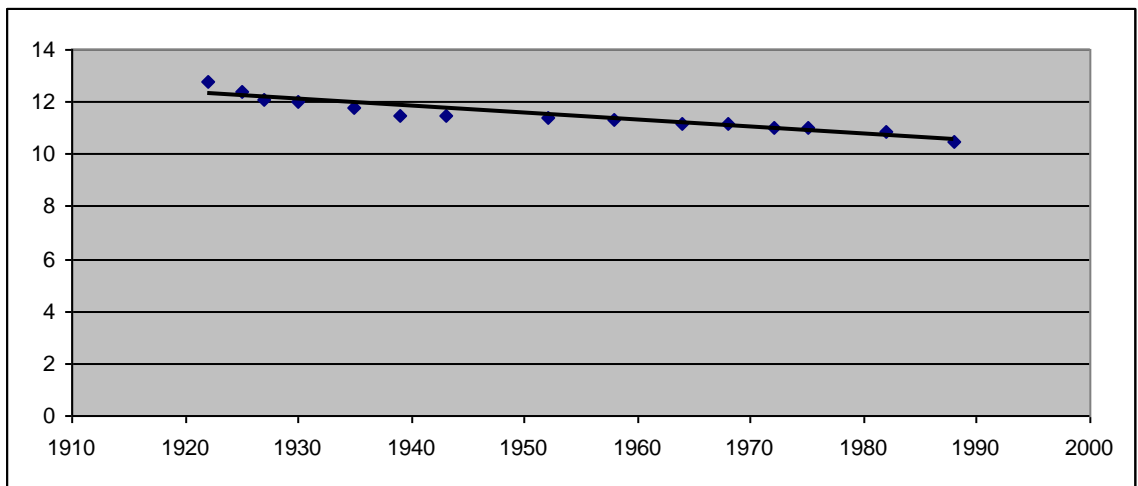

$$m = \frac{11.2 - 12.1}{1964 - 1927} = -\frac{0.9}{37} \approx -0.0243$$

$$y = -0.0243x + b$$

$$11.2 = -0.0243(1964) + b$$

$$b = 143.7$$

$$y = -0.0243x + 58.9$$

5. The points on the line that connect 1940 and 1950 are (1940, 21.5) and (1950, 20.3).

$$m = \frac{20.3 - 21.5}{1950 - 1940} = -\frac{1.2}{10} = -0.12$$

$$y = -0.12x + b$$

$$20.3 = -0.12(1950) + b$$

$$b = 254.3$$

$$y = -0.12x + 254.3$$

Then we can determine the age of marriage for females in 1946.

$$y = -0.12(1946) + 254.3 = 20.78 \approx 20.8 \text{ years}$$

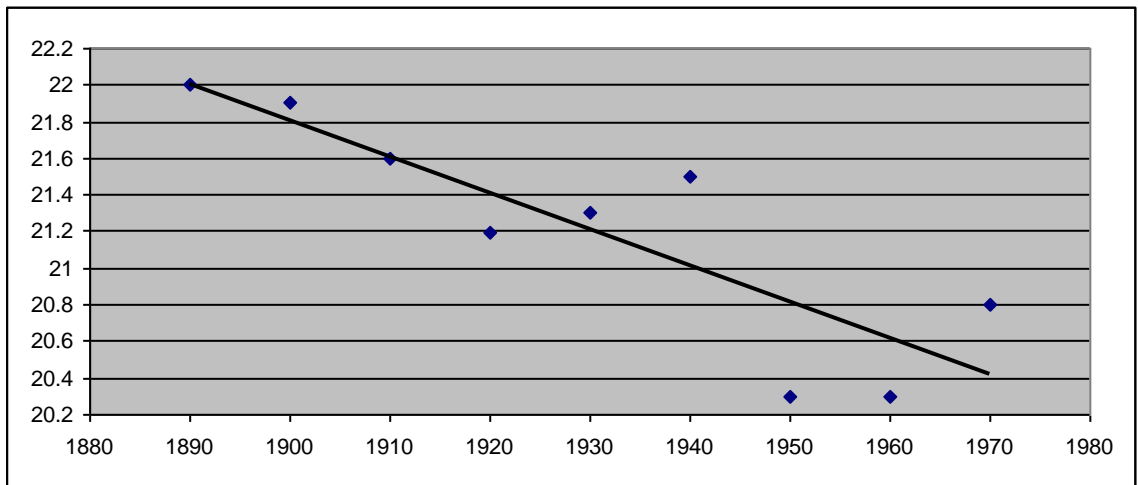

The line of best fit for the data up to 1970 can be found with two points (1890, 22) and (1910, 21.6).

$$m = \frac{22 - 21.6}{1890 - 1910} = -\frac{0.4}{20} = -0.02$$

$$y = -0.02x + b$$

$$22 = -0.02(1890) + b$$

$$b = 59.8$$

$$y = -0.02x + 59.8$$

6. If we use just the points from 1970, the best-fit line does not actually pass through any of the data points. Therefore, is it more difficult to find the best-fit line. This computer-generated scatter plot shows the line of best fit for the data with the equation $y = 0.023x - 24.08$.

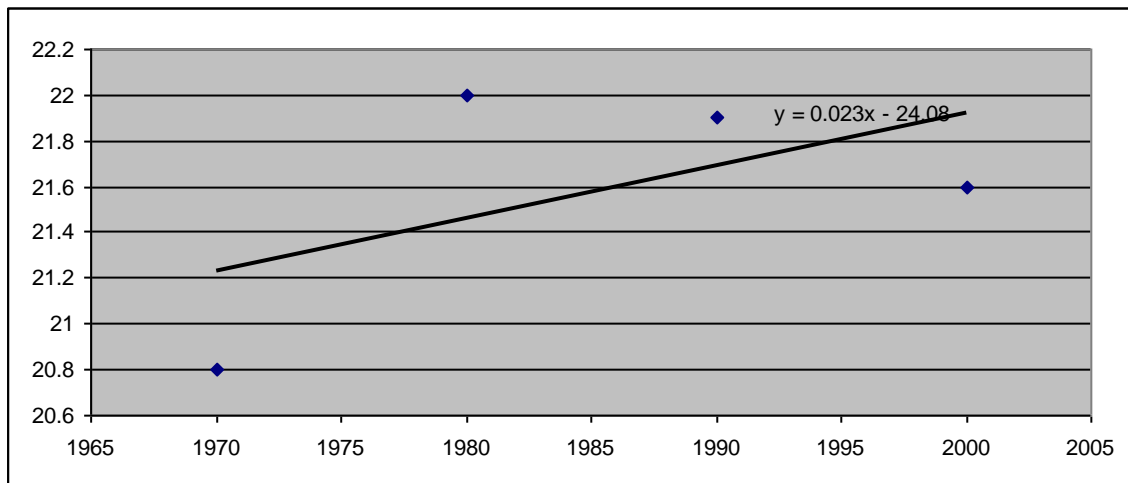

The age of marriage for females in 1984 was $y = 0.023(1984) - 24.08 = 21.552 \approx 21.6$ years.

7. The two points we need are (1990, 26.1) and (2000, 26.8). Then,

$$m = \frac{26.8 - 26.1}{2000 - 1990} = \frac{0.7}{10} = 0.07$$

$$y = 0.07x + b$$

$$26.8 = 0.07(2000) + b$$

$$b = -113.2$$

$$y = 0.07x - 113.2$$

In 1995, males were $y = 0.07(1995) - 113.2 = 26.45 \approx 26.5$ years old.

8. The two points we need are (1996, 13.6) and (2000, 12.2). Then,

$$m = \frac{12.2 - 13.6}{2000 - 1996} = \frac{-1.4}{4} = -0.35$$

$$y = -0.35x + b$$

$$12.2 = -0.35(2000) + b$$

$$b = 712.2$$

$$y = -0.35x + 712.2$$

In 1997, the percent of women smokers were $y = -0.35(1997) + 712.2 = 13.25\%$.

9. The two points we need are (2003, 10.4) and (2004, 10.2). Then,

$$m = \frac{10.2 - 10.4}{2004 - 2003} = \frac{-0.2}{1} = -0.2$$

$$y = -0.2x + b$$

$$10.2 = -0.2(2004) + b$$

$$b = 411$$

$$y = -0.2x + 411$$

In 2006, the percent of women smokers were $y = -0.2(2006) + 411 = 9.8\%$.

10. If we use the years 1922 and 1927, the points we will use are (1927, 12.1) and (1922, 12.8).

$$m = \frac{12.8 - 12.1}{1922 - 1927} = \frac{0.7}{-5} = -0.14$$

$$y = -0.14x + b$$

$$12.8 = -0.14(1922) + b$$

$$b = 281.88$$

$$y = -0.14x + 281.88$$

Then the winning time in 1920 was approximately $y = -0.14(1920) + 281.88 = 13.08$.

11. We will use the points (13, 66) and (13.8, 68).

$$m = \frac{68 - 66}{13.8 - 13} = \frac{2}{0.8} = 2.5$$

$$y = 2.5x + b$$

$$68 = 2.5(13.8) + b$$

$$b = 33.5$$

$$y = 2.5x + 33.5$$

Then we need to know the value of y when $x = 13.2$.

$$y = 2.5(13.2) + 33.5 = 66.5 \text{ degrees}$$

12. We will use the points (10.25, 60) and (11.0, 62).

$$m = \frac{62 - 60}{11.0 - 10.25} = \frac{2}{0.75} \approx 2.67$$

$$y = 2.67x + b$$

$$62 = 2.67(11.0) + b$$

$$b = 27.5$$

$$y = 2.67x + 27.5$$

Then we need to know the value of y when $x = 9$.

$$y = 2.67(9) + 27.5 = 51.53 \text{ degrees}$$

Using Excel, the best-fit line is $y = 1.9491x + 39.964$. So when $x = 9$,

$$y = 1.9491(9) + 39.964 \approx 57.5 \text{ degrees.}$$

The estimate using extrapolation is not very accurate.

Lesson 5.7

A mathematical model allows us to use data to try to represent real-life scenarios. We can make predictions from the data that should reflect what might happen in the real world.

1. Linear modeling refers to scenarios that fit into a linear equation. The data must be somewhat linear in order to use a linear model.
2. We will use points (16, 17.1) and (18, 12.9).

$$m = \frac{12.9 - 17.1}{18 - 16} = \frac{-4.2}{2} \approx -2.1$$

$$y = -2.1x + b$$

$$12.9 = -2.1(18) + b$$

$$b = 50.7$$

$$y = -2.1x + 50.7$$

Then we need to know the value of y when $x = 17$.

$$y = -2.1(17) + 50.7 = 15$$

The height of the water at 17 seconds was 15 centimeters.

3. The best-fit line is $y = 0.2395x - 400.9$

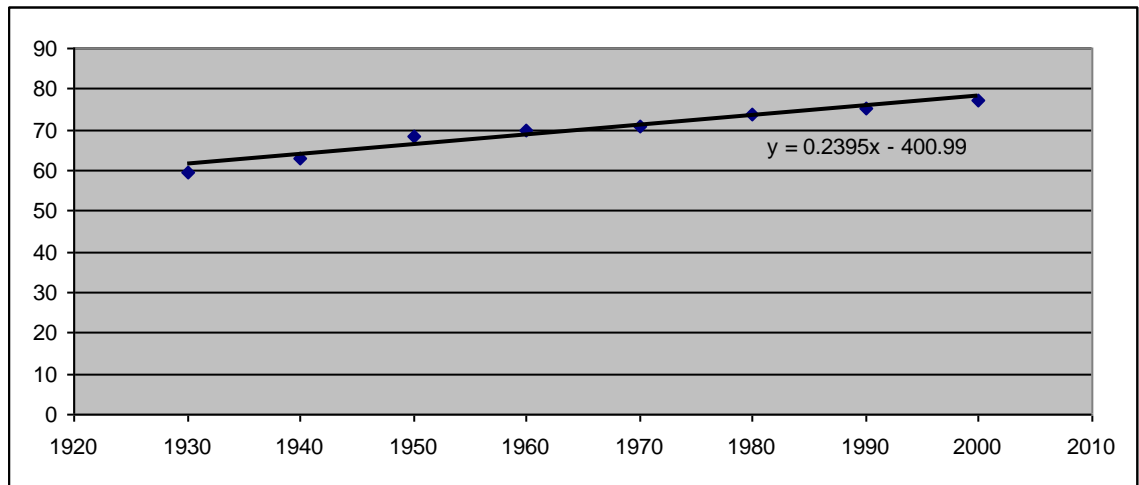

4. When $x = 1955$, $y = 0.2395(1955) - 400.9 \approx 67.2$ years.

5. Using interpolation, we will use points (1950, 68.2) and (1960, 69.7). Then,

$$m = \frac{69.7 - 68.2}{1960 - 1950} = \frac{1.5}{10} = 0.15$$

$$y = 0.5x + b$$

$$68.2 = 0.5(1950) + b$$

$$b = -906.8$$

$$y = 0.5x - 906.8$$

Then we need to know the value of y when $x = 1955$.

$$y = 0.5(1955) - 906.8 = 70.7 \text{ years}$$

6. When $x = 1976$, $y = 0.2395(1976) - 400.9 \approx 72.4$ years.

7. Using interpolation, we will use points (1970, 70.8) and (1980, 73.7). Then,

$$m = \frac{73.7 - 70.8}{1980 - 1970} = \frac{2.9}{10} = 0.29$$

$$y = 0.29x + b$$

$$73.7 = 0.29(1980) + b$$

$$b = -500.5$$

$$y = 0.29x - 500.5$$

Then we need to know the value of y when $x = 1976$.

$$y = 0.29(1976) - 500.5 = 72.5 \text{ years}$$

8. When $x = 2012$, $y = 0.2395(2012) - 400.9 \approx 81.0$ years.

9. Using interpolation, we will use points (1990, 75.4) and (2000, 77). Then,

$$m = \frac{77 - 75.4}{2000 - 1990} = \frac{1.6}{10} = 0.16$$

$$y = 0.16x + b$$

$$77 = 0.16(2000) + b$$

$$b = -243$$

$$y = 0.16x - 243$$

Then we need to know the value of y when $x = 2012$.

$$y = 0.16(2012) - 243 = 78.9 \text{ years}$$

10. The better estimates are the interpolations because the values are more closely aligned with the wanted values.

11.

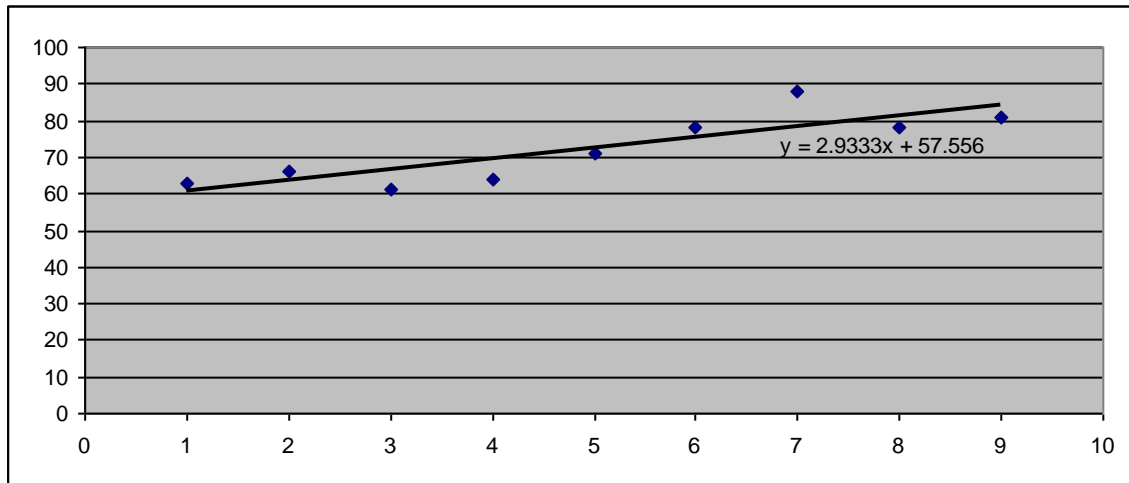

12. When $x = 4.5$, $y = 2.9333(4.5) + 57.556 = 70.8$ degrees.

13. Using interpolation, we will use points (4, 64) and (5, 71). Then,

$$m = \frac{71 - 64}{5 - 4} = \frac{7}{1} = 7$$

$$y = 7x + b$$

$$71 = 7(5) + b$$

$$b = 36$$

$$y = 7x + 36$$

Then we need to know the value of y when $x = 4.5$.

$$y = 7(4.5) + 36 = 67.5 \text{ degrees}$$

14. When $x = 13$, $y = 2.9333(13) + 57.556 = 95.7$ degrees.

15. Using interpolation, we will use points (8, 78) and (9, 81). Then,

$$m = \frac{81 - 78}{9 - 8} = \frac{3}{1} = 3$$

$$y = 3x + b$$

$$81 = 3(9) + b$$

$$b = 54$$

$$y = 3x + 54$$

Then we need to know the value of y when $x = 13$.

$$y = 3(13) + 54 = 93 \text{ degrees}$$

16. The interpolation is a better estimate because the values are more closely aligned with the wanted values.

$$17. 6t(-2 + 7t) - t(4 + 3t) = -12t + 42t^2 - 4t - 3t^2 = 39t^2 - 16t$$

$$18. \frac{119}{8} = \frac{-10}{3} \left(y + \frac{7}{5} \right) - \frac{5}{2}$$

$$120 \left[\frac{119}{8} \right] = \left[\frac{-10}{3} \left(y + \frac{7}{5} \right) - \frac{5}{2} \right] 120$$

$$1785 = -400y - 56 - 300$$

$$1785 = -400y - 356$$

$$2141 = -400y$$

$$y = -5.3525$$

19. $45(1.15) = \$51.75$. With sales tax, the total price is $51.75(1.08) = \$55.89$.

$$20. 0.096 = \frac{96}{1,000} = \frac{12}{125}$$

21. This is direct variation because as one variable increases (or decreases), so will the other variable.

22. (a)

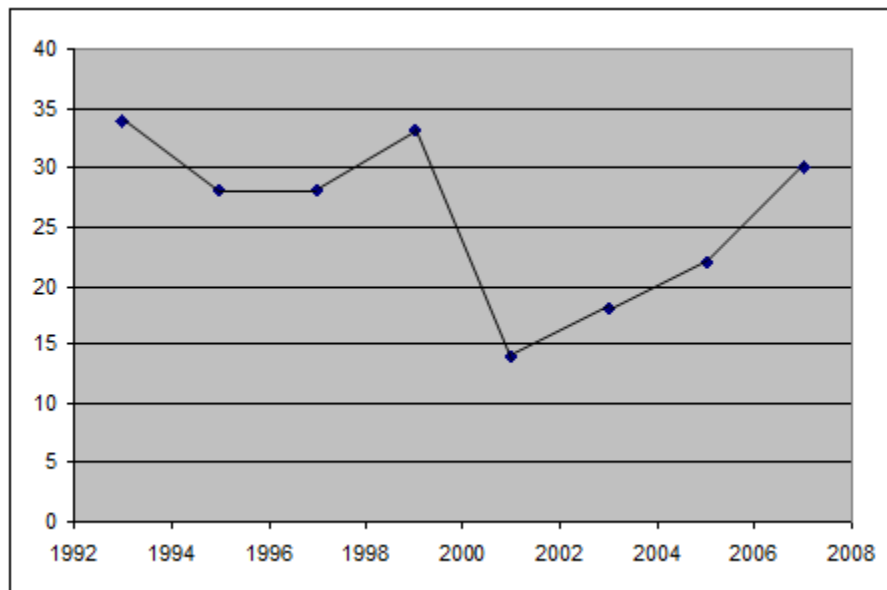

(b) There was a large decrease right before the turn of the century, but that number has steadily increased since.

(c) People might have been excited to see the new millennium, or the economy might have been doing really well during that period.

(d) In 2009, there will be approximately 35 – 40 homicides.

Lesson 5.8

1. This is false. Dimensional analysis does study space and time, but also could cover many other types of dimensions.
2. Identical units that are diagonal cancel out.
3. There are 5,280 feet in a mile.
4. $\frac{12 \text{ inches}}{1 \text{ foot}} \left(\frac{5,280 \text{ feet}}{1 \text{ mile}} \right) = 63,360 \text{ inches in 1 mile}$
5. $\frac{24 \text{ hours}}{1 \text{ day}} \left(\frac{3,600 \text{ seconds}}{1 \text{ hour}} \right) = 86,400 \text{ seconds in 1 day}$
6. $\frac{365 \text{ days}}{1 \text{ year}} \left(\frac{24 \text{ hours}}{1 \text{ day}} \right) \left(\frac{3,600 \text{ seconds}}{1 \text{ hour}} \right) = 31,536,000 \text{ seconds in 1 year}$
7. There are 660 feet in 1 furlong.
8. $\frac{12 \text{ inches}}{1 \text{ foot}} \left(\frac{3 \text{ feet}}{1 \text{ yard}} \right) 100 \text{ yards} = 3,600 \text{ inches in 100 yards}$
9. $\left(\frac{2.54 \text{ centimeters}}{1 \text{ inch}} \right) 5 \text{ inches} = 12.7 \text{ centimeters in 5 inches}$
10. $\left(\frac{1 \text{ meter}}{3.281 \text{ feet}} \right) 90 \text{ feet} \approx 27.43 \text{ meters}$
11. $\left(\frac{1 \text{ meter}}{3.281 \text{ feet}} \right) \left(\frac{3 \text{ feet}}{1 \text{ yard}} \right) 16 \text{ yards} \approx 14.63 \text{ meters}$
12. $\left(\frac{4.23 \text{ cups}}{1 \text{ liter}} \right) 6 \text{ liters} \approx 25.38 \text{ cups}$
13. There are approximately 1.80 cubic inches in 1 ounce.
14. There are approximately 29.57 milliliters in 1 ounce, so
 $\left(\frac{29.57 \text{ milliliters}}{1 \text{ ounce}} \right) 8 \text{ ounces} \approx 236.56 \text{ milliliters}$

15. There are approximately 28.34 grams in 1 ounce.

$$\left(\frac{28.34 \text{ grams}}{1 \text{ ounce}}\right)\left(\frac{16 \text{ ounces}}{1 \text{ pound}}\right)100 \text{ pounds} \approx 45,344 \text{ grams}$$

$$16. \left(\frac{15.432 \text{ grains}}{1 \text{ gram}}\right)25 \text{ grams} = 385.8 \text{ grains}$$

$$17. \left(\frac{68 \text{ beats}}{1 \text{ minute}}\right)\left(\frac{60 \text{ minutes}}{1 \text{ hour}}\right) = 4,080 \text{ beats per hour}$$

$$18. \left(\frac{1 \text{ fathom}}{6 \text{ feet}}\right)\left(\frac{5,280 \text{ feet}}{1 \text{ mile}}\right)6.2 \text{ miles} = 5,456 \text{ fathoms}$$

$$19. \left(\frac{\$1.47}{1 \text{ Pound sterling}}\right)\left(\frac{3.875 \text{ litres}}{1 \text{ gallon}}\right)\left(\frac{96.4 \text{ Pounds sterling}}{1 \text{ litre}}\right) = \$549.12/\text{gallon}$$

$$20. \left(\frac{186,000 \text{ miles}}{1 \text{ second}}\right)\left(\frac{3600 \text{ seconds}}{1 \text{ hour}}\right)\left(\frac{24 \text{ hours}}{1 \text{ day}}\right)\left(\frac{365 \text{ days}}{1 \text{ year}}\right) \approx 5.8657 \times 10^{12} \text{ miles/year}$$

$$21. \left(\frac{63,240 \text{ AU}}{1 \text{ light-year}}\right)4.32 \text{ light-years} = 273,196.8 \text{ AU}$$

$$22. \left(\frac{43,560 \text{ square feet}}{1 \text{ acre}}\right)16 \text{ acres} = 696,960 \text{ square feet}$$

$$23. \left(\frac{1 \text{ kilogram}}{2.205 \text{ pounds}}\right)264 \text{ pounds} \approx 119.728 \text{ kilograms}$$

$$24. \left(\frac{65 \text{ miles}}{1 \text{ hour}}\right)\left(\frac{1.609344 \text{ kilometers}}{1 \text{ mile}}\right) \approx 104.607 \text{ km/hr}$$

$$25. \left(\frac{1.805 \text{ cubic inches}}{1 \text{ ounce}}\right)32 \text{ ounces} \approx 57.76 \text{ cubic inches}$$

$$26. \left(\frac{28,000 \text{ miles}}{1 \text{ hour}}\right)\left(\frac{1 \text{ hour}}{3600 \text{ seconds}}\right)\left(\frac{5,280 \text{ feet}}{1 \text{ mile}}\right) \approx 41,066.7 \text{ feet/second}$$

$$27. \left(\frac{14 \text{ days}}{1 \text{ fortnight}} \right) \left(\frac{24 \text{ hours}}{1 \text{ day}} \right) = 336 \text{ hours in a fortnight}$$

$$28. \left(\frac{1 \text{ fortnight}}{14 \text{ days}} \right) \left(\frac{365 \text{ days}}{1 \text{ year}} \right) 2 \text{ years} \approx 52.14 \text{ fortnights in 2 years}$$

$$29. 32,000 \text{ pounds} \left(\frac{1 \text{ ton}}{2,000 \text{ pounds}} \right) = 16 \text{ tons}$$

$$30. \text{Volume of a 2-liter bottle in pints} = 2 \text{ liters} \left(\frac{1.06 \text{ quarts}}{1 \text{ liter}} \right) \left(\frac{2 \text{ pints}}{1 \text{ quart}} \right) = 4.24 \text{ pints}$$

$$\text{Volume of 1 gallon of water in pints} = 1 \text{ gallon} \left(\frac{8 \text{ pints}}{1 \text{ gallon}} \right) = 8 \text{ pints}$$

The human blood has the greatest volume.

$$31. -2x + 8 = 8(1 - 4x)$$

$$-2x + 8 = 8 - 32x$$

$$\frac{30x}{30} = \frac{0}{30}$$

$$x = 0$$

$$32. 3 - 2(5 - 8h) + 13h \cdot 3$$

$$3 - 10 + 16h + 39h$$

$$-7 + 55h$$

$$33. -26.375 - \left(-14\frac{1}{8} \right) = -26.375 + 14.125 = -12.25$$

$$34. -2\frac{3}{7} \cdot \frac{9}{10} = -\frac{17}{7} \cdot \frac{9}{10} = -\frac{153}{70} \text{ OR } -2\frac{13}{70}$$

$$35. \sqrt{80} = \sqrt{16 \cdot 5} = 4\sqrt{5}$$

36. This number is not irrational because it is a repeating decimal. By definition, irrational numbers do not end or repeat.

37. The domain is $\{0, 1, 2, 3, 4, 5\}$.

38. The range is $\left\{ \frac{1}{4}, \frac{1}{2}, 1, 2, 4, 8 \right\}$.

39. The relation is a function.

40. The pattern is that for each increase of one in the domain, the range is halved.

Lesson 5.9 Chapter 5 Review

1. $y - y_1 = m(x - x_1)$

$$y - 4 = \frac{2}{3}(x - 3)$$

$$y - 4 = \frac{2}{3}x - 2$$

$$+ 4 \quad + 4$$

$$y = \frac{2}{3}x + 2$$

2. $y = -5x + 9$

3. $y - y_1 = m(x - x_1)$

$$y - 0 = -1(x - 6)$$

$$y = -x + 6$$

4. $m = \frac{6-1}{9-3.5} = \frac{5}{6.5} \approx 0.77$

$$y - y_1 = m(x - x_1)$$

$$y - 6 = 0.77(x - 9)$$

$$y - 6 = 0.77x - 6.93$$

$$y = 0.77x - 0.93$$

5. $y = 3x - 1$

6. $y + 4 = -\frac{1}{3}(x + 3)$

$$y + 4 = -\frac{1}{3}x - 3$$

$$y + 4 = -\frac{1}{3}x - 7$$

7. $m = \frac{-8-0}{9-0} = \frac{-8}{9} = -\frac{8}{9}$

$$y - y_1 = m(x - x_1)$$

$$y = -\frac{8}{9}x$$

8. $y = \frac{5}{3}x + 6$

$$9. \quad m = \frac{-3-2}{-6-5} = \frac{-5}{-11} = \frac{5}{11}$$

$$y - y_1 = m(x - x_1)$$

$$y - 2 = \frac{5}{11}x - 5$$

$$y = \frac{5}{11}x - 3$$

10. $f(6) = 1$ means the function passes through $(6, 1)$

Therefore, $y - y_1 = m(x - x_1)$ becomes $y - 1 = 3(x - 6)$.

$$y - 1 = 3x - 18$$

$$y = 3x - 17$$

11. Two points on the function are $(2, -5)$ and $(-6, 3)$.

$$m = \frac{3 - (-5)}{-6 - 2} = \frac{8}{-8} = -1$$

$$y - y_1 = m(x - x_1)$$

$$y - 3 = -1(x + 6)$$

$$y - 3 = -x - 6$$

$$y = -x + 3$$

12. $f(1) = 1$ means one point on the function is $(1, 1)$.

Then $y - y_1 = m(x - x_1)$ becomes

$$y - 1 = \frac{3}{8}(x - 1)$$

$$y - 1 = \frac{3}{8}x - \frac{3}{8}$$

$$y = \frac{3}{8}x - \frac{3}{8} + \frac{8}{8}$$

$$y = \frac{3}{8}x + \frac{5}{8}$$

13. $y - y_1 = m(x - x_1)$

$$14. y - y_1 = m(x - x_1)$$

$$y - 5 = \frac{1}{2}(x + 7)$$

$$y - 5 = \frac{1}{2}x + \frac{7}{2}$$

$$y = \frac{1}{2}x + \frac{7}{2} + \frac{10}{2}$$

$$y = \frac{1}{2}x + \frac{17}{2}$$

$$15. y - y_1 = m(x - x_1)$$

$$y - 0 = 2(x - 7)$$

$$y = 2x - 14$$

$$16. y + 3 = -(x - 2)$$

$$y + 3 = -x + 2$$

$$y = -x - 1$$

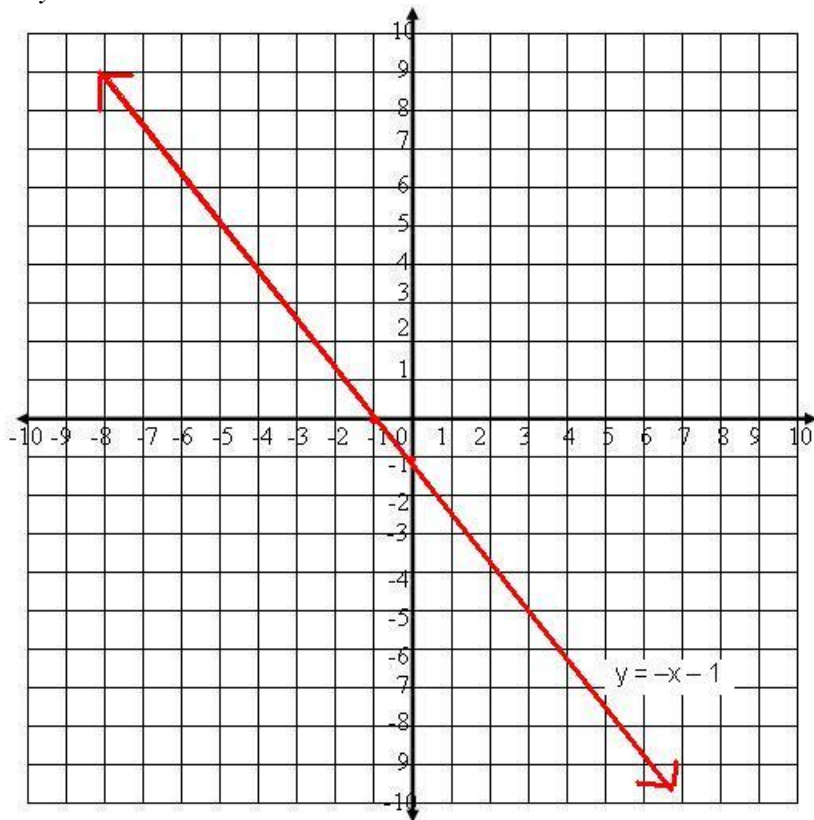

$$17. y - 7 = \frac{-2}{3}(x + 5)$$

$$y - 7 = -\frac{2}{3}x - \frac{10}{3}$$

$$y = -\frac{2}{3}x - \frac{10}{3} + \frac{21}{3}$$

$$y = -\frac{2}{3}x + \frac{11}{3}$$

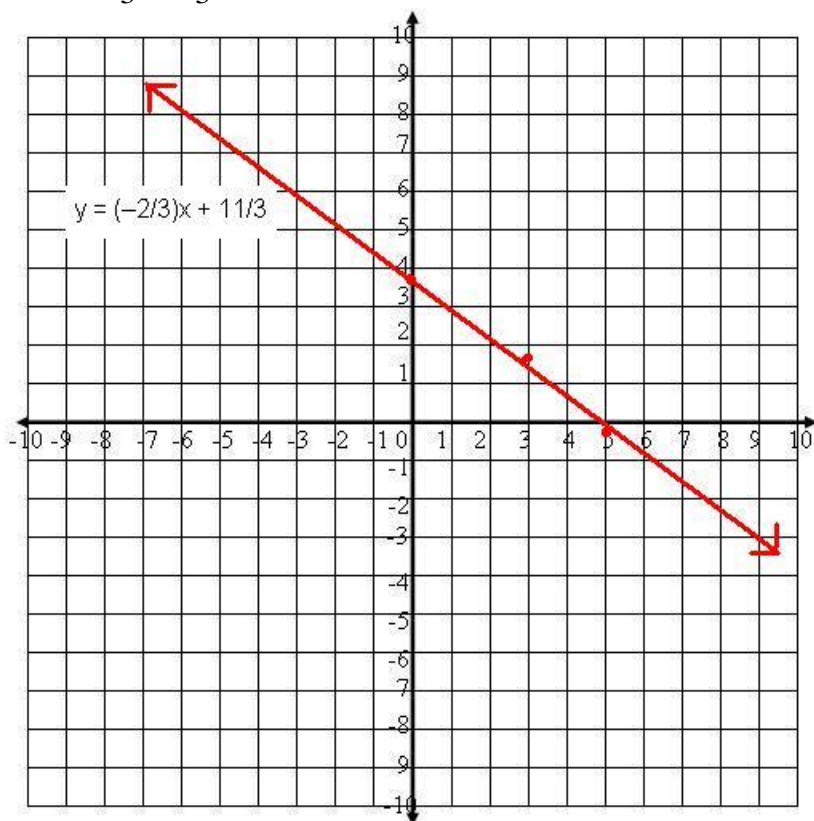

$$18. y + 1.5 = \frac{3}{2}(x + 4)$$

$$y + 1.5 = \frac{3}{2}x + \frac{12}{2}$$

$$y = \frac{3}{2}x + \frac{12}{2} - \frac{3}{2}$$

$$y = \frac{3}{2}x + \frac{9}{2}$$

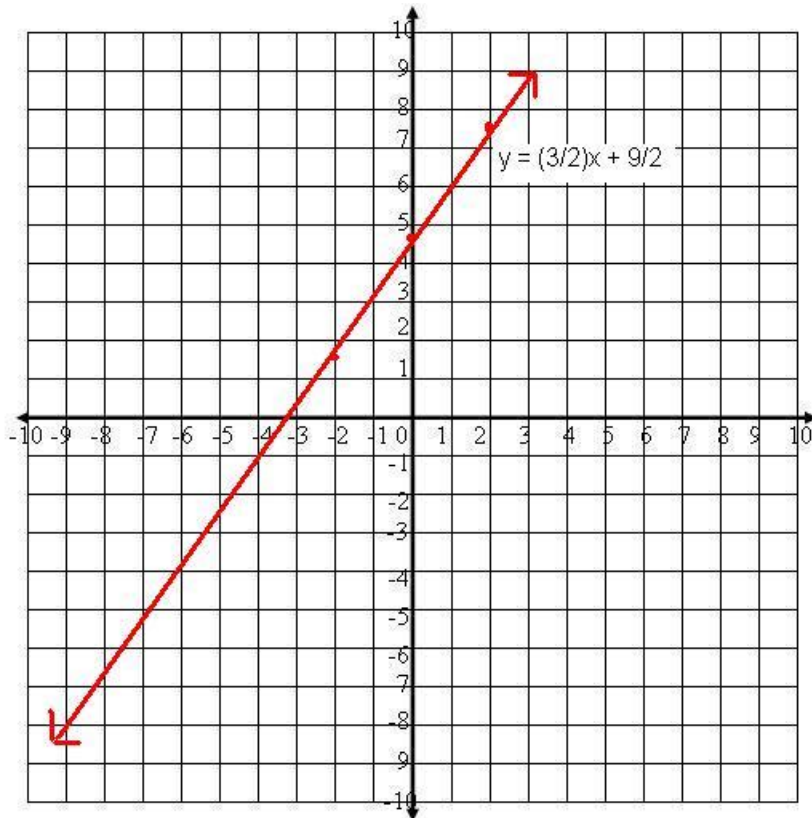

19. Two points on the line are $(1, -3)$ and $(6, 0)$.

$$m = \frac{0 - (-3)}{6 - 1} = \frac{3}{5}$$

$$y - y_1 = m(x - x_1)$$

$$y - 0 = \frac{3}{5}(x - 6)$$

$$y = \frac{3}{5}x - \frac{18}{5}$$

20. Two points on the line are (9, 2) and (9, -5).

$$m = \frac{-5-2}{9-9} = \frac{-7}{0} = \text{undefined}$$

Since the slope is undefined, that means the x -value is always the same.

Therefore, the equation is $x = 9$.

21. One point on the line is (2, 0), and the slope is $\frac{8}{3}$.

$$y - y_1 = m(x - x_1)$$

$$y - 0 = \frac{8}{3}(x - 2)$$

$$y = \frac{8}{3}x - \frac{16}{3}$$

22. $y - 3 = \frac{-1}{4}(x + 4)$

$$y - 3 = -\frac{1}{4}x - 1$$

$$4(y - 3) = 4\left(-\frac{1}{4}x - 1\right)$$

$$4y - 12 = -1x - 4$$

$$x + 4y = 8$$

23. $y = \frac{2}{7}(x - 21)$

$$7(y) = 7\left[\frac{2}{7}(x - 21)\right]$$

$$7y = 2x - 42$$

$$-2x + 7y = -42$$

$$2x - 7y = 42$$

24. $-3x - 25 = 5y$

$$3x + 5y = -25$$

25. Two points on the line are (0, -4) and (-1, 5).

$$m = \frac{5 - (-4)}{-1 - 0} = \frac{9}{-1} = -9$$

$$y - y_1 = m(x - x_1)$$

$$y + 4 = -9(x - 0)$$

$$y = -9x - 4$$

$$9x + y = -4$$

26. $y - y_1 = m(x - x_1)$

$$y - 2 = \frac{4}{3}(x - 3)$$

$$3(y - 2) = 3\left(\frac{4}{3}x - 4\right)$$

$$3y - 6 = 4x - 12$$

$$4x - 3y = 6$$

27. The slope is 5, and the line passes through (5, 0).

$$y - y_1 = m(x - x_1)$$

$$y - 0 = 5(x - 5)$$

$$y = 5x - 25$$

$$25 = 5x - y$$

$$5x - y = 25$$

28. $7x + 5y = 16$

$$5y = -7x + 16$$

$$y = \frac{-7x + 16}{5} = -\frac{7}{5}x + \frac{16}{5}$$

$$\text{Slope} = -\frac{7}{5}; \text{y-intercept} = \frac{16}{5}$$

29. $7x - 7y = -14$

$$-7y = -7x - 14$$

$$y = \frac{-7x - 14}{-7} = x + 2$$

$$\text{Slope} = 1; \text{y-intercept} = 2$$

30. To determine if the lines are parallel or perpendicular, we need to find the slope of each line.

$$\frac{1}{2}x + \frac{1}{2}y = 5$$

$$\frac{1}{2}y = -\frac{1}{2}x + 5$$

$$y = -x + 10$$

The slope of this line is -1 .

$$2x + 2y = 3$$

$$2y = -2x + 3$$

$$y = -x + \frac{3}{2}$$

The slope of the second line is -1 . Since the lines have the same slope, the lines are parallel.

31. Since $x = 4$ is a vertical line, and $y = -2$ is horizontal, then the lines are perpendicular.

32. $2x + 8y = 26$

$$8y = -2x + 26$$

$$y = -\frac{2}{8}x + \frac{26}{8}$$

$$y = -\frac{1}{4}x + \frac{13}{4}$$

The slope of the first line is $-\frac{1}{4}$.

$$x + 4y = 13$$

$$4y = -x + 13$$

$$y = -\frac{1}{4}x + \frac{13}{4}$$

The slopes are the same, so one's first thought would be to say the lines are parallel. However, since the lines have the same y-intercept, then they are in fact the same line.

33. The slope of the given line is 3, so the slope of any line perpendicular to it must have a slope of $-\frac{1}{3}$. The line passes through $(-5, 1)$, so we can determine the equation.

$$y - y_1 = m(x - x_1)$$

$$y - 1 = -\frac{1}{3}(x + 5)$$

$$y - 1 = -\frac{1}{3}x - \frac{5}{3}$$

$$y = -\frac{1}{3}x - \frac{5}{3} + \frac{3}{3}$$

$$y = -\frac{1}{3}x - \frac{2}{3}$$

34. The slope of the given line is 1. Any line parallel to this line will have the same slope. The line passes through $(-4, -4)$, so

$$y - y_1 = m(x - x_1)$$

$$y + 4 = 1(x + 4)$$

$$y + 4 = x + 4$$

$$y = x$$

35. We need to find the slope of the given line, $9x + 5y = 25$.

$$9x + 5y = 25$$

$$5y = -9x + 25$$

$$y = -\frac{9}{5}x + 5$$

The slope of the given line is $-\frac{9}{5}$, so the slope of any line perpendicular to it must have a slope of $\frac{5}{9}$. The line passes through $(-4, 4)$, so we can determine the equation.

$$y - y_1 = m(x - x_1)$$

$$y - 4 = \frac{5}{9}(x + 4)$$

$$y - 4 = \frac{5}{9}x + \frac{20}{9}$$

$$y = \frac{5}{9}x + \frac{20}{9} + \frac{36}{9}$$

$$y = \frac{5}{9}x + \frac{56}{9}$$

36. The line $y = 5$ has zero slope. Therefore, a line parallel to the given line also has zero slope. The equation of the line parallel to the given line and that passes through $(-7, 16)$ is $y = 16$.

37. The line $x = 0$ has an undefined slope. Parallel lines to this one also have undefined slope. The equation of the line parallel to the given line that passes through $(4, 6)$ is $x = 4$.

38. The line $y = -2$ has zero slope. Therefore, the line perpendicular to the line must have an undefined slope. Only vertical lines have undefined slope. Therefore, the line perpendicular to the given line and passes through $(10, 10)$ is $x = 10$.

39.

(a) Two points on the line are $(65, 6)$ and $(100, 8.25)$. The slope is

$$m = \frac{8.25 - 6}{100 - 65} = \frac{2.25}{35} \approx 0.064.$$

Then the equation is $y - 6 = 0.064(x - 65)$.

$$y - 6 = 0.064x - 4.16$$

$$y = 0.064x + 2.16$$

(b) The price to acquire the IP address is the y-intercept, which is \$2.16.

(c) The price per minute is the slope, so about 0.064, or 6.4¢ per minute.

40. (a) The slope is $\frac{1}{2}$, and the y-intercept is 5.

The equation is $y = \frac{1}{2}x + 5$.

(b) When $y = 18$, $y = \frac{1}{2}x + 5$ becomes $18 = \frac{1}{2}x + 5$

$$13 = \frac{1}{2}x$$

$$x = 13(2) = 26$$

It will take the plant 26 weeks to reach 18 inches.

41. Let x = the amount he paid for the television, and y = the amount he paid for the snake.

(a) $1.06x + 1.045y = 679.25$

(b) $1.06x + 1.045y = 679.25$

$$1.045y = -1.06x + 679.25$$

$$y = -1.014x + 650$$

[Note: change y-axis increments to 100s (100, 200, 300, etc.) and change x-axis increments to 10s (10, 20, 30, etc.)]

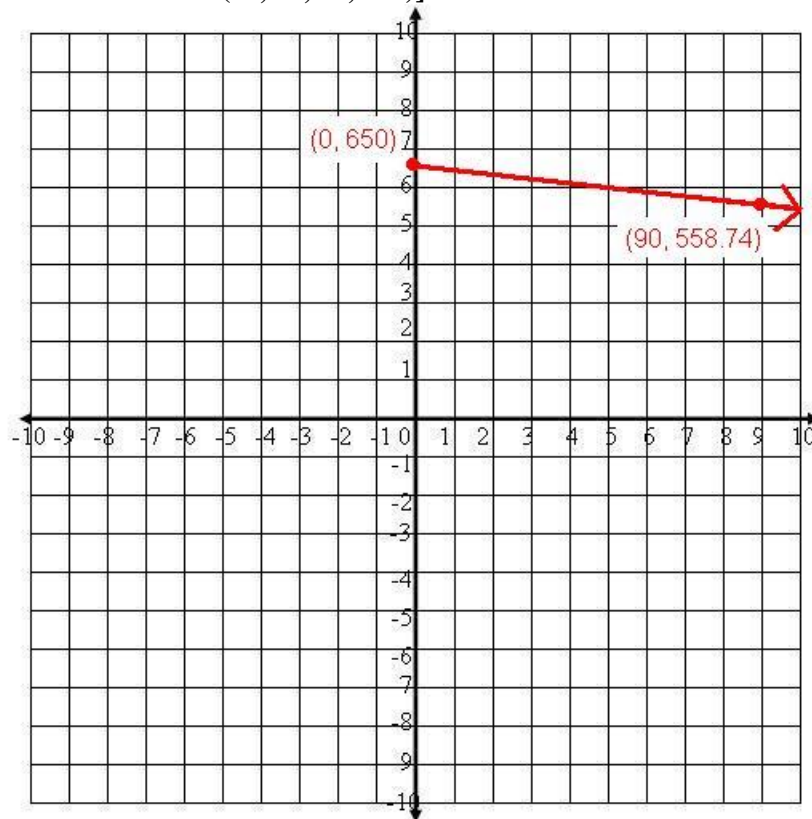

(c) Three possible solutions are $(0, 650)$: $y = -1.014(0) + 650 = 650$,

$(90, 558.74)$: $y = -1.014(90) + 650 = 558.74$, and

$(200, 447.2)$: $y = -1.014(200) + 650 = 447.2$

42. (a) The slope is $-\frac{1}{4}$, and the y-intercept is 5. The equation is $y = -\frac{1}{4}x + 5$.

(b) We need to know when $y = 0$.

$$0 = -\frac{1}{4}x + 5$$

$$-5 = -\frac{1}{4}x$$

$$x = (-5)(-4) = 20$$

It will take 20 days to empty the bucket.

43. (a) and (b) The line of best fit is drawn on the graph.

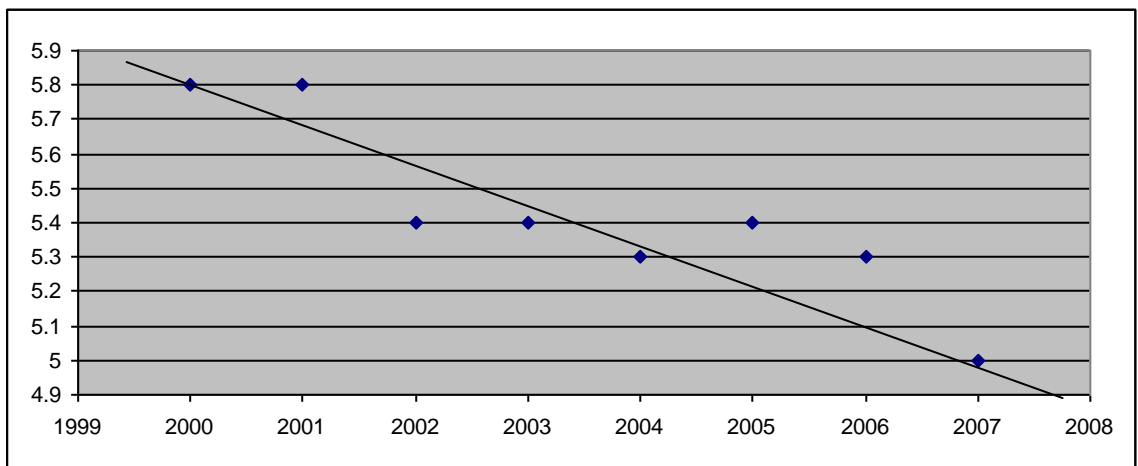

(c) The line passes through (2000, 5.8) and (2007, 5).

$$m = \frac{5 - 5.8}{2007 - 2000} = \frac{-0.8}{7} \approx -0.114$$

Then the equation is $y - 5 = -0.114(x - 2007)$

$$y - 5 = -0.114x + 228.798$$

$$y = -0.114x + 233.798$$

$$(d) y = -0.114(2011) + 233.798 = y = -229.254 + 233.798 = 4.544$$

(e)

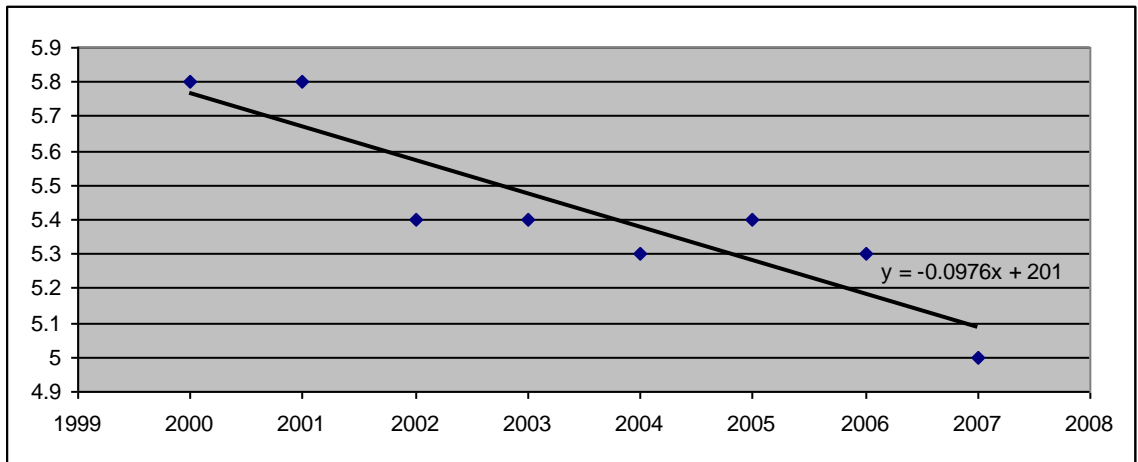

From the computer-generated equation, the slope was close, but the y-intercept was not very close.

44. (a) and (b)

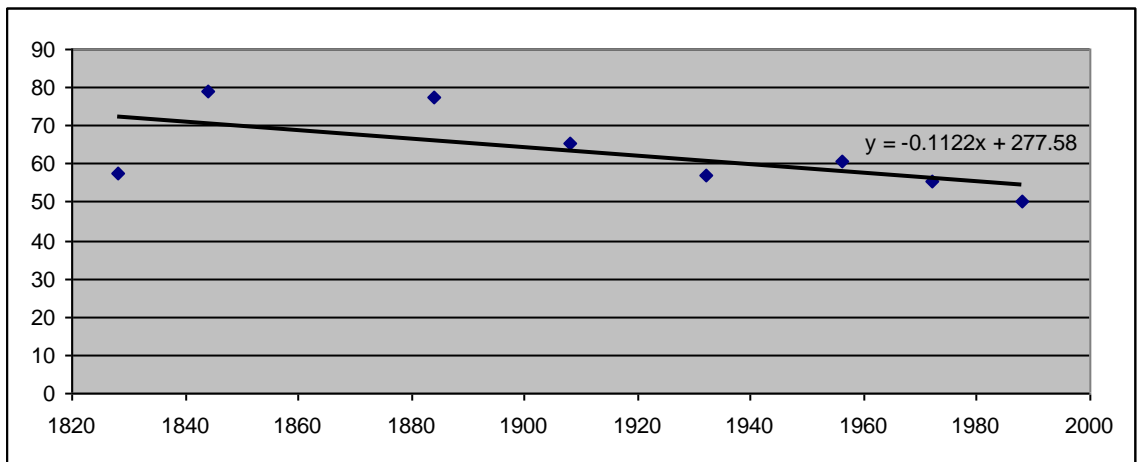

(c) $y = -0.1122(2008) + 277.58 = 52.28$

(d) The outliers are for the years 1844 and 1884. One reason could be that the elections right before and right after the Civil War has big implications.

45. (a) (4, 1600) and (5, 3200)

$$m = \frac{3200 - 1600}{5 - 4} = 1600$$

Then the equation is $y - 1600 = 1600(x - 4)$

$$y - 1600 = 1600x - 6400$$

$$y = 1600x - 4800$$

$$y = 1600(4.25) - 4800 = 2000$$

There should be about 2000 bacteria in 4.25 hours.

(b) The amount of bacteria doubles every hour. So, the next four hours will generate 12,800, 25,600, 51,200 and 102,400 bacteria.

(c) This data could not be represented by a line because the data does not increase at a linear rate.

$$46. 3 \text{ months} \left(\frac{30 \text{ days}}{1 \text{ month}} \right) \left(\frac{24 \text{ hours}}{1 \text{ day}} \right) \left(\frac{3600 \text{ seconds}}{1 \text{ hour}} \right) = 7,776,000 \text{ seconds}$$

$$47. \left(\frac{1 \text{ inch}}{2.54 \text{ centimeters}} \right) \left(\frac{1000 \text{ centimeters}}{1 \text{ kilometer}} \right) = 393.7 \text{ inches/kilometer}$$

$$48. \left(\frac{57.75 \text{ cubic inches}}{1 \text{ quart}} \right) \left(\frac{4 \text{ quarts}}{1 \text{ gallon}} \right) = 231 \text{ cubic inches/gallon}$$

49. **[Note: It is not really possible to convert from meters to acres, but it is possible to convert from square meters to acres. That is what I have done.]**

$$\left(\frac{4046.86 \text{ square meters}}{1 \text{ acre}} \right) 100 \text{ acres} = 404,686 \text{ square meters}$$

$$50. \left(\frac{6 \text{ feet}}{1 \text{ fathom}} \right) 616 \text{ fathoms} = 3,696 \text{ feet}$$

Lesson 5.10 Chapter 5 Test

1. $y = \frac{-3}{2}x + 4$

$$-2y = 3x + 4$$

$$3x + 2y = -4$$

2. The slope of the given line is $\frac{1}{3}$. So the slope of any line perpendicular to it will have a slope of -3 . The line passes through $(1, 2)$, so

$$y - 2 = -3x - 1$$

$$y = -3x + 1$$

3. $m = \frac{0.5 - 3}{-6 - 5} = \frac{-2.5}{-11} \approx 0.227$

Then the equation is $y - 3 = 0.227(x - 5)$

$$y - 3 = 0.227x - 1.135$$

4. $\left(\frac{80 \text{ miles}}{1 \text{ hour}}\right)\left(\frac{5280 \text{ feet}}{1 \text{ mile}}\right)\left(\frac{1 \text{ hour}}{3600 \text{ seconds}}\right) = 117.33 \text{ feet/second}$

5. $\left(\frac{1.61 \text{ kilometers}}{1 \text{ mile}}\right) 26.2 \text{ miles} = 42.182 \text{ kilometers}$

6. (a)

Let r = the number of rooms. Then $5 - \frac{2}{3}r$.

(b) $5 - \frac{2}{3}(7) = 4\frac{2}{3}$, so Lucas can paint 7 rooms before he runs out. He can start on an 8th, but cannot finish.

7. The first line, $y = 3x - 1$ has a slope of 3 and a y-intercept of -1 . The second line needs to be converted to slope-intercept form.

$$-x + 3y = 6$$

$$3y = x + 6$$

$$y = \frac{1}{3}x + 2$$

The lines are neither parallel nor perpendicular.

8. (a)

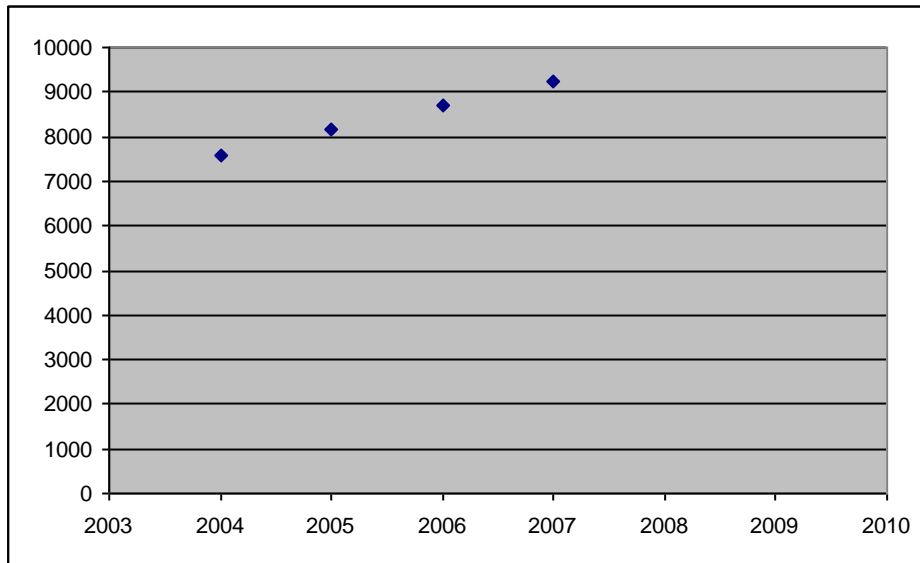

(b) The average increase per year is about 550. So, in two years, the gross public debt will be about $9200 + 2(550) = 10,300$.

(c) The equation is $y = 540.91x - 1,000,000$.

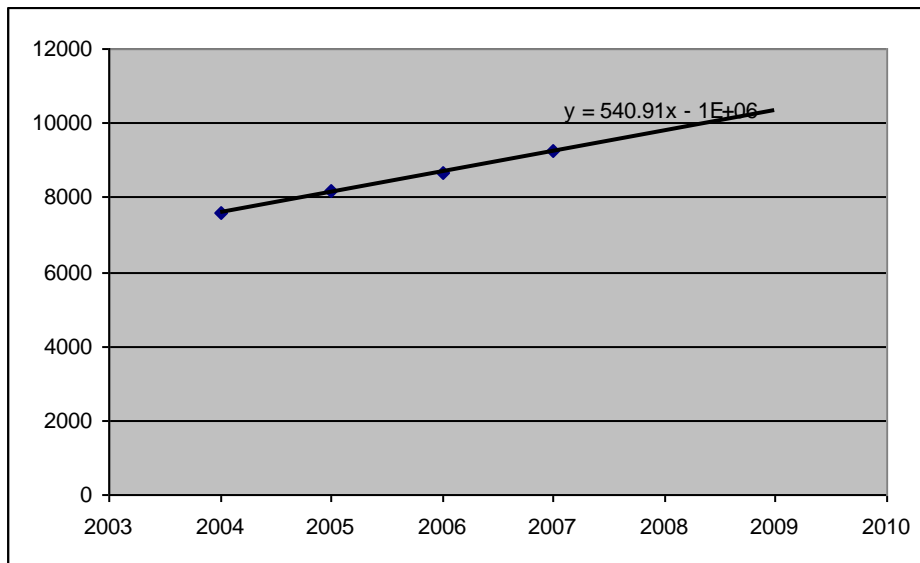

(d) $y = 540.91(2009) - 1,000,000 = 86,688.19$

(e) The extrapolation is much more accurate.

9. To interpolate a point, draw a line between the nearest data point to the left and the right of the desired data point. Then calculate the equation of the line by identifying the slope and using one of the given points.

10. (a)

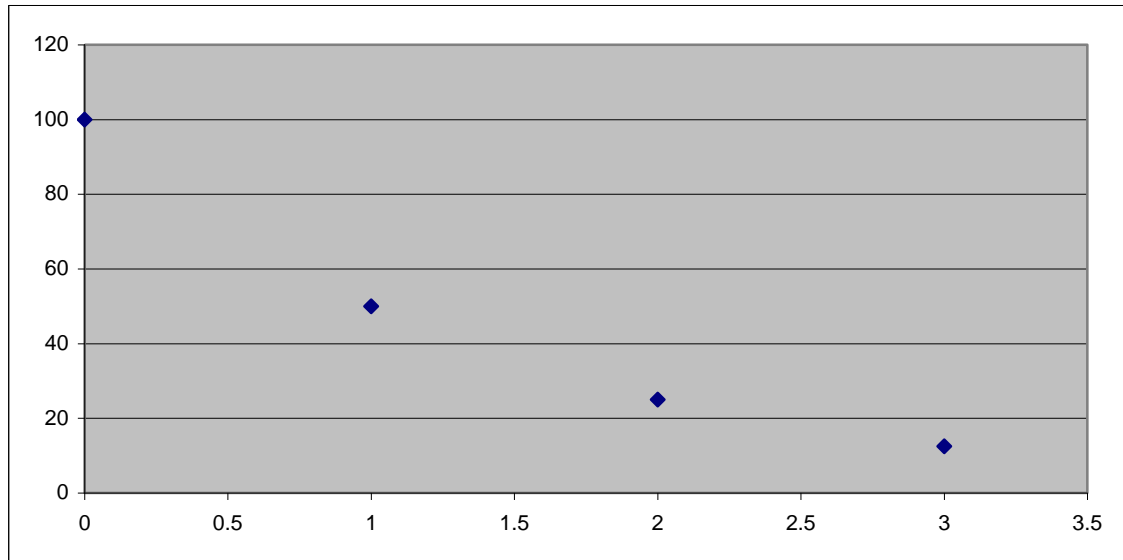

(b) A linear regression line would not be the best way to represent the data because the points are not linear.

$$(c) m = \frac{25 - 50}{2 - 1} = \frac{-25}{1} = -25$$

Let p = percent remaining

$$p - 50 = -25(h - 1)$$

$$p - 50 = -25h + 25$$

$$p = -25h + 75$$

$$p = -25(2.75) + 75 = -68.75 + 75 = 6.25$$

Chapter 6
Lesson 6.1

1. Inequality notation: The answer is expressed as an algebraic inequality.
 2. Set notation: The inequality is rewritten using set notation brackets $\{ \}$.
 3. Interval notation: This notation uses brackets to denote the range of values in an inequality.
 4. As a graphed sentence on a number line.
- 2.

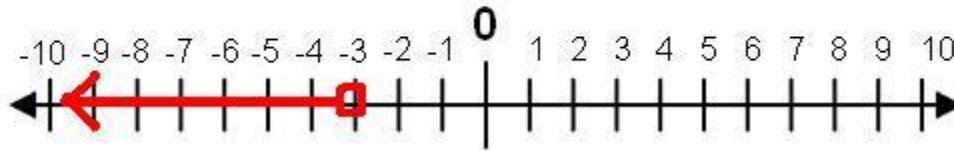

3.

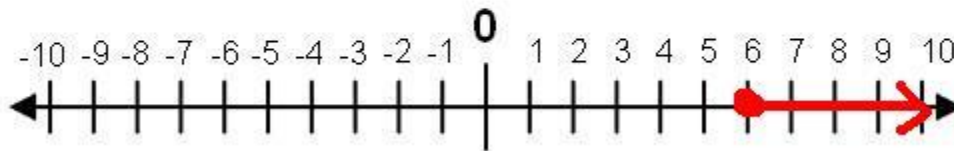

4.

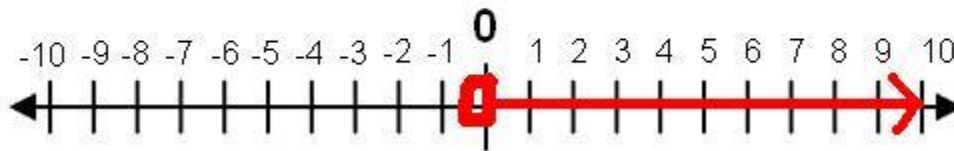

5.

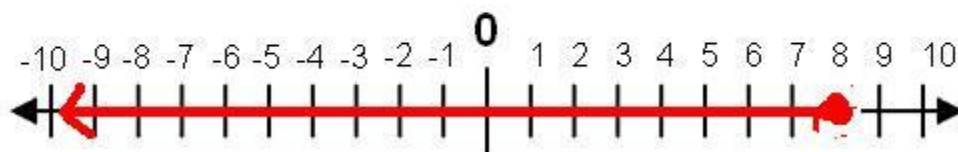

6.

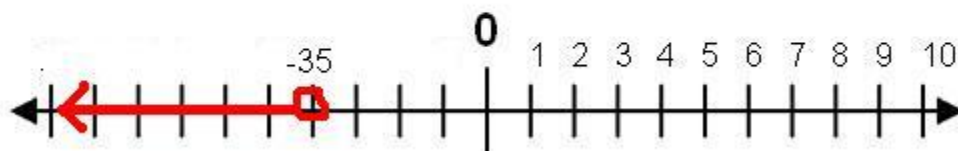

7.

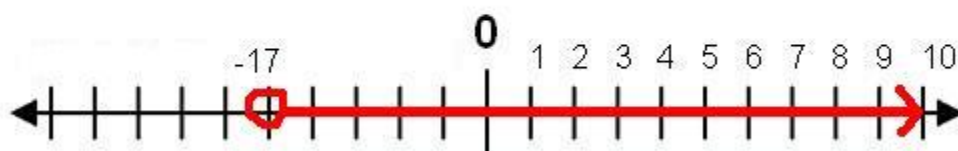

8.

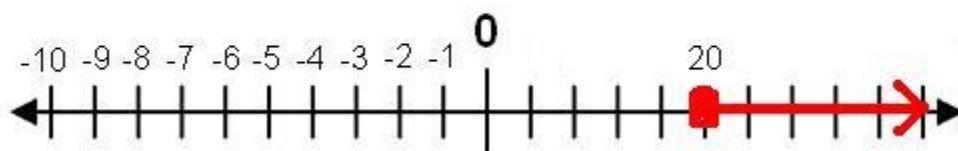

9.

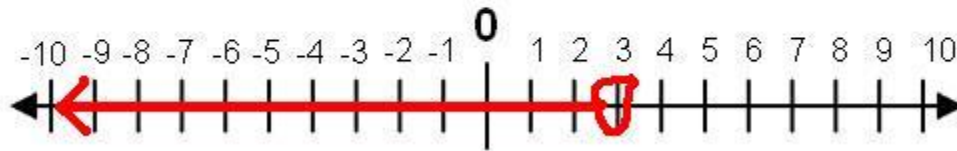

10. $x \leq -12$

11. $x > 520$

12. $x < 6.5$

13. $x \geq 85$

14. $x > 30$

15. $x < -10$

16. $x \leq -10$

17. $x \geq 1$

18. $x \geq 48$

19. $x < 3$

20. $x > 1,800$

21. $x \leq 6$

22. $x \leq 16$

$$\begin{aligned} 23. \quad x - 1 &> -10 \\ +1 \quad +1 \\ x &> -9 \end{aligned}$$

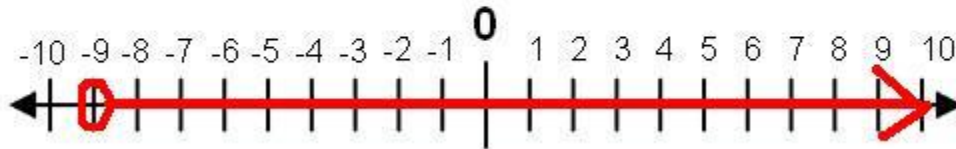

$$\begin{aligned} 24. \quad x - 1 &\leq -5 \\ +1 \quad +1 \\ x &\leq -4 \end{aligned}$$

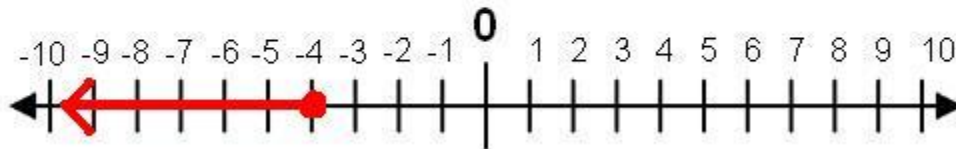

$$\begin{aligned} 25. \quad -20 + a &\geq 14 \\ +20 \quad +20 \\ a &\geq 34 \end{aligned}$$

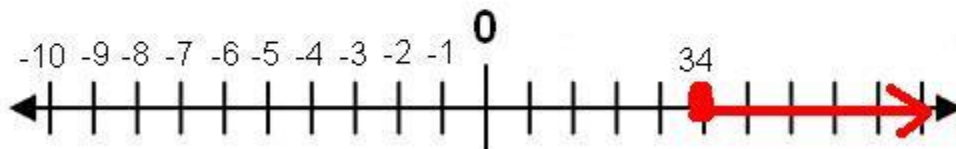

$$\begin{aligned} 26. \quad x + 2 &< 7 \\ -2 \quad -2 \\ x &< 5 \end{aligned}$$

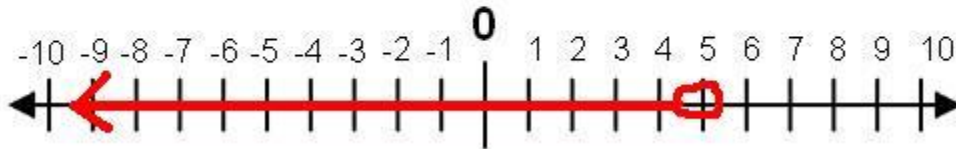

$$\begin{aligned} 27. \quad x + 8 &\leq -7 \\ -8 \quad -8 \\ x &\leq -15 \end{aligned}$$

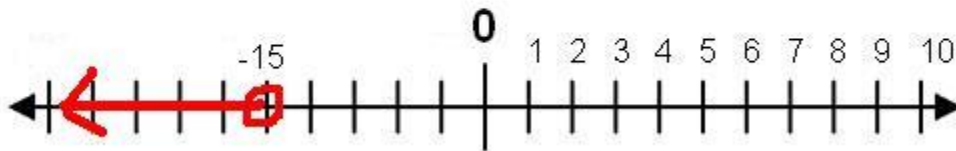

$$\begin{aligned} 28. \quad 5 + t &> \frac{3}{4} \\ t &> \frac{3}{4} - 5 \\ t &> \frac{3}{4} - \frac{20}{4} \\ t &> -\frac{17}{4} \end{aligned}$$

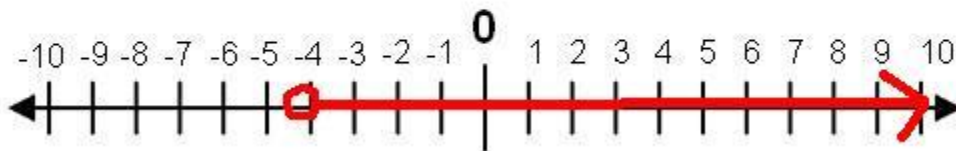

$$\begin{aligned} 29. \quad x - 5 &< 35 \\ +5 \quad +5 \\ x &< 40 \end{aligned}$$

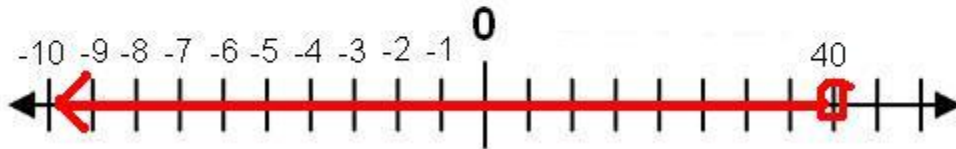

$$\begin{aligned} 30. \quad 15 + g &\geq -60 \\ -15 \quad -15 \\ g &\geq -75 \end{aligned}$$

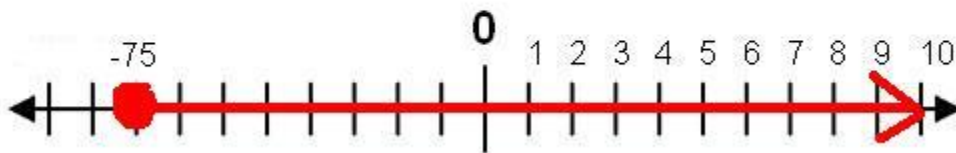

$$\begin{aligned} 31. \quad x - 2 &\leq 1 \\ +2 \quad +2 \\ x &\leq 3 \end{aligned}$$

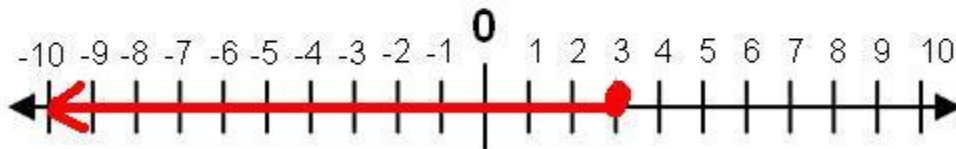

$$\begin{array}{r} 32. \quad x - 8 > 20 \\ \quad +8 \quad +8 \\ \hline \quad x > 28 \end{array}$$

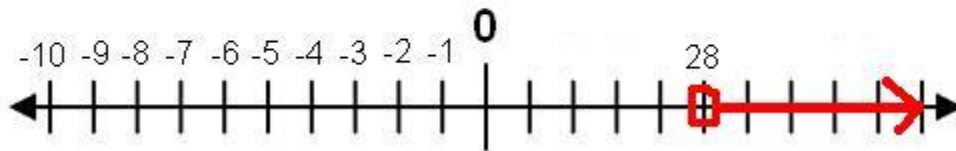

$$\begin{array}{r} 33. \quad 11 + q < 13 \\ \quad -11 \quad -11 \\ \hline \quad q < 2 \end{array}$$

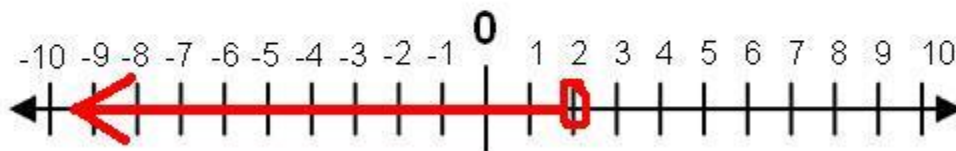

$$\begin{array}{r} 34. \quad x + 65 < 100 \\ \quad -65 \quad -65 \\ \hline \quad x < 35 \end{array}$$

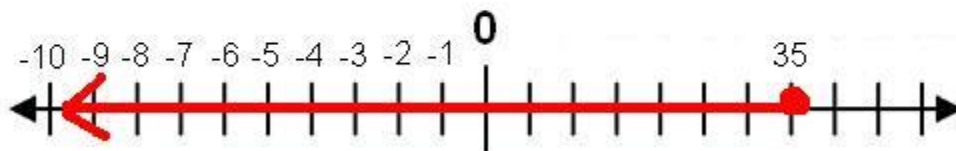

$$\begin{aligned} 35. \quad x - 32 &\leq 0 \\ +32 \quad +32 \\ x &\leq 32 \end{aligned}$$

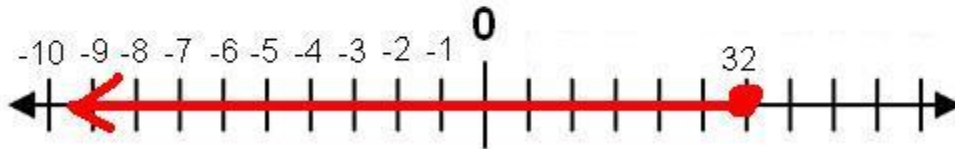

$$\begin{aligned} 36. \quad x + 68 &\geq 75 \\ -68 \quad -68 \\ x &\geq 7 \end{aligned}$$

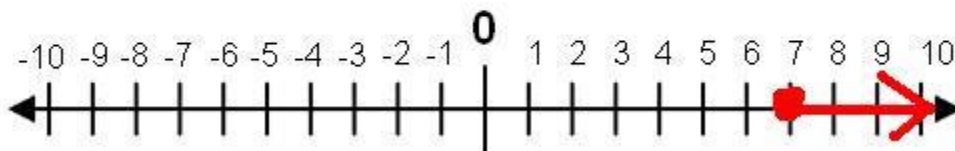

$$\begin{aligned} 37. \quad 16 + y &\leq 0 \\ -16 \quad -16 \\ y &\leq -16 \end{aligned}$$

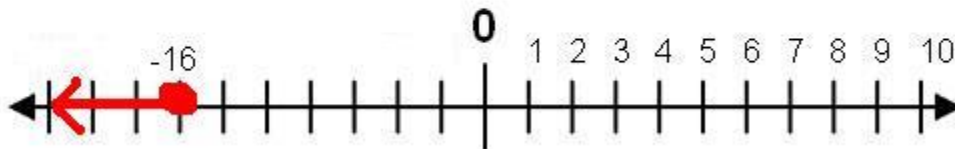

38. Two points on the line are $(3, -6)$ and $(-2, -2)$.

$$\text{The slope of the line is } m = \frac{-2 - (-6)}{-2 - 3} = \frac{8}{-5} = -\frac{8}{5}$$

$$y - y_1 = m(x - x_1)$$

$$y + 6 = -\frac{8}{5}(x - 3)$$

$$y + 6 = -\frac{8}{5}x + \frac{24}{5}$$

$$y = -\frac{8}{5}x - \frac{6}{5}$$

39. $|2 - 11 \times 3| + 1$

$$|-27| + 1$$

$$27 + 1$$

$$28$$

40. w

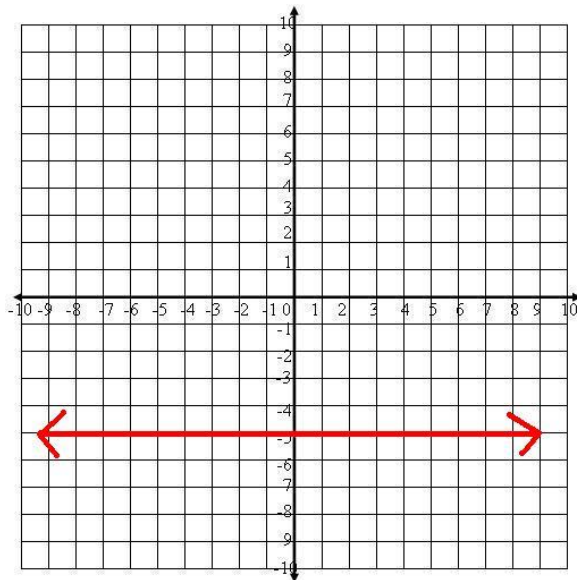

41. $y = kx$, where k is the constant of variability

$$\frac{y}{x} = \frac{y}{x}$$

$$\frac{4}{-1} = \frac{y}{\frac{16}{3}}$$

$$-y = \left(\frac{4}{5}\right)\left(\frac{16}{3}\right)$$

$$-y = \frac{64}{15}$$

$$y = -\frac{64}{15}$$

42. $-2x + 7y = 63$

$$7y = 2x + 63$$

$$y = \frac{2}{7}x + 9$$

Lesson 6.2

1. One would change the inequality sign when dividing or multiplying by a negative number.
2. $3x < 6$
 $x < 2$

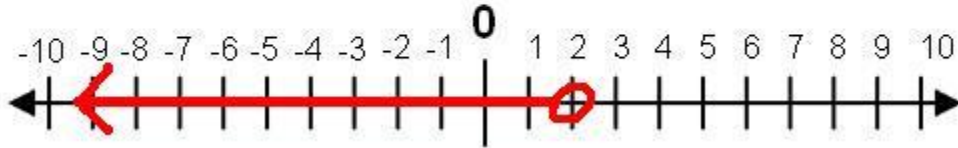

3. $\frac{x}{5} > -\frac{3}{10}$
 $x > \frac{-15}{10}$
 $x > -\frac{3}{2}$

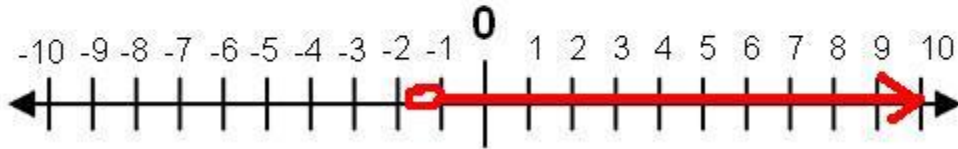

4. $-10x > 250$
 $x < -25$

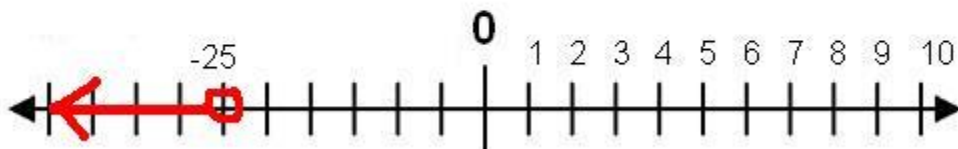

5. $\frac{x}{-7} \geq -5$
 $x \geq 35$

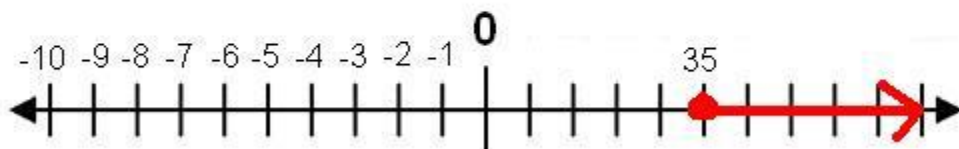

6. $9x > -\frac{3}{4}$
 $x > -\frac{3}{4}(9)$
 $x > -\frac{27}{4}$

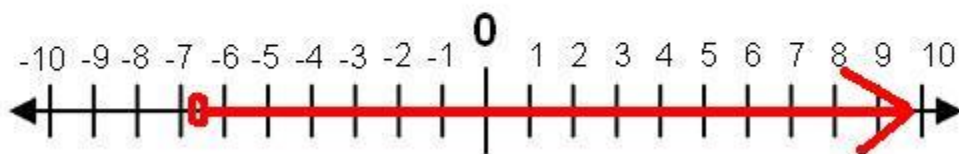

7. $\frac{x}{-15} \leq 5$
 $x \geq -75$

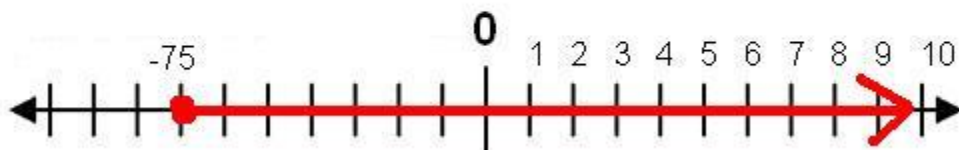

8. $620x > 2400$

$$x > \frac{115}{31}$$

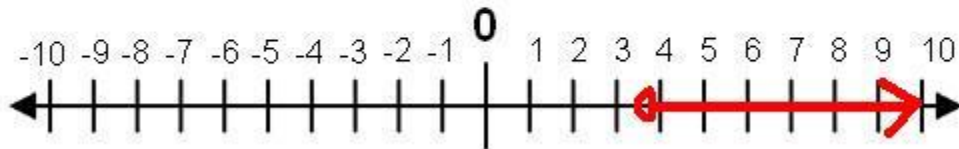

9. $\frac{x}{20} \leq \frac{-7}{40}$
 $x \leq -\frac{7}{2}$

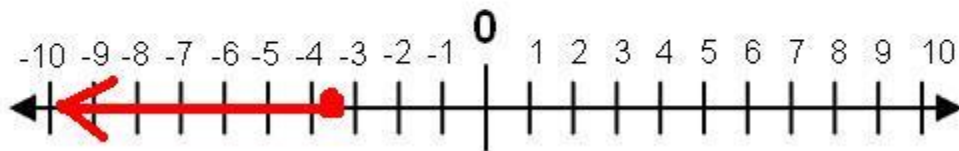

10. $-0.5x \leq 7.5$
 $x \geq -15$

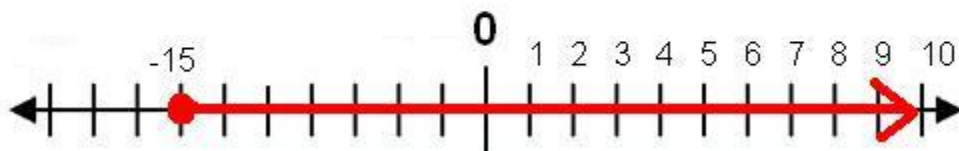

$$11. 75x \geq 125$$

$$x \geq \frac{5}{3}$$

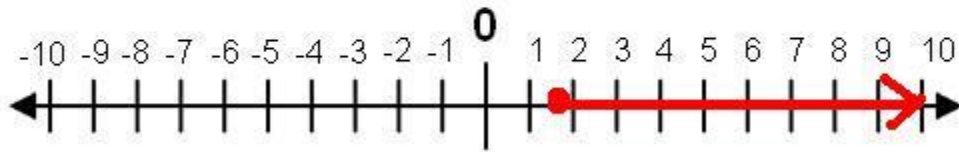

$$12. \frac{x}{-3} > -\frac{10}{9}$$

$$x < \frac{30}{9}$$

$$x < \frac{10}{3}$$

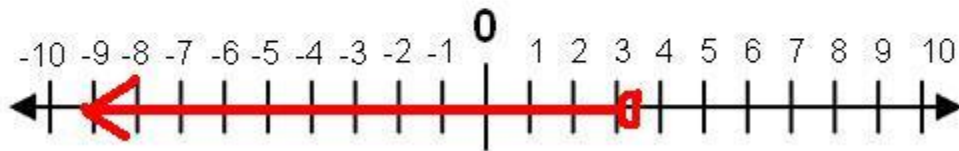

$$13. \frac{k}{-14} \leq 1$$

$$k \geq -14$$

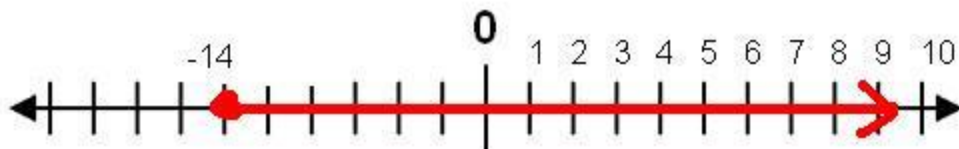

$$14. \frac{x}{-15} < 8$$
$$x > -120$$

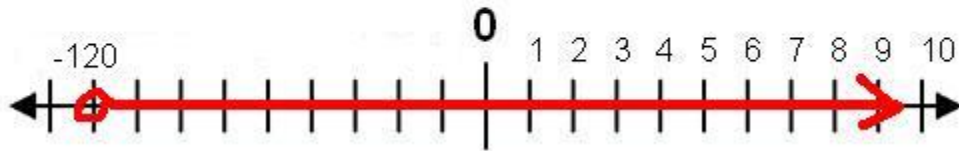

$$15. \frac{x}{2} > 40$$
$$x > 80$$

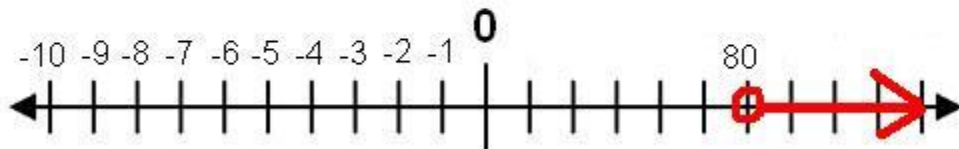

$$16. \frac{x}{-3} \leq -12$$
$$x > 36$$

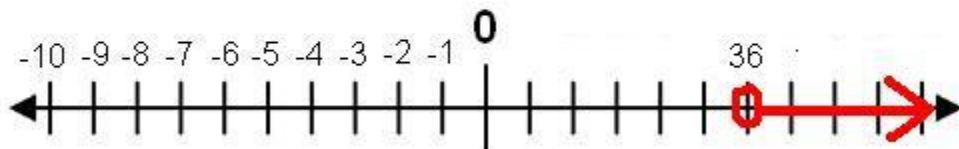

$$17. \frac{x}{25} < \frac{3}{2}$$

$$x < \frac{3}{2}(25)$$

$$x < \frac{75}{2}$$

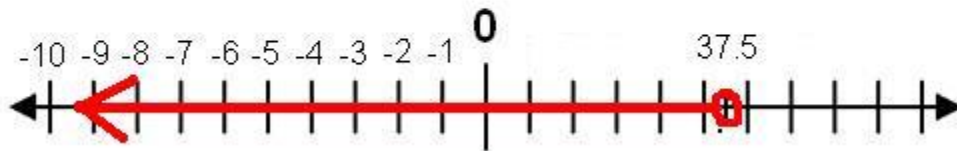

$$18. \frac{x}{-7} \geq 9$$

$$x < -63$$

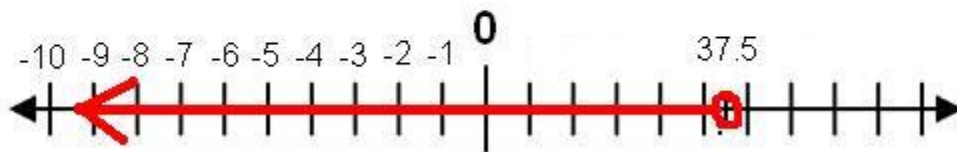

$$19. 4x < 24$$

$$x < 6$$

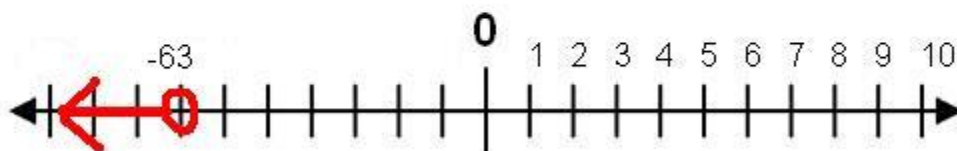

20. $238 < 14d$
 $17 < d$

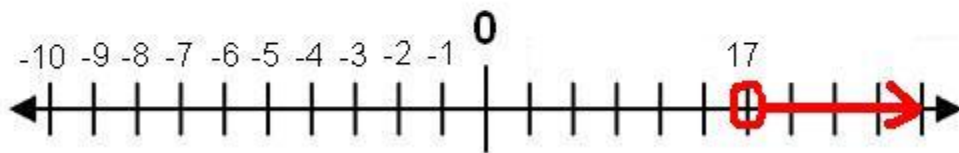

21. $-19m < -285$
 $m \geq 15$

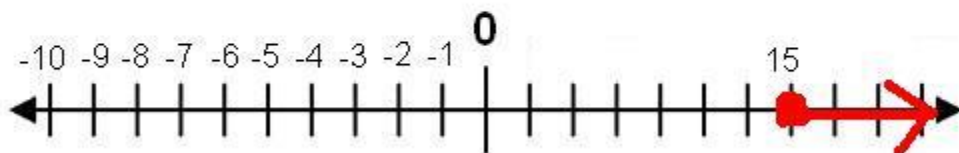

22. $-9x \leq -\frac{3}{5}$
 $x \geq -\frac{3}{5} \left(-\frac{1}{9}\right)$
 $x \geq \frac{1}{15}$

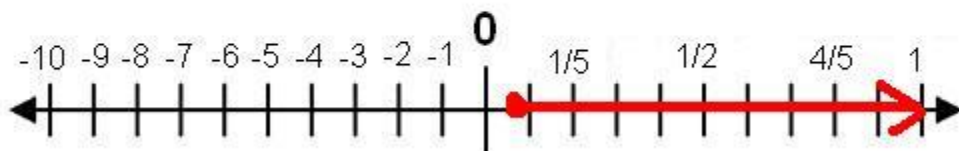

$$23. -5x \leq 21$$

$$x \geq -\frac{21}{5}$$

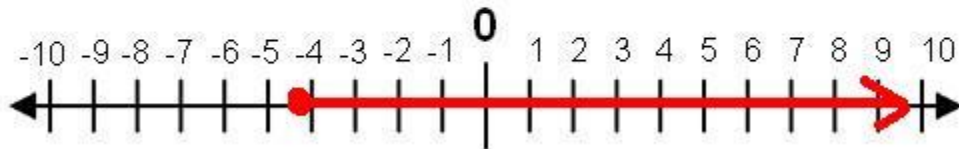

$$24. lw = A$$

$$16l > 180$$

$$l > 11.25$$

$$25. 0.90x \leq 45$$

$$x < 50$$

$$26. 2x \geq 22$$

$$x \geq 11$$

$$[11, \infty)$$

$$27. c = \text{the number of cookies Anna had to make}$$

$$c - 36 \leq 24$$

$$c \leq 60$$

$$\{c \mid c \leq 60\}$$

$$28. 31.85 + d \geq 97.12, \text{ where } d = \text{the deposit}$$

$$d \geq 65.27$$

$$29. v = -|2 - (-19) + 6| = -|21 + 6| = -(27) = -27$$

30. a. Let d = the number of dimes and q = the number of quarters. Then

$$0.10d + 0.25q = 26.00$$

$$0.25q = -0.10d + 26.00$$

$$q = -\frac{2}{5}d + 104$$

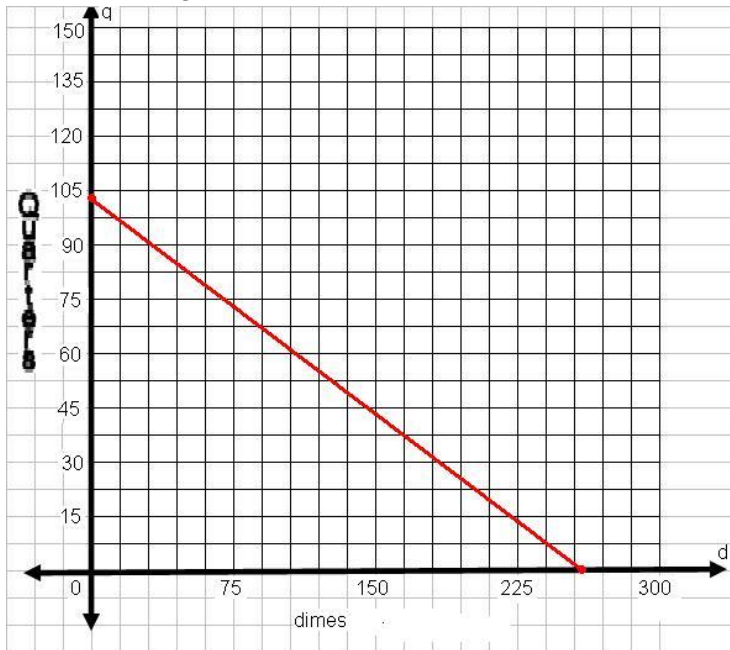

b. $26.00 - 13.50 = 12.50$

$$\frac{12.50}{0.1} = 125$$

There would be 125 dimes.

Lesson 6.3

1. $6x - 5 < 10$
 $6x < 15$
 $x < \frac{5}{3}$ OR $1.\bar{6}$

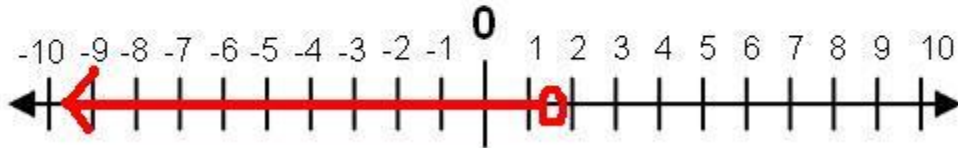

2. $-9x < -5x - 15$
 $+5x \quad +5x$
 $-4x < -15$
 $x > \frac{15}{4}$ OR 3.75

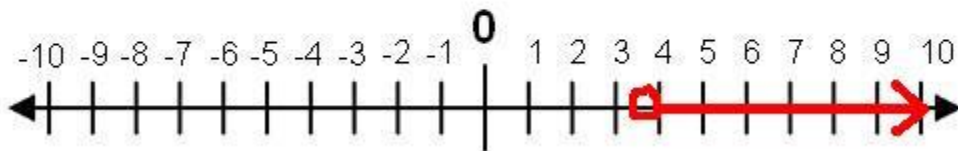

3. $\frac{-9x}{5} \leq 24$
 $x \geq 24 \left(-\frac{5}{9} \right)$
 $x \geq -\frac{40}{3}$ OR $13.\bar{3}$

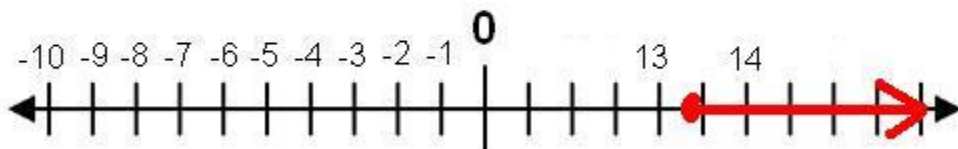

$$\begin{aligned}
 4. \quad & \frac{9x}{5} - 7 \geq -3x + 12 \\
 & + 7 \qquad \qquad + 7 \\
 & 5\left(\frac{9x}{5}\right) \geq 5(-3x + 19) \\
 & 9x \geq -15x + 19 \\
 & 24x \geq 95 \\
 & x \geq \frac{95}{24} \text{ OR } 3\frac{23}{24}
 \end{aligned}$$

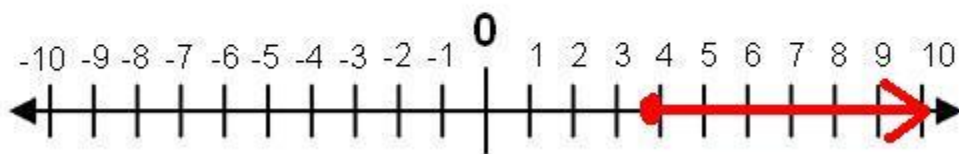

$$\begin{aligned}
 5. \quad & \frac{5x-1}{4} > -2x-10 \\
 & 5x-1 > 4(-2x-10) \\
 & 5x-1 > -8x-40 \\
 & 13x-1 > -40 \\
 & 13x > -39 \\
 & x > -3
 \end{aligned}$$

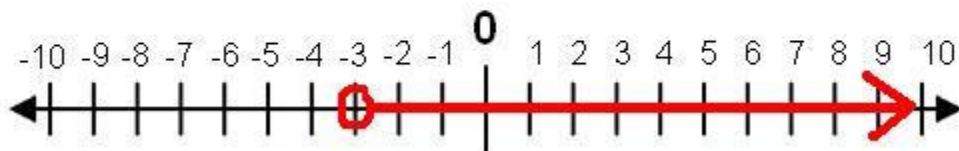

6. $4x + 3 < -1$
 $4x < -4$
 $x < -1$

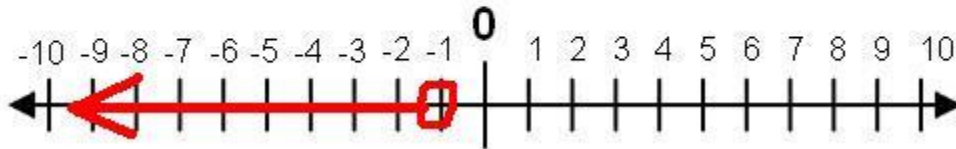

7. $2x < 7x - 36$
 $-5x < -36$
 $x > \frac{36}{5}$ OR $7\frac{1}{5}$

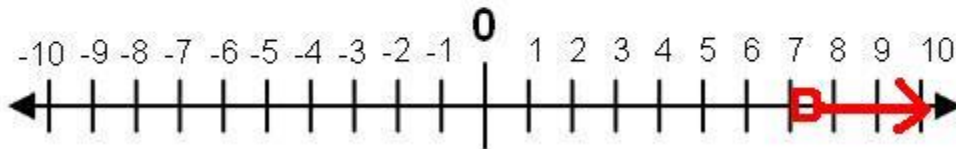

8. $5x > 8x + 27$
 $-3x > 27$
 $x < -9$

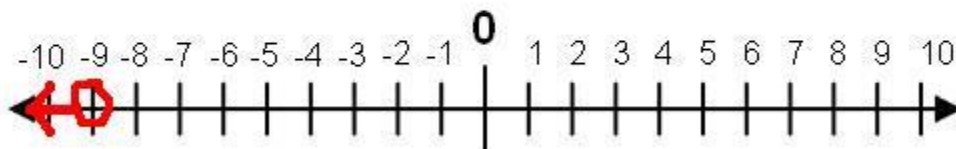

$$\begin{aligned} 9. \quad & 5 - x < 9 + x \\ & 5 < 9 + 2x \\ & -4 < 2x \\ & -2 < x \\ & \text{OR} \\ & x > -2 \end{aligned}$$

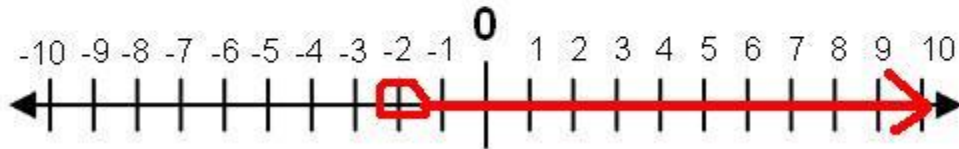

$$\begin{aligned} 10. \quad & 4 - 6x \leq 4x + 6 \\ & 4 \leq 10x + 6 \\ & -2 \leq 10x \\ & -\frac{1}{5} \leq x \\ & \text{OR} \\ & x \geq -\frac{1}{5} \end{aligned}$$

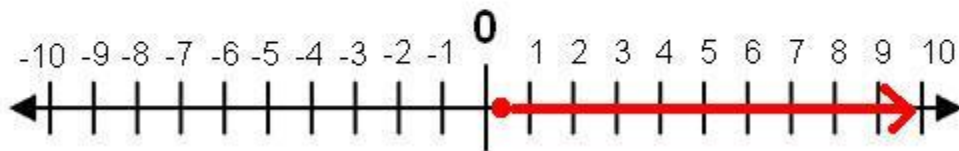

$$\begin{aligned}
 11. \quad & 5(4x + 3) \geq 9(x - 2) - x \\
 & 20x + 15 \geq 9x - 18 - x \\
 & 20x + 15 \geq 8x - 18 \\
 & 12x + 15 \geq -18 \\
 & 12x \geq -33 \\
 & x \geq -\frac{33}{12} \text{ OR } -2\frac{3}{4}
 \end{aligned}$$

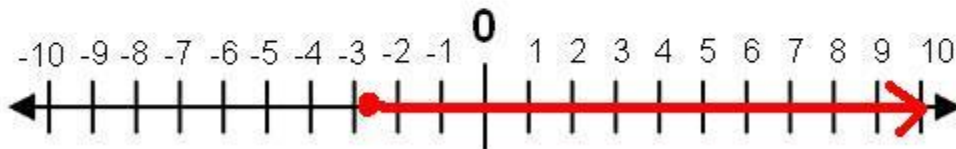

$$\begin{aligned}
 12. \quad & 2(2x - 1) + 3 < 5(x + 3) - 2x \\
 & 4x - 2 + 3 < 5x + 15 - 2x \\
 & 4x + 1 < 3x + 15 \\
 & x + 1 < 15 \\
 & x < 14
 \end{aligned}$$

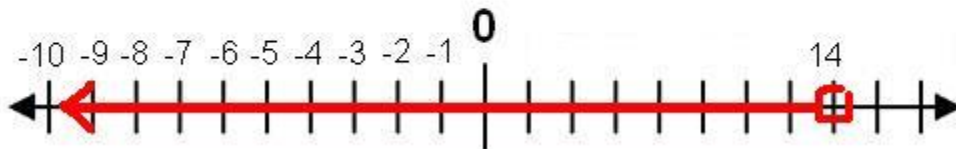

$$13. 8x - 5(4x + 1) \geq -1 + 2(4x - 3)$$

$$8x - 20x - 5 \geq -1 + 8x - 6$$

$$-12x - 5 \geq 8x - 7$$

$$-20x - 5 \geq -7$$

$$-20x \geq -2$$

$$x \leq \frac{1}{10}$$

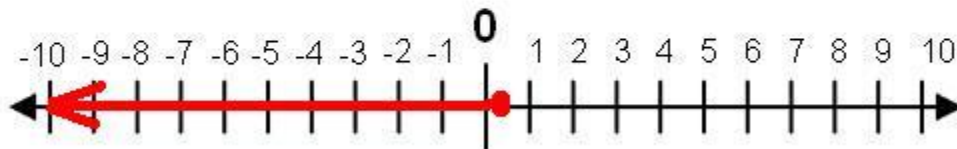

$$14. 2(7x - 2) - 3(x + 2) < 4x - (3x + 4)$$

$$14x - 4 - 3x - 6 < 4x - 3x - 4$$

$$11x - 10 < x - 4$$

$$10x - 10 < -4$$

$$10x < 6$$

$$x < \frac{3}{5}$$

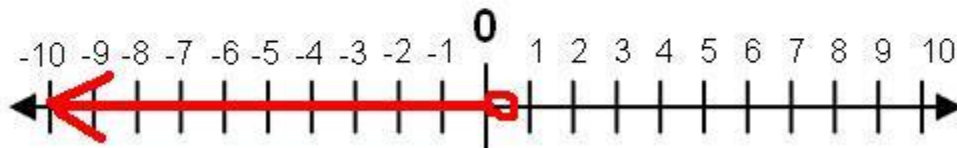

$$15. \frac{2}{3}x - \frac{1}{2}(4x-1) \geq x + 2(x-3)$$

$$\frac{2}{3}x - 2x + \frac{1}{2} \geq x + 2x - 6$$

$$-\frac{4}{3}x + \frac{1}{2} \geq 3x - 6$$

$$-\frac{16}{3}x + \frac{1}{2} \geq -6$$

$$-\frac{16}{3}x \geq -\frac{13}{2}$$

$$x \leq \left(-\frac{13}{2}\right)\left(-\frac{3}{16}\right)$$

$$x \leq \frac{39}{32} \text{ OR } 1\frac{7}{32}$$

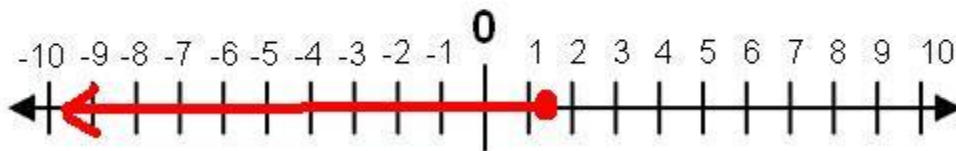

16. Let x = the number of visits to the zoo.

$$22.75x > 71$$

$$x > \frac{71}{22.75} \approx 3.1208$$

A visitor can visit at most 3 times before exceeding the yearly pass price.

17. Let x = the score needed for the last test.

$$\frac{82+95+86+88+x}{5} \geq 90$$

$$\frac{351+x}{5} \geq 90$$

$$351+x \geq 450$$

$$x \geq 99$$

He must score a 99 on the final test to have an average of at least 90.

18. Let t = the number of ties he buys.

$$50t \leq 200$$

$$t \leq 4$$

At most, he can buy 4 ties.

19. Let b = the number of boxes of cookies.

$$4.50b \geq 650$$

$$b \geq 144.4\dots$$

The troupe must sell at least 145 boxes of cookies.

20. $10 \geq -5f$

$$-2 \leq f$$

21.

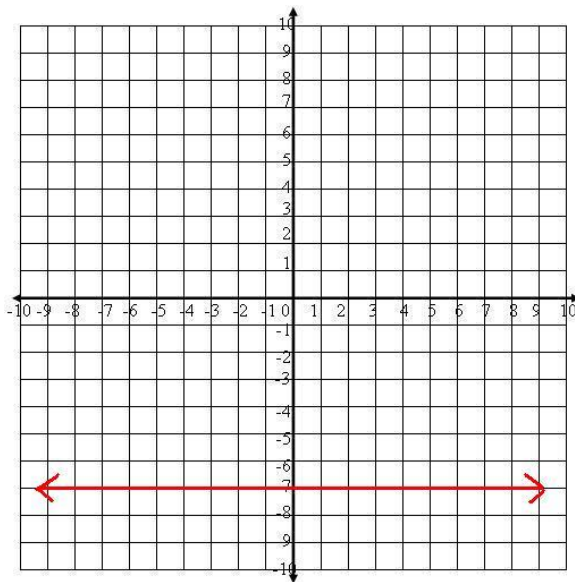

22. The value $\sqrt{5}$ is a real, irrational number.

23. a) Make a Table – Example: *Josie takes up jogging. On the first week she jogs for 10 minutes per day, on the second week she jogs for 12 minutes per day. Each week, she wants to increase her jogging time by 2 minutes per day. If she jogs six days per week each week, what will be her total jogging time on the sixth week?*

b) Look for a Pattern – Example: *You arrange tennis balls in triangular shapes as shown. How many balls will there be in a triangle that has 8 layers?*

c) Guess and Check – Example: *Nadia takes a ribbon that is 48 inches long and cuts it in two pieces. One piece is three times as long as the other. How long is each piece?*

d) Work Backward – Example: *Anne has a certain amount of money in her bank account on Friday morning. During the day she writes a check for \$24.50, makes an ATM withdrawal of \$80 and deposits a check for \$235. At the end of the day she sees that her balance is \$451.25. How much money did she have in the bank at the beginning of the day?*

- e) Use a Formula – Example: *An architect is designing a room that is going to be twice as long as it is wide. The total square footage of the room is going to be 722 square feet. What are the dimensions in feet of the room?*
- f) Read a Graph – Example: *Christine took one hour to read 22 pages of “Harry Potter and the Order of the Phoenix.” She has 100 pages left to read in order to finish the book. Assuming that she reads at a constant rate of pages per hour, how much time should she expect to spend reading in order to finish the book?*
- g) Make a Graph – Example: *A cell phone company is offering its costumers the following deal. You can buy a new cell phone for \$60 and pay a monthly flat rate of \$40 per month for unlimited calls. How much money will this deal cost you after 9 months?*
- h) Use a Linear Model – Example: *A cylinder is filled with water to a height of 73 centimeters. The water is drained through a hole in the bottom of the cylinder and measurements are taken at two second intervals. The table below shows the height of the water level in the cylinder at different times.*
- i) Dimensional Analysis – Example: *How many grams are in 5 pounds?*

$$24. \quad A = \pi r^2$$

$$196\pi = \pi r^2$$

$$196 = r^2$$

$$14 \text{ inches} = r$$

$$25. \quad \frac{6}{a} = \frac{-22}{a+4}$$

$$-22a = 6(a+4)$$

$$-22a = 6a + 24$$

$$-28a = 24$$

$$a = \frac{24}{-28} = -\frac{6}{7}$$

Lesson 6.4

1. The solution set to a compound inequality joined by the word “and” will have two endpoints and all the numbers between the points shaded.
2. The difference with “or” inequalities is the shading would be on the outside of the points instead of between them.
3.
 1. Separate the inequality into two distinct inequalities.
 2. Determine if there should be an “and” or an “or” between them.
 3. Solve each individual inequality.
 4. Graph the solutions which satisfy both inequalities.
4. $-40 \leq x < 60$
5. $x < -2$ or $x \geq 5$
6. $-8 < x < 0$
7. $x \leq -2$ or $x > 1.5$
8. $-25 < x < 25$
9. $x \leq -1$ or $x \geq 4$
10. $x < -2$ or $x > 1$

11.

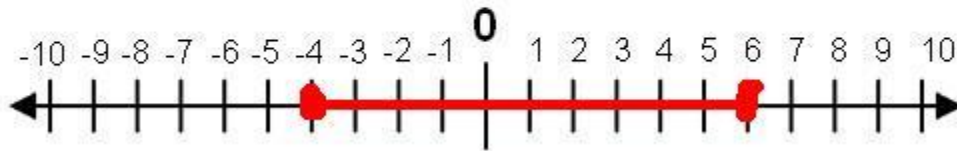

12.

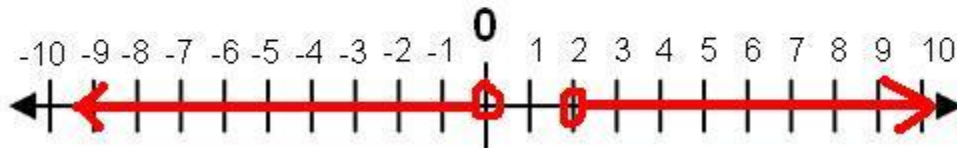

13.

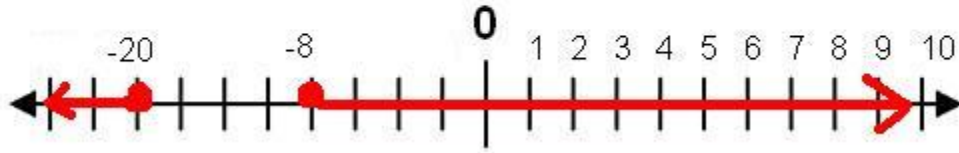

14.

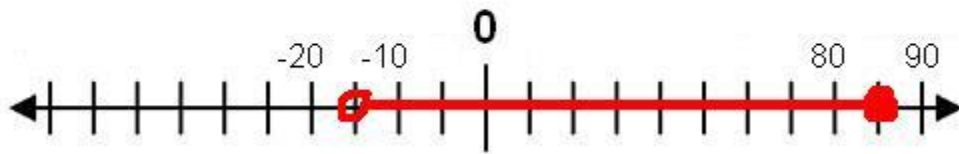

15. $-5 \leq x - 4 \leq 13$

$-5 \leq x - 4$

AND

$x - 4 \leq 13$

$-1 \leq x$

AND

$x \leq 17$

$-1 \leq x \leq 17$

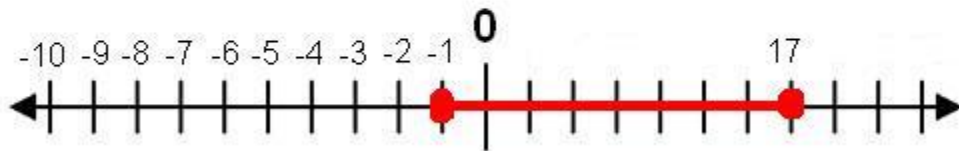

$$16. -2 < 4x - 5 \leq 11$$

$$\begin{array}{lll} -2 < 4x - 5 & \text{AND} & 4x - 5 \leq 11 \\ 3 < 4x & \text{AND} & 4x \leq 16 \\ 0.75 < x & & x < 4 \\ & & 0.75 < x \leq 4 \end{array}$$

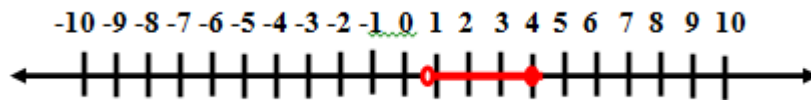

$$17. \frac{x-2}{6} \leq 2x-4 \text{ OR } \frac{x-2}{6} > x+5$$

$$\begin{array}{lll} x-2 \leq 12x-24 & \text{OR} & x-2 > 6x+30 \\ -11x \leq -22 & \text{OR} & -5x > 32 \\ x \geq 2 & \text{OR} & x < -\frac{32}{5} \end{array}$$

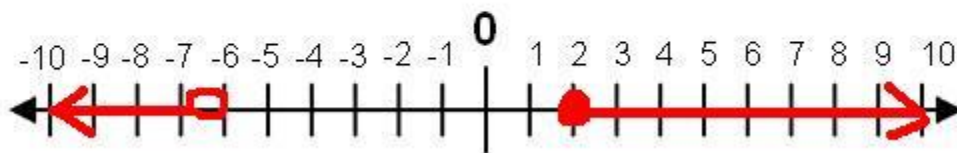

$$18. 1 \leq 3x + 4 \leq 4$$

$$1 \leq 3x + 4$$

AND

$$3x + 4 \leq 4$$

$$-3 \leq 3x$$

AND

$$3x \leq 0$$

$$-1 \leq x$$

AND

$$x \leq 0$$

$$-1 \leq x \leq 0$$

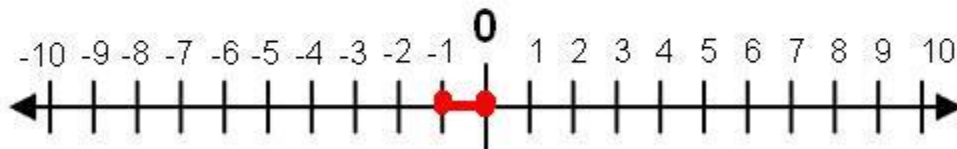

$$19. -12 < 2 - 5x \leq 7$$

$$-12 < 2 - 5x$$

AND

$$2 - 5x \leq 7$$

$$-14 < -5x$$

AND

$$-5x \leq 5$$

$$\frac{14}{5} > x$$

AND

$$x \geq -1$$

$$-1 \leq x < 2\frac{4}{5}$$

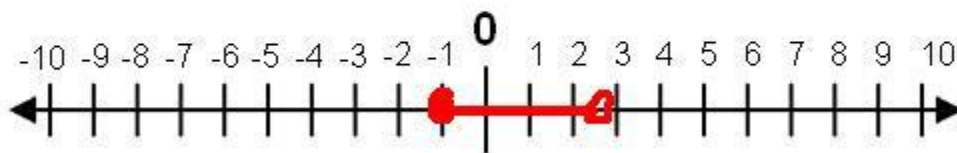

$$20. \frac{3}{4} \leq 2x+9 \leq \frac{3}{2}$$

$$\frac{3}{4} \leq 2x+9 \quad \text{AND} \quad 2x+9 \leq \frac{3}{2}$$

$$-\frac{33}{4} \leq 2x \quad \text{AND} \quad 2x \leq -\frac{15}{2}$$

$$-\frac{33}{8} \leq x \quad \text{AND} \quad -\frac{15}{4} \leq x$$

$$-4\frac{1}{8} \leq x \leq -3\frac{3}{4}$$

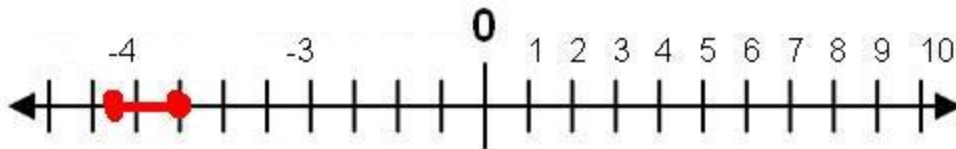

21.

$$-2 < \frac{2x-1}{3} < -1$$

$$-2 < \frac{2x-1}{3} \quad \text{AND} \quad \frac{2x-1}{3} < -1$$

$$-6 < 2x-1 \quad \text{AND} \quad 2x-1 < -3$$

$$-5 < 2x \quad \text{AND} \quad 2x < -2$$

$$-\frac{5}{2} < x \quad \text{AND} \quad x < -1$$

$$-\frac{5}{2} < x < -1$$

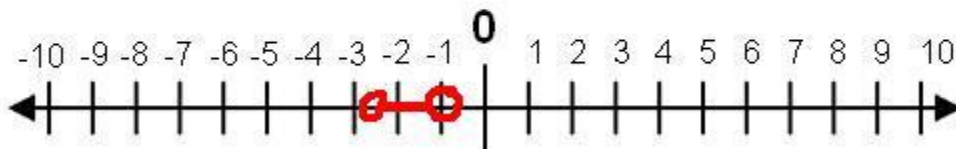

22. $3x + 2 \leq 10$	OR	$3x + 2 \geq 15$
$3x \leq 8$	OR	$3x \geq 13$
$x \leq \frac{8}{3}$	OR	$x \geq \frac{13}{3}$

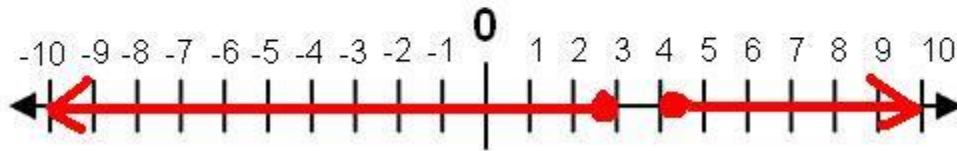

23. $4x - 1 \geq 7$	OR	$\frac{9x}{2} < 3$
$4x \geq 8$	OR	$9x < 6$
$x \geq 2$	OR	$x < \frac{2}{3}$

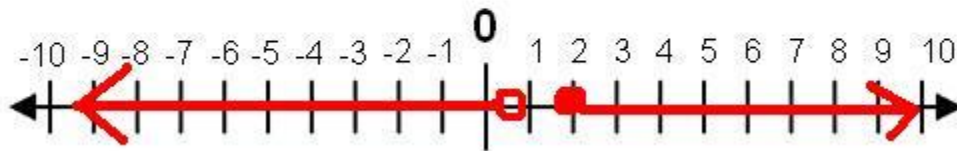

24. $3 - x < -4$	OR	$3 - x > 10$
$-x < -7$	OR	$-x > 7$
$x > 7$	OR	$x < -7$

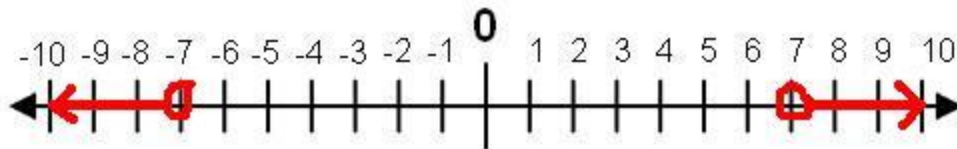

25. $2x - 7 \leq -3$	OR	$2x - 3 > 11$
$2x \leq 4$	OR	$2x > 14$
$x \leq 2$	OR	$x > 7$

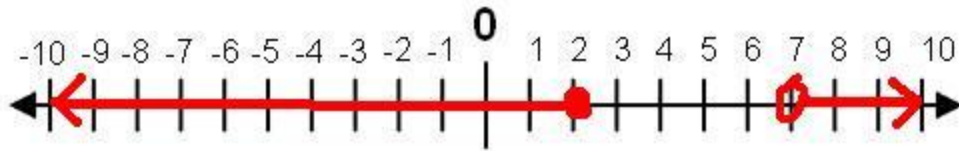

26. $-6d > 48$	OR	$10 + d > 11$
$d < -8$	OR	$d > 1$

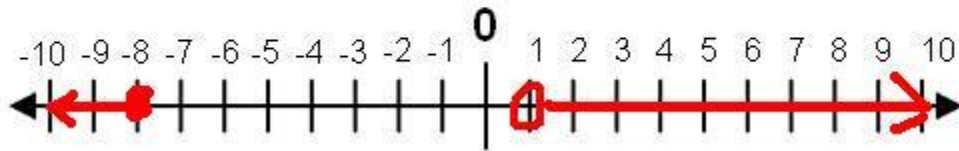

27. $6 + b < 8$	OR	$b + 6 \geq 6$
$b < 2$	OR	$b \geq 0$

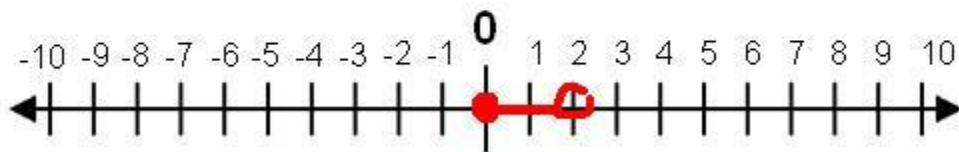

$$\begin{array}{lll}
 28. \quad 4x + 3 < 9 & \text{OR} & -5x + 4 \leq -12 \\
 \quad 4x < 6 & \text{OR} & -5x \leq -16 \\
 \quad x < \frac{3}{2} & \text{OR} & x \geq \frac{16}{5}
 \end{array}$$

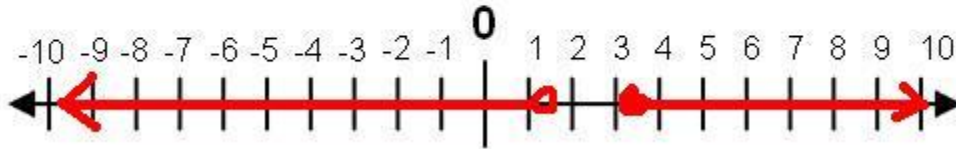

$$\begin{array}{lll}
 29. \quad 50 \leq -32t + 80 \leq 60 & & \\
 \quad 50 \leq -32t + 80 & \text{AND} & -32t + 80 \leq 60 \\
 \quad -30 \leq -32t & \text{AND} & -32t \leq -20 \\
 \quad 0.9375 \geq t & \text{AND} & t \geq 0.625 \\
 & & 0.625 \leq t \leq 0.9375
 \end{array}$$

The ball will have a velocity of between 50 and 60 ft/sec from 0.625 seconds and 0.9375 seconds.

$$\begin{array}{lll}
 30. \quad 16 \leq \frac{40t}{15} \leq 18 & & \\
 \quad 16 \leq \frac{40t}{15} & \text{AND} & \frac{40t}{15} \leq 18 \\
 \quad 240 \leq 40t & \text{AND} & 40t \leq 270 \\
 \quad 6 \leq t & \text{AND} & t \leq 6.75
 \end{array}$$

William can drive for 6 to 6.75 hours.

$$\begin{array}{lll}
 31. \quad 80 \leq \frac{92 + 78 + 85 + x}{4} < 90 & & \\
 \quad 80 \leq \frac{92 + 78 + 85 + x}{4} & \text{AND} & \frac{92 + 78 + 85 + x}{4} < 90 \\
 \quad 320 \leq 255 + x & \text{AND} & 255 + x < 360 \\
 \quad 65 \leq x & \text{AND} & x < 105
 \end{array}$$

Stacey can make between a 65 and 105 to get a B.

$$32. \frac{x+3}{2} < -4$$

$$x+3 < -4$$

$$x < -7$$

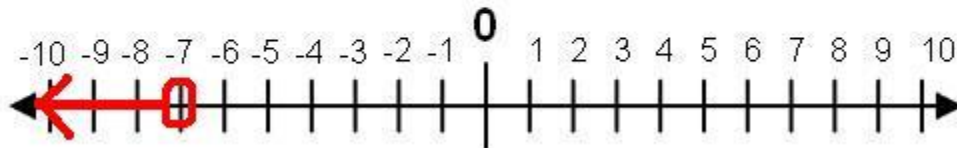

$$33. 2x - 2y = 6$$

$$2x = 6$$

$$-2y = 6$$

$$x = 3$$

$$y = -3$$

$$(3, 0)$$

$$(0, -3)$$

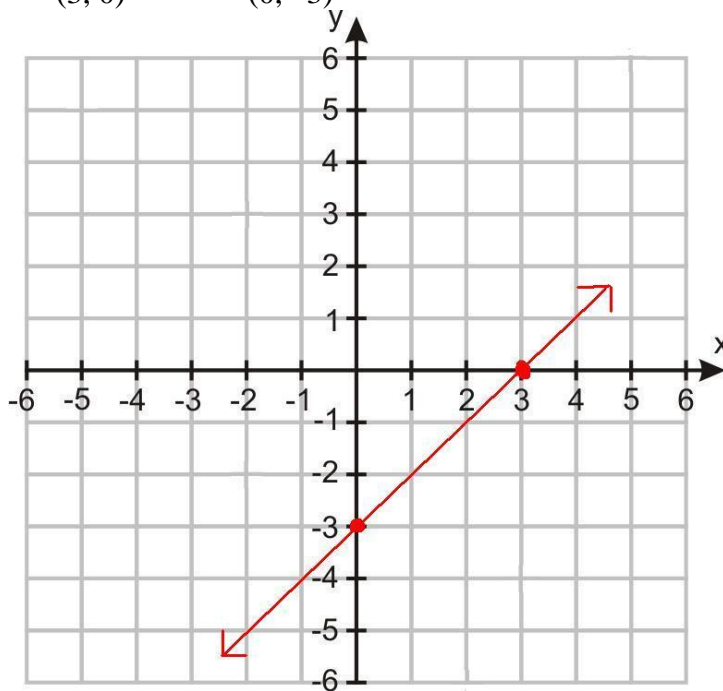

$$34. y + 1 = \frac{2}{5}(x - 5)$$

$$y + 1 = \frac{2}{5}x - 2$$

$$y = \frac{2}{5}x - 3$$

$$\text{Slope} = \frac{2}{5}; y\text{-intercept} = -3$$

$$35. \frac{3 \text{ feet}}{1 \text{ foot}} = \frac{16 \text{ feet}}{x \text{ feet}}$$

$$3x = 16$$

$$x = 5.333 \text{ feet}$$

$$36. 1.99x > 16.99$$

$$x > 8.538$$

George will pay less than Sheri when she watches 9 movies or more.

$$37. -2\frac{1}{5} \div 1\frac{3}{4} = -\frac{11}{5} \div \frac{7}{4} = -\frac{11}{5} \left(\frac{4}{7}\right) = -\frac{44}{35} \text{ OR } -1\frac{9}{35}$$

38. The slope of the line represented by $y = 5x - 2$ is 5. Therefore the slope of the new line must also be 5.

$$y - y_1 = m(x - x_1)$$

$$y - 1 = 5(x - 1)$$

$$y - 1 = 5x - 5$$

$$y = 5x - 4$$

Lesson 6.5

1. $|250| = 250$

2. $|-12| = 12$

3. $\left|-\frac{2}{5}\right| = \frac{2}{5}$

4. $\left|\frac{1}{10}\right| = \frac{1}{10}$

5. $|12 - (-11)| = |23| = 23$

6. $|5 - 22| = |-17| = 17$

7. $|-9 - (-18)| = |9| = 9$

8. $|-2 - 3| = |-5| = 5$

9. $\left|\frac{2}{3} - (-11)\right| = \left|\frac{2}{3} + \frac{33}{3}\right| = \left|\frac{35}{3}\right| = \frac{35}{3}$ OR $11\frac{2}{3}$

10. $|-10.5 - (-9.75)| = |-0.75| = 0.75$

11. $|36 - 14| = |22| = 22$

12. $|x - 5| = 10$

$x - 5 = 10$

$x = 15$

OR

$x - 5 = -10$

OR

$x = -5$

13. $|5r - 6| = 9$

$5r - 6 = 9$

$5r = 15$

$r = 3$

OR

$5r - 6 = -9$

OR

$5r = -3$

OR

$r = -\frac{3}{5}$

14. $1 = \frac{|6 + 5z|}{5}$

$5 = 6 + 5z$

$-1 = 5z$

$z = -\frac{1}{5}$

OR

$-5 = 6 + 5z$

OR

$-11 = 5z$

OR

$z = -\frac{11}{5}$

15. $|8x| = 32$
 $8x = 32$ OR $8x = -32$
 $x = 4$ OR $x = -4$
16. $\left|\frac{m}{8}\right| = 1$
 $\frac{m}{8} = 1$ OR $\frac{m}{8} = -1$
 $m = 8$ OR $m = -8$
17. $|x + 2| = 6$
 $x + 2 = 6$ OR $x + 2 = -6$
 $x = 4$ OR $x = -8$
18. $|5x - 2| = 3$
 $5x - 2 = 3$ OR $5x - 2 = -3$
 $5x = 5$ OR $5x = -1$
 $x = 1$ OR $x = -\frac{1}{5}$
19. $51 = |1 - 5b|$
 $51 = 1 - 5b$ OR $-51 = 1 - 5b$
 $50 = -5b$ OR $-52 = -5b$
 $-10 = b$ OR $b = \frac{52}{5}$
20. $8 = 3 + |10y + 5|$
 $5 = |10y + 5|$
 $10y + 5 = 5$ OR $10y + 5 = -5$
 $10y = 0$ OR $10y = -10$
 $y = 0$ OR $y = -1$
21. $|4x - 1| = 19$
 $4x - 1 = 19$ OR $4x - 1 = -19$
 $4x = 18$ OR $4x = -20$
 $x = \frac{9}{2}$ OR $x = -5$
22. $8|x + 6| = -48$
 $|x + 6| = -6$
 NO SOLUTION because absolute value cannot equal a negative value.
23. The vertex and the fact that it is symmetrical.
24. Several x -values that would be appropriate are $(-5, -4, -3, -2, -1, 0, 1, 2, 3, 4, 5)$.

25.

x	$y = x + 3 $	y
-6	$y = -6 + 3 = 3$	3
-5	$y = -5 + 3 = 2$	2
-4	$y = -4 + 3 = 1$	1
-3	$y = -3 + 3 = 0$	0
-2	$y = -2 + 3 = 1$	1
-1	$y = -1 + 3 = 2$	2
0	$y = 0 + 3 = 3$	3

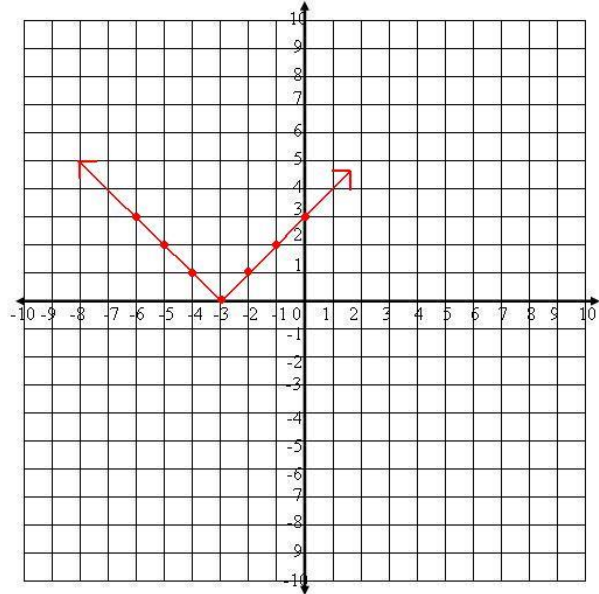

26.

x	$y = x - 6 $	y
3	$y = 3 - 6 = 3$	3
4	$y = 4 - 6 = 2$	2
5	$y = 5 - 6 = 1$	1
6	$y = 6 - 6 = 0$	0
7	$y = 7 - 6 = 1$	1
8	$y = 8 - 6 = 2$	2
9	$y = 9 - 6 = 3$	3

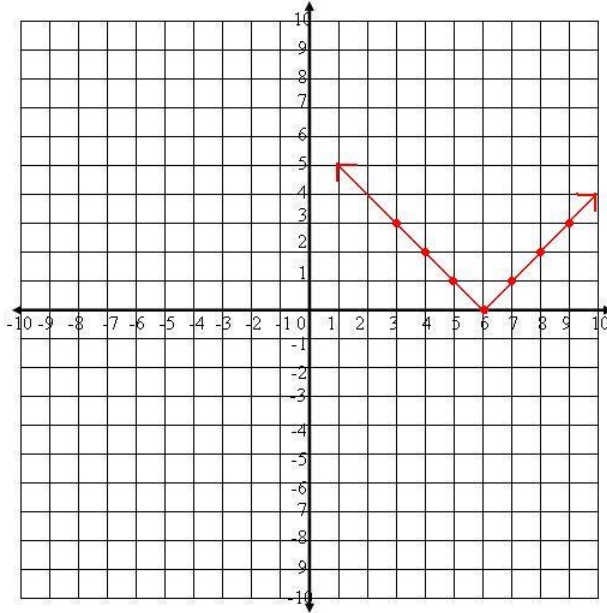

27.

x	$y = 4x + 2 $	y
-3	$y = 4(-3) + 2 = 10$	10
-2	$y = 4(-2) + 2 = 6$	6
-1	$y = 4(-1) + 2 = 2$	2
0	$y = 4(0) + 2 = 2$	2
1	$y = 4(1) + 2 = 6$	6
2	$y = 4(2) + 2 = 10$	10

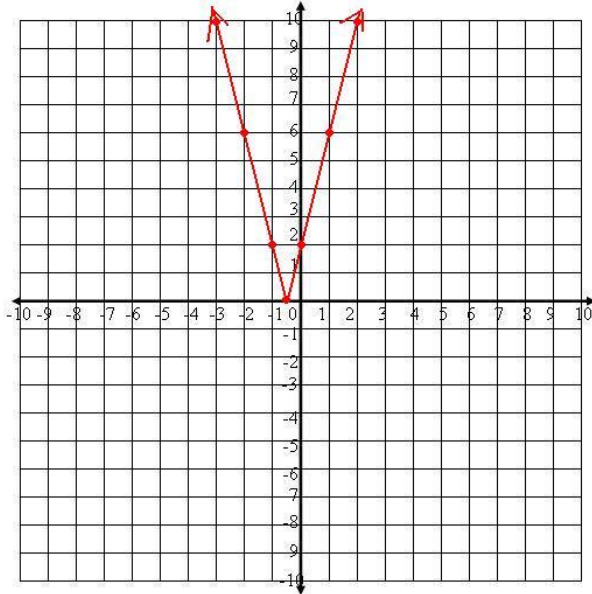

28.

x	$y = \left \frac{x}{3} - 4 \right $	y
18	$y = \left \frac{18}{3} - 4 \right = 2$	2
15	$y = \left \frac{15}{3} - 4 \right = 1$	1
12	$y = \left \frac{12}{3} - 4 \right = 0$	0
9	$y = \left \frac{9}{3} - 4 \right = 1$	1
6	$y = \left \frac{6}{3} - 4 \right = 2$	2
3	$y = \left \frac{3}{3} - 4 \right = 3$	3
0	$y = \left \frac{0}{3} - 4 \right = 4$	4

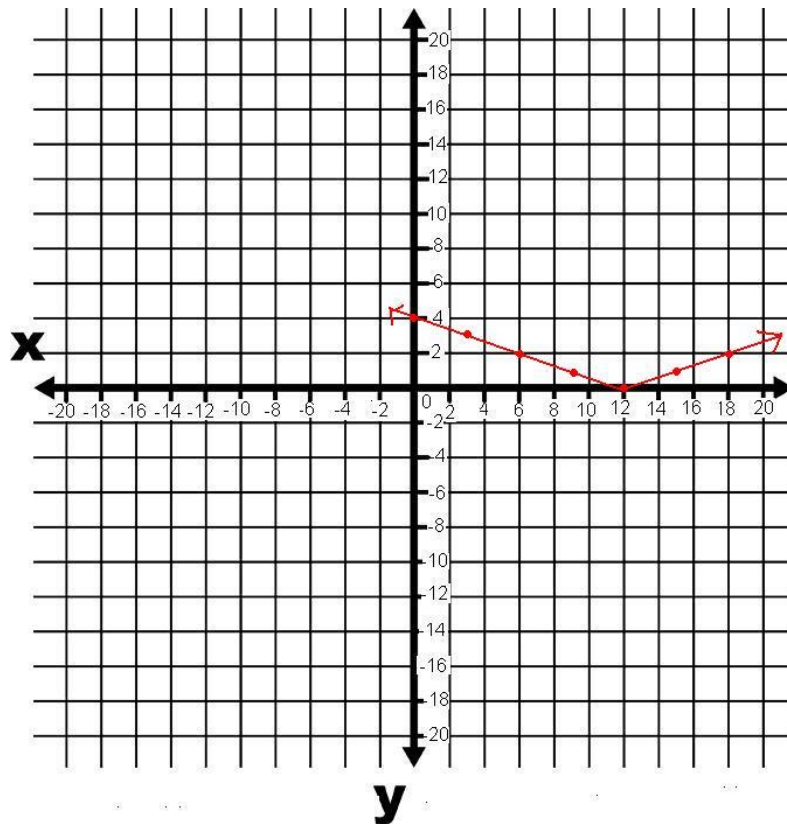

29.

x	$y = x - 4 $	y
7	$y = 7 - 4 = 3$	3
6	$y = 6 - 4 = 2$	2
5	$y = 5 - 4 = 1$	1
4	$y = 4 - 4 = 0$	0
3	$y = 3 - 4 = 1$	1
2	$y = 2 - 4 = 2$	2
1	$y = 1 - 4 = 3$	3
0	$y = 0 - 4 = 4$	4

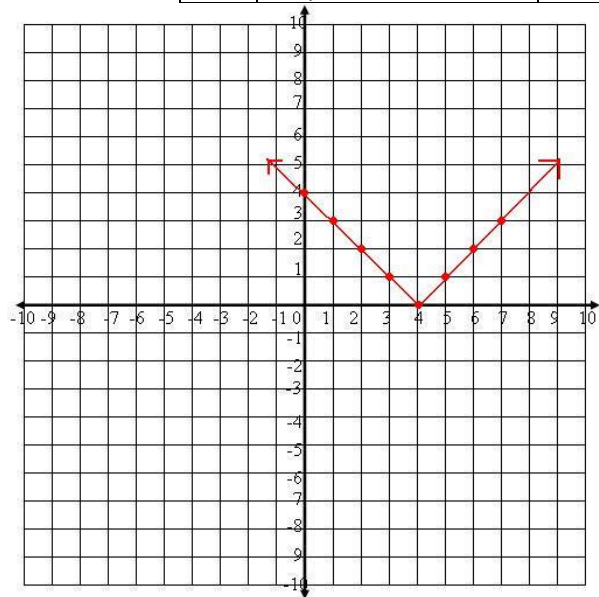

30.

x	$y = - x - 4 $	y
1	$y = - 1 - 4 = -3$	-3
2	$y = - 2 - 4 = -2$	-2
3	$y = - 3 - 4 = -1$	-1
4	$y = - 4 - 4 = 0$	0
5	$y = - 5 - 4 = -1$	-1
6	$y = - 6 - 4 = -2$	-2
7	$y = - 7 - 4 = -3$	-3
8	$y = - 8 - 4 = -4$	-4

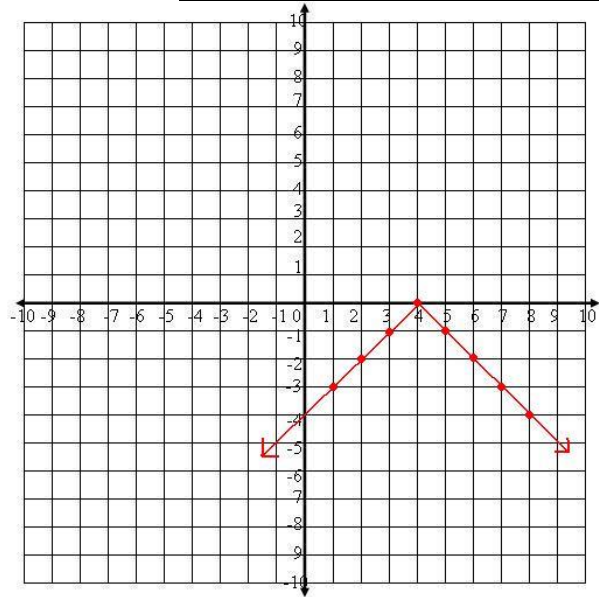

31.

x	$y = x - 2$	y
-3	$y = -3 - 2 = 1$	1
-2	$y = -2 - 2 = 0$	0
-1	$y = -1 - 2 = -1$	-1
0	$y = 0 - 2 = -2$	-2
1	$y = 1 - 2 = -1$	-1
2	$y = 2 - 2 = 0$	0
3	$y = 3 - 2 = 1$	1

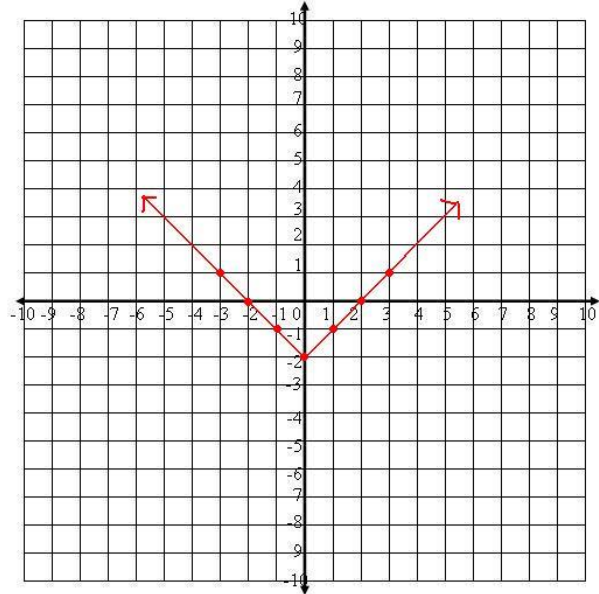

32.

x	$y = x + 3$	y
-3	$y = -3 + 3 = 6$	6
-2	$y = -2 + 3 = 5$	5
-1	$y = -1 + 3 = 4$	4
0	$y = 0 + 3 = 3$	3
1	$y = 1 + 3 = 4$	4
2	$y = 2 + 3 = 5$	5
3	$y = 3 + 3 = 6$	6

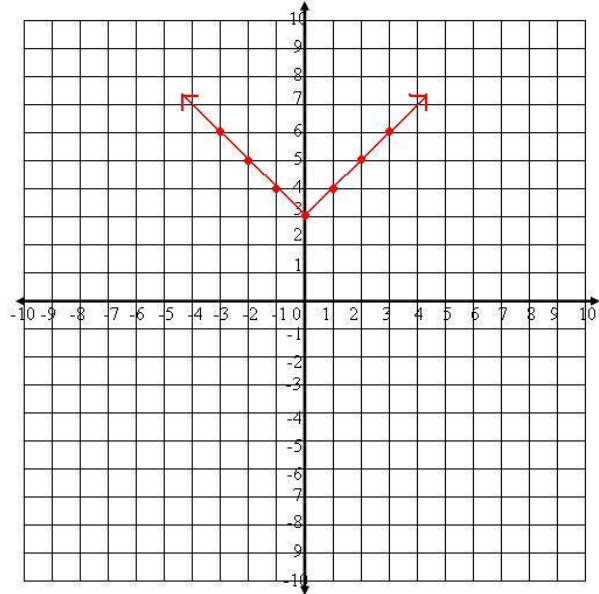

33.

x	$y = \frac{1}{2} x $	y
-6	$y = \frac{1}{2} -6 = 3$	3
-4	$y = \frac{1}{2} -4 = 2$	2
-2	$y = \frac{1}{2} -2 = 1$	1
0	$y = \frac{1}{2} 0 = 0$	0
2	$y = \frac{1}{2} 2 = 1$	1
4	$y = \frac{1}{2} 4 = 2$	2
6	$y = \frac{1}{2} 6 = 3$	3

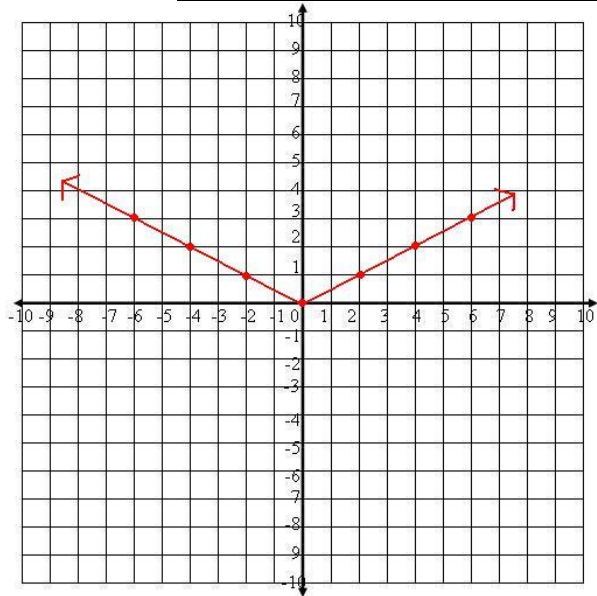

34.

x	$y = 4 x - 2$	y
-3	$y = 4 -3 - 2 = 10$	10
-2	$y = 4 -2 - 2 = 6$	6
-1	$y = 4 -1 - 2 = 2$	2
0	$y = 4 0 - 2 = -2$	-2
1	$y = 4 1 - 2 = 2$	2
2	$y = 4 2 - 2 = 6$	6
3	$y = 4 3 - 2 = 10$	10

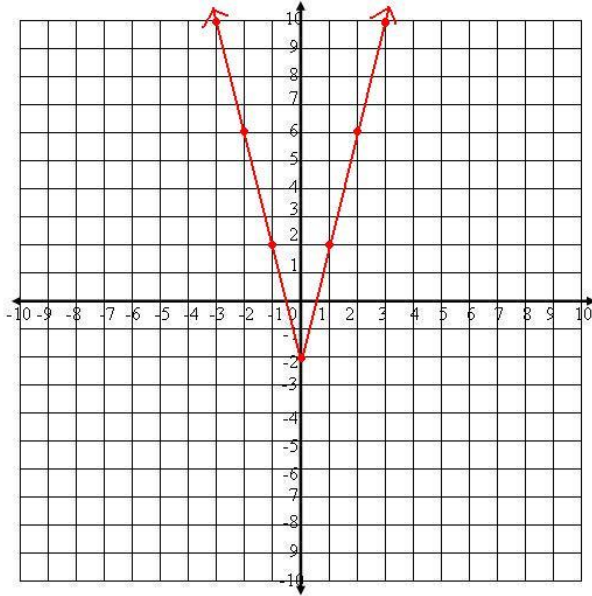

35.

x	$y = \left \frac{1}{2}x \right + 6$	y
-6	$y = \left \frac{1}{2}(-6) \right + 6 = 9$	9
-4	$y = \left \frac{1}{2}(-4) \right + 6 = 8$	8
-2	$y = \left \frac{1}{2}(-2) \right + 6 = 7$	7
0	$y = \left \frac{1}{2}(0) \right + 6 = 6$	6
2	$y = \left \frac{1}{2}(2) \right + 6 = 7$	7
4	$y = \left \frac{1}{2}(4) \right + 6 = 8$	8
6	$y = \left \frac{1}{2}(6) \right + 6 = 9$	9

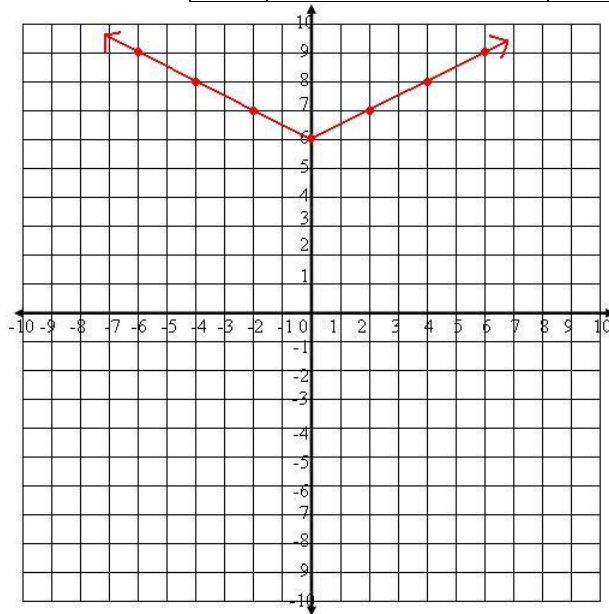

36. The shortest ruler that will pass is $12 - \frac{1}{32} = 11\frac{31}{32}$ inches. The longest ruler that will pass is $12 + \frac{1}{32} = 12\frac{1}{32}$.

37. $6t - 14 < 2t + 7$
 $4t < 21$
 $t < \frac{21}{4}$

38. Let s = the speed of the truck.
 Then $45 \leq s \leq 65$.



39. Let x = the amount for gas.
 Then $181 + 25 + x \leq 276$
 $206 + x \leq 276$
 $x \leq 70$
 Lloyd can afford \$70 for gas.

40. $\sqrt{12} \times \sqrt{3} = \sqrt{36} = 6$

41. $\frac{3.4 \text{ ounces}}{8 \text{ hushpuppies}} = \frac{x \text{ ounces}}{56 \text{ hushpuppies}}$

$8x = 190.4$
 $x = 23.8 \text{ ounces}$

42. The additive inverse of 124 is -124 .

43. The multiplicative inverse of 14 is $\frac{1}{14}$.

44. Addition Property of Equality – allows you to apply the same operation to each side of the equation, or “what you do to one side of an equation you can do to the other.” (page 86)

Lesson 6.6

1. $|a + 1| \leq 4$ breaks down into $a + 1 \leq 4$ OR $a + 4 \geq -4$.

2. $|x| \leq 6$
 $x \leq 6$ OR $x \geq -6$

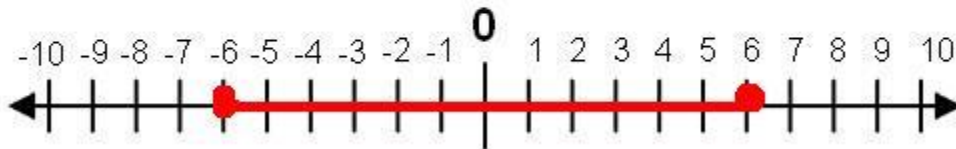

3. $4 \leq |a + 4|$ can be re-written as $|a + 4| \geq 4$
 $a + 4 \geq 4$ OR $a + 4 \leq -4$
 $a \geq 0$ OR $a \leq -8$

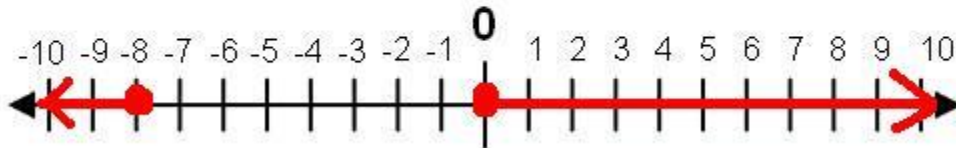

4. $|x| > 3.5$
 $x > 3.5$ OR $x < -3.5$

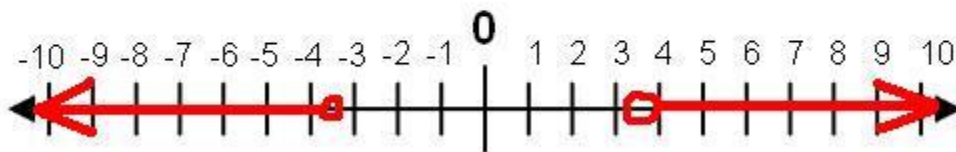

5. $6 > |10b + 6|$ can be re-written as $|10b + 6| < 6$
 $10b + 6 < 6$ OR $10b + 6 > 6$
 $10b < 0$ OR $10b > 0$
 $b < 0$ OR $b > 0$

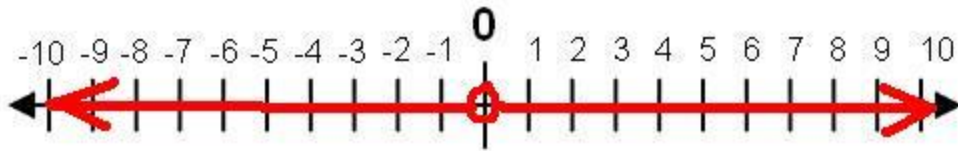

6. $|x| < 12$
 $x < 12$ OR $x > -12$

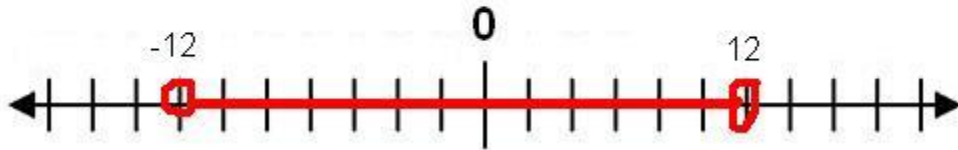

7. $\left| \frac{w}{10} \right| < 2$
 $\frac{w}{10} < 2$ OR $\frac{w}{10} > -2$
 $w < 20$ OR $w > -20$

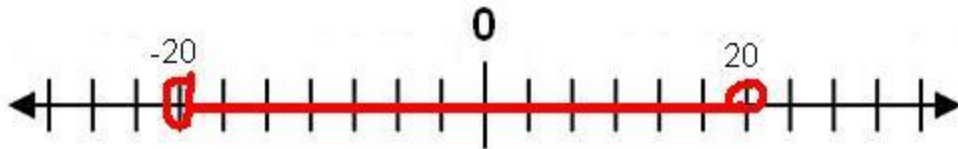

$$8. \left| \frac{x}{5} \right| \leq 6$$

$$\frac{x}{5} \leq 6$$

$$x \leq 30$$

OR

$$\frac{x}{5} \geq -6$$

OR

$$x \geq -30$$

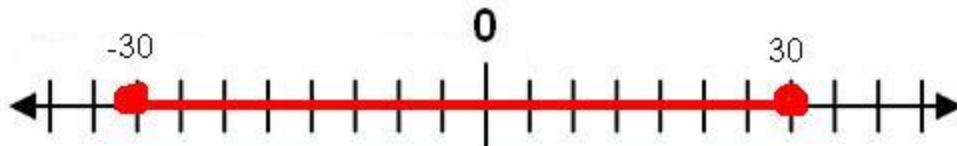

$$9. |7x| \geq 21$$

$$7x \geq 21$$

$$x \geq 3$$

OR

$$7x \leq -21$$

OR

$$x \leq -3$$

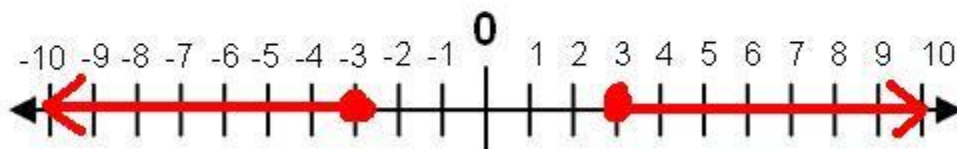

$$10. |6c + 5| < 47$$

$$6c + 5 < 47$$

$$6c < 42$$

$$c < 7$$

OR

$$6c + 5 > -47$$

$$6c > -52$$

OR

$$c > -\frac{26}{3} \text{ which is } -8\frac{2}{3}$$

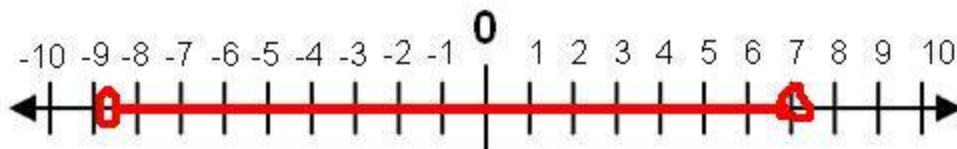

$$11. |x - 5| > 8$$

$$x - 5 > 8$$

$$x > 13$$

OR

$$x - 5 < -8$$

$$x < -3$$

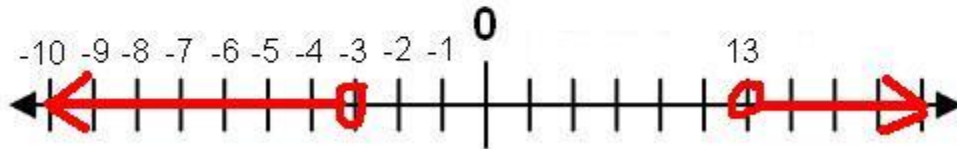

$$12. |x + 7| < 3$$

$$x + 7 < 3$$

$$x < -4$$

OR

$$x + 7 > -3$$

$$x > -10$$

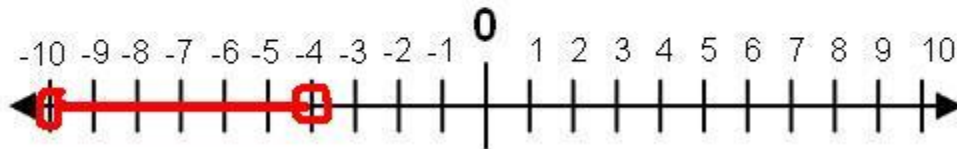

$$13. \left| x - \frac{3}{4} \right| \leq \frac{1}{2}$$

$$x - \frac{3}{4} \leq \frac{1}{2}$$

$$x \leq \frac{1}{2} + \frac{3}{4}$$

$$x \leq \frac{5}{4}$$

OR

$$x - \frac{3}{4} \geq -\frac{1}{2}$$

$$x \geq -\frac{1}{2} + \frac{3}{4}$$

$$x \geq \frac{1}{4}$$



$$14. |2x - 5| \geq 13$$

$$2x - 5 \geq 13$$

$$2x \geq 18$$

$$x \geq 9$$

OR

$$2x - 5 \leq -13$$

$$2x \leq -8$$

$$x \leq -4$$

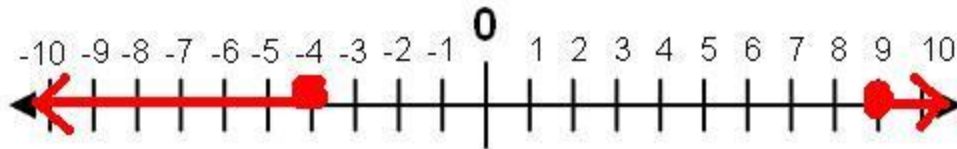

$$15. |5x + 3| < 7$$

$$5x + 3 < 7$$

$$5x < 4$$

$$x < \frac{4}{5}$$

OR

$$5x + 3 > -7$$

$$5x > -10$$

$$x > -2$$

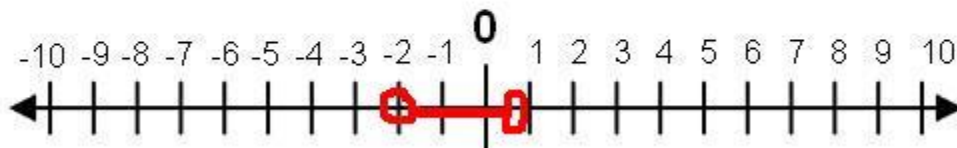

$$16. \left| \frac{x}{3} - 4 \right| \leq 2$$

$$\frac{x}{3} - 4 \leq 2$$

$$\frac{x}{3} \leq 6$$

$$x \leq 18$$

OR

$$\frac{x}{3} - 4 \geq -2$$

$$\frac{x}{3} \geq -2$$

$$x \geq -6$$

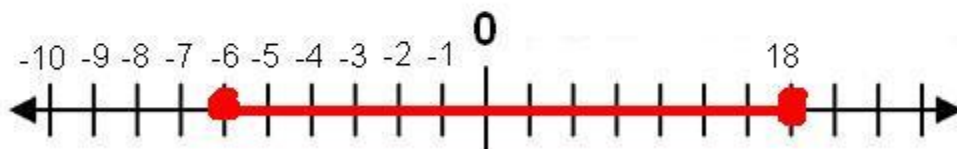

$$17. \left| \frac{2x}{7} + 9 \right| > \frac{5}{7}$$

$$\begin{array}{l} \frac{2x}{7} + 9 > \frac{5}{7} \\ 2x + 63 > 5 \\ 2x > -58 \\ x > -29 \end{array} \quad \text{OR} \quad \begin{array}{l} \frac{2x}{7} + 9 < -\frac{5}{7} \\ 2x + 63 < -5 \\ 2x < -68 \\ x < -34 \end{array}$$

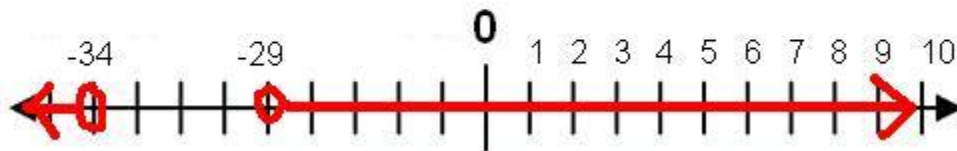

$$18. |-6t + 3| + 9 \geq 18$$

$$\begin{array}{l} |-6t + 3| \geq 9 \\ -6t + 3 \geq 9 \\ -6t \geq 6 \\ t \leq -1 \end{array} \quad \text{OR} \quad \begin{array}{l} -6t + 3 \leq -9 \\ -6t \leq -12 \\ t \geq -2 \end{array}$$

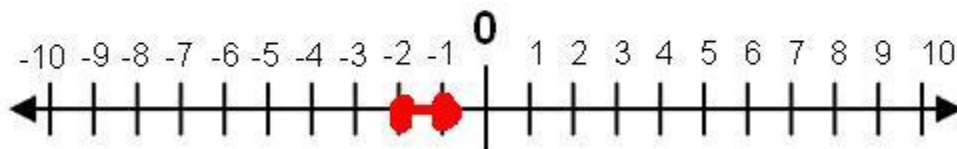

$$19. |9p + 5| > 23$$

$$\begin{array}{l} 9p + 5 > 23 \\ 9p > 18 \\ p > 2 \end{array} \quad \text{OR} \quad \begin{array}{l} 9p + 5 < -23 \\ 9p < -28 \\ p < -\frac{28}{9} \end{array}$$

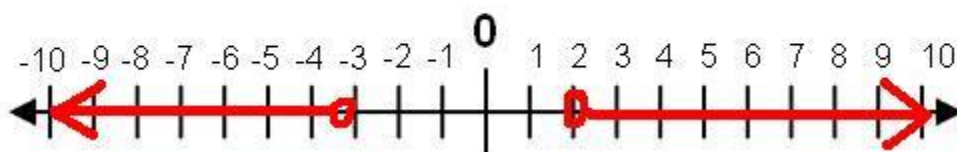

$$20. |-2s - 4| \leq 6$$

$$-2s - 4 \leq 6$$

$$-2s \leq 10$$

$$s \geq -5$$

OR

OR

OR

$$-2s - 4 \geq -6$$

$$-2s \geq -2$$

$$s \leq 1$$

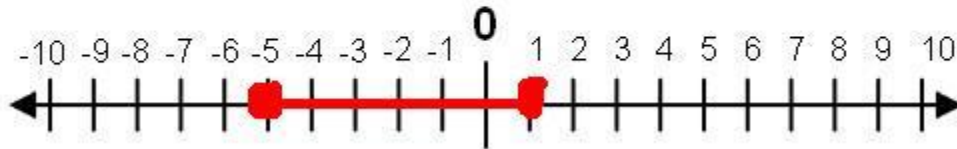

$$21. \frac{|10m - 5|}{8} > 5$$

$$|10m - 5| > 40$$

$$10m - 5 > 40$$

$$10m > 45$$

$$m > 4.5$$

OR

OR

OR

$$10m - 5 < -40$$

$$10m < -35$$

$$m < -3.5$$

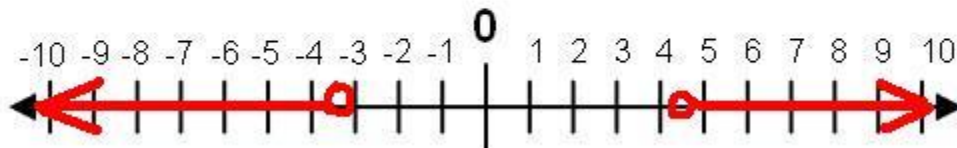

22. Let a = the average weight of a baby boy.

$$|a - 13| \leq 2.5$$

$$a - 13 \leq 2.5$$

$$a \leq 15.5$$

OR

OR

$$a - 13 \geq -2.5$$

$$a > 10.5$$

A three-month old baby boy is healthy if he weighs between 10.5 and 15.5 pounds.

$$23. |7u| = 77$$

$$7u = 77$$

$$u = 11$$

OR

OR

$$7u = -77$$

$$u = -11$$

$$24. \frac{2 \text{ inches}}{125 \text{ miles}} = \frac{x \text{ inches}}{945 \text{ miles}}$$

$$125x = 1890$$

$$x = 15.12 \text{ inches}$$

25. Domain: $\{-9, -6, -4, 0, 3, 5\}$
Range: $\{0\}$

26. Yes, the relation in #25 is a function because each value in the domain belongs to only one value in the range.

27. Either method works. Since 3 is multiplied with everything inside the parentheses, one can simply divide both sides by that number.

$$\begin{aligned} 28. \quad 4x &= 6 & y &= 6 \\ x &= \frac{3}{2} & (0, 6) \\ \left(\frac{3}{2}, 0\right) \end{aligned}$$

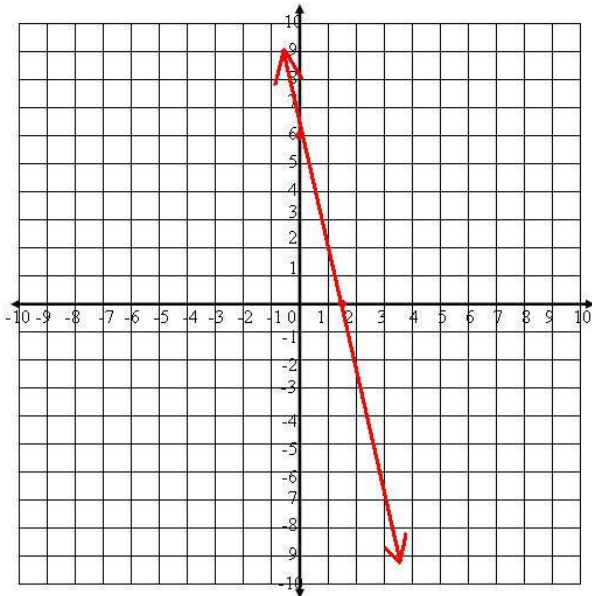

$$29. \quad \frac{3}{30} = \frac{1}{10} = 0.10$$

$$30. \quad -5\frac{2}{3} \div \frac{71}{8} = -\frac{17}{3} \div \frac{71}{8} = -\frac{17}{3} \left(\frac{8}{71}\right) = -\frac{136}{213}$$

Lesson 6.7

1. The space on either side of a graphed line (boundary line) is called a half-plane.
2. A dashed line is used when graphing linear inequalities with either " $<$ " or " $>$ ".
3. A dashed line is used when graphing linear inequalities with either " \leq " or " \geq ".
4. Look at the inequality sign to determine if you should shade above the line or below the line.
- 5.

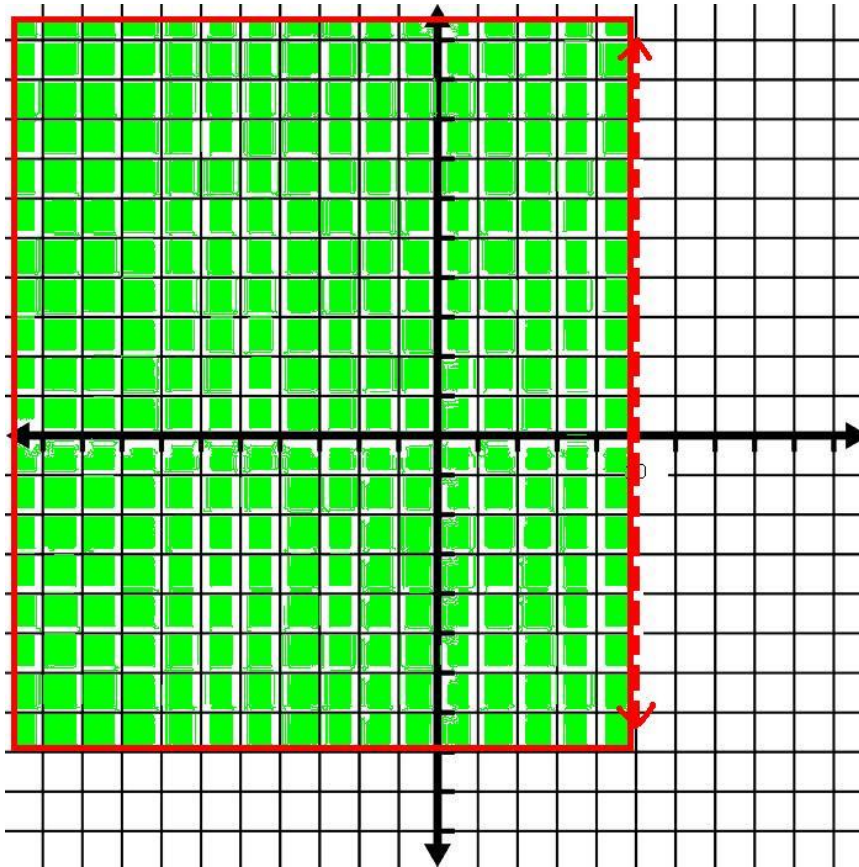

6. e

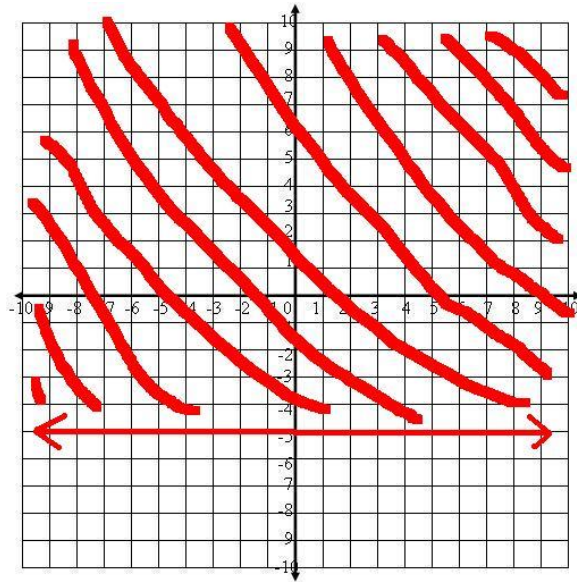

7. e

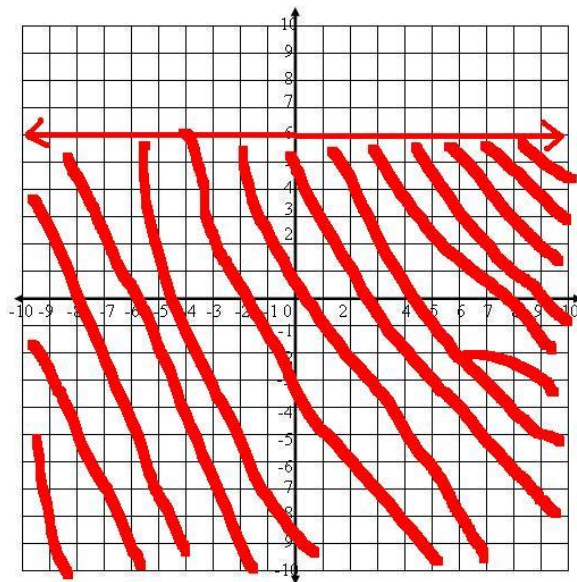

8. $|x| > 10$

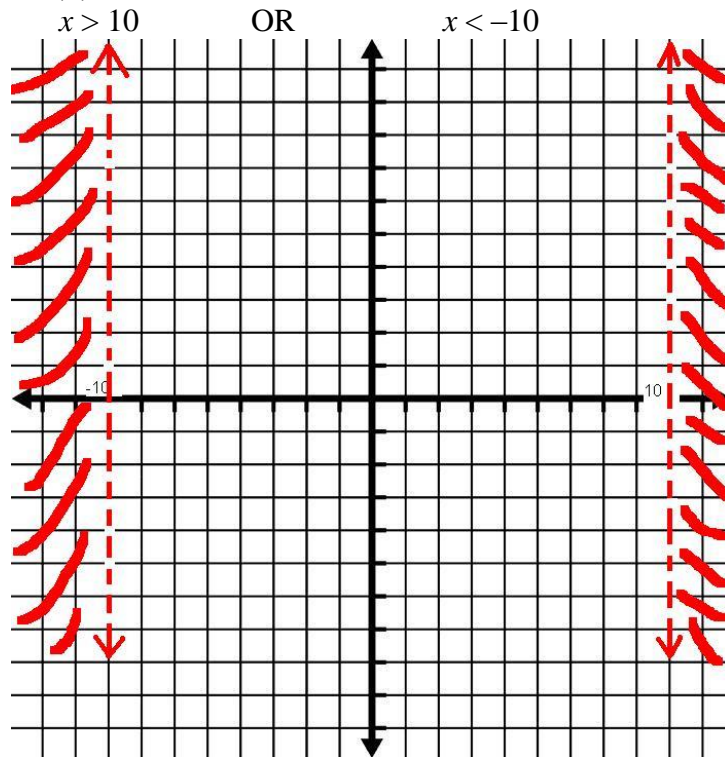

9. $|y| \leq 7$
 $y \leq 7$

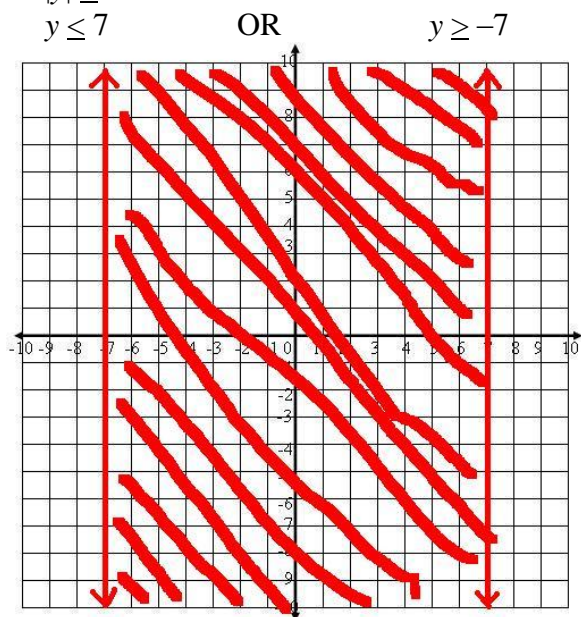

10. s

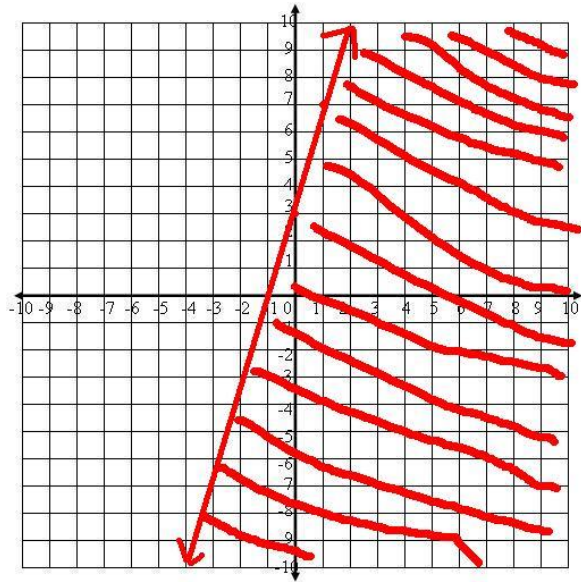

11. s

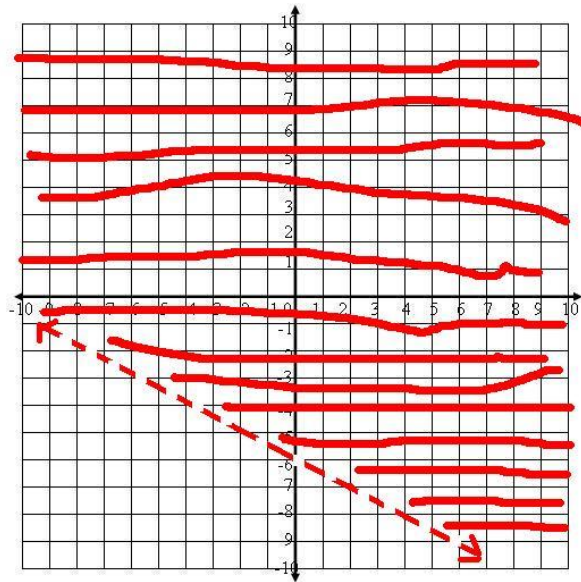

12. s

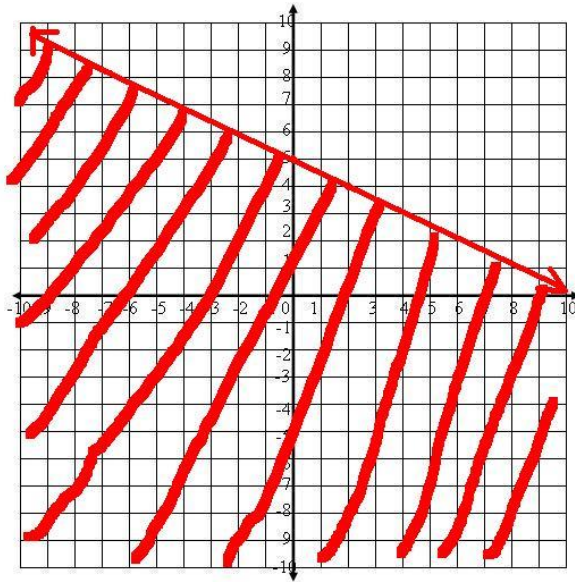

$$13. 3x - 4y \geq 12$$
$$-4y \geq -3x + 12$$
$$y \leq \frac{3}{4}x - 3$$

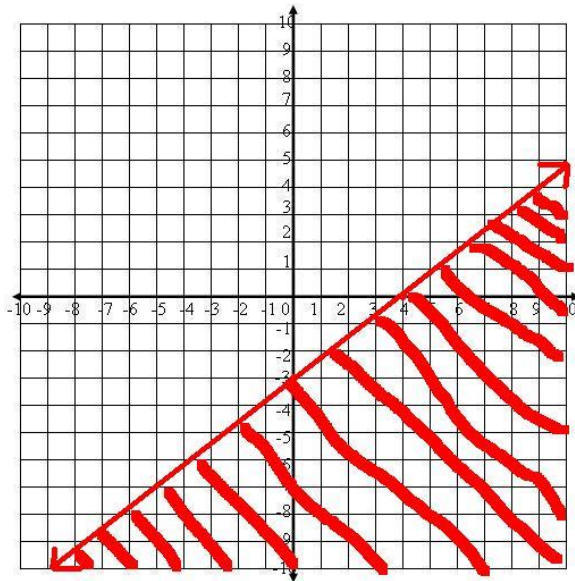

$$14. x + 7y < 5$$
$$7y < -x + 5$$
$$y < -\frac{1}{7}x + \frac{5}{7}$$

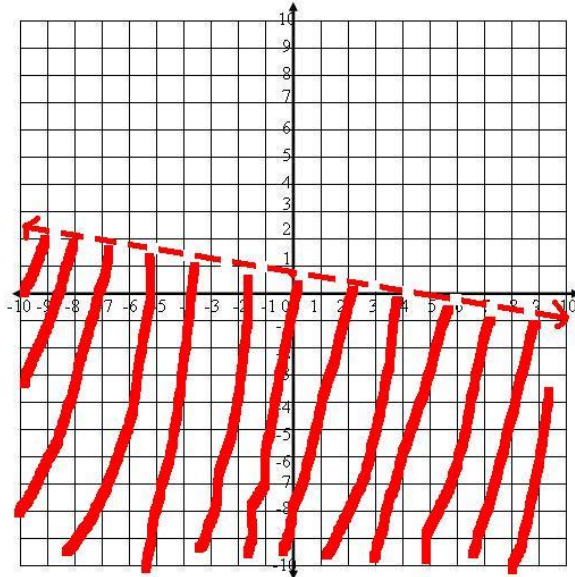

$$15. y < -4x + 4$$

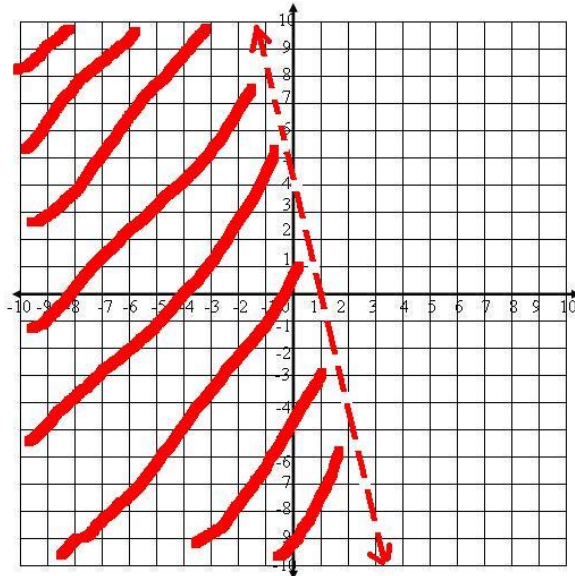

$$16. y > \frac{7}{2}x + 3$$

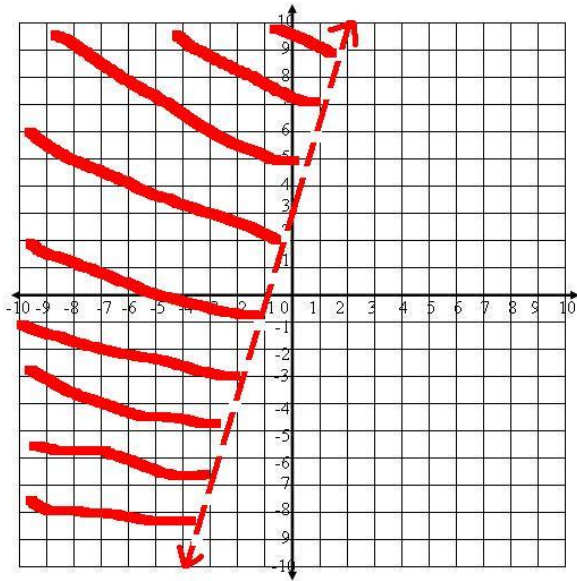

$$17. 6x + 5y > 1$$
$$5y > -6x + 1$$
$$y > -\frac{6}{5}x + \frac{1}{5}$$

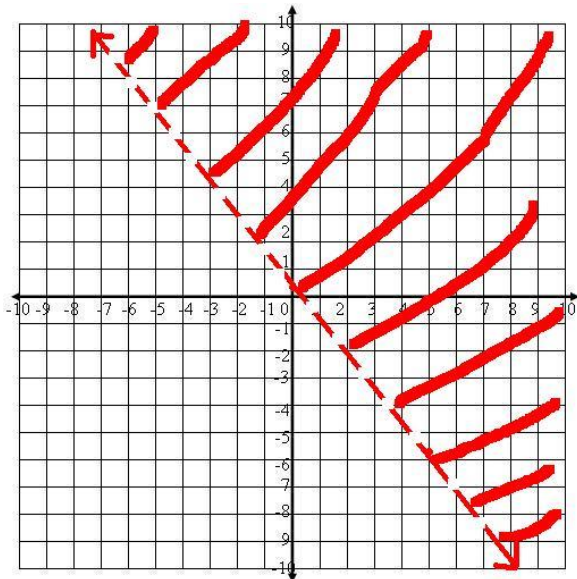

$$18. 6x - 5y \leq 15$$

$$-5y < -6x + 15$$

$$y \geq \frac{6}{5}x - 3$$

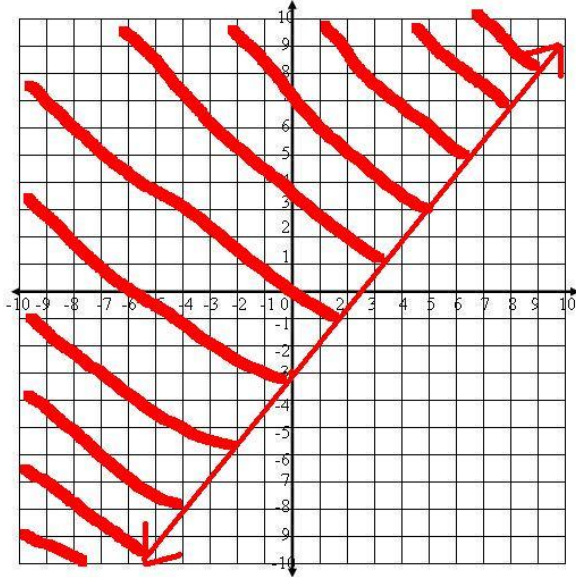

$$19. 2x - y < 5$$

$$-y < -2x + 5$$

$$y > 2x - 5$$

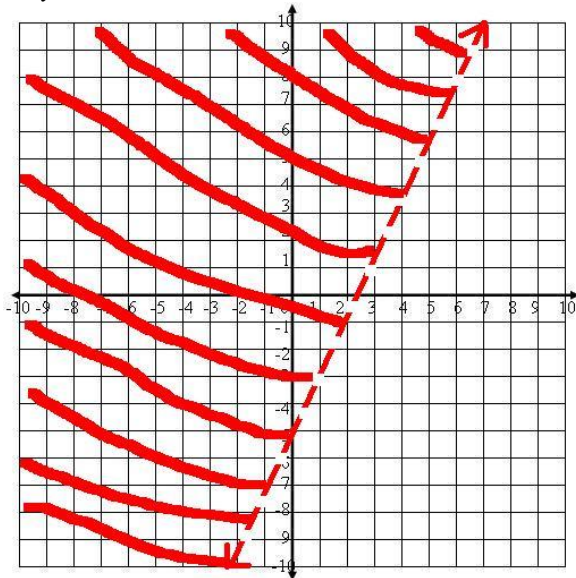

$$20. y + 5 \leq -4x + 10$$

$$y \leq -4x - 5$$

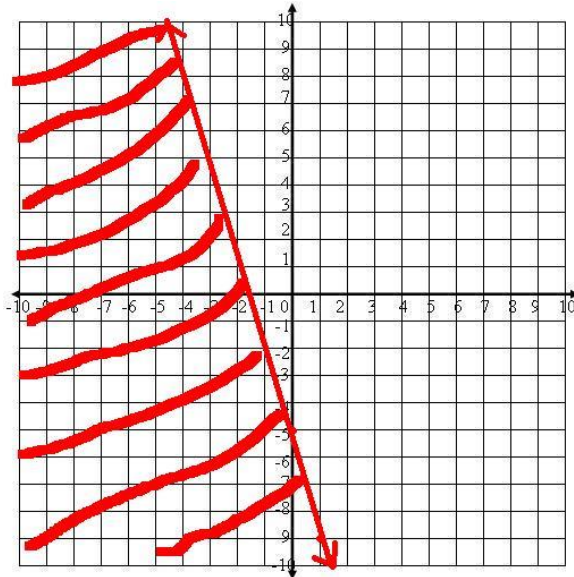

$$21. x - \frac{1}{2}y \geq 5$$

$$-\frac{1}{2}y \geq -x + 5$$

$$y \leq 2x - 10$$

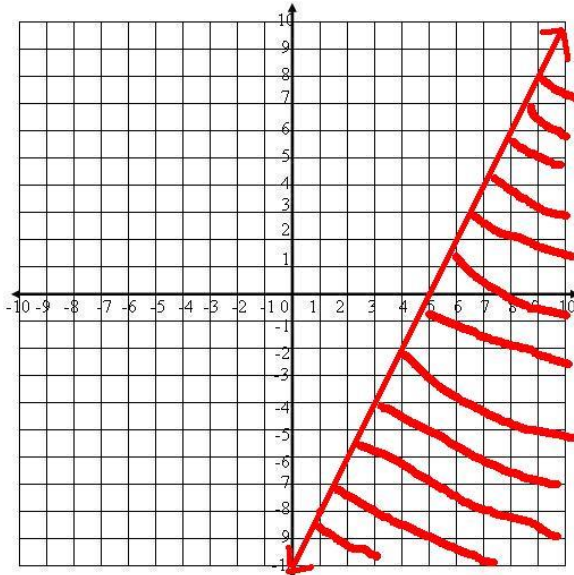

$$22. y + 4 \leq -\frac{x}{3} + 5$$

$$y \leq -\frac{1}{3}x + 1$$

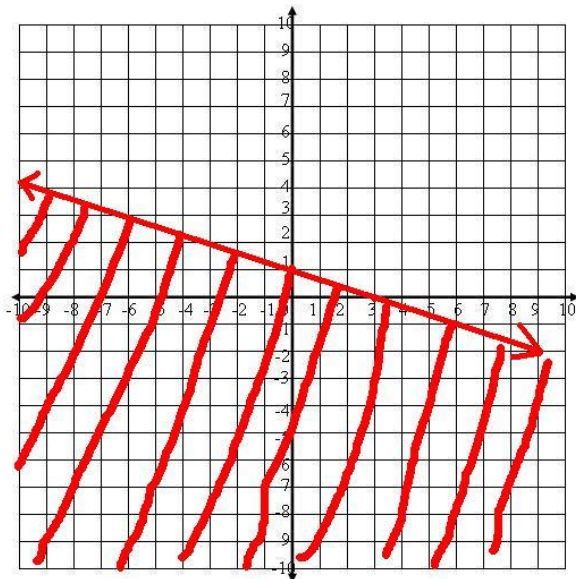

$$23. 5x - 2y > 4$$

$$-2y > -5x + 4$$

$$y < \frac{5}{2}x - 2$$

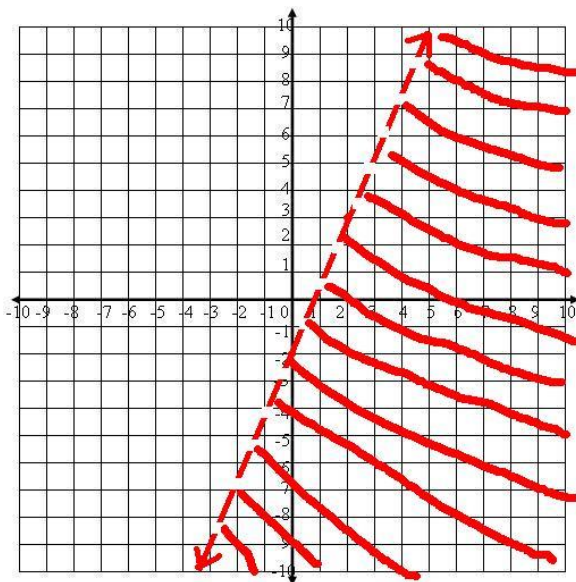

24. $30x + 5y < 100$
 $5y < -30x + 100$
 $y < -6x + 20$

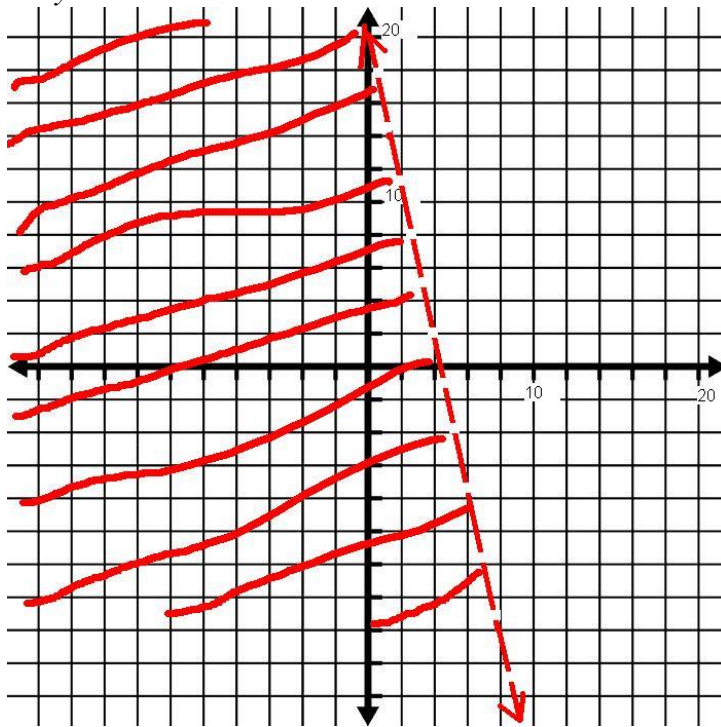

25. $y \geq -x$

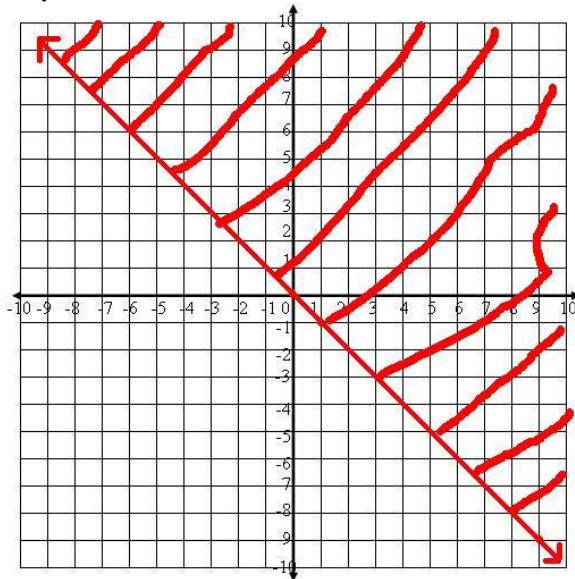

$$26. \begin{aligned} 6x - y &< 4 \\ -y &< -6x + 4 \\ y &> 6x - 4 \end{aligned}$$

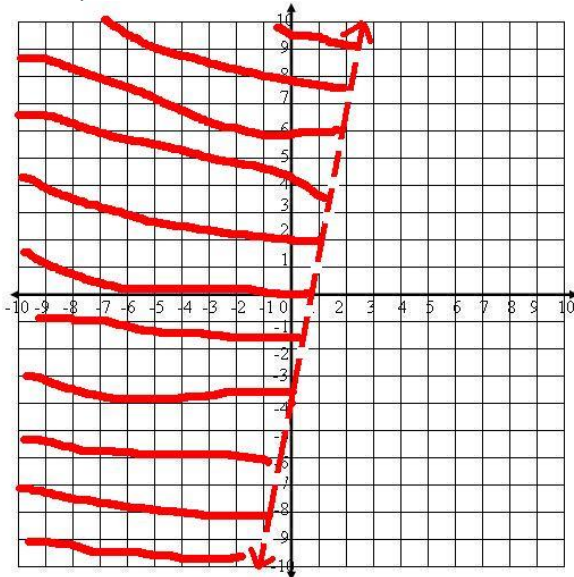

27. Let a = the number ankle bracelets and w = the number of wrist bracelets.

$$\text{Then } 8a + 6w \leq 600$$

$$6w < 8a + 600$$

$$w < \frac{4}{3}a + 100$$

28. Let g = the amount of gold and s = the amount of silver.

$$670g + 13s < 600$$

$$13s < -670g + 600$$

$$s < -51.54g + 46.15$$

29. Let d = daytime minutes and n = nighttime minutes.

$$0.5d + 0.1n > 20.00$$

$$0.1n > -0.5d + 20.00$$

$$n > -5d + 200$$

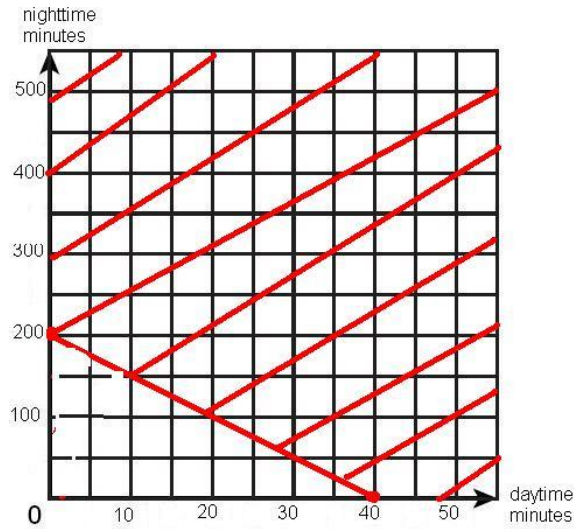

30. Let h = the number of hot dogs and b = the number of burgers.

$$0.75h + 1.25b < 30$$

$$1.25b < -0.75h + 30$$

$$b < -0.6h + 24$$

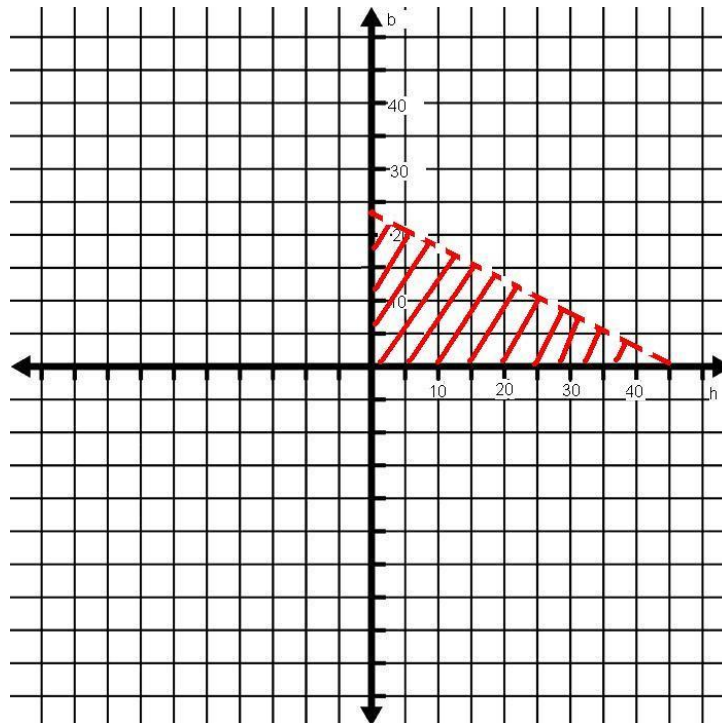

31. Let s = the number of pounds of strawberries and b = the number of pounds of bananas.

$$3.00s + 1.00b \leq 10.00$$

$$1.00b \leq -3.00s + 10.00$$

$$b \leq -3.00s + 10.00$$

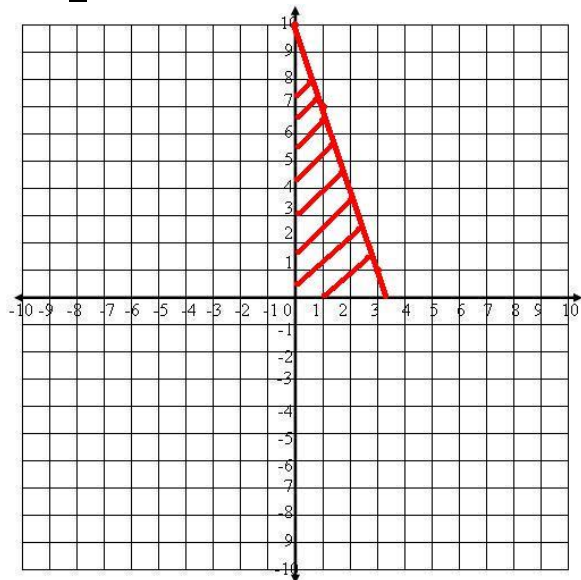

32. $y = 3|x - 3|$

x	y
-3	18
-2	15
-1	12
3	0
8	15
9	18
10	21

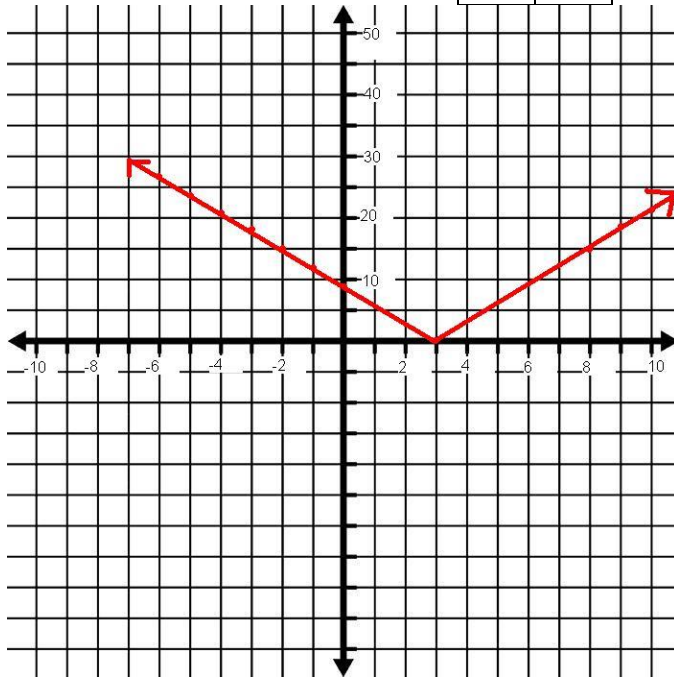

33. $y = \frac{5}{4}x - 2$

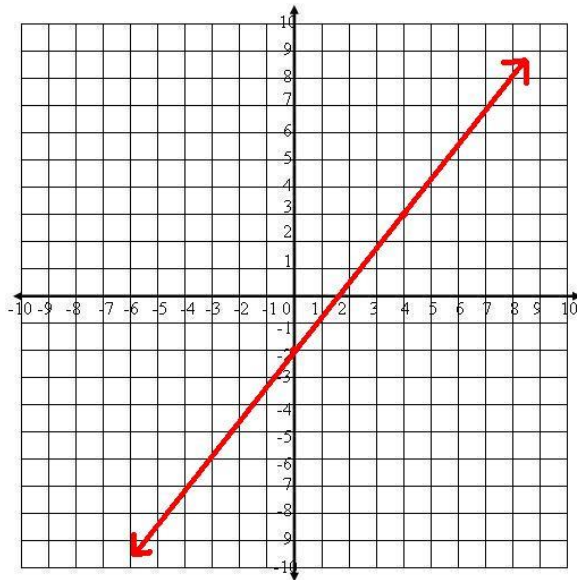

34. What is 14.75% of 29?

$$x = 0.1475(29) = 4.2775$$

35. New price = 31.99, percent change = 15% or 0.15

31.99 is 115% of what number?

$$31.99 = 1.15x$$

$$x = \$27.82$$

The original price was \$27.82.

36. $F(16) = 1.8(16) + 32 = 60.8^\circ\text{F}$

37. Let C = the number of apples Charlene has. Then $C = 36 + 18 = 54$.
Charlene has 54 apples.

38. The possible outcomes are Head and Tails.

39. There are 360° in a circle.

Lesson 6.8

- The experimental probability is the ratio of the proposed outcome to the number of trials of the experiment (page 254-255).
- Theoretical probability is what one thinks will happen before an event occurs while experimental probability is what actually happens during an event.
-

Fraction	Decimal	Percent
$\frac{49}{50}$	0.98	98%
$\frac{3}{200}$	0.015	1.5%
$\frac{1}{16}$	0.0625	6.25%
$\frac{2}{3}$	$0.\bar{6}$	$66.\bar{6}\%$
$\frac{31}{50}$	0.62	62%
$\frac{73}{100}$	0.73	73%

- The sample space is {1, 2, 3, 4, 5}.

- $P(\text{spinning a 4}) = \frac{1}{5}$

- 3, 2, 4, 3, 5, 2, 2, 4, 3, 3, 2, 5, 4, 2, 3

Spin	1	2	3	4	5	6	7	8	9	10	11	12	13	14	15
Outcome	3	2	4	3	5	2	2	4	3	3	2	5	4	2	3

- $P(\text{spinning a 4}) = \frac{3}{15} = \frac{1}{5}$

- Since there are no spaces labeled “6”, $P(\text{spinning a 6}) = 0$.

- There are 52 values in the sample space. One way to list them is by suit and numerical order.

- $P(\text{king}) = \frac{4}{52} = \frac{1}{13}$

11. The face cards are K, Q, J. There are $3(4) = 12$ face cards in the deck, so there are $52 - 12 = 40$ non-face cards in the deck. The odds against drawing a face card are $\frac{40}{12} = \frac{10}{3}$.

12. There are 4 6's in the deck. Therefore the odds in favor of drawing a 6 are $\frac{4}{48} = \frac{1}{12}$.

13. $P(\text{diamond}) = \frac{13}{52} = \frac{1}{4}$

14. $P(\text{nine of clubs}) = \frac{1}{52}$

15. $P(\text{king or 8-hearts}) = \frac{4}{52} + \frac{1}{52} = \frac{5}{52}$

16. There are 13 spades, so there are 39 non-spades. The odds against drawing a spade are $\frac{39}{13} = \frac{3}{1}$.

17. There are 26 red and 26 black cards. The odds against drawing a red card are the same as the odds for drawing a red card, $\frac{26}{26} = 1$.

18. $P(\text{drawing a card}) = 100\%$

19. Sixty percent is fairly strong likelihood because it is larger than a chance happening of 50%.

20. [This answer is one of many.] The probability of a hurricane in my area tomorrow is nearly 0%. First, I live about 1,000 miles inland. Second, it is not hurricane season.

21. {HH, HT, TH, TT}

22. $P(\text{one H and one T}) = \frac{2}{4} = \frac{1}{2}$

23. $P(\text{HH}) = \frac{1}{4}$

24. $P(\text{each coin landing on H or T}) = 100\%$

25.

Flip	1	2	3	4	5	6	7	8	9	10	11	12	13	14	15	16	17	18	19	20
Outcome	TT	TH	TH	HT	TT	TT	HH	HH	TH	TT	TH	HH	HT	TH	HH	HH	HH	TT	HH	HH

The experimental probability for flipping two heads is $P(\text{HH}) = \frac{8}{20} = \frac{2}{5}$. The theoretical probability for flipping two heads is $P(\text{HH}) = \frac{1}{4}$.

26. $-2 \leq w < 6$

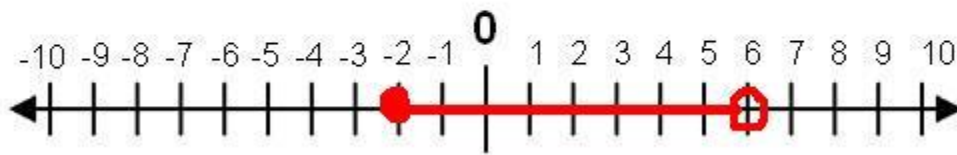

27. $|n - 3| > 12$

$$n - 3 > 12$$

OR

$$n - 3 < -12$$

$$n > 15$$

OR

$$n < -9$$

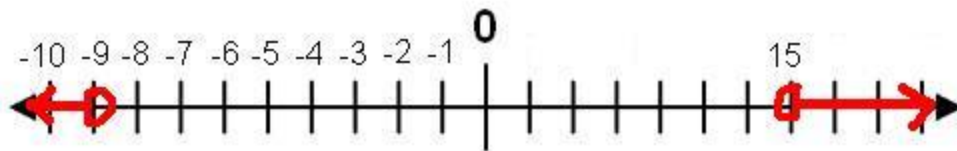

28. $|n - 3| > 12$

$n = 4.175$ is not a solution because it does not fall within the shaded areas of the solutions.

29.

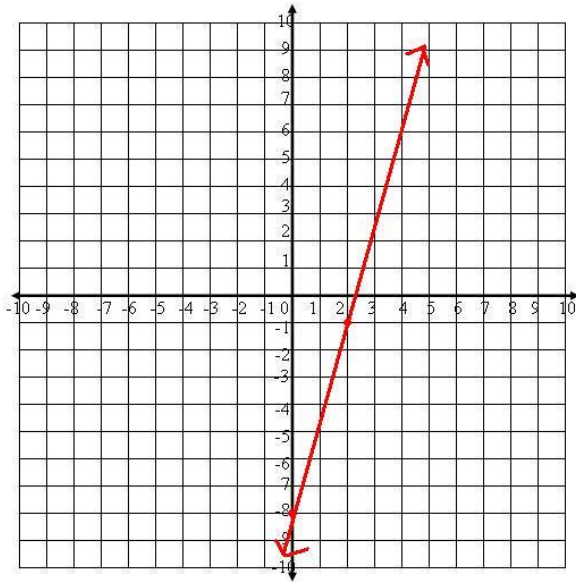

30. The values reduce by 5 each time. Therefore, the pattern is -5 .

$$31. (-3) \left(\frac{(29)(2)(-8)}{-10} \right) = (-3) \left(\frac{-464}{-10} \right) = (-3) \left(\frac{232}{5} \right) = -\frac{696}{5} \text{ OR } -139\frac{1}{5}$$

6.9 Chapter Review

1. algebraic inequality – a mathematical sentence connecting an expression to a value, variable, or another expression with an inequality sign (page 218).
2. interval notation – this notation uses brackets to denote the range of values in an inequality (page 219).
3. intersection of sets – What the sets have in common (page 231).
4. union of sets – Combining both sets into one large set (page 231).
5. absolute value – the distance from zero on a number line (page 237).
6. compound inequality – inequalities that relate to the same topic; uses words “and” and “or” (page 231).
7. boundary line – the line that separates the shaded half-plane from the unshaded half-plane in a linear inequality
8. half-plane – the space on either side of a graphed line (boundary line)
9. solution set – the values that make a given inequality true
10. probability – the likelihood of a given event occurring
11. theoretical probability – what one thinks will happen before an event occurs
12. experimental probability – what actually happens during an event

13. $|16 - 104| = |-88| = 88$

14. Let x = the number of eggs Shanna needs. Then $x < 12$.

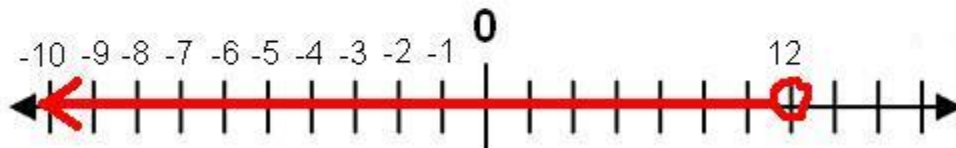

15. Let x = the number of eggs Shanna needs. Then $x \leq 8$.

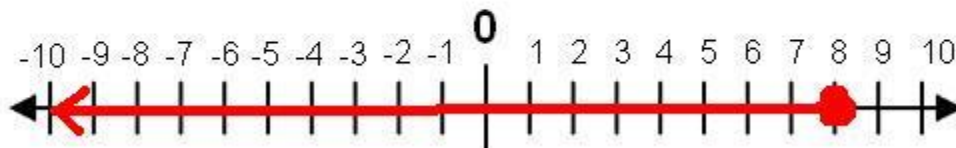

$$16. y + 7 \geq 36$$
$$y \geq 29$$

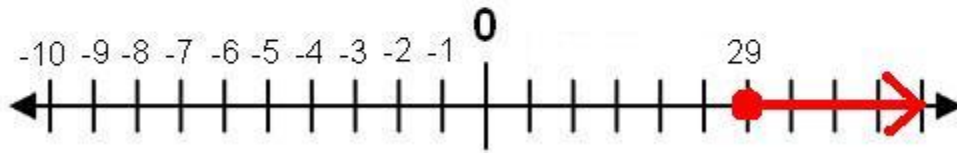

$$17. 16x < 1$$
$$x < \frac{1}{16}$$

$$18. y - 64 < -64$$
$$y < 0$$

$$19. 5 > \frac{t}{3}$$
$$15 > t$$

$$20. 0 < 6 - k$$
$$-6 < -k$$
$$6 > k$$

$$21. -\frac{3}{4}g \leq 12$$
$$g \geq 12\left(-\frac{4}{3}\right)$$
$$g \geq -16$$

$$22. 10 \geq \frac{q}{-3}$$
$$-30 \leq q$$

$$23. -14 + m > 7$$
$$m > 21$$

$$24. 4 \geq d + 11$$
$$-7 \geq d$$

$$25. t - 9 \leq -100$$
$$t \leq -91$$

$$26. \frac{v}{7} < -2$$
$$v < -14$$

$$27. 4x > -4 \quad \text{AND} \quad \frac{x}{5} < 0$$
$$x > -1 \quad \text{AND} \quad x < 0$$

$$28. n - 1 < -5 \quad \text{OR} \quad \frac{n}{3} \geq -1$$
$$n < -4 \quad \text{OR} \quad n > -3$$

$$29. \frac{n}{2} > -2 \quad \text{AND} \quad -5n > -20$$
$$n > -4 \quad \text{AND} \quad n < 4$$

$$30. -35 + 3x > 5(x - 5)$$
$$-35 + 3x > 5x - 25$$
$$-35 > 2x - 25$$
$$-10 > 2x$$
$$-5 > x$$

$$31. x + 6 - 11x \geq -2(3 + 5x) + 12(x + 12)$$
$$x + 6 - 11x \geq -6 - 10x + 12x + 144$$
$$-10x \geq 2x + 138$$
$$-12x \geq 138$$
$$x \leq -11.5$$

$$32. -64 < 8(6 + 2k)$$
$$-64 < 48 + 16k$$
$$112 < 16k$$
$$7 < k$$

$$33. 0 > 2(x + 4)$$
$$0 > 2x + 8$$
$$-8 > 2x$$
$$-4 > x$$

$$34. -4(2n - 7) \leq 37 - 5n$$
$$-8n + 28 \leq 37 - 5n$$
$$28 \leq 37 + 2n$$
$$-9 \leq 2n$$
$$-4.5 \leq n$$

35. $6b + 14 \leq -8(-5b - 6)$

$$6b + 14 \leq 40b + 48$$

$$14 \leq 32b + 48$$

$$34 \leq 32b$$

$$1\frac{1}{16} \leq b$$

36. The inequality $6b + 14 \leq -8(-5b - 6)$ has infinitely many solutions.

37. $6x + 11 < 3(2x - 5)$

$$6x + 11 < 6x - 15$$

$$11 < -15$$

This inequality has no solution.

38. Let m = the number of miles.

$$0.15m + 25 \geq 108$$

$$0.15m \geq 83$$

$$m \geq 553.3 \text{ miles}$$

39. The smallest part will be $15 - 0.015 = 14.985$ cm. The largest part will be $15 + 0.015 = 15.015$ cm.

40. Let s = the number of pounds of strawberries, and b = the number of pounds of blueberries.

$$1.67s + 1.89b \leq 12.00$$

$$1.89b \leq -1.67s + 12.00$$

$$b \leq -0.884s + 6.349$$

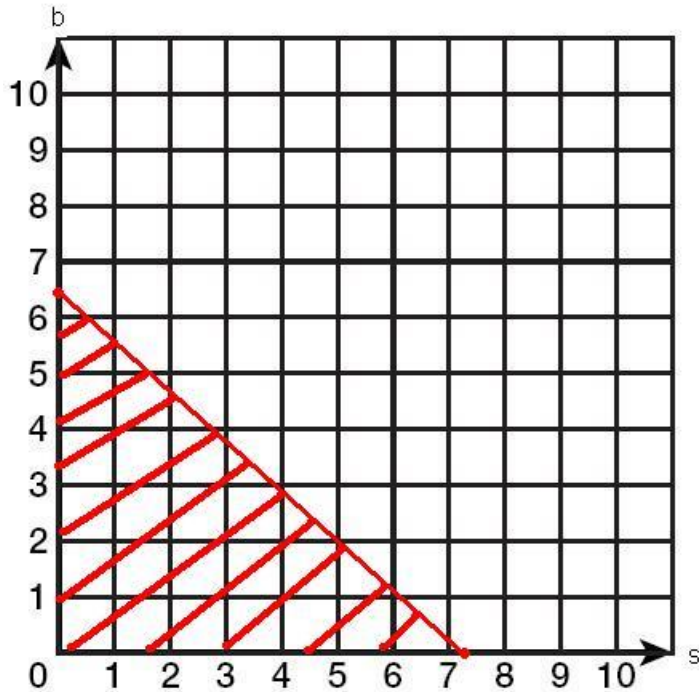

41. $24 = |8z|$
 $8z = 24$ OR $8z = -24$
 $z = 3$ OR $z = -3$

42. $\left| \frac{u}{4} \right| = -1.5$

There is no solution to this equation because an absolute value cannot be equal to a negative value.

43. $1 = |4r - 7| - 2$
 $3 = |4r - 7|$
 $4r - 7 = 3$ OR $4r - 7 = -3$
 $4r = 10$ OR $4r = 4$
 $r = \frac{5}{2}$ OR $r = 1$

44. $|-9 + x| = 7$
 $-9 + x = 7$ OR $-9 + x = -7$
 $x = 16$ OR $x = 2$

45. $y = |x| - 2$

x	y
-2	0
-1	-1
0	-2
1	-1
2	0

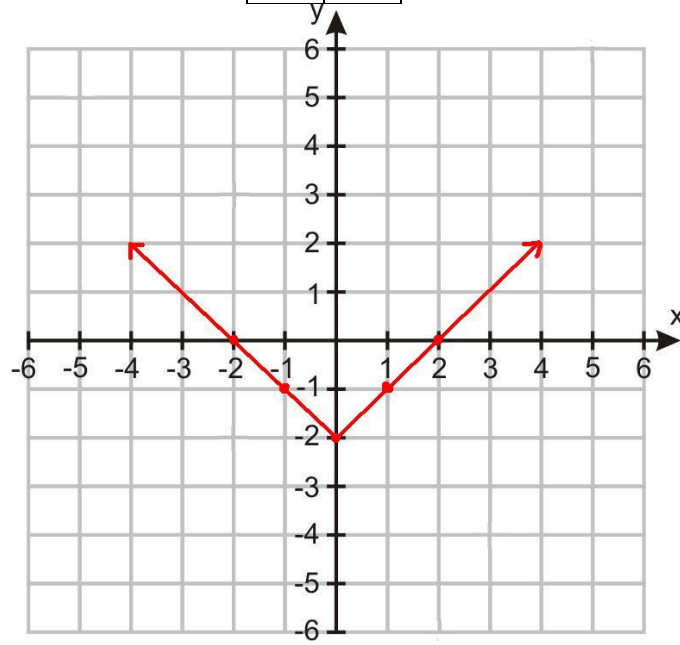

46. $y = -|x + 4|$

x	y
-6	-2
-5	-1
-4	0
-3	-1
-2	-2

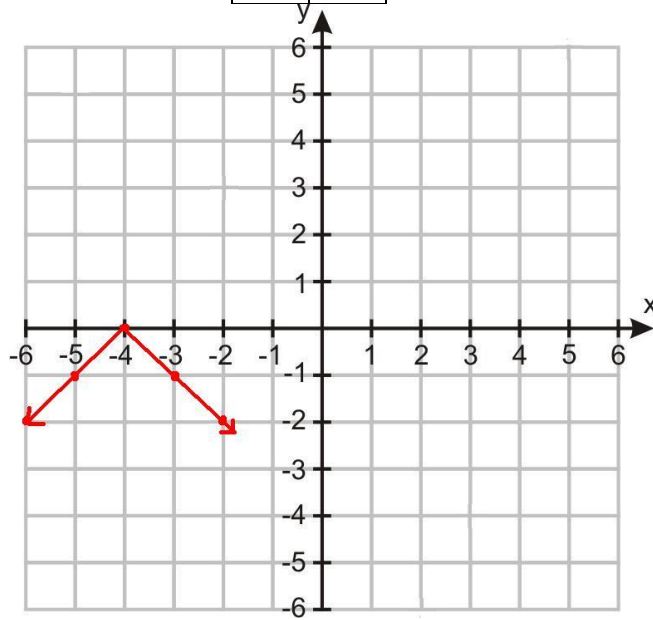

$$47. y = |x + 1| + 1$$

x	y
-3	3
-2	2
-1	1
0	2
1	3

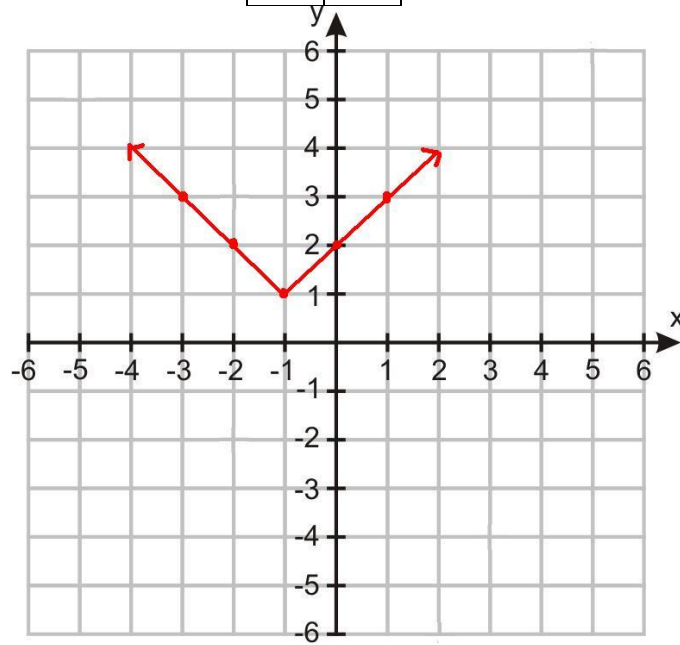

$$48. y \geq -x + 3$$

x	y
-2	5
-1	4
0	3
1	2
2	1

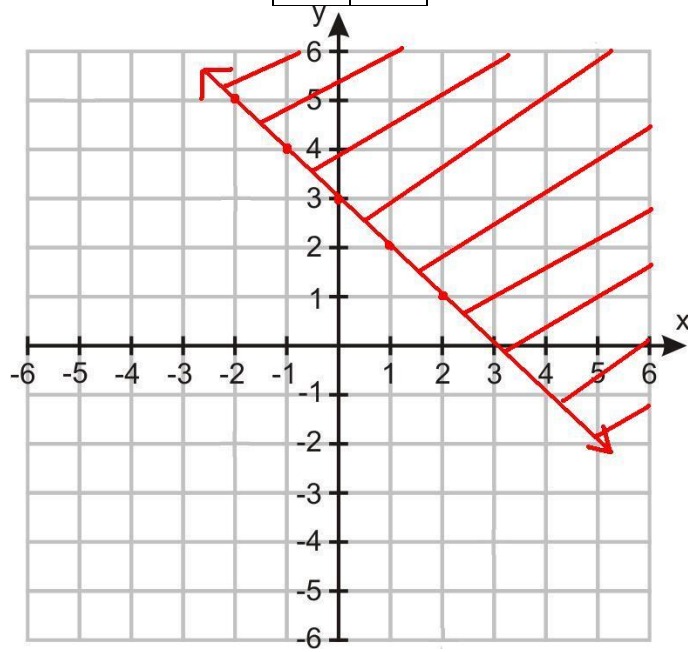

49. $y < -3x + 7$

x	y
-1	10
0	7
1	4

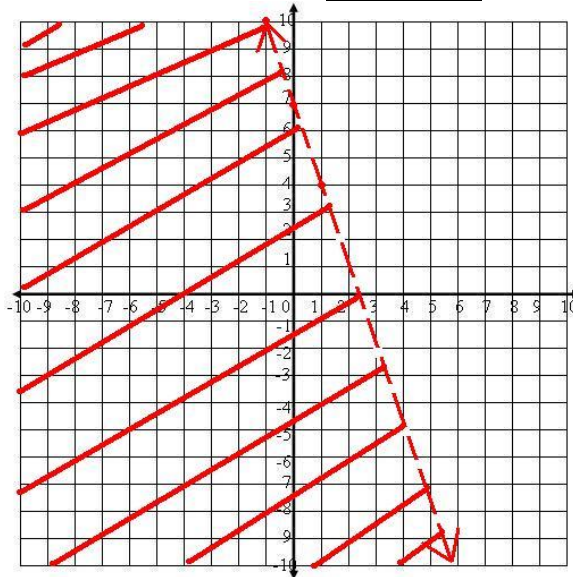

50. $3x + y \leq -4$
 $y \leq -3x - 4$

x	y
-2	2
0	-4
2	-10

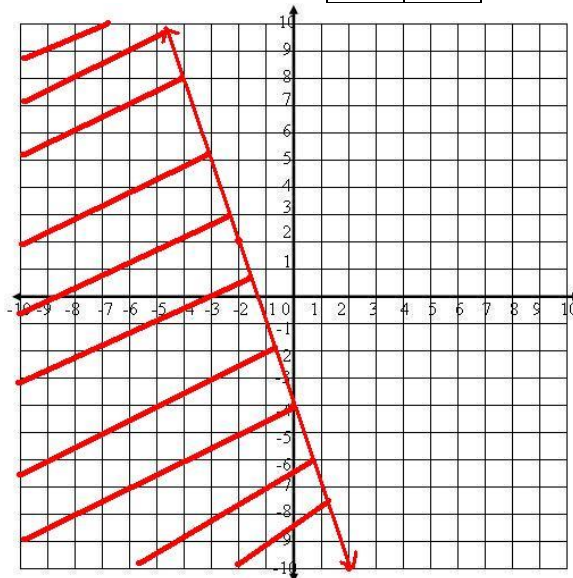

$$51. y > -\frac{1}{4}x + 6$$

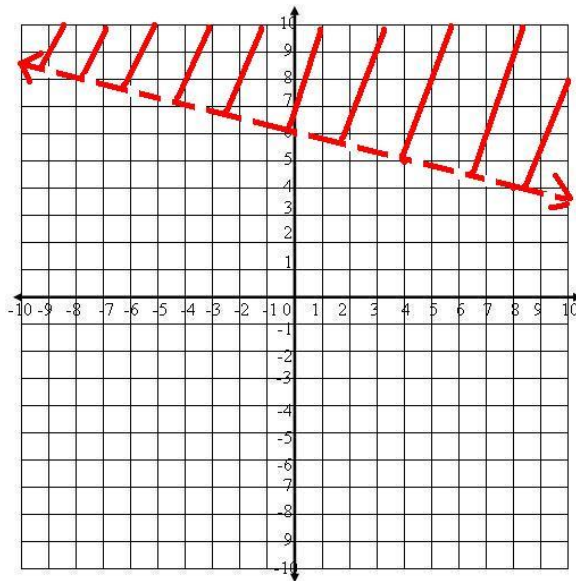

$$52. 8x - 3y \leq -12$$

$$-3y \leq -8x - 12$$

$$y \geq 8x + 12$$

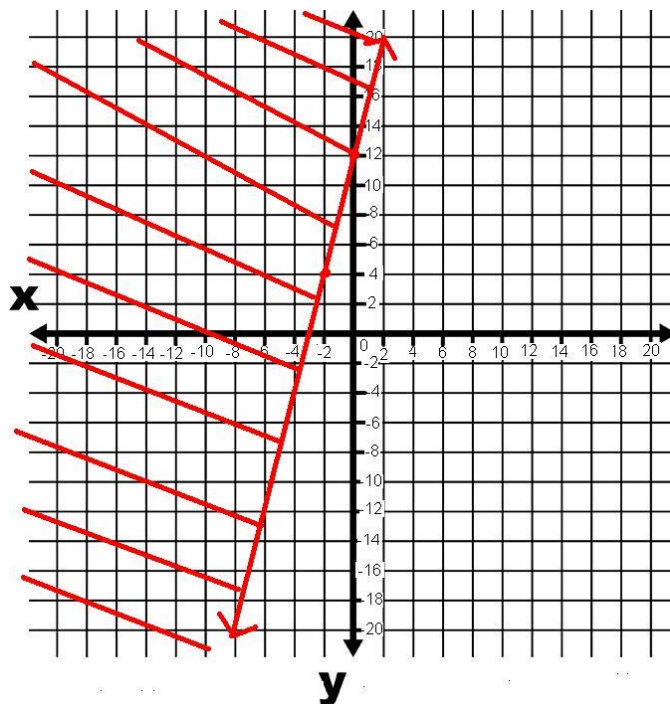

53. $x < -3$

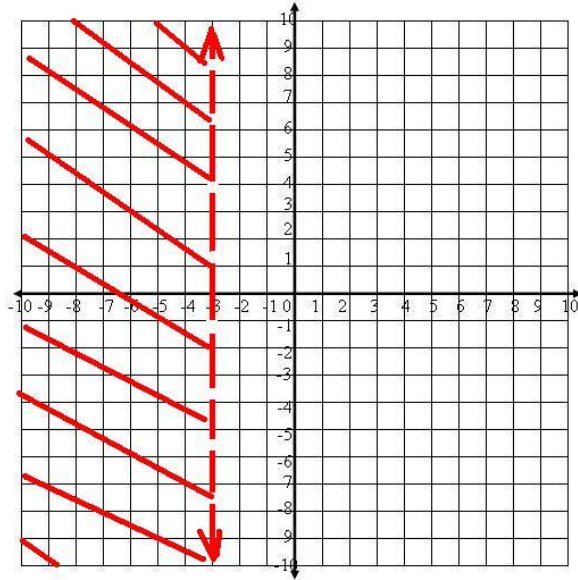

54. $y > -5$

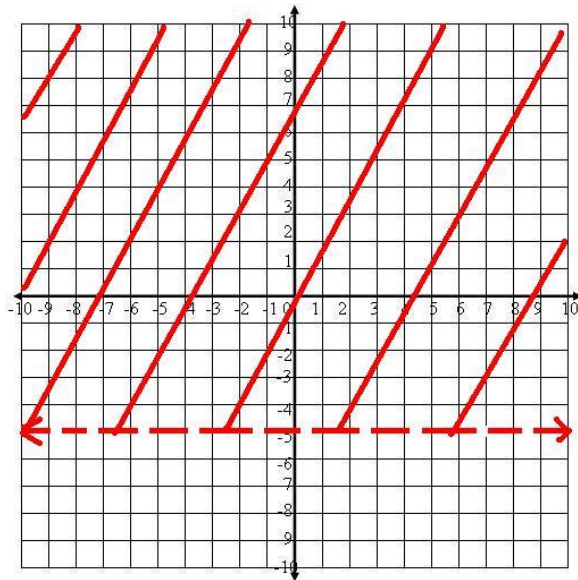

55. $-2 < x \leq 5$

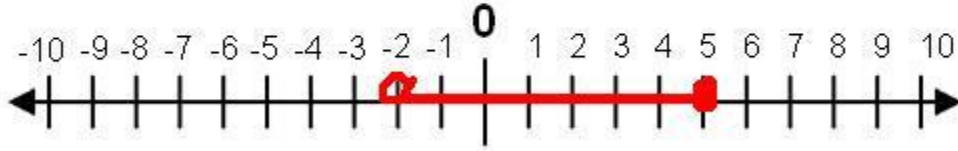

56. $0 \leq y \leq 3$

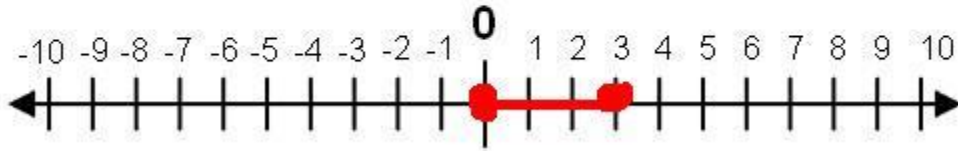

57. $|x| > 4$
 $x > 4$ OR $x < -4$

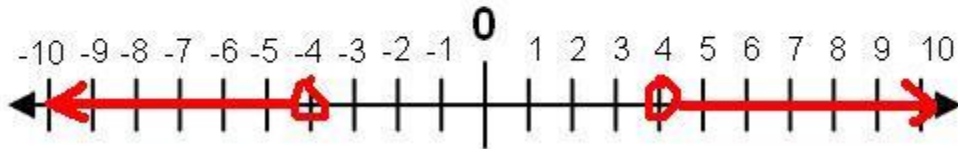

58. $|y| \leq -2$
 $y \leq -2$ OR $y \geq 2$

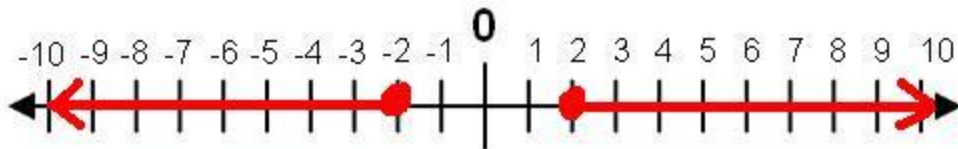

59. Sample space = $\{1, 2, 3, 4, 5, 6, 7, 8\}$

60. $\frac{1}{8}$

61. There are 4 even numbers, so the $P(\text{even}) = \frac{1}{2}$.

62. The multiples of 2 are 2, 4, 6, and 8. Therefore the odds for landing on a multiple of 2 are 4:4 or 1:1.

63. The prime numbers are 3, 5, and 7. Therefore the odds against landing on a prime number are 5:3.

64.

Spin	1	2	3	4	5	6	7	8	9	10	11	12	13	14	15
Outcome	1	2	3	3	1	7	3	3	3	6	1	8	5	2	8

$$P(3) = \frac{5}{15} = \frac{1}{3}$$

$$65. P(x > 5) = \frac{4}{15}$$

$$66. P(1 \leq x \leq 8) = 1 = 100\%$$

$$67. P(\text{even}) = \frac{1}{2}$$

6.10 Chapter 6 Test

1. a) $P(\text{red } 4) = \frac{2}{52} = \frac{1}{26}$

b) $P(\text{purple Ace}) = 0$

c) $P(\text{number card}) = \frac{36}{52} = \frac{9}{13}$

2.

$$-7 \leq y + 7 < 5$$

$$-7 \leq y + 7$$

$$-14 \leq y$$

AND

$$y + 7 < 5$$

AND

$$y < -2$$

3.

The distance between -1.5 and 9 is $|-1.5 - 9| = |-10.5| = 10.5$.

4.

$$23 = |8 - 7r| + 3$$

$$20 = |8 - 7r|$$

$$8 - 7r = 20$$

OR

$$8 - 7r = -20$$

$$-7r = 12$$

OR

$$-7r = -28$$

$$r = -\frac{12}{7}$$

OR

$$r = 4$$

5.

$$|-7c| \geq 49$$

$$-7c \geq 49$$

$$c \leq -7$$

OR

$$-7c \leq -49$$

OR

$$c \geq 7$$

6.

$$x - 2y \leq 10$$

$$-2y \leq -x + 10$$

$$y \geq \frac{1}{2}x - 5$$

7.

$$y > -\frac{3}{5}x + 4$$

8. $y = -|x - 3|$

x	y
1	-2
2	-1
3	0
4	-1
5	-2

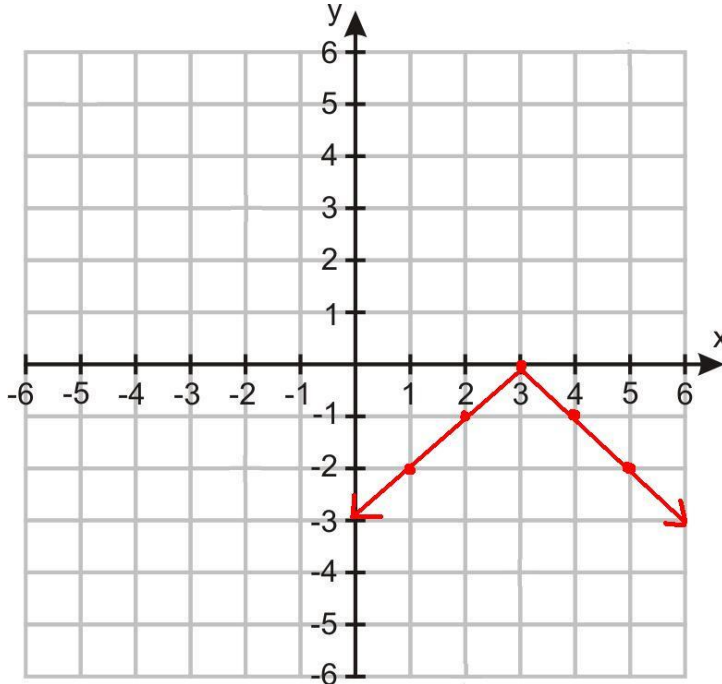

9.

a. Sample space = {red, red, blue, blue, blue, black, black, black, black}

b. $P(\text{blue}) = \frac{3}{9} = \frac{1}{3}$

c. Odds against drawing a black sock = 5:4

d. Odds for drawing a red sock = 2:7

10.

$$2(6 + 7r) > -12 + 8r$$

$$12 + 14r > -12 + 8r$$

$$22r > -24$$

$$r > -\frac{24}{22} \text{ OR } -1\frac{1}{11}$$

11.

$$-56 \leq 8 + 8(7x + 6)$$

$$-56 \leq 8 + 56x + 48$$

$$-56 \leq 56x + 56$$

$$-112 \leq 56x$$

$$-2 \leq x$$

Basic Algebra Flexbook Solution Key
Chapter 7
Systems of Equations and Inequalities; Counting Methods

Lesson 7.1
Linear Systems by Graphing

1. A **system** is a set of equations or inequalities with the same variables.
OR
- A **system** is a set of algebraic sentences joined by the word “and”.
2. The solution to a system is the set of ordered pairs that are in common to each algebraic sentence.
3. To solve a system by graphing:
 - 1) graph each equation in the system on the same set of axes
 - 2) find the point(s) at which the graphs intersect
 - 3) the point(s) of intersection are the solution to the system
4. One problem with using a graph to solve a system is that it requires very careful graphing, and even when that is done, it is likely that the graph can only give you an approximate value of the intersection (solution). If the intersection values are both integers, then it works, but in most cases another method would be necessary to find the exact solution.
5. The two main ways to write the solution to a system of equations are as an ordered pair (x, y) or as equivalent values: $x=?$ and $y=?$
6. If the solution to a system is $(4, -6)$ then the graphs of each equation will intersect at $(4, -6)$. Each graph will cross through the point $(4, -6)$.
7. The “**Intersection**” command is located in the “**Calculate**” menu of your calculator. When in the graphing mode, if you press “2nd” then “**Trace**” you will see a list that includes “**Intersection**”. If you select this command the calculator will show you at what x and y values the two graphs you have entered cross or intersect.
8. Peter will be further from the starting line at 19.99 seconds and Nadia will be further from the starting line at 20.02 seconds. Peter has a 20 second head start and Nadia catches up with him at 20 seconds. At any time before 20 seconds, Peter will be ahead. At any time after 20 seconds Nadia will be ahead.

9. To find which ordered pair is the solution, we must plug each one into both equations.

$$(1,4) \begin{cases} y = 3x - 2 & 4 = 3(1) - 2 & 4 = 3 - 2 & 4 \neq 1 \\ y = -x & 4 = -(1) & 4 \neq -1 \end{cases} \text{ Does not work}$$

$$(2,9) \begin{cases} y = 3x - 2 & 9 = 3(2) - 2 & 9 = 6 - 2 & 9 \neq 4 \\ y = -x & 9 = -(2) & 9 \neq -2 \end{cases} \text{ Does not work}$$

$$\left(\frac{1}{2}, -\frac{1}{2}\right) \begin{cases} y = 3x - 2 & -\frac{1}{2} = 3\left(\frac{1}{2}\right) - 2 & -\frac{1}{2} = \frac{3}{2} - 2 & -\frac{1}{2} = -\frac{1}{2} \\ y = -x & -\frac{1}{2} = -\left(\frac{1}{2}\right) & -\frac{1}{2} = -\frac{1}{2} \end{cases}$$

This is the solution.

10. To find which ordered pair is the solution, we must plug each one into both equations.

$$(8,13) \begin{cases} y = 2x - 3 & 13 = 2(8) - 3 & 13 = 16 - 3 & 13 = 13 \\ y = x + 5 & 13 = 8 + 5 & 13 = 13 \end{cases} \text{ This is the solution.}$$

$$(-7, 6) \begin{cases} y = 2x - 3 & 6 = 2(-7) - 3 & 6 = (-14) - 3 & 6 \neq -17 \\ y = x + 5 & 6 = -7 + 5 & 6 \neq -2 \end{cases} \text{ Does not work}$$

$$(0, 4) \begin{cases} y = 2x - 3 & 4 = 2(0) - 3 & 4 = 0 - 3 & 4 \neq -3 \\ y = x + 5 & 4 = 0 + 5 & 4 \neq 9 \end{cases} \text{ Does not work}$$

11. To find which ordered pair is the solution, we must plug each one into both equations.

$$(-9, 1) \begin{cases} 2x + y = 8 & 2(-9) + 1 = 8 & -18 + 1 = 8 & -17 \neq 8 \\ 5x + 2y = 10 & 5(-9) + 2(1) = 8 & -45 + 2 = 8 & -43 \neq 8 \end{cases} \text{Does not work}$$

$$(-6, 20) \begin{cases} 2x + y = 8 & 2(-6) + 20 = 8 & -12 + 20 = 8 & 8 = 8 \\ 5x + 2y = 10 & 5(-6) + 2(20) = 10 & (-30) + (40) = 10 & 10 = 10 \end{cases}$$

This is the solution.

$$(14, 2) \begin{cases} 2x + y = 8 & 2(14) + 2 = 8 & 28 + 2 = 8 & 30 \neq 8 \\ 5x + 2y = 10 & 5(14) + 2(2) = 10 & 70 + 4 = 10 & 74 \neq 10 \end{cases} \text{Does not work}$$

12. To find which ordered pair is the solution, we must plug each one into both equations.

$$\left(3, -\frac{3}{2}\right) \begin{cases} 3x + 2y = 6 & 3(3) + 2\left(-\frac{3}{2}\right) = 6 & 9 + \left(-\frac{6}{2}\right) = 6 & 9 + (-3) = 6 & 6 = 6 \\ y = \frac{x}{2} - 3 & -\frac{3}{2} = \frac{3}{2} - 3 & -\frac{3}{2} = \left(-\frac{3}{2}\right) - \left(\frac{6}{2}\right) & -\frac{3}{2} = -\frac{3}{2} \end{cases}$$

This is the solution.

$$(-4, 3) \begin{cases} 3x + 2y = 6 & 3(-4) + 2(3) = 6 & -12 + 6 = 6 & -6 \neq 6 \\ y = \frac{x}{2} - 3 & 3 = \frac{-4}{2} - 3 & 3 = -2 - 3 & 3 \neq -5 \end{cases} \text{Does not work}$$

$$\left(\frac{1}{2}, 4\right) \begin{cases} 3x + 2y = 6 & 3\left(\frac{1}{2}\right) + 2(4) = 6 & \frac{3}{2} + 8 = 6 & \frac{3}{2} + \frac{16}{2} = 6 & \frac{19}{2} = 9\frac{1}{2} \neq 6 \\ y = \frac{x}{2} - 3 & 4 = \frac{\frac{1}{2}}{2} - 3 & 4 = \frac{1}{4} - 3 & 4 \neq -2\frac{3}{4} \end{cases}$$

Does not work

13. $y = x + 3$
 $y = -x + 3$

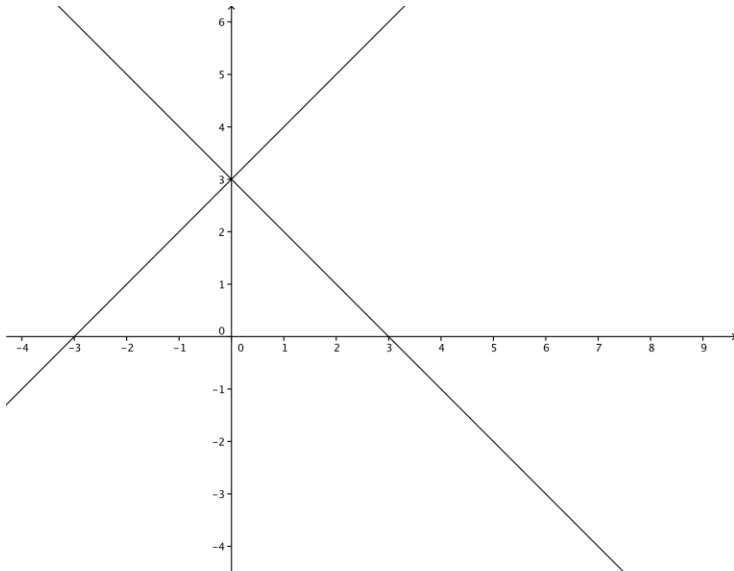

(0,3) is the solution for this set of equations, because that is where the two graphs intersect.

14. $y = 3x - 6$
 $y = -x + 6$

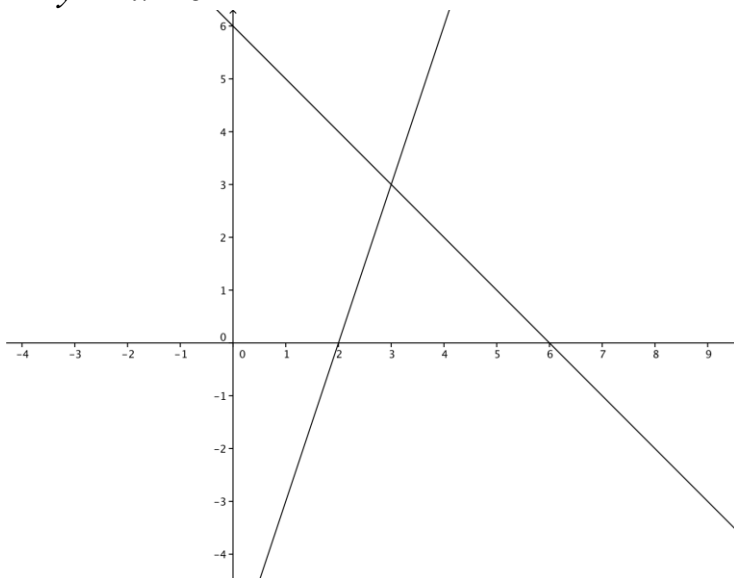

(3,3) is the solution for this set of equations, because that is where the two graphs intersect.

15. $2x = 4$ is the same as $x = 2$
 $y = -3$ $y = -3$

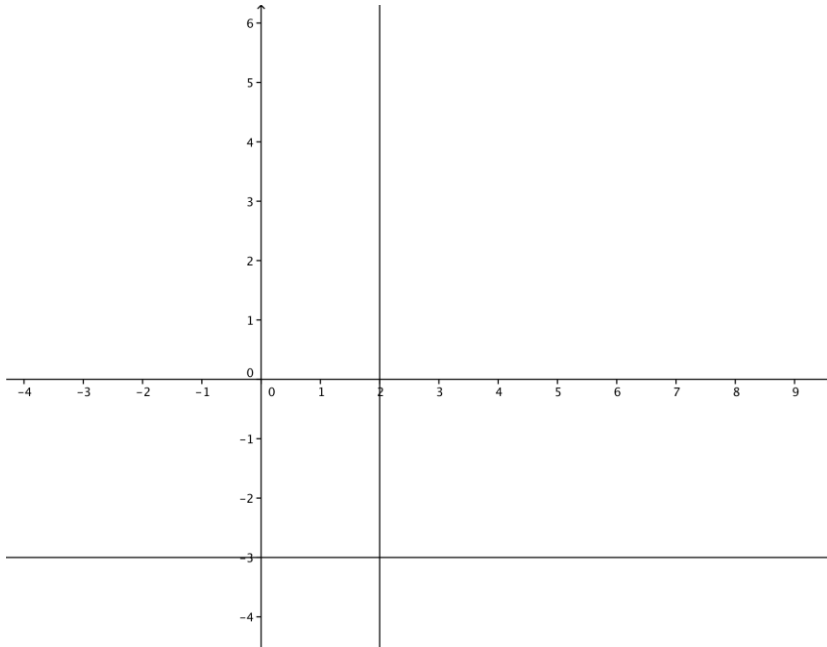

$(2, -3)$ is the solution for this set of equations, because that is where the two graphs intersect.

16. $y = -x + 5$ is the same as $y = -x + 5$
 $-x + y = 1$ $y = x + 1$

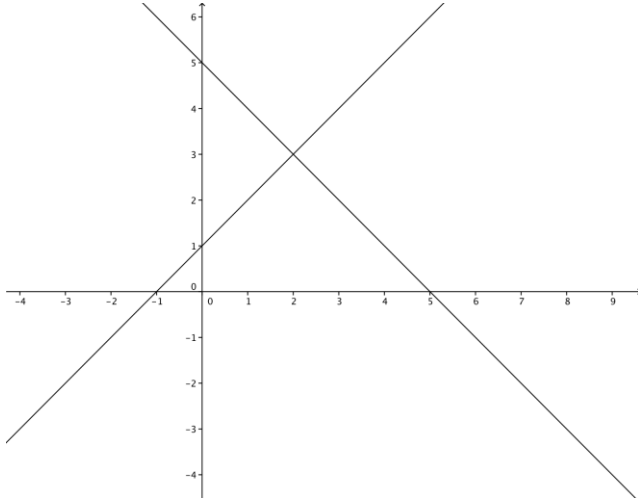

(2,3) is the solution for this set of equations, because that is where the two graphs intersect.

17. $x + 2y = 8$
 $5x + 2y = 0$

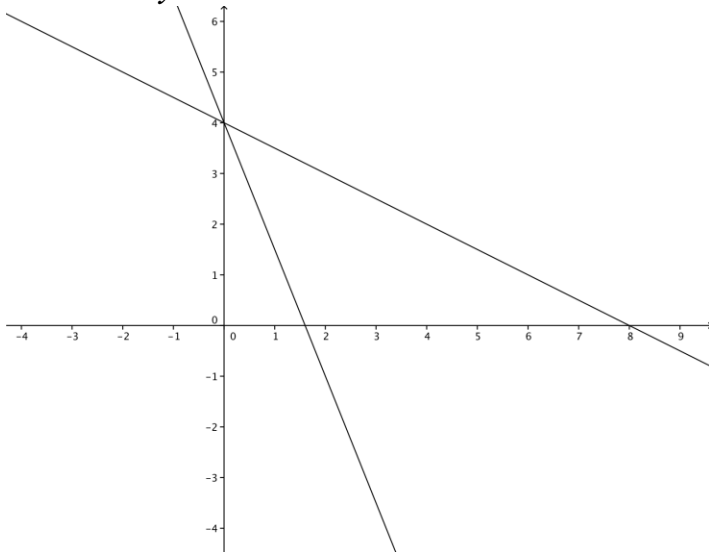

(0, 4) is the solution for this set of equations, because that is where the two graphs intersect.

18. $3x + 2y = 12$
 $4x - y = 5$

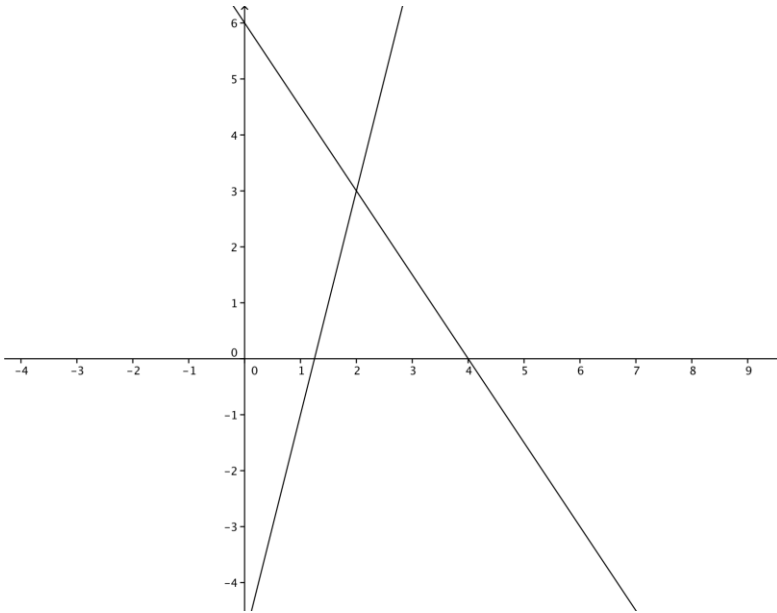

(2,3) is the solution for this set of equations, because that is where the two graphs intersect.

19. $5x + 2y = -4$
 $x - y = 2$

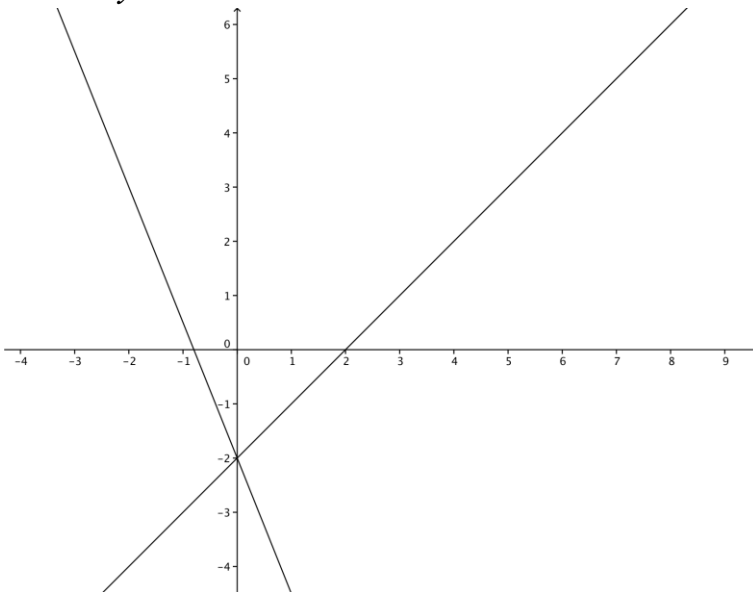

(0, -2) is the solution for this set of equations, because that is where the two graphs intersect.

20. $2x = 4 = 3y$
 $x - 2y + 4 = 0$

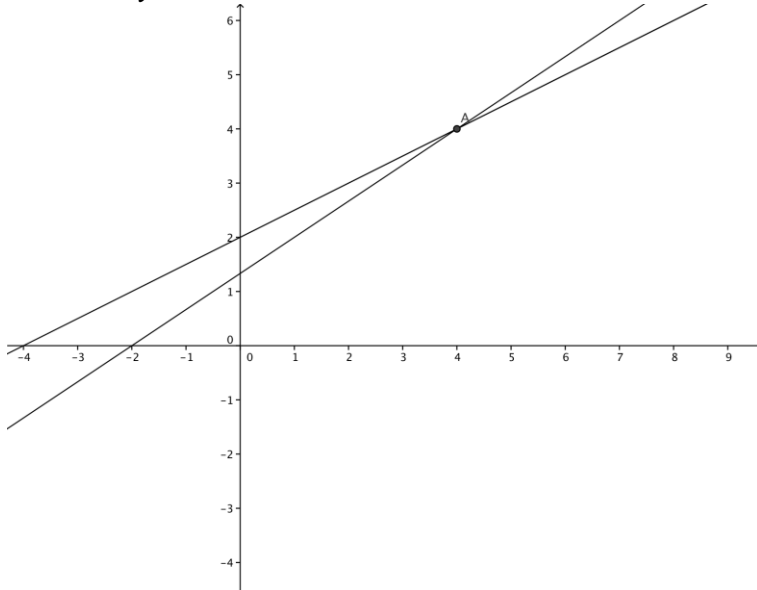

(4,4) is the solution for this set of equations, because that is where the two graphs intersect. (This is an approximate based on the graphs.)

21. $y = \frac{x}{2} - 3$

$2x - 5y = 5$

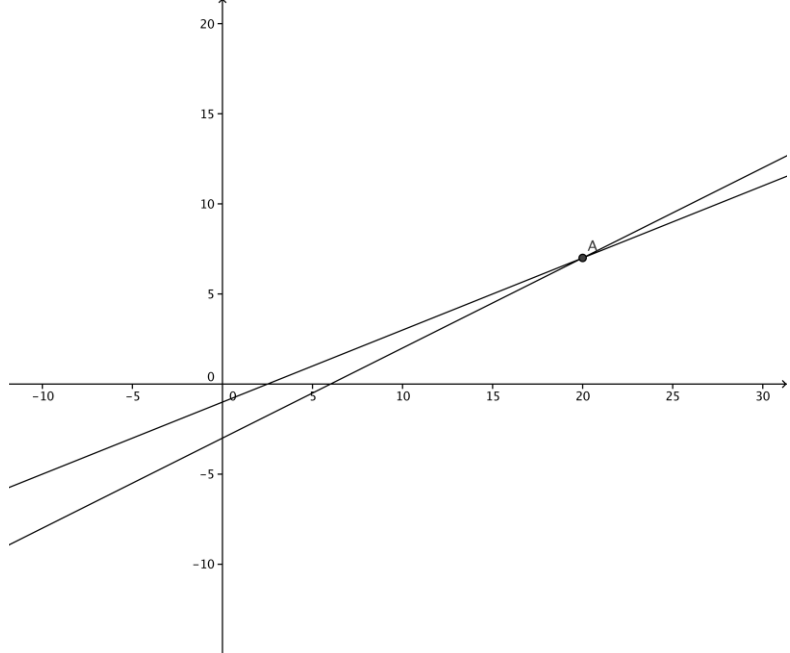

(20,7) is the solution for this set of equations, because that is where the two graphs intersect. (This is an approximate based on the graphs.)

22. $y = 4$
 $x = 8 - 3y$

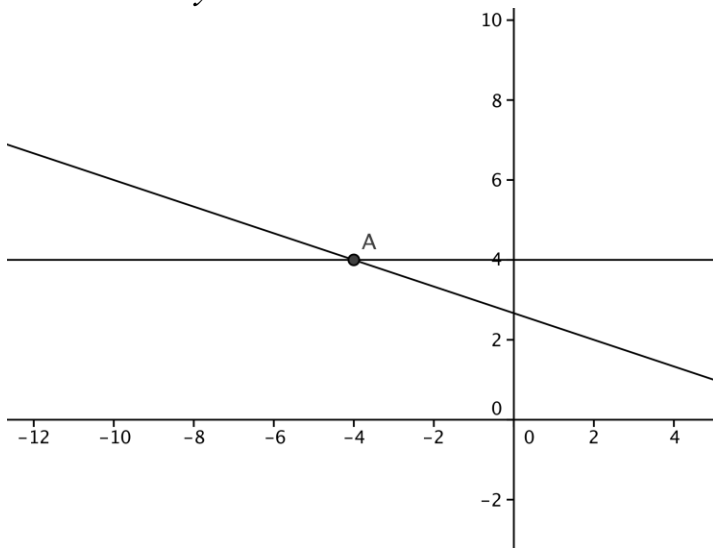

$(-4, 4)$ is the solution for this set of equations, because that is where the two graphs intersect. (This is an approximate based on the graphs.)

23.

Let's make X the total cost for each car.

Let's make Y the number of years.

Using the information in the problem and these two variables we can create two equations for what each car would cost over time.

Mary's car: $x = 1200 + 2000y$

For Mary's car we add the cost of her current repair to the amount that gas will cost her multiplied by each year that goes by.

New car: $x = 4500 + 1500y$

For the new car we add the purchase cost to the amount that gas will cost her multiplied by each year that goes by.

We are looking to find at what year (y) the total costs (x) will be the same.

We can do this by graphing each equation and finding the point of intersection.

(Note: I used $x = 12 + 20y$
 $x = 45 + 15y$ which are equivalent to the original equations,

because the numbers were easier to work with on the graph.)

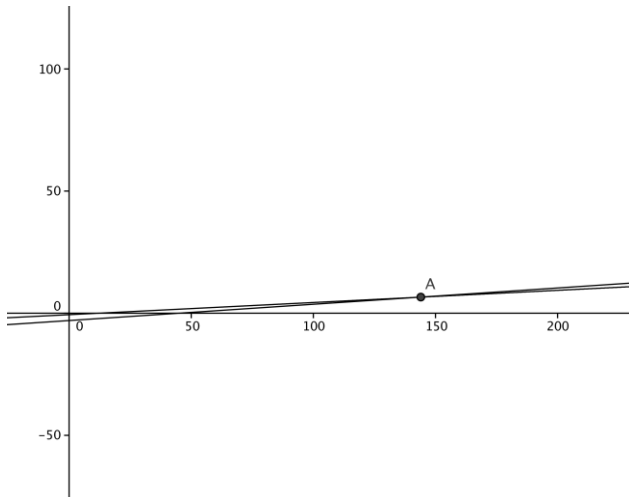

The graph shows that the two equations intersect at $(14400, 6.6)$. This means that when the total cost for each car is $x=14400$, the number of years that will have passed is $y=6.6$. The solution is 6.6 years.

24.

Let's make X the total cost for each phone and plan.

Let's make Y the number of months.

Using the information in the problem and these two variables we can create two equations for what each cell phone plan would cost over time.

Plan #1: $x=120 + 30y$

For plan #1 we add the cost of the phone to the amount that the plan will cost him multiplied by each month that goes by.

Plan #2: $x= 40 + 45y$

For plan #2 we add the cost of the phone to the amount that the plan will cost him multiplied by each month that goes by.

We are looking to find at what month (y) the total costs (x) will be the same.

We can do this by graphing each equation and finding the point of intersection.

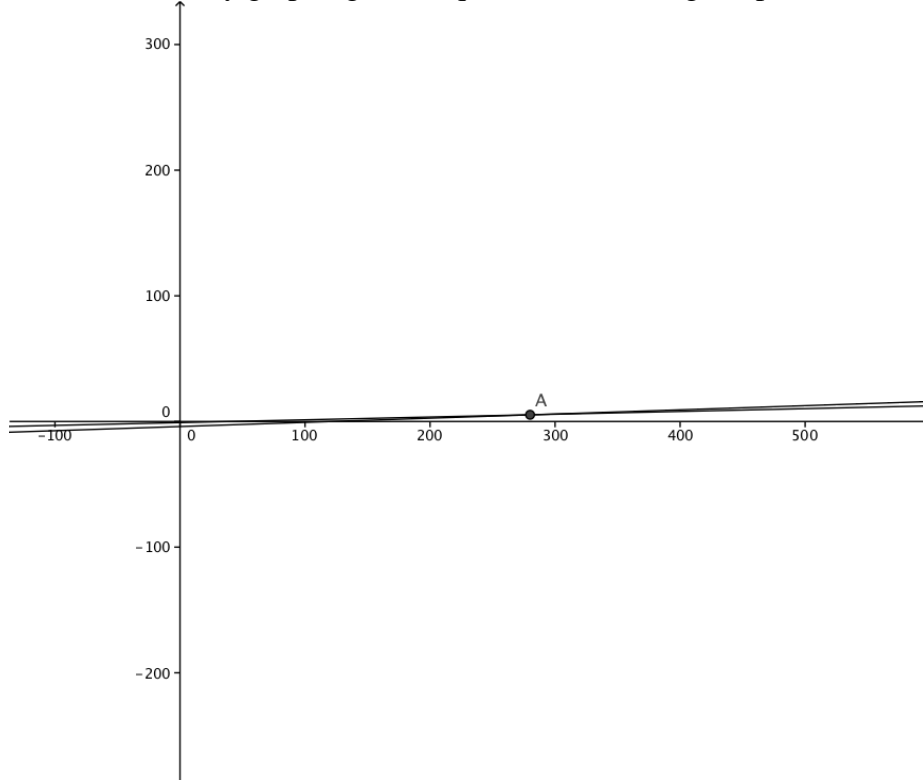

The graph shows that the two equations intersect at $(280, 5.33)$. This means that when the total cost for each plan is $x=280$, the number of months that will have passed is $y=5.33$. The solution is 5.33 or 6 months.

25.

Let's make y the total distance run.

Let's make x the number of seconds.

Using the information in the problem and these two variables we can create two equations for how far each animal would go.

Tortoise: $y = 0.5x + 20$

For the tortoise we add the length of his lead to the rate at which he runs multiplied by each second that goes by.

Hare: $y = 5.5x$

For the Hare we take the rate at which he runs multiplied by each second that goes by.

We are looking to find at what second (x) the total distances (y) will be the same.

We can do this by graphing each equation and finding the point of intersection.

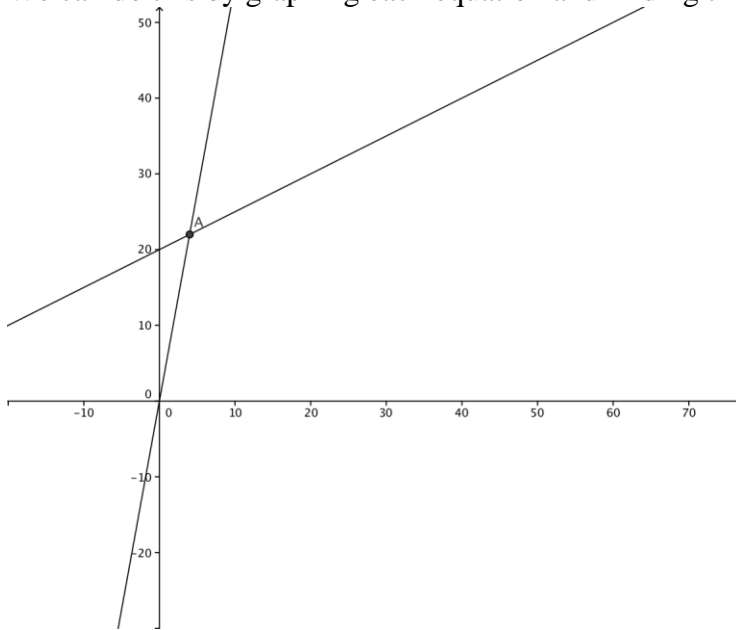

The graph shows that the two equations intersect at $(4, 22)$. This means that when the total distance for each animal is $y=22$, the number of seconds that will have passed is $x=4$. The solution is 4 seconds.

26. Treat the inequality as if it were a regular equation and solve for h:

$$25 = 2h + 5$$

$$20 = 2h \quad \text{Now we know this is actually an inequality so: } 10 \geq h$$

$$10 = h$$

Lets check:

$$h=9 \text{ (9 is less than or equal to 10)}$$

$$25 \geq |2h + 5|$$

$$25 \geq |(2)(9) + 5|$$

$$25 \geq |18 + 5|$$

$$25 \geq |23|$$

The absolute value of 23 is 23 and 25 is greater than or equal to 23, so our answer checks out.

27.

In order to subtract fractions, they must have the same denominator, so we must find the lowest common denominator. In this example the easiest way is to multiply the two denominators. $3 \times 2 = 6$

We must multiply the numerator by the same number we multiply the denominator by, in order to keep the fractions equivalent.

Once the fractions have been changed then we simply subtract the numerator and keep the same denominator.

$$\frac{4}{3} - \frac{1}{2}$$

$$\frac{4 \times 2 = 8}{3 \times 2 = 6} - \frac{1 \times 3 = 3}{2 \times 3 = 6}$$

$$\frac{8}{6} - \frac{3}{6} = \frac{5}{6}$$

28.

(a) There are 8 pieces of paper in the hat and 3 of them are I. Therefore, the probability of drawing an I is 3 out of 8. **3:8**

(b) Once again there are 8 pieces of paper in the hat and this time 2 of them are L. The likelihood of drawing an L is 2 out of 8 or 1 out of 4. **1:4**

29.

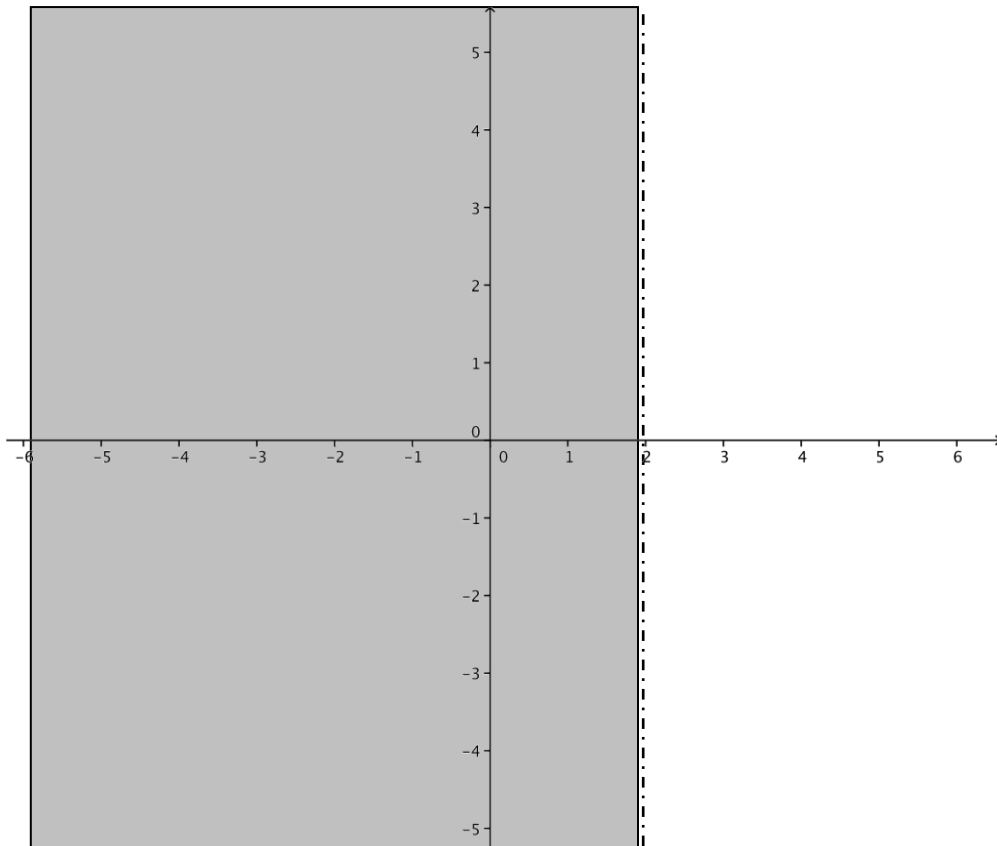
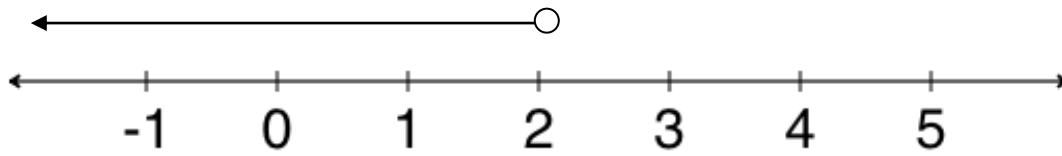

30. Give an example of an ordered pair in quadrant II.

Any answer where the x value is negative and the y value is positive is correct.

31.

(a) First find the slope using the two points around the point you are trying to find.

$$m = \frac{68.2 - 62.9}{1950 - 1940} = \frac{5.3}{10} = 0.53$$

Next find the y-intercept by plugging in one of the two points and the slope.

$$y = mx + b$$

$$68.2 = (.53)(1950) + b$$

$$68.2 = 1033 + b$$

$$b = -964.8$$

The equation becomes:

$$y = 0.53x - 964.8$$

To estimate the life expectancy in 1943, substitute $x=1943$.

$$y = 0.53(1943) - 964.8$$

$$y = 1029.79 - 964.8$$

$$y = 64.99$$

(b) First find the slope using the last two points that you know.

$$m = \frac{76.7 - 75.8}{1998 - 1995} = \frac{0.9}{3} = .3$$

Next find the y-intercept by plugging in one of the two points and the slope.

$$y = mx + b$$

$$76.7 = 0.3(1998) + b$$

$$76.7 = 599.4 + b$$

$$b = -522.7$$

The equation becomes:

$$y = 0.3x - 522.7$$

To estimate the life expectancy in 2000, substitute $x=2000$.

$$y = 0.3(2000) - 522.7$$

$$y = 600 - 522.7$$

$$y = 77.3$$

Lesson 7.2
Solving Systems by Substitution

1)

When you have a system where at least one of the expressions is $y = \text{algebraic expression}$ or $x = \text{algebraic expression}$, the algebraic expression can be substituted for that variable in the other expressions in the system. You then solve for the remaining variable. Once you have a value for that variable you can substitute it into any of the expressions in the system to find the value of the second variable.

2)

Systems are easier to solve using substitution if one of the expressions already has one of the variables isolated on one side of the equation or if it would be easy to isolate one variable on one side of the equation.

$$3) \begin{cases} y = -3 \\ 6x - 2y = 0 \end{cases}$$

$$6x - 2(-3) = 0$$

$$6x + 6 = 0$$

$$6x = -6$$

$$x = -1$$

Check:

$$6x - 2y = 0$$

$$6(-1) - 2(-3) = 0$$

$$-6 + 6 = 0$$

$$0 = 0$$

$$4) \begin{cases} -3 - 3y = 6 \\ y = -3x + 4 \end{cases}$$

$$-3 - 3y = 6$$

$$-3y = 9$$

$$y = -3$$

$$y = -3x + 4$$

$$-3 = -3x + 4$$

$$-7 = -3x$$

$$x = \frac{7}{3}$$

Check:

$$-3 - 3y = 6$$

$$-3 - 3(-3) = 6$$

$$-3 + 9 = 6$$

$$6 = 6$$

$$y = -3x + 4$$

$$-3 = -3\left(\frac{7}{3}\right) + 4$$

$$-3 = -7 + 4$$

$$-3 = -3$$

$$5) \begin{cases} y = 3x + 16 \\ y = x + 8 \end{cases}$$

$$3x + 16 = x + 8$$

$$2x + 16 = 8$$

$$2x = -8$$

$$x = -4$$

$$y = x + 8$$

$$y = -4 + 8$$

$$y = 4$$

Check:

$$y = 3x + 16$$

$$4 = 3(-4) + 16$$

$$4 = -12 + 16$$

$$4 = 4$$

$$y = x + 8$$

$$4 = -4 + 8$$

$$4 = 4$$

$$6) \begin{cases} y = -6x - 3 \\ y = 3 \end{cases}$$

$$y = -6x - 3$$

$$3 = -6x - 3$$

$$6 = -6x$$

$$x = -1$$

Check:

$$y = -6x - 3$$

$$3 = -6(-1) - 3$$

$$3 = 6 - 3$$

$$3 = 3$$

$$7) \begin{cases} y = -2x + 5 \\ y = -1 - 8x \end{cases}$$

$$-2x + 5 = -1 - 8x$$

$$6x + 5 = -1$$

$$6x = -6$$

$$x = -1$$

$$y = -2(-1) + 5$$

$$y = 2 + 5$$

$$y = 7$$

Check:

$$y = -2x + 5$$

$$7 = -2(-1) + 5$$

$$7 = 2 + 5$$

$$7 = 7$$

$$y = -1 - 8x$$

$$7 = -1 - 8(-1)$$

$$7 = -1 + 8$$

$$7 = 7$$

$$8) \begin{cases} y = 6 + x \\ y = -2x - 15 \end{cases}$$

$$6 + x = -2x - 15$$

$$x = -2x - 21$$

$$3x = -21$$

$$x = -7$$

$$y = 6 + x$$

$$y = 6 + (-7)$$

$$y = -1$$

Check:

$$y = 6 + x$$

$$-1 = 6 + (-7)$$

$$-1 = -1$$

$$y = -2x - 15$$

$$-1 = -2(-7) - 15$$

$$-1 = 14 - 15$$

$$-1 = -1$$

$$9) \begin{cases} y = -2 \\ y = 5x - 17 \end{cases}$$

$$y = 5x - 17$$

$$-2 = 5x - 17$$

$$15 = 5x$$

$$x = 3$$

Check:

$$y = 5x - 17$$

$$-2 = 5(3) - 17$$

$$-2 = 15 - 17$$

$$-2 = -2$$

$$10) \begin{cases} x + y = 5 & x + y = 5 & 3x + y = 15 \\ 3x + y = 15 & y = 5 - x & y = 15 - 3x \end{cases}$$

$$5 - x = 15 - 3x$$

$$5 = 15 - 2x$$

$$-10 = -2x$$

$$x = 5$$

$$x + y = 5$$

$$5 + y = 5$$

$$y = 0$$

Check:

$$\begin{array}{ll} x + y = 5 & 3x + y = 15 \\ 5 + 0 = 5 & 3(5) + 0 = 15 \\ 5 = 5 & 15 + 0 = 15 \\ & 15 = 15 \end{array}$$

$$11) \begin{cases} 12y - 3x = -1 \\ x - 4y = 1 \end{cases}$$

$$x - 4y = 1$$

$$x = 4y + 1$$

$$12y - 3x = -1$$

$$12y - 3(4y + 1) = -1$$

$$12y - 12y + 3 = -1$$

$$3 = -1$$

$$12y - 3x = -1$$

$$-3x = -12y - 1$$

$$x = 4y + \frac{1}{3}$$

$$x - 4y = 1$$

$$\left(4y + \frac{1}{3}\right) - 4y = 1$$

$$4y + \frac{1}{3} - 4y = 1$$

$$\frac{1}{3} \neq 1$$

There is no solution set.
The solution is *undefined*.

$$12. \begin{cases} x + 2y = 9 \\ 3x + 5y = 20 \end{cases}$$

$$x + 2y = 9$$

$$x = -2y + 9$$

$$3x + 5y = 20$$

$$3(-2y + 9) + 5y = 20$$

$$-6y + 27 + 5y = 20$$

$$-y + 27 = 20$$

$$-y = -7$$

$$y = 7$$

$$x + 2y = 9$$

$$x + 2(7) = 9$$

$$x + 14 = 9$$

$$x = -5$$

Check:

$$x + 2y = 9$$

$$-5 + 2(7) = 9$$

$$-5 + 14 = 9$$

$$9 = 9$$

$$3x + 5y = 20$$

$$3(-5) + 5(7) = 20$$

$$-15 + 35 = 20$$

$$20 = 20$$

$$13) \begin{cases} x - 3y = 10 \\ 2x + y = 13 \end{cases} \quad \begin{aligned} x - 3y &= 10 \\ x &= 3y + 10 \end{aligned}$$

$$2x + y = 13$$

$$2(3y + 10) + y = 13$$

$$6y + 20 + y = 13$$

$$7y + 20 = 13$$

$$7y = -7$$

$$y = -1$$

$$x - 3y = 10$$

$$x - 3(-1) = 10$$

$$x + 3 = 10$$

$$x = 7$$

Check:

$$x - 3y = 10$$

$$7 - 3(-1) = 10$$

$$7 + 3 = 10$$

$$10 = 10$$

$$2x + y = 13$$

$$2(7) + (-1) = 13$$

$$14 - 1 = 13$$

$$13 = 13$$

$$14) \begin{cases} y = \frac{1}{4}x - 14 \\ y = \frac{19}{8}x + 7 \end{cases} \quad \text{Solve the system by graphing and substitution}$$

$$\frac{1}{4}x - 14 = \frac{19}{8}x + 7$$

$$\frac{1}{4}x = \frac{19}{8}x + 21$$

$$\frac{2}{8}x - \frac{19}{8}x = 21$$

$$-\frac{17}{8}x = 21$$

$$-2.125x = 21$$

$$x = -9.88$$

$$y = .25x - 14$$

$$y = .25(-9.88) - 14$$

$$y = -2.47 - 14$$

$$y = -16.47$$

Check:

$$y = .25x - 14$$

$$-16.47 = .25(-9.88) - 14$$

$$-16.47 = -2.47 - 14$$

$$-16.47 = -16.47$$

$$y = 2.375x + 7$$

$$-16.47 = 2.375(-9.88) + 7$$

$$-16.47 = -23.465 + 7$$

$$-16.47 = -16.47$$

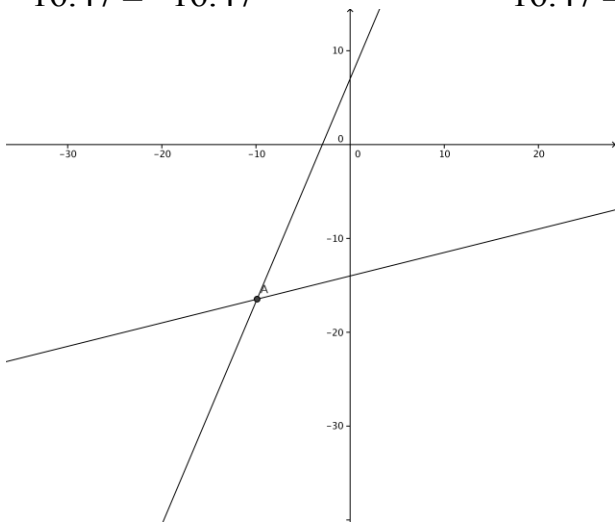

$(-9.88, -16.47)$ is the solution set for these two equations because that is where the two graphs intersect.

Which method do you prefer? Why? *Answers will vary.*

15)

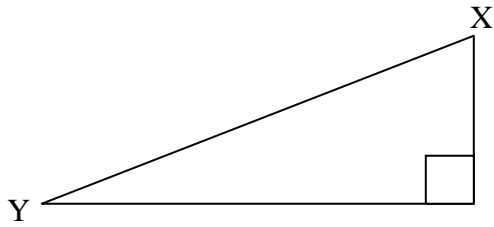

We know that all three angles of any triangle add up to 180 degrees. We also know that a right angle is 90 degrees. That means that the two angles left in the triangle must add up to 90 degrees. $X+Y=90$

We also know that one of the angles is twice the size of the other angle. $X=2Y$

Now we solve the system of equations.

$$\begin{cases} x + y = 90 \\ x = 2y \end{cases}$$

$$x + y = 90$$

$$2y + y = 90$$

$$3y = 90$$

$$y = 30$$

$$x = 2y$$

$$x = 2(30)$$

$$x = 60$$

Check:

$$x + y = 90$$

$$x = 2y$$

$$60 + 30 = 90$$

$$60 = 2(30)$$

$$90 = 90$$

$$60 = 60$$

$$\angle X = 60^\circ$$

$$\angle Y = 30^\circ$$

16)

Let's call the numbers x and y . We know when added together they make 70.

$$x + y = 70$$

We also know the difference between the two numbers is 11. So the larger # minus 11 will equal the smaller number.

$$x - 11 = y$$

Now we solve the system to find the solution set.

$$\begin{cases} x + y = 70 \\ x - 11 = y \end{cases}$$

$$x + y = 70$$

$$x = -y + 70$$

$$x - 11 = y$$

$$x = y + 11$$

$$-y + 70 = y + 11$$

$$-2y + 70 = 11$$

$$-2y = -59$$

$$y = 29.5$$

$$x + 29.5 = 70$$

$$x = 40.5$$

Check:

$$x + y = 70$$

$$29.5 + 40.5 = 70$$

$$70 = 70$$

$$x - 11 = y$$

$$40.5 - 11 = 29.5$$

$$29.5 = 29.5$$

The two numbers are 29.5 and 40.5

17)

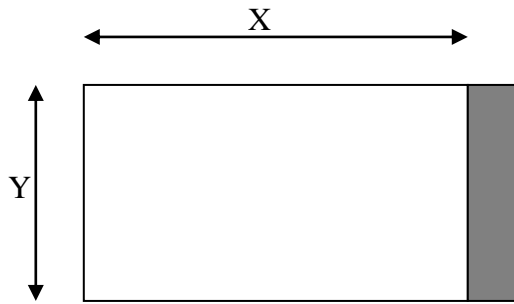

We know that the total perimeter around all four sides is equal to 400 yards. We know that a rectangle has two long equal sides (x) and two shorter equal sides (y). If we combine all four sides we get the perimeter.

$$2x + 2y = 400$$

We also know that the length of the three sides of fence total 320 yards. By looking at the diagram we can figure out that those three sides are x , x , and y . If we add them all together, they equal 320.

$$2x + y = 320$$

Now we solve the system.

$$\begin{cases} 2x + 2y = 400 & 2x + y = 320 \\ 2x + y = 320 & y = -2x + 320 \end{cases}$$

$$2x + 2(-2x + 320) = 400$$

$$2x - 4x + 640 = 400$$

$$-2x + 640 = 400$$

$$-2x = -240$$

$$2x = 240$$

$$x = 120$$

$$2x + y = 320$$

$$2(120) + y = 320$$

$$240 + y = 320$$

$$y = 80$$

Check:

$$2x + 2y = 400$$

$$2(120) + 2(80) = 400$$

$$240 + 160 = 400$$

$$400 = 400$$

$$2x + y = 320$$

$$2(120) + 80 = 320$$

$$240 + 80 = 320$$

$$320 = 320$$

The dimensions of the field are 120 yards by 80 yards.

18)

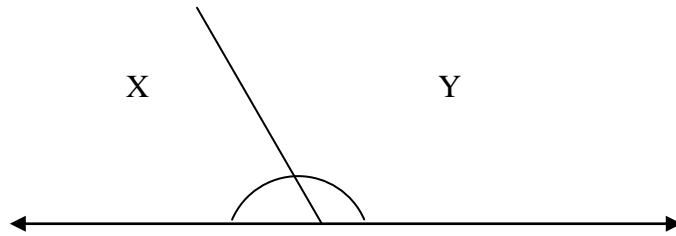

We know that a straight angle (or straight line) is 180 degrees, therefore the two angles together must add up to 180 degrees.

$$x + y = 180$$

We also know that the difference between the angles is 18 degrees. If we subtract 18 from the larger angle, we will get the measure of the smaller angle.

$$x - 18 = y$$

Now we solve the system.

$$\begin{cases} x + y = 180 \\ x - 18 = y \end{cases}$$

$$x + y = 180$$

$$x + (x - 18) = 180$$

$$x + x - 18 = 180$$

$$2x - 18 = 180$$

$$2x = 198$$

$$x = 99$$

$$x - 18 = y$$

$$99 - 18 = y$$

$$y = 81$$

Check:

$$x + y = 180$$

$$99 + 81 = 180$$

$$180 = 180$$

$$x - 18 = y$$

$$99 - 18 = 81$$

$$81 = 81$$

$$\angle X = 99^\circ$$

$$\angle Y = 81^\circ$$

19)

First we have to make the total poundage equal 5. If p is pounds of peanuts and c is pounds of cashews,

$$p + c = 5$$

Next we have to make sure the total cost is \$15.00. Peanuts are 2.2 times p (pounds of peanuts) and Cashews are 4.7 times c (pounds of cashews),

$$2.2p + 4.7c = 15$$

Now we solve the system.

$$\begin{cases} p + c = 5 \\ 2.2p + 4.7c = 15 \end{cases}$$

$$p + c = 5$$

$$p = -c + 5$$

$$2.2p + 4.7c = 15$$

$$2.2(-c + 5) + 4.7c = 15$$

$$-2.2c + 11 + 4.7c = 15$$

$$2.5c + 11 = 15$$

$$2.5c = 4$$

$$c = 1.6$$

$$p + c = 5$$

$$p + 1.6 = 5$$

$$p = 3.4$$

Check:

$$p + c = 5$$

$$3.4 + 1.6 = 5$$

$$5 = 5$$

$$2.2p + 4.7c = 15$$

$$2.2(3.4) + 4.7(1.6) = 15$$

$$7.48 + 1.52 = 15$$

$$15 = 15$$

You should buy 1.6 pounds of peanuts and 3.4 pounds of cashews.

20) The total amount of the liquid needs to be 1 liter. If we call the 10% solution x and the 35% solution y then: $x + y = 1000\text{mL}$

The concentration needs to be 15% of the 1liter. If we change the liter to 1000mL then we figure out 15% we get 150 mL. So 150 mL of the total 1000mL needs to be sulfuric acid. We need to add how much of each solution with a total of 150.

Now we solve the system.

$$\begin{cases} x + y = 1000 \\ 0.1x + .35y = 150 \end{cases}$$

$$x + y = 1000$$

$$x = 1000 - y$$

$$0.1x + .35y = 150$$

$$0.1(1000 - y) + .35y = 150$$

$$100 - 0.1y + .35y = 150$$

$$100 + .25y = 150$$

$$.25y = 50$$

$$y = 200$$

$$x + y = 1000$$

$$x + 200 = 1000$$

$$x = 800$$

Check:

$$x + y = 1000$$

$$800 + 200 = 1000$$

$$1000 = 1000$$

$$0.1x + .35y = 150$$

$$0.1(800) + .35(200) = 150$$

$$80 + 70 = 150$$

$$150 = 150$$

The answer is that 800mL or *0.8L of the 10% solution* and 200mL or *0.2L of the 35% solution* need to be added to get the desired result.

21) The volume of silver used in Bachel's bracelet is 10cc and the volume of gold used is 20 cc.

As the density of gold is 19.3 g/cc, the mass of gold used in her bracelet is $19.3 \times 20 = 386$ g. As the density of silver is 10.5 g/cc, the mass of silver used in her bracelet is $10.5 \times 10 = 105$ g.

The total mass of her bracelet is $105 + 386 = 491$ g
The volume of her bracelet is $10 + 20 = 30$ cc

This allows us to find the density using the formula: density = mass/volume. The density of the bracelet is $491/30 = 16.37$ g/cc

The combined density of her bracelet is 16.37 g/cc

22) The total amount of berries must equal six pounds, if we call blueberries B and raspberries R, then:

$$B + R = 6$$

The total cost must be \$11.60. We must multiply the per pound cost times the number of pounds of raspberries and add it to the per pound cost times the number of pounds of blueberries and the total must equal \$11.60

$$\$1.00(B) + \$2.00(R) = \$11.60$$

$$1B + 2R = 11.60$$

Now lets solve the system:

$$\begin{cases} B + R = 6 \\ 1B + 2R = 11.60 \end{cases}$$

$$B + R = 6$$

$$B = 6 - R$$

$$1B + 2R = 11.60$$

$$1(6 - R) + 2R = 11.60$$

$$6 - R + 2R = 11.60$$

$$6 + R = 11.60$$

$$R = 5.6$$

$$B + R = 6$$

$$B + 5.6 = 6$$

$$B = .4$$

Check:

$$B + R = 6$$

$$.4 + 5.6 = 6$$

$$6 = 6$$

$$1B + 2R = 11.60$$

$$1(.4) + 2(5.6) = 11.60$$

$$.4 + 11.20 = 11.60$$

$$11.60 = 11.60$$

Jeffrey needs 0.4 pounds of blueberries and 5.6 pounds of raspberries.

23)

$$A = l^2$$

$$96 = l^2$$

$$l = \sqrt{96}$$

$$l = 9.7979589$$

24)

$$d = 2r$$

$$11 = 2r$$

$$r = \frac{11}{2}$$

$$r = 5.5$$

$$V = \frac{4}{3} \pi r^3$$

$$V = \frac{4}{3} \left(\frac{22}{7} \right) \left(\frac{11}{2} \right)^3$$

$$V = \frac{44}{21}$$

$$V = 2.1$$

25) The additive inverse is the number that when added to the number we have makes zero, therefore the additive inverse of 7.6 is -7.6.

The multiplicative inverse is the reciprocal of the number, or the number in a reversed fraction. 7.6 is the same as $\frac{76}{10}$ or $\frac{38}{5}$. The reciprocal is $\frac{5}{38}$, therefore the multiplicative inverse of 7.6 is $\frac{5}{38}$.

26) Solve for x : $\frac{1.5}{x} = 6$

$$\frac{1.5}{x} = 6$$

$$1.5 = 6x$$

$$x = \frac{1.5}{6}$$

$$x = .25$$

27)

1. The domain of the function is all numbers ≥ 0 . (We can have any number of cricket chirps, including none, but you can't have negative chirps.)

2. The range of the function is all numbers ≥ 40 . The function is essentially $F = x + 40$ (where x is the number of chirps you heard); therefore the smallest value you can ever get for F is 40 (when x is 0).

3. I would not expect to hear any crickets at 32°F. If the function is correct then we will not hear any crickets for any temperature less than 40. Again, the lowest value we can attain for this function is 40°F.

4. In order to answer this we must first convert the temperature from Celsius to Fahrenheit.

$$F = 1.8C + 32$$

$$F = 1.8(57) + 32$$

$$F = 102.6 + 32$$

$$F = 134.6$$

$$F = x + 40$$

$$134.6 = x + 40$$

$$x = 94.6$$

I would expect to hear 94.6 or about 95 chirps when the temperature is 57°C.

28)

$$45 - 6x \leq 18$$

$$45 - 6(4.5) \leq 18$$

$$45 - 27 \leq 18$$

$$18 \leq 18$$

Yes, 4.5 is a solution.

Lesson 7.3

Solving Linear Systems by Addition or Subtraction

1) The purpose of the elimination method is to eliminate a variable in the system to make solving certain systems faster and easier. The method is appropriate when both equations are in standard form and graphing or using substitution would require a great deal of work.

$$2) \begin{cases} 6x + 3y = -51 \\ 8x - 3y = -19 \end{cases}$$

$$6x + 3y = -51$$

$$+8x - 3y = -19$$

$$14x + 0y = -70$$

$$14x = -70$$

$$x = -5$$

$$6x + 3y = -51$$

$$6(-5) + 3y = -51$$

$$-30 + 3y = -51$$

$$3y = -21$$

$$y = -7$$

Check:

$$6x + 3y = -51$$

$$6(-5) + 3(-7) = -51$$

$$-30 - 21 = -51$$

$$-51 = -51$$

$$8x - 3y = -19$$

$$8(-5) - 3(-7) = -19$$

$$-40 + 21 = -19$$

$$-19 = -19$$

$$3) \begin{cases} 2x + 8y = -18 \\ -2x - 5y = 12 \end{cases}$$

$$-2x - 5y = 12$$

$$\underline{+2x + 8y = -18}$$

$$0x + 3y = -6$$

$$3y = -6$$

$$y = -2$$

$$2x + 8y = -18$$

$$2x + 8(-2) = -18$$

$$2x - 16 = -18$$

$$2x = -2$$

$$x = -1$$

Check:

$$2x + 8y = -18$$

$$2(-1) + 8(-2) = -18$$

$$-2 - 16 = -18$$

$$-18 = -18$$

$$-2x - 5y = 12$$

$$-2(-1) - 5(-2) = 12$$

$$2 + 10 = 12$$

$$12 = 12$$

$$4) \begin{cases} -2x - 5y = -10 \\ 2x + 8y = 16 \end{cases}$$

$$-2x - 5y = -10$$

$$+2x + 8y = 16$$

$$0x + 3y = 6$$

$$3y = 6$$

$$y = 2$$

$$-2x - 5y = -10$$

$$-2x - 5(2) = -10$$

$$-2x - 10 = -10$$

$$-2x = 0$$

$$x = 0$$

Check:

$$-2x - 5y = -10$$

$$-2(0) - 5(2) = -10$$

$$0 - 10 = -10$$

$$-10 = -10$$

$$2x + 8y = 16$$

$$2(0) + 8(2) = 16$$

$$0 + 16 = 16$$

$$16 = 16$$

$$5) \begin{cases} 8x - 24y = -80 \\ -8x + 5y = -15 \end{cases}$$

$$-8x + 5y = -15$$

$$+8x - 24y = -80$$

$$0x - 19y = -95$$

$$-19y = -95$$

$$y = 5$$

$$8x - 24y = -80$$

$$8x - 24(5) = -80$$

$$8x - 120 = -80$$

$$8x = 40$$

$$x = 5$$

Check:

$$8x - 24y = -80$$

$$8(5) - 24(5) = -80$$

$$40 - 120 = -80$$

$$-80 = -80$$

$$-8x + 5y = -15$$

$$-8(5) + 5(5) = -15$$

$$-40 + 25 = -15$$

$$-15 = -15$$

$$6) \begin{cases} -x - 6y = -18 \\ x - 6y = -6 \end{cases}$$

$$-x - 6y = -18$$

$$+x - 6y = -6$$

$$0x - 12y = -24$$

$$-12y = -24$$

$$12y = 24$$

$$y = 2$$

$$x - 6(2) = -6$$

$$x - 12 = -6$$

$$x = 6$$

Check:

$$-x - 6y = -18$$

$$-6 - 6(2) = -18$$

$$-6 - 12 = -18$$

$$-18 = -18$$

$$x - 6y = -6$$

$$6 - 6(2) = -6$$

$$6 - 12 = -6$$

$$-6 = -6$$

$$7) \begin{cases} 5x - 3y = -14 \\ x - 3y = 2 \end{cases}$$

$$x - 3y = 2$$

$$\underline{-5x - 3y = -14}$$

$$-4x + 0y = 16$$

$$-4x = 16$$

$$x = -4$$

$$5x - 3y = -14$$

$$5(-4) - 3y = -14$$

$$-20 - 3y = -14$$

$$-3y = 6$$

$$y = -2$$

Check:

$$5x - 3y = -14$$

$$5(-4) - 3(-2) = -14$$

$$-20 + 6 = -14$$

$$-14 = -14$$

$$x - 3y = 2$$

$$-4 - 3(-2) = 2$$

$$-4 + 6 = 2$$

$$2 = 2$$

$$8) \begin{cases} 3x + 4y = 2.5 \\ 5x - 4y = 25.5 \end{cases}$$

$$3x + 4y = 2.5$$

$$+5x - 4y = 25.5$$

$$8x + 0y = 28$$

$$8x = 28$$

$$x = 3.5$$

$$3x + 4y = 2.5$$

$$3(3.5) + 4y = 2.5$$

$$10.5 + 4y = 2.5$$

$$4y = -8$$

$$y = -2$$

Check:

$$3x + 4y = 2.5$$

$$3(3.5) + 4(-2) = 2.5$$

$$10.5 - 8 = 2.5$$

$$2.5 = 2.5$$

$$5x - 4y = 25.5$$

$$5(3.5) - 4(-2) = 25.5$$

$$17.5 + 8 = 25.5$$

$$25.5 = 25.5$$

$$9) \begin{cases} 5x + 7y = -31 \\ 5x - 9y = 17 \end{cases}$$

$$5x - 9y = 17$$

$$\underline{-5x + 7y = -31}$$

$$0x - 16y = 48$$

$$-16y = 48$$

$$y = -3$$

$$5x + 7y = -31$$

$$5x + 7(-3) = -31$$

$$5x - 21 = -31$$

$$5x = -10$$

$$x = -2$$

Check:

$$5x + 7y = -31$$

$$5(-2) + 7(-3) = -31$$

$$-10 - 21 = -31$$

$$-31 = -31$$

$$5x - 9y = 17$$

$$5(-2) - 9(-3) = 17$$

$$-10 + 27 = 17$$

$$17 = 17$$

$$10) \begin{cases} 3y - 4x = -33 \\ 5x - 3y = 40.5 \end{cases}$$

$$-4x + 3y = -33$$

$$\underline{+5x - 3y = 40.5}$$

$$x + 0y = 7.5$$

$$x = 7.5$$

$$3y - 4x = -33$$

$$3y - 4(7.5) = -33$$

$$3y - 30 = -33$$

$$3y = -3$$

$$y = -1$$

Check:

$$3y - 4x = -33$$

$$3(-1) - 4(7.5) = -33$$

$$-3 - 30 = -33$$

$$-33 = -33$$

$$5x - 3y = 40.5$$

$$5(7.5) - 3(-1) = 40.5$$

$$37.5 + 3 = 40.5$$

$$40.5 = 40.5$$

11) First let's make the cost of a candy bar C and the cost of a fruit roll-up F .

The equation for Nadia's purchase is $3C + 4F = 2.84$

The equation for Peter's purchase is $3C + F = 1.79$

Now let's solve the system.

$$\begin{cases} 3C + 4F = 2.84 \\ 3C + F = 1.79 \end{cases}$$

$$3C + 4F = 2.84$$

$$-(3C + F = 1.79)$$

$$0C + 3F = 1.05$$

$$3F = 1.05$$

$$F = .35$$

$$3C + 4F = 2.84$$

$$3C + 4(.35) = 2.84$$

$$3C + 1.40 = 2.84$$

$$3C = 1.44$$

$$C = .48$$

Check:

$$3C + 4F = 2.84$$

$$3(.48) + 4(.35) = 2.84$$

$$1.44 + 1.40 = 2.84$$

$$2.84 = 2.84$$

$$3C + F = 1.79$$

$$3(.48) + (.35) = 1.79$$

$$1.44 + .35 = 1.79$$

$$1.79 = 1.79$$

Candy bars cost \$0.48 and Fruit roll-ups cost \$0.35

12) Let's make the air-speed x and the wind speed y .

The first plane has its air speed plus the help of the wind. $x + y = 275$

The second plane is air speed minus the wind (it is flying against it) $x - y = 227$

Now let's solve the system.

$$\begin{cases} x + y = 275 \\ x - y = 227 \end{cases}$$

$$x + y = 275$$

$$+x - y = 227$$

$$2x + 0y = 502$$

$$2x = 502$$

$$x = 251$$

$$x + y = 275$$

$$251 + y = 275$$

$$y = 24$$

Check:

$$x + y = 275$$

$$x - y = 227$$

$$251 + 24 = 275$$

$$251 - 24 = 227$$

$$275 = 275$$

$$227 = 227$$

The wind speed is 24 miles per hour.

13)

Let's say that the pickup fee is x and the per mile rate is y .

We are always going to have to add the pickup fee to the price and multiply the per mile rate times the number of miles.

The equation for 12 miles is $x + 12y = 14.29$

The equation for 17 miles is $x + 17y = 19.91$

Now let's solve the system.

$$\begin{cases} x + 12y = 14.29 \\ x + 17y = 19.91 \end{cases}$$

$$x + 12y = 14.29$$

$$-(x + 17y = 19.91)$$

$$0x - 5y = -5.62$$

$$-5y = -5.62$$

$$5y = 5.62$$

$$y = 1.12$$

$$x + 12y = 14.29$$

$$x + 12(1.12) = 14.29$$

$$x + 13.44 = 14.29$$

$$x = 0.85$$

(a) The pickup fee is \$0.85

(b) The per-mile rate is \$1.12

$$.85 + (1.12)7 = c$$

(c) The cost of a seven mile trip is $.85 + 7.84 = c$

$$c = \$8.69$$

(Note, when finding x and y you will have to round to 2 decimal places because we are working with money.)

14)

Let's call the rate for the first 5 minutes x and the rate for the additional minutes y . We would have to multiply the x rate times five and the y rate times the number of minutes over five. If we add these two together we get the total.

For a seven minute call we have $7-5=2$ additional minutes so the equation is:

$$5x + 2y = 4.25$$

For a twelve minute call we have $12-5=7$ additional minutes so the equation is:

$$5x + 7y = 5.50$$

Now let's solve the system.

$$\begin{cases} 5x + 2y = 4.25 \\ 5x + 7y = 5.50 \end{cases}$$

$$5x + 7y = 5.50$$

$$\underline{-(5x + 2y = 4.25)}$$

$$0x + 5y = 1.25$$

$$5y = 1.25$$

$$y = 0.25$$

$$5x + 2y = 4.25$$

$$5x + 2(0.25) = 4.25$$

$$5x + 0.50 = 4.25$$

$$5x = 3.75$$

$$x = 0.75$$

Check:

$$5x + 2y = 4.25$$

$$5(.75) + 2(.25) = 4.25$$

$$3.75 + .50 = 4.25$$

$$4.25 = 4.25$$

$$5x + 7y = 5.50$$

$$5(.75) + 7(.25) = 5.50$$

$$3.75 + 1.75 = 5.50$$

$$5.50 = 5.50$$

The rate for the first 5 minutes is \$0.75 a minute and the rate for each additional minute is \$0.25 a minute.

15)

Let x = the number of hours the plumber worked.

Let y = the number of hours the builder worked.

$\$35x$ represents the amount of money the plumber earned, and $\$28y$ represents the amount of money the builder earned. Together they earned $\$330.75$. Therefore:

$$35x + 28y = 330.75$$

The plumber earned $\$106.75$ more than the builder. Therefore:

$$35x - 28y = 106.75$$

Now let's solve the system.

$$\begin{cases} 35x + 28y = 330.75 \\ 35x - 28y = 106.75 \end{cases}$$

$$35x + 28y = 330.75$$

$$\underline{35x - 28y = 106.75}$$

$$70x + 0y = 437.50$$

$$70x = 437.50$$

$$x = 6.25$$

$$35x + 28y = 330.75$$

$$35(6.25) + 28y = 330.75$$

$$218.75 + 28y = 330.75$$

$$28y = 112$$

$$y = 4$$

Check

$$35x + 28y = 330.75$$

$$35x - 28y = 106.75$$

$$35(6.25) + 28(4) = 330.75$$

$$35(6.25) - 28(4) = 106.75$$

$$218.75 + 112 = 330.75$$

$$218.75 - 112 = 106.75$$

$$330.75 = 330.75$$

$$106.75 = 106.75$$

The plumber worked 6.25 hours and the builder worked 4 hours.

16)

Let's say that his hourly wage is equal to x and the bonus he makes for each warranty is y . We need to multiply his hourly wage (x) times 20 hours and his bonus (y) times the number of warranties he sold in the week. The total of these two is how much he earned in a week.

$$\text{For the first week: } 20x + 8y = 220$$

$$\text{For the second week: } 20x + 13y = 280$$

Now let's solve the system.

$$\begin{cases} 20x + 8y = 220 \\ 20x + 13y = 280 \end{cases}$$

$$20x + 13y = 280$$

$$\underline{-(20x + 8y = 220)}$$

$$0x + 5y = 60$$

$$5y = 60$$

$$y = 12$$

$$20x + 8y = 220$$

$$20x + 8(12) = 220$$

$$20x + 96 = 220$$

$$20x = 124$$

$$x = 6.20$$

Check:

$$20x + 8y = 220$$

$$20(6.20) + 8(12) = 220$$

$$124 + 96 = 220$$

$$220 = 220$$

$$20x + 13y = 280$$

$$20(6.20) + 13(12) = 280$$

$$124 + 156 = 280$$

$$280 = 280$$

Paul makes an hourly wage of \$6.20 and a bonus of \$12 for each warranty he sells.

17) Graph $y = |x| - 5$

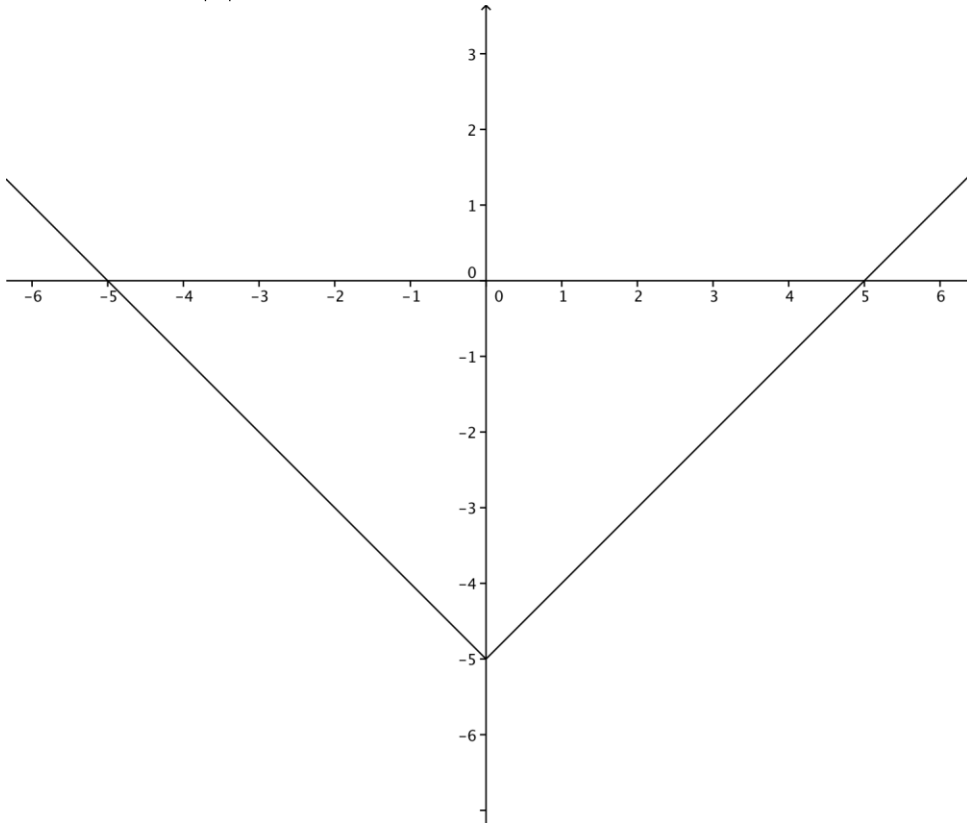

18) Solve:

$$-9 \geq \frac{c}{-4}$$

$$(-9)(-4) \geq c$$

$$36 \geq c$$

$$c \leq 36$$

Interval notation: $(-\infty, 36]$

Number Line:

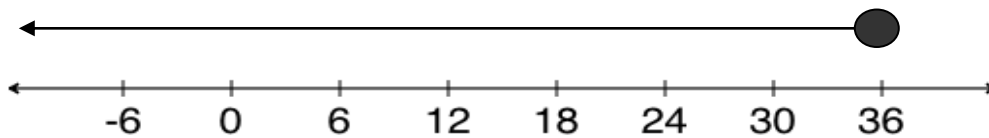

its width. What are the dimensions of the rectangle?

re than

$$A = l \times w$$

$$1440 = 10w \times w$$

$$1440 = 10w^2$$

$$144 = w^2$$

$$\sqrt{144} = w$$

$$w = 12$$

$$l = 10w$$

$$l = 10(12)$$

$$l = 120$$

The width of the rectangle is 12cm and the length is 120 centimeters.

20)

$$f(x) = 8x^2 - 10$$

$$f(-6) = 8(-6^2) - 10$$

$$f(-6) = 8(36) - 10$$

$$f(-6) = 288 - 10$$

$$f(-6) = 278$$

21) First let's convert Torrey's total to square inches so we are working with all the same units. She has $16 \times 144 = 2304$ square inches total. $2304 = 80x + 264y$

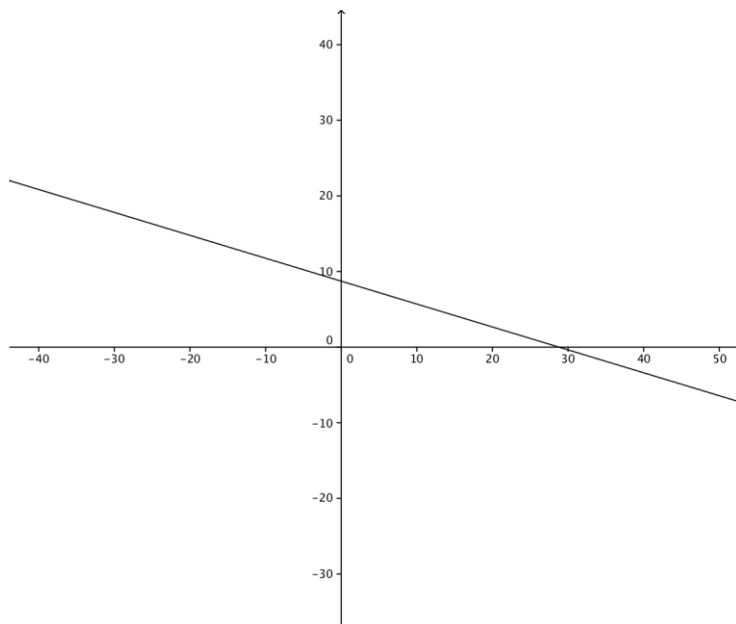

Lesson 7.4
Solving Linear Systems by Multiplication

Find the LCM of

1. 5 and 7 = 35

2. -11 and 6 = 66

3. 15 and 18 = 90

4. 7 and 12 = 84

5. 2 and 17 = 34

6. -3 and 6 = 6

7. 6 and $\frac{1}{3}$ = 6

8. 3 and 111 = 111

9. 9 and 14 = 108

10. 5 and -5 = 5

Find the scalar needed to create the additive inverse.

11. -2

12. -7

13. 8

14. 9

15. -11

16. -4

Solve the systems using multiplication.

$$17. \begin{cases} 5x - 10y = 15 \\ 3x - 2y = 3 \end{cases}$$

$$\begin{aligned} -5(3x - 2y = 3) \\ -15x + 10y = -15 \end{aligned}$$

$$\begin{aligned} 5x - 10y &= 15 \\ -15x + 10y &= -15 \\ \hline -10x + 0y &= 0 \\ -10x &= 0 \\ x &= 0 \end{aligned}$$

$$\begin{aligned} 5x - 10y &= 15 \\ 5(0) - 10y &= 15 \\ 0 - 10y &= 15 \\ -10y &= 15 \\ y &= -1.5 \end{aligned}$$

Check

$5x - 10y = 15$	$3x + 2y = 3$
$5(0) - 10(-1.5) = 15$	$3(0) - 2(-1.5) = 3$
$0 + 15 = 15$	$0 + 3 = 3$
$15 = 15$	$3 = 3$

$$18. \begin{cases} 5x - y = 10 \\ 3x - 2y = -1 \end{cases}$$
$$- 2(5x - y = 10)$$
$$- 10x + 2y = -20$$

$$- 10x + 2y = -20$$

$$+ \underline{3x - 2y = -1}$$

$$- 7x + 0y = -21$$

$$- 7x = -21$$

$$x = 3$$

$$5x - y = 10$$

$$5(3) - y = 10$$

$$15 - y = 10$$

$$- y = -5$$

$$y = 5$$

Check

$$5x - y = 10$$

$$5(3) - 5 = 10$$

$$15 - 5 = 10$$

$$10 = 10$$

$$3x - 2y = -1$$

$$3(3) - 2(5) = -1$$

$$9 - 10 = -1$$

$$-1 = -1$$

$$19. \begin{cases} 5x + 7y = 15 \\ 7x - 3y = 5 \end{cases}$$

$$7(5x + 7y + 15) \rightarrow 35x + 49y = 105$$

$$-5(7x - 3y = 5) \rightarrow -35x + 15y = -25$$

$$35x + 49y = 105$$

$$\underline{-35x + 15y = -25}$$

$$0x + 64y = 80$$

$$64y = 80$$

$$y = 1.25$$

$$5x + 7y = 15$$

$$5x + 7(1.25) = 15$$

$$5x + 8.75 = 15$$

$$5x + 6.25$$

$$x = 1.25$$

Check

$$5x + 7y = 15$$

$$5(1.25) + 7(1.25) = 15$$

$$6.25 + 8.75 = 15$$

$$15 = 15$$

$$7x - 3y = 5$$

$$7(1.25) - 3(1.25) = 5$$

$$8.75 - 3.75 = 5$$

$$5 = 5$$

$$20. \begin{cases} 9x + 5y = 9 \\ 12x + 8y = 12.8 \end{cases}$$

$$4(9x + 5y = 9) \rightarrow 36x + 20y = 36$$

$$-3(12x + 8y = 12.8) \rightarrow -36x - 24y = -38.4$$

$$36x + 20y = 36$$

$$\underline{-36x - 24y = -38.4}$$

$$0x - 4y = -2.4$$

$$-4y = -2.4$$

$$y = .6$$

$$y = \frac{3}{5}$$

$$9x + 5y = 9$$

$$9x + 5\left(\frac{3}{5}\right) = 9$$

$$9x + 3 = 9$$

$$9x = 6$$

$$x = \frac{2}{3} \approx 0.67$$

Check

$$9x + 5y = 9$$

$$9\left(\frac{2}{3}\right) + 5\left(\frac{3}{5}\right) = 9$$

$$6 + 3 = 9$$

$$9 = 9$$

$$12x + 8y = 12.8$$

$$12\left(\frac{2}{3}\right) + 8\left(\frac{3}{5}\right) = 12.8 = 12\frac{8}{10}$$

$$8 + \frac{24}{5} = 12\frac{8}{10} = 12\frac{4}{5}$$

$$8 + 4\frac{4}{5} = 12\frac{4}{5}$$

$$12\frac{4}{5} = 12\frac{4}{5}$$

$$21. \begin{cases} 4x - 3y = 1 \\ 3x - 4y = 4 \end{cases}$$

$$4(4x - 3y = 1) \rightarrow 16x - 12y = 4$$

$$-3(3x - 4y = 4) \rightarrow -9x + 12y = -12$$

$$16x - 12y = 4$$

$$\underline{-9x + 12y = -12}$$

$$7x + 0y = -8$$

$$7x = -8$$

$$x = -\frac{8}{7} \approx -1.14$$

$$4x - 3y = 1$$

$$4\left(-\frac{8}{7}\right) - 3y = 1$$

$$-\frac{32}{7} - 3y = 1$$

$$-3y = 5\frac{4}{7}$$

$$y = 5\frac{4}{7} \div -3$$

$$y = \frac{39}{7} \times -\frac{1}{3}$$

$$y = -\frac{39}{21}$$

$$y = -\frac{13}{7} \approx -1.86$$

Check

$$4x - 3y = 1$$

$$4\left(-\frac{8}{7}\right) - 3\left(-\frac{13}{7}\right) = 1$$

$$-\frac{32}{7} + \frac{39}{7} = 1$$

$$\frac{7}{7} = 1$$

$$1 = 1$$

$$3x - 4y = 4$$

$$3\left(-\frac{8}{7}\right) - 4\left(-\frac{13}{7}\right) = 4$$

$$-\frac{24}{7} + \frac{52}{7} = 4$$

$$\frac{28}{7} = 4$$

$$4 = 4$$

$$22. \begin{cases} 7x - 3y = -3 \\ 6x + 4y = 3 \end{cases}$$

$$\begin{aligned} 4(7x - 3y = -3) &\rightarrow 28x - 12y = -12 \\ 3(6x + 4y = 3) &\rightarrow 18x + 12y = 9 \end{aligned}$$

$$28x - 12y = -12$$

$$\underline{18x + 12y = 9}$$

$$46x + 0y = -3$$

$$46x = -3$$

$$x = -\frac{3}{46} \approx -0.07$$

$$7x - 3y = -3$$

$$7\left(-\frac{3}{46}\right) - 3y = -3$$

$$-\frac{21}{46} - 3y = -3$$

$$-3y = -3 + \frac{21}{46}$$

$$-3y = -\frac{138}{46} + \frac{21}{46}$$

$$-3y = -\frac{117}{46}$$

$$y = -\frac{117}{46} \div -3$$

$$y = -\frac{117}{46} \times \frac{1}{3}$$

$$y = \frac{39}{46} \approx 0.85$$

Check

$$7x - 3y = -3$$

$$7\left(-\frac{3}{46}\right) - 3\left(\frac{39}{46}\right) = -3$$

$$-\frac{21}{46} - \frac{117}{46} = -3$$

$$-\frac{138}{46} = -3$$

$$-3 = -3$$

$$6x + 4y = 3$$

$$6\left(-\frac{3}{46}\right) + 4\left(\frac{39}{46}\right) = 3$$

$$-\frac{18}{46} + \frac{156}{46} = 3$$

$$\frac{138}{46} = 3$$

$$3 = 3$$

$$23. \begin{cases} x = 3y \\ x - 2y = -3 \end{cases}$$

$$x - 2y = -3$$

$$(3y) - 2y = -3$$

$$y = -3$$

$$x = 3y$$

$$x = 3(-3)$$

$$x = -9$$

Check

$$x = 3y$$

$$-9 = 3(-3)$$

$$-9 = -9$$

$$x - 2y = -3$$

$$-9 - 2(-3) = -3$$

$$-9 + 6 = -3$$

$$-3 = -3$$

$$24. \begin{cases} y = 3x + 2 \\ y = 2x + 7 \end{cases}$$

$$3x + 2 = -2x + 7$$

$$3x = -2x + 5$$

$$5x = 5$$

$$x = 1$$

$$y = 3x + 2$$

$$y = 3(1) + 2$$

$$y = 3 + 2$$

$$y = 5$$

Check

$$y = 3x + 2$$

$$5 = 3(1) + 2$$

$$5 = 3 + 2$$

$$5 = 5$$

$$y = -2x + 7$$

$$5 = -2(1) + 7$$

$$5 = -2 + 7$$

$$5 = 5$$

$$25. \begin{cases} 5x - 5y = 5 \\ 5x + 5y = 35 \end{cases}$$

$$5x + 5y = 35$$

$$+ 5x - 5y = 5$$

$$\hline 10x + 0y = 40$$

$$10x = 40$$

$$x = 4$$

$$5x - 5y = 5$$

$$5(4) - 5y = 5$$

$$20 - 5y = 5$$

$$-5y = -15$$

$$y = 3$$

Check

$$5x - 5y = 5$$

$$5(4) - 5(3) = 5$$

$$20 - 15 = 5$$

$$5 = 5$$

$$5x + 5y = 35$$

$$5(4) + 5(3) = 35$$

$$20 + 15 = 35$$

$$35 = 35$$

$$26. \begin{cases} y = -3x - 3 \\ 3x - 2y + 12 = 0 \end{cases}$$

$$3x - 2y + 12 = 0$$

$$3x - 2(-3x - 3) + 12 = 0$$

$$3x + 6x + 6 + 12 = 0$$

$$9x + 18 = 0$$

$$9x = -18$$

$$x = -2$$

$$y = -3x - 3$$

$$y = -3(-2) - 3$$

$$y = 6 - 3$$

$$y = 3$$

Check

$$y = -3x - 3$$

$$3 = -3(-2) - 3$$

$$3 = 6 - 3$$

$$3 = 3$$

$$3x - 2y + 12 = 0$$

$$3(-2) - 2(3) + 12 = 0$$

$$-6 - 6 + 12 = 0$$

$$-12 + 12 = 0$$

$$0 = 0$$

$$27. \begin{cases} 3x - 4y = 3 \\ 4y + 5x = 10 \end{cases}$$

$$4y + 5x = 10 \rightarrow 5x + 4y = 10$$

$$3x - 4y = 3$$

$$\underline{5x + 4y = 10}$$

$$8x + 0y = 13$$

$$8x = 13$$

$$x = \frac{13}{8} \approx 1.63$$

$$3x - 4y = 3$$

$$3\left(\frac{13}{8}\right) - 4y = 3$$

$$\frac{39}{8} - 4y = 3$$

$$-4y = 3 - \frac{39}{8}$$

$$-4y = \frac{24}{8} - \frac{39}{8}$$

$$-4y = -\frac{15}{8}$$

$$y = -\frac{15}{8} \div -\frac{4}{1}$$

$$y = -\frac{15}{8} \times -\frac{1}{4}$$

$$y = \frac{15}{32} \approx 0.47$$

Check

$$3x - 4y = 3$$

$$3\left(\frac{13}{8}\right) - 4\left(\frac{15}{32}\right) = 3$$

$$\frac{39}{8} - \frac{15}{8} = 3$$

$$\frac{24}{8} = 3$$

$$3 = 3$$

$$4y + 5x = 10$$

$$4\left(\frac{15}{32}\right) + 5\left(\frac{13}{8}\right) = 10$$

$$\frac{15}{8} + \frac{65}{8} = 10$$

$$\frac{80}{8} = 10$$

$$10 = 10$$

$$28. \begin{cases} 9x - 2y = -4 \\ 2x - 6y = 1 \end{cases}$$

$$-3(9x - 2y = -4) \rightarrow -27x + 6y = 12$$

$$-27x + 6y = 12$$

$$+ \underline{2x - 6y = 1}$$

$$-25x + 0y = 13$$

$$-25x = 13$$

$$x = -0.52$$

$$2x - 6y = 1$$

$$2(-0.52) - 6y = 1$$

$$-1.04 - 6y = 1$$

$$-6y = 2.04$$

$$y = -0.34$$

Check

$$9x - 2y = -4$$

$$9(-0.52) - 2(-0.34) = -4$$

$$-4.68 + 0.68 = -4$$

$$-4 = -4$$

$$2x - 6y = 1$$

$$2(-0.52) - 6(-0.34) = 1$$

$$-1.04 + 2.04 = 1$$

$$1 = 1$$

29. First we need to create our two equations.

If angles A and B are supplementary then the equation is: $A + B = 180$

If we translate the third sentence into an equation we get: $A = 2B - 18$

Now we solve the system.

$$\begin{cases} A + B = 180 \\ A = 2B - 18 \end{cases}$$

$$A + B = 180$$

$$(2B - 18) + B = 180$$

$$2B - 18 + B = 180$$

$$3B - 18 = 180$$

$$3B = 198$$

$$B = 66$$

$$A = 2B - 18$$

$$A = 2(66) - 18$$

$$A = 132 - 18$$

$$A = 114$$

Angle A is 114° and Angle B is 66° .

30. Let's call the 5% solution a and the 15% solution b . The equation for the total amount of fertilizer is:

$$a + b = 100$$

Let's convert the percentages to decimals (.05, .15 and .12 for the total) Next we have to multiply the amount of solution a by its strength (.05a) and add that to solution b multiplied by its strength (.15b) with the total being .12:

$$.05a + .15b = .12$$

Now let's solve the system.

$$\begin{cases} a + b = 100 \\ 0.05a + 0.15b = .12 \end{cases}$$

$$a + b = 100 \rightarrow a = 100 - b$$

$$0.05a + 0.15b = 0.12$$

$$0.05(100 - b) + 0.15b = 0.12$$

$$5 - 0.05b + 0.15b = 0.12$$

$$5 + 0.10b = 0.12$$

$$0.10b = -4.88$$

$$b = -48.8$$

$$a + b = 100$$

$$a + (-48.8) = 100$$

$$a = 148.8$$

The farmer needs 148.8 liters of the 5% solution and 48.8 liters of the 15% solution.

31.

Let's call the pipe for the first field x and the pipe for the second field y . We know that the pipe for the two fields combined must equal 150 yards. Therefore: $x + y = 150$

We know that the length of the first piece is three yards less than twice the length of the second piece. Therefore: $x = 2y - 3$

Now let's solve the system. We'll use substitution.

$$\begin{cases} x + y = 150 \\ x = 2y - 3 \end{cases}$$

$$x + y = 150$$

$$(2y - 3) + y = 150$$

$$2y - 3 + y = 150$$

$$3y - 3 = 150$$

$$3y = 153$$

$$y = 51$$

$$x = 2y - 3$$

$$x = 2(51) - 3$$

$$x = 102 - 3$$

$$x = 99$$

The length of the first pipe is 99 yards. The length of the second pipe is 51 yards.

32. Let A represent the amount invested in Company A, and B represent the amount invested in company B.

Since we know that Mr. Stein invested a total of \$100,000, it follows that A and B must add up to \$100,000. Therefore: $A + B = 100,000$

Next, we know that he made a return of 8%. 8% of \$100,000 is \$8,000. So 13% of the amount invested (his gain) in A minus 3% of the amount invested in B (his loss) must add up to \$8,000. Therefore: $0.13A - 0.03B = 8000$

Now let's solve the system using substitution.

$$\begin{cases} A + B = 100,000 \\ 0.13A - 0.03B = 8000 \end{cases}$$

$$A + B = 100,000$$

$$A = 100,000 - B$$

$$0.13A - 0.03B = 8000$$

$$0.13(100,000 - B) - 0.03B = 8000$$

$$13000 - 0.13B - 0.03B = 8000$$

$$-0.13B - 0.03B = -5000$$

$$-0.16B = -5000$$

$$B = 31250$$

$$A + B = 100,000$$

$$A + 31250 = 100,000$$

$$A = 68750$$

Mr. Stein invested \$68,750 in Company A and \$31,250 in Company B.

33. First let's figure out how many cakes were sold. 120 to start with 3 left at the end of the day is 117 cakes sold. We'll call plain cakes p and decorated cakes d . Therefore:

$$p + d = 117$$

The baker made \$991 for all the cakes. If the plain cakes cost \$7 and the decorated cakes cost \$11 then the total is: $7p + 11d = 991$

Now let's solve the system. We'll use substitution.

$$\begin{cases} p + d = 117 \\ 7p + 11d = 991 \end{cases}$$

$$p + d = 117 \rightarrow d = 117 - p$$

$$7p + 11d = 991$$

$$7p + 11(117 - p) = 991$$

$$7p + 1287 - 11p = 991$$

$$-4p + 1287 = 991$$

$$-4p = -296$$

$$p = 74$$

$$p + d = 117$$

$$(74) + d = 117$$

$$d = 43$$

The baker sold 74 plain cakes and 43 decorated cakes.

34. Let's call John's age J and Claire's age C . Twice John's age plus five times Claire's age is 204. Therefore: $2J + 5C = 204$

Nine times John's age minus three times Claire's age is also 204. Therefore:
 $9J - 3C = 204$

Now let's solve the system using multiplication and elimination.

$$\begin{cases} 2J + 5C = 204 \\ 9J - 3C = 204 \end{cases}$$

$$3(2J + 5C = 204) \rightarrow 6J + 15C = 612$$

$$5(9J - 3C = 204) \rightarrow 45J - 15C = 1020$$

$$6J + 15C = 612$$

$$\underline{45J - 15C = 1020}$$

$$51J + 0C = 1632$$

$$J = 32$$

$$2J + 5C = 204$$

$$2(32) + 5C = 204$$

$$64 + 5C = 204$$

$$5C = 140$$

$$C = 28$$

Claire is 28 years old and John is 32 years old.

35. Let's make a diagram. The small triangle represents Baxter. He is lying on the ground creating a right angle. His shadow is 3 feet long. The large triangle represents the doghouse. It also creates a right angle with the ground. Its shadow is 8 feet long. The two triangles are similar so we can create a proportion to find Baxter's height.

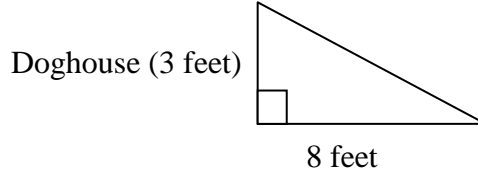
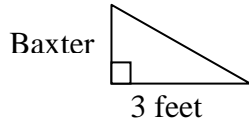

$$\frac{3}{8} = \frac{x}{3}$$
$$9 = 8x$$
$$x = \frac{9}{8} = 1.125$$

The dog is 1.125 feet high.

36. First, let's say that x is the time of growth (in weeks) and y is the height of the lily (in inches).

Next, use the given information to write two points.

At 3 weeks, the lily was 4 inches tall. (3, 4)

Four weeks later, the lily was 21 inches tall. (7, 21)

Now use these points to calculate the slope of the line.

$$m = (y_2 - y_1) / (x_2 - x_1)$$

$$m = (21 - 4) / (7 - 3)$$

$$m = 17/4 = 4.25$$

Now substitute 4.25 in for m in the equation. Also, select one of the points and substitute 3 in for x and 4 in for y . Solve for b .

$$y = mx + b$$

$$4 = 4.25 * 3 + b$$

$$4 = 12.75 + b$$

$$-8.75 = b$$

The equation that represents the growth pattern of this plant is...

(a) $y = 4.25x + -8.75$

To find the height of the lily after 5.5 weeks, substitute 5.5 in for x and solve for y .

$$y = 4.25 * 5.5 + -8.75$$

$$y = 14.625$$

At the 5.5 mark, the height of the lily will be...

(b) 14.625 inches

There is a restriction on how high the plant will grow. A plant will not grow to an unlimited height. For example, after 75 weeks, the lily would reach a height of 310 inches. That's over 25 feet tall.

The equation does not show these restrictions. By definition, a linear equation continues indefinitely in both directions. Lilies grow to a maximum height of only a few feet.

(c) Yes, there is a restriction. No, the equation does not reflect this restriction.

37.

<i>s</i> (number of students in wave)	<i>t</i> (time in seconds to complete on full round)
4	2
8	3.2
12	4
16	5.6
20	7
24	7.9
28	8.6
30	9.1

(a)

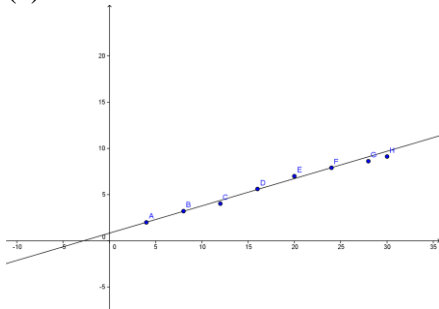

The line of best fit is:

$$\begin{aligned}
 236x + 800y &= 656 \\
 -236(18) + 800y &= 656 \\
 -4248 + 800y &= 656 \\
 800y &= 4904 \\
 y &= 6.13
 \end{aligned}$$

$$(b) \ m = \frac{y - y_1}{x - x_1}$$

$$m = \frac{7 - 5.6}{20 - 16}$$

$$m = \frac{1.4}{4}$$

$$m = 0.35$$

$$y = mx + b$$

$$y = (0.35)x + b$$

$$7 = (0.35)20 + b$$

$$7 = 7 + b$$

$$b = 0$$

$$y = (0.35)x + 0$$

$$y = (0.35)18 + 0$$

$$y = 6.3$$

Quick Quiz

$$1. \begin{cases} -3y = 3x + 6 \\ y = 3x + 4 \end{cases} \quad (-3, -5)$$

$$y = 3x + 4$$

$$-5 = 3(-3) + 4$$

$$-5 = -9 + 4$$

$$-5 = -5$$

$$-3y = 3x + 6$$

$$-3(-5) = 3(-3) + 6$$

$$15 = -9 + 6$$

$$15 \neq -3$$

NO, $(-3, -5)$ is not a solution to the system.

$$2. \begin{cases} y = 6x + 17 \\ y = 7x + 20 \end{cases}$$

$$6x + 17 = 7x + 20$$

$$6x = 7x + 3$$

$$-x = 3$$

$$x = -3$$

$$y = 6x + 17$$

$$y = 6(-3) + 17$$

$$y = -18 + 17$$

$$y = -1$$

Check

$$y = 6x + 17$$

$$-1 = 6(-3) + 17$$

$$-1 = -18 + 17$$

$$-1 = -1$$

$$y = 7x + 20$$

$$-1 = 7(-3) + 20$$

$$-1 = -21 + 20$$

$$-1 = -1$$

3. Let's call the number of cost of the daisies d and the cost of the carnations c .

Joann bought 10 daisies and 4 carnations for \$52.66. Therefore: $10d + 4c = 52.66$

Phyllis bought 3 daisies and 6 carnations for \$43.11. Therefore: $3d + 6c = 43.11$

Now let's solve the system using multiplication and elimination.

$$10d + 4c = 52.66$$

$$3d + 6c = 43.11$$

$$3(10d + 4c = 52.66) \rightarrow 30d + 12c = 157.98$$

$$-2(3d + 6c = 43.11) \rightarrow -6d - 12c = -86.22$$

$$30d + 12c = 157.98$$

$$\underline{-6d - 12c = -86.22}$$

$$24d + 0c = 71.76$$

$$24d = 71.76$$

$$d = 2.99$$

$$10d + 4c = 52.66$$

$$10(2.99) + 4c = 52.66$$

$$29.9 + 4c = 52.66$$

$$4c = 22.76$$

$$c = 5.69$$

Daisies cost \$2.99 each and carnations cost \$5.69 each.

4. Let's say that m stands for mile and c stands for total cost.

Terry's Rental charges \$49 plus \$0.15 per mile. Therefore: $c = 49 + 0.15m$

Hurry-It-Up charges \$84 for the day. Therefore: $c = 84$

Now let's solve the system using substitution.

$$\begin{cases} c = 49 + 0.15m \\ c = 84 \end{cases}$$

$$84 = 49 + 0.15m$$

$$35 = 0.15m$$

$$m \approx 233.33$$

The two companies will charge the same when the mileage reaches 233.33.

Lesson 7.5

Special Types of Linear Systems

1. An *inconsistent system* is a system with no solutions. When graphed, the two equations will be parallel lines (with the same slope, and different y-intercepts).
2. The *three types of consistent systems* are (1) systems with one intersection, (2) systems with two or more intersections, and (3) systems with an infinite number of intersections.
3. You can conclude that the equations in the system are coincident lines that completely overlap. The system has an infinite number of intersections.
4. You can conclude that the equations make up a consistent system.
5. You can verify that the system will have no solution by solving the system algebraically and finding if the final equation has no variables and is untrue.
6. The system on the graph is a consistent system with only one solution.

$$7. \begin{cases} 3x - 4y = 13 \\ y = -3x - 7 \end{cases}$$

$$3x - 4y = 13$$

$$3x - 4(-3x - 7) = 13 \qquad y = -3x - 7$$

$$3x + 12x + 28 = 13 \qquad y = -3(-1) - 7$$

$$15x + 28 = 13 \qquad y = 3 - 7$$

$$15x = -15 \qquad y = -4$$

$$x = -1$$

Check

$$3x - 4y = 13 \qquad y = -3x - 7$$

$$3(-1) - 4(-4) = 13 \qquad -4 = -3(-1) - 7$$

$$-3 + 16 = 13 \qquad -4 = 3 - 7$$

$$13 = 13 \qquad -4 = -4$$

The system is consistent.

$$8. \begin{cases} 4x + y = 3 \\ 12x + 3y = 9 \end{cases}$$

$$-3(4x + y = 3) \rightarrow -12x - 3y = -9$$

$$12x + 3y = 9$$

$$\underline{-12x - 3y = -9}$$

$$0 + 0 = 0$$

$$0 = 0$$

This system is a set of coincident lines with infinite solutions. It is consistent dependent.

$$9. \begin{cases} 10x - 3y = 3 \\ 2x + y = 9 \end{cases}$$

$$2x + y = 9 \rightarrow y = 9 - 2x$$

$$10x - 3y = 3$$

$$10x - 3(9 - 2x) = 3$$

$$10x - 27 + 6x = 3$$

$$16x - 27 = 3$$

$$16x = 30$$

$$x = 1.875$$

$$2x + y = 9$$

$$2(1.875) + y = 9$$

$$3.75 + y = 9$$

$$y = 5.25$$

Check

$$10x - 3y = 3$$

$$10(1.875) - 3(5.25) = 3$$

$$18.75 - 15.75 = 3$$

$$3 = 3$$

$$2x + y = 9$$

$$2(1.875) + 5.25 = 9$$

$$3.75 + 5.25 = 9$$

$$9 = 9$$

This system is consistent.

$$10. \begin{cases} 2x - 5y = 2 \\ 4x + y = 5 \end{cases}$$

$$4x + y = 5$$

$$y = 5 - 4x$$

$$2x - 5y = 2$$

$$2x - 5(5 - 4x) = 2$$

$$2x - 25 + 20x = 2$$

$$22x - 25 = 2$$

$$22x = 27$$

$$x = \frac{27}{22}$$

$$4x + y = 5$$

$$4\left(\frac{27}{22}\right) + y = 5$$

$$\frac{54}{11} + y = 5$$

$$y = 5 - \frac{54}{11}$$

$$y = \frac{55}{11} - \frac{54}{11}$$

$$y = \frac{1}{11}$$

Check

$$2x - 5y = 2$$

$$2\left(\frac{27}{22}\right) - 5\left(\frac{1}{11}\right) = 2$$

$$\frac{27}{11} - \frac{5}{11} = 2$$

$$\frac{22}{11} = 2$$

$$2 = 2$$

$$4x + y = 5$$

$$4\left(\frac{27}{22}\right) + \frac{1}{11} = 5$$

$$\frac{54}{11} + \frac{1}{11} = 5$$

$$\frac{55}{11} = 5$$

$$5 = 5$$

This system is consistent.

$$11. \begin{cases} \frac{3x}{5} + y = 3 \\ 1.2x + 2y = 6 \end{cases}$$

$$\frac{3x}{5} + y = 3 \rightarrow 3x + y = 15 \rightarrow y = 15 - 3x$$

$$1.2x + 2y = 6$$

$$1.2x + 2(15 - 3x) = 6$$

$$1.2x + 30 - 6x = 6$$

$$-4.8x + 30 = 6$$

$$-4.8x = -24$$

$$x = 5$$

$$\frac{3x}{5} + y = 3$$

$$\frac{3(5)}{5} + y = 3$$

$$\frac{15}{5} + y = 3$$

$$3 + y = 3$$

$$y = 0$$

Check

$$\frac{3x}{5} + y = 3$$

$$\frac{3(5)}{5} + 0 = 3$$

$$\frac{15}{5} + 0 = 3$$

$$3 + 0 = 3$$

$$3 = 3$$

$$1.2x + 2y = 6$$

$$1.2(5) + 2(0) = 6$$

$$6 + 0 = 6 = 6 = 6$$

This system is consistent.

$$12. \begin{cases} 3x - 4y = 12 \\ y = -3x - 7 \end{cases}$$

$$3x - 4y = 13$$

$$3x - 4(-3x - 7) = 13$$

$$3x + 12x + 28 = 13$$

$$15x + 28 = 13$$

$$15x = -15$$

$$x = -1$$

$$y = -3x - 7$$

$$y = -3(-1) - 7$$

$$y = 3 - 7$$

$$y = -4$$

Check

$$3x - 4y = 13$$

$$3(-1) - 4(-4) = 13$$

$$-3 + 16 = 13$$

$$13 = 13$$

$$y = -3x - 7$$

$$-4 = -3(-1) - 7$$

$$-4 = 3 - 7$$

$$-4 = -4$$

The system is consistent.

$$13. \begin{cases} 3x - 3y = 3 \\ x - y = 1 \end{cases}$$

$$x - y = 1 \rightarrow x = 1 + y$$

$$3x - 3y = 3$$

$$3(1 + y) - 3y = 3$$

$$3 + 3y - 3y = 3$$

$$3 = 3$$

These equations are coincident lines and the system has infinite solutions. It is consistent dependent.

$$14. \begin{cases} 0.5x - y = 30 \\ 0.5x - y = -30 \end{cases}$$

$$-1(0.5x - y = -30) \rightarrow -0.5x + y = 30$$

$$-0.5x + y = 30$$

$$\underline{0.5x - y = 30}$$

$$0x + 0y = 60$$

$$0 = 60$$

This system has no solutions. It is inconsistent.

$$15. \begin{cases} 4x - 2y = -2 \\ 3x + 2y = -12 \end{cases}$$

$$3x + 2y = -12$$

$$+ 4x - 2y = -2$$

$$\underline{7x + 0y = -14}$$

$$7x = -14$$

$$x = -2$$

$$4x - 2y = -2$$

$$4(-2) - 2y = -2$$

$$-8 - 2y = -2$$

$$-2y = 6$$

$$y = -3$$

Check

$$4x - 2y = -2$$

$$4(-2) - 2(-3) = -2$$

$$-8 + 6 = -2$$

$$-2 = -2$$

$$3x + 2y = -12$$

$$3(-2) + 2(-3) = -12$$

$$-6 - 6 = -12$$

$$-12 = -12$$

This system is consistent.

$$16. \begin{cases} 3x + 2y = 4 \\ -2x + 2y = 24 \end{cases}$$

$$-1(-2x + 2y = 24) \rightarrow 2x - 2y = -24$$

$$3x + 2y = 4$$

$$\underline{2x - 2y = -24}$$

$$5x + 0y = -20$$

$$5x = -20$$

$$x = -4$$

$$3x + 2y = 4$$

$$3(-4) + 2y = 4$$

$$-12 + 2y = 4$$

$$2y = 16$$

$$y = 8$$

Check

$$3x + 2y = 4$$

$$3(-4) + 2(8) = 4$$

$$-12 + 16 = 4$$

$$4 = 4$$

$$-2x + 2y = 24$$

$$-2(-4) + 2(8) = 24$$

$$8 + 16 = 24$$

$$24 = 24$$

This system is consistent.

$$17. \begin{cases} 5x - 2y = 3 \\ 2x - 3y = 10 \end{cases}$$

$$2(5x - 2y = 3) \rightarrow 10x - 4y = 6$$

$$-5(2x - 3y = 10) \rightarrow -10x + 15y = -50$$

$$10x - 4y = 6$$

$$\underline{-10x + 15y = -50}$$

$$0x + 11y = -44$$

$$11y = -44$$

$$y = -4$$

$$5x - 2y = 3$$

$$5x - 2(-4) = 3$$

$$5x + 8 = 3$$

$$5x = -5$$

$$x = -1$$

Check

$$5x - 2y = 3$$

$$5(-1) - 2(-4) = 3$$

$$-5 + 8 = 3$$

$$3 = 3$$

$$2x - 3y = 10$$

$$2(-1) - 3(-4) = 10$$

$$-2 + 12 = 10$$

$$10 = 10$$

This system is consistent.

$$18. \begin{cases} 3x - 4y = 13 \\ y = -3x - y \end{cases}$$

$$y = -3x - y \rightarrow 0 = -3x - 2y$$

$$3x - 4y = 13$$

$$\underline{-3x - 2y = 0}$$

$$0x - 6y = 13$$

$$-6y = 13$$

$$y = -\frac{13}{6}$$

$$3x - 4y = 13$$

$$3x - 4\left(-\frac{13}{6}\right) = 13$$

$$3x + \frac{26}{3} = 13$$

$$3x = 13 - \frac{26}{3}$$

$$3x = \frac{39}{3} - \frac{26}{3}$$

$$3x = \frac{13}{3}$$

$$x = \frac{13}{9}$$

Check

$$3x - 4y = 13$$

$$3\left(\frac{13}{9}\right) - 4\left(-\frac{13}{6}\right) = 13$$

$$\frac{13}{3} + \frac{26}{3} = 13$$

$$\frac{39}{3} = 13$$

$$13 = 13$$

$$y = -3x - y$$

$$-\frac{13}{6} = -3\left(\frac{13}{9}\right) - \left(-\frac{13}{6}\right)$$

$$-\frac{13}{6} = \left(-\frac{13}{3}\right) + \left(\frac{13}{6}\right)$$

$$-\frac{13}{6} = -\frac{26}{6} + \frac{13}{6}$$

$$-\frac{13}{6} = -\frac{13}{6}$$

This system is consistent.

$$19. \begin{cases} 5x - 4y = 1 \\ -10x + 8y = -30 \end{cases} \quad 2(5x - 4y = 1) \rightarrow 10x - 8y = 2$$

$$10x - 8y = 2$$

$$\underline{-10x + 8y = -30}$$

$$0x + 0y = -28$$

$$0 \neq -28$$

This system has no solutions. It is inconsistent.

$$20. \begin{cases} 4x + 5y = 0 \\ 3x = 6y + 4.5 \end{cases}$$

$$3x = 6y + 4.5 \rightarrow 3x - 6y = 4.5$$

$$3(4x + 5y = 0) \rightarrow 12x + 15y = 0$$

$$-4(3x - 6y = 4.5) \rightarrow -12x + 24y = -18$$

$$12x + 15y = 0$$

$$\underline{-12x + 24y = -18}$$

$$0x + 39y = -18$$

$$39y = -18$$

$$y = -\frac{18}{39}$$

$$y = -\frac{6}{13}$$

$$4x + 5y = 0$$

$$4x + 5\left(-\frac{6}{13}\right) = 0$$

$$4x = \frac{30}{13}$$

$$x = -\frac{15}{26}$$

Check

$$4x + 5y = 0$$

$$4\left(\frac{15}{26}\right) + 5\left(-\frac{6}{13}\right) = 0$$

$$\frac{30}{13} - \frac{30}{13} = 0$$

$$0 = 0$$

$$3x = 6y + 4.5$$

$$3\left(\frac{15}{26}\right) = 6\left(-\frac{6}{13}\right) + 4.5$$

$$\frac{45}{26} = -\frac{36}{13} + \frac{117}{26}$$

$$\frac{45}{26} = \frac{45}{26}$$

This system is consistent.

$$21. \begin{cases} -2y + 4x = 8 \\ y - 2x = -4 \end{cases} \quad 2(y - 2x = -4) \rightarrow 2y - 4x = -8$$

$$2y - 4x = -8$$

$$\underline{-2y + 4x = 8}$$

$$0y + 0x = 0$$

$$0 = 0$$

These equations are coincident lines. The system has infinite solutions. It is consistent dependent.

$$22. \begin{cases} x - \frac{y}{2} = \frac{3}{2} \\ 3x + y = 6 \end{cases}$$

$$x - \frac{y}{2} = \frac{3}{2} \rightarrow x = \frac{3}{2} + \frac{y}{2}$$

$$3x + y = 6$$

$$3\left(\frac{3}{2} + \frac{1}{2}y\right) + y = 6$$

$$\frac{9}{2} + \frac{3}{2}y + y = 6$$

$$\frac{3}{2}y + y = 6 - \frac{9}{2}$$

$$\frac{5}{2}y = \frac{3}{2}$$

$$y = \frac{3}{2} \div \frac{5}{2}$$

$$y = \frac{3}{2} \times \frac{2}{5}$$

$$y = \frac{3}{5}$$

$$x - \frac{y}{2} = \frac{3}{2}$$

$$x - \left(\frac{1}{2}\right)\left(\frac{3}{5}\right) = \frac{3}{2}$$

$$x - \frac{3}{10} = \frac{3}{2}$$

$$x = \frac{3}{2} + \frac{3}{10}$$

$$x = \frac{15}{10} + \frac{3}{10}$$

$$x = \frac{18}{10}$$

$$x = \frac{9}{5}$$

Check

$$x - \frac{y}{2} = \frac{3}{2}$$

$$\frac{9}{5} - \frac{1}{2}\left(\frac{3}{5}\right) = \frac{3}{2}$$

$$\frac{9}{5} - \frac{3}{10} = \frac{3}{2}$$

$$\frac{18}{10} - \frac{3}{10} = \frac{3}{2}$$

$$\frac{15}{10} = \frac{3}{2}$$

$$\frac{3}{2} = \frac{3}{2}$$

$$3x + y = 6$$

$$3\left(\frac{9}{5}\right) + \frac{3}{5} = 6$$

$$\frac{27}{5} + \frac{3}{5} = 6$$

$$\frac{30}{5} = 6$$

$$6 = 6$$

This system is consistent.

$$23. \begin{cases} 0.05x + 0.25y = 6 \\ x + y = 24 \end{cases}$$

$$x + y = 24 \rightarrow y = 24 - x$$

$$0.05x + 0.25y = 6$$

$$0.05x + 0.25(24 - x) = 6$$

$$0.05x + 6 - 0.25x = 6$$

$$0.05x - 0.25x = 0$$

$$-0.2x = 0$$

$$x = 0$$

$$x + y = 24$$

$$0 + y = 24$$

$$y = 24$$

Check

$$0.05x + 0.25y = 6$$

$$0.05(0) + 0.25(24) = 6$$

$$0 + 6 = 6$$

$$6 = 6$$

$$x + y = 24$$

$$0 + 24 = 24$$

$$24 = 24$$

This system is consistent.

$$24. \begin{cases} x + \frac{2y}{3} = 6 \\ 3x + 2y = 2 \end{cases}$$

$$-3(x + \frac{2}{3}y = 6) \rightarrow -3x - 2y = -18$$

$$\begin{array}{r} 3x + 2y = 2 \\ -3x - 2y = -18 \\ \hline 0x + 0y = -16 \\ 0 \neq -16 \end{array}$$

OR

$$x + \frac{2y}{3} = 6 \rightarrow x = 6 - \frac{2y}{3}$$

$$\begin{array}{r} 3x + 2y = 2 \\ 3\left(6 - \frac{2y}{3}\right) + 2y = 2 \\ 18 - 2y + 2y = 2 \\ 18 \neq 2 \end{array}$$

This system has no solutions. It is inconsistent.

25. Let's call the number of apples a and the number of bananas b .

Peter buys 2 apples and 3 bananas for \$4. Therefore: $2a + 3b = 4$

Nadia buys 4 apples and six bananas for \$8. Therefore: $4a + 6b = 8$

Now let's solve the system using multiplication and elimination.

$$\begin{cases} 2a + 3b = 4 \\ 4a + 6b = 8 \end{cases} \quad -2(2a + 3b = 4) \rightarrow -4a - 6b = -8$$

$$\begin{array}{r} 4a + 6b = 8 \\ -4a - 6b = -8 \\ \hline 0a + 0b = 0 \\ 0 = 0 \end{array}$$

These equations are coincident lines. The system has infinite solutions. It is consistent dependent.

26. The equation for the membership is $y=45+2x$ and the equation for the second option is $y=3.5x$.

If we graph the equations they look like this.

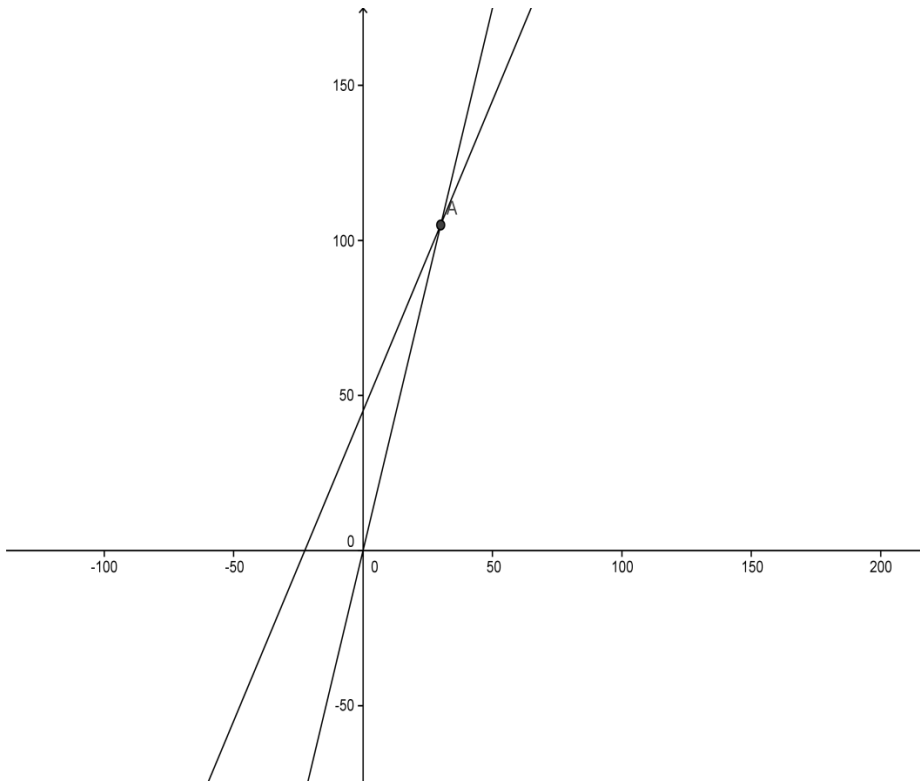

The two lines intersect at $(30,105)$. The two options will cost the same amount at \$105(y) and when a customer has rented 30 movies. If we look at how the lines cross we can see that the membership will cost less after one more movie.

The membership will cost less at 31 movies.

This system is consistent.

27.

Let's call the number of adults a and the number of children c .

The number of adults plus the number of children equals the total number of people.

Therefore: $a + c = 1200$

The total amount of money collected equals the adult ticket price times the number of the adults plus the children's ticket price times the number of children. Therefore:

$$4.5c + 8a = 8375$$

Now let's solve the system by using substitution.

$$\begin{cases} a + c = 1200 \\ 4.5c + 8a = 8375 \end{cases}$$

$$a + c = 1200 \rightarrow c = 1200 - a$$

$$4.5c + 8a = 8375$$

$$4.5(1200 - a) + 8a = 8375$$

$$5400 - 4.5a + 8a = 8375$$

$$5400 + 3.5a = 8375$$

$$3.5a = 2975$$

$$a = 850$$

$$a + c = 1200$$

$$850 + c = 1200$$

$$c = 350$$

The number of adults that day was 850 and the number of children was 350.
This system is consistent.

28. Let's call the per-item cost of the ties T and the per-item cost of the suspenders S .

Andrew's first purchase is 13 ties and 4 suspenders equals \$487.

$$\text{Therefore: } 13T + 4S = 487$$

Andrew's second purchase is 6 ties and 2 suspenders equals \$232.

$$\text{Therefore: } 6T + 2S = 232$$

Now let's solve the system using multiplication and elimination.

$$\begin{cases} 13T + 4S = 487 \\ 6T + 2S = 232 \end{cases}$$

$$-2(6T + 2S = 232) \rightarrow -12T - 4S = -464$$

$$13T + 4S = 487$$

$$\underline{-12T - 4S = -464}$$

$$T + 0S = 23$$

$$T = 23$$

$$6T + 2S = 232$$

$$6(23) + 2S = 232$$

$$138 + 2S = 232$$

$$2S = 94$$

$$S = 47$$

Ties cost \$23 and suspenders cost \$47.

This system is consistent.

29. Let's call the speed of the airplane x and the speed of the jet-stream y .

On the first trip the plane takes four hours with help from the speed of the jet stream.

$$\text{Therefore: } 4x + 4y = 2400$$

On the trip back the plane takes five hours and it is moving against the jet stream.

$$\text{Therefore: } 5x - 5y = 2400$$

Now let's solve the system using elimination.

$$\begin{cases} 4x + 4y = 2400 \\ 5x - 5y = 2400 \end{cases}$$

$$5(4x + 4y = 2400) \rightarrow 20x + 20y = 12000$$

$$4(5x - 5y = 2400) \rightarrow 20x - 20y = 9600$$

$$20x + 20y = 12000$$

$$20x - 20y = 9600$$

$$\hline 40x + 0y = 21600$$

$$40x = 21600$$

$$x = 540$$

$$4x + 4y = 2400$$

$$4(540) + 4y = 2400$$

$$2160 + 4y = 2400$$

$$4y = 240$$

$$y = 60$$

The speed of the airplane is 540 miles per hour and the speed of the jet-stream is 60 miles per hour. This system is consistent.

30.

Let's call the cost of an apple A and the cost of a banana B .

We need to find out the cost of one of each.

The first purchase was two apples and one banana for a total of \$2.50.

Therefore: $2A + B = 2.5$

The second purchase was four apples and two bananas for a total of \$6.00.

Therefore: $4A + 2B = 6$

Now let's solve the system using substitution.

$$\begin{cases} 2A + B = 2.5 \\ 4A + 2B = 6 \end{cases}$$

$$2A + B = 2.5 \rightarrow B = 2.5 - 2A$$

$$4A + 2B = 6$$

$$4A + 2(2.5 - 2A) = 6$$

$$4A + 5 - 4A = 6$$

$$5 \neq 6$$

This system has no solutions. It is inconsistent.

Mixed Review

31.

Let's call the number of regular seats R and the number of box seats B .

We know the total number of all kinds of seats is 10,413. Therefore: $R + B = 10413$

We know that the number of regular seats is twelve times the number of box seats.

Therefore: $R = 12B$

Now let's solve the system using substitution.

$$\begin{cases} R + B = 10413 \\ R = 12B \end{cases}$$

$$R + B = 10413$$

$$(12B) + B = 10413$$

$$13B = 10413$$

$$B = 801$$

$$R = 12B$$

$$R = 12(801)$$

$$R = 9612$$

There are 9,612 regular seats in the stadium and 801 box seats in the stadium.

$$32. \quad y = -\frac{3}{5}x - 8.5$$

$$(2,7)$$

The slope of the line is $-3/5$ so the slope of a line perpendicular to it is $5/3$ (the reciprocal with the opposite sign). Now let's use point slope form to find the equation of the line.

$$y - y_1 = m(x - x_1)$$

$$y - 7 = \frac{5}{3}(x - 2)$$

$$y - 7 = \frac{5}{3}x - \frac{10}{3}$$

$$y = \frac{5}{3}x - \frac{10}{3} + 7$$

$$y = \frac{5}{3}x - \frac{10}{3} + \frac{21}{3}$$

$$y = \frac{5}{3}x + \frac{11}{3}$$

$$33. \quad y = \frac{1}{6}x - 4$$

Standard form is $ax + by = c$

$$y = \frac{1}{6}x - 4$$

$$4 + y = \frac{1}{6}x$$

$$4 = \frac{1}{6}x - y$$

$$\frac{1}{6}x - y = 4$$

$$34. \quad 7\frac{2}{3} + \frac{4}{5}$$

$$7\frac{2}{3} + \frac{4}{5} = \frac{23}{3} + \frac{4}{5} = \frac{115}{15} + \frac{12}{15} = \frac{127}{15} = 8\frac{7}{15}$$

$$35. \frac{7}{8} \div -\frac{2}{3}$$

$$\frac{7}{8} \div -\frac{2}{3} = \frac{7}{8} \times -\frac{3}{2} = -\frac{21}{16}$$

36. Yes the product of two rational numbers is always a rational number. Regardless of what answer you get, it can always be represented as a ratio of two integers, a rational number. If the answer is a whole number we can always put a one in the denominator to make it a ratio.

Lesson 7.6 Systems of Linear Inequalities

1. *Linear Programming* is the mathematical process of analyzing a system of inequalities to make the best decisions given the constraints of the situation.
2. The *feasible region* of a system of inequalities is the region on the graph that represents the solutions that fit all the inequalities of the system.
3. Constraints are the particular restrictions of a situation due to time, money or materials. They limit the possible solutions to a system of inequalities.
4. An *optimization equation* is an equation that allows you to find the maximum number of solutions. Its purpose is to find the best possible solution for the system of inequalities in your given situation (i.e. most money etc).
5. The *maximum or minimum points of the optimization equation* are located at the vertices of the feasible region, where the boundary lines intersect.

$$6. \begin{cases} 4y - 5x < 8 \\ -5x \geq 16 - 8y \end{cases} \quad \begin{aligned} 4y - 5x < 8 &\rightarrow y < \frac{5}{4}x + 2 \\ -5x \geq 16 - 8y &\rightarrow y \geq \frac{5}{8}x + 2 \end{aligned}$$

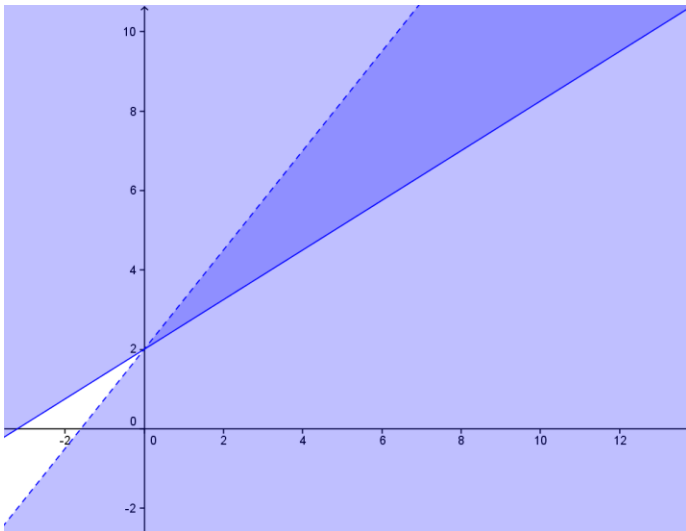

$$7. \begin{cases} 5x - y \geq 5 \\ 2y - x \geq -10 \end{cases} \quad \begin{aligned} 5x - y \geq 5 &\rightarrow y \leq 5x - 5 \\ 2y - x \geq -10 &\rightarrow y \geq \frac{1}{2}x - 5 \end{aligned}$$

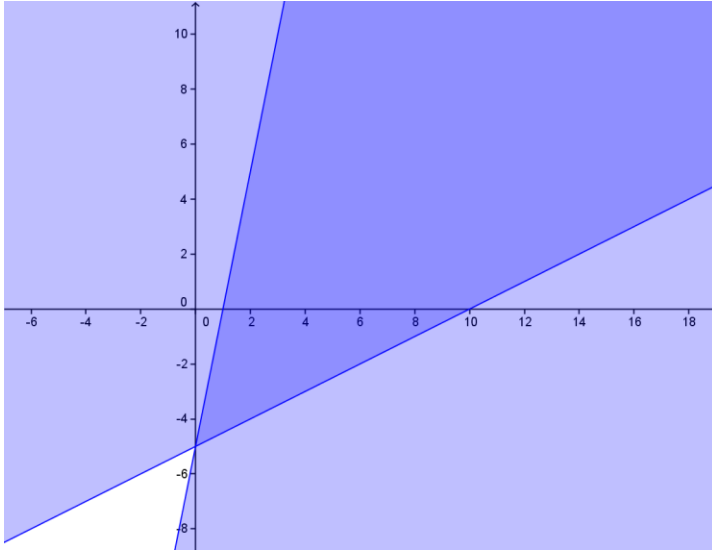

$$8. \begin{cases} 2x - 3y \leq 21 \\ x + 4y \leq 6 \\ 3x + y \geq -4 \end{cases} \quad \begin{aligned} 2x - 3y \leq 21 &\rightarrow y \geq \frac{2}{3}x - 7 \\ x + 4y \leq 6 &\rightarrow y \leq -\frac{1}{4}x + \frac{3}{2} \\ 3x + y \geq -4 &\rightarrow y \geq -3x - 4 \end{aligned}$$

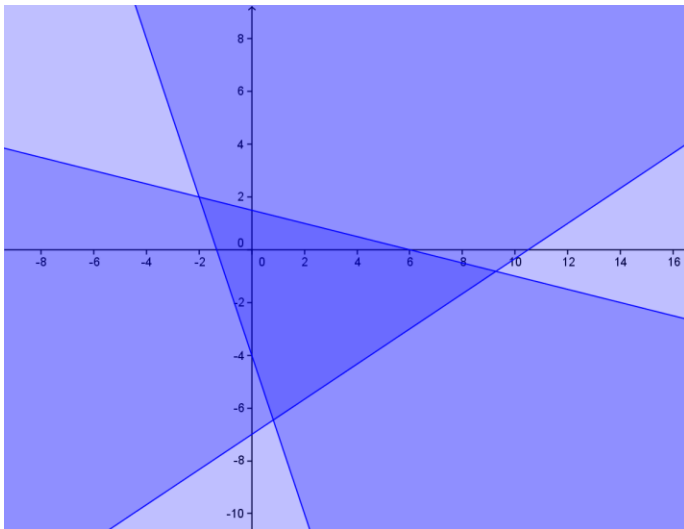

$$9. \begin{cases} y \geq \frac{1}{4}x - 3 \\ y < \frac{13}{8}x + 8 \end{cases}$$

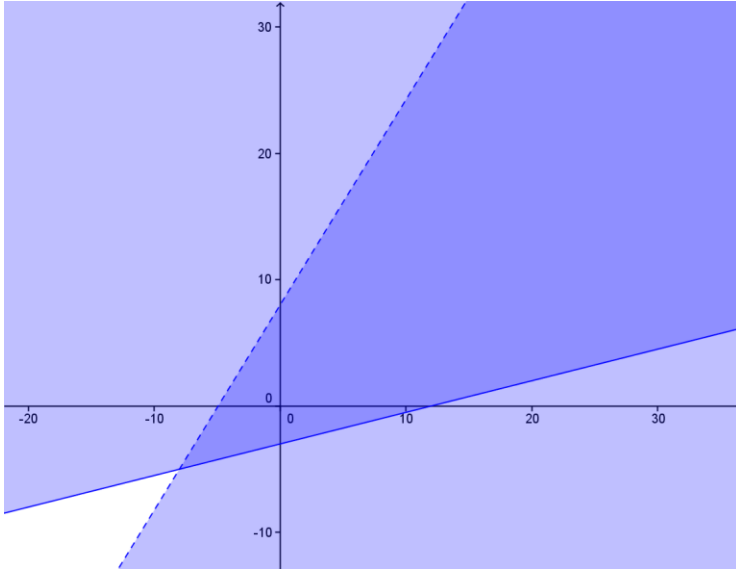

$$10. \begin{cases} y \leq \frac{3}{4}x - 5 \\ y \geq -2x + 2 \end{cases}$$

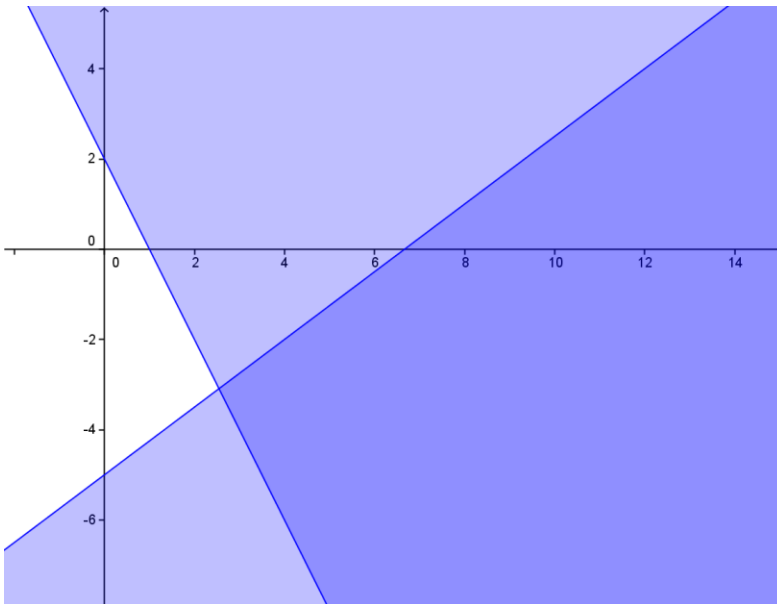

$$11. \begin{cases} y > -x+1 \\ y > \frac{1}{4}x+6 \end{cases}$$

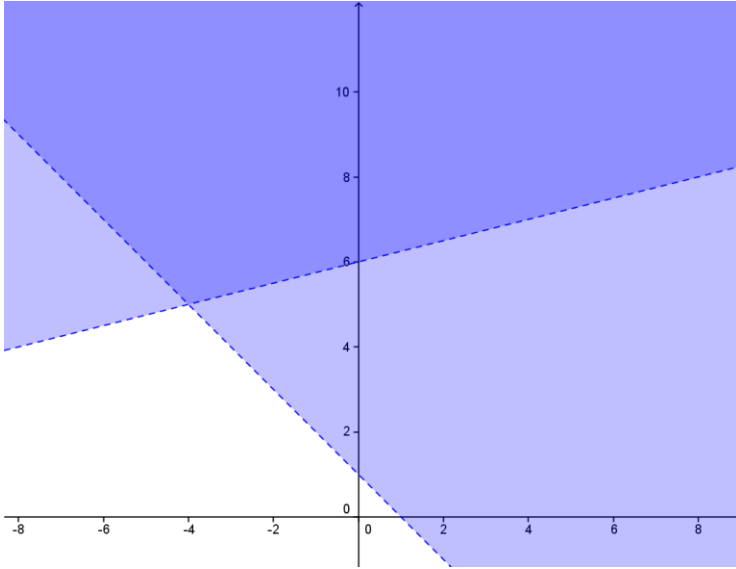

$$12. \begin{cases} y > -\frac{1}{2}x+4 \\ x < -4 \end{cases}$$

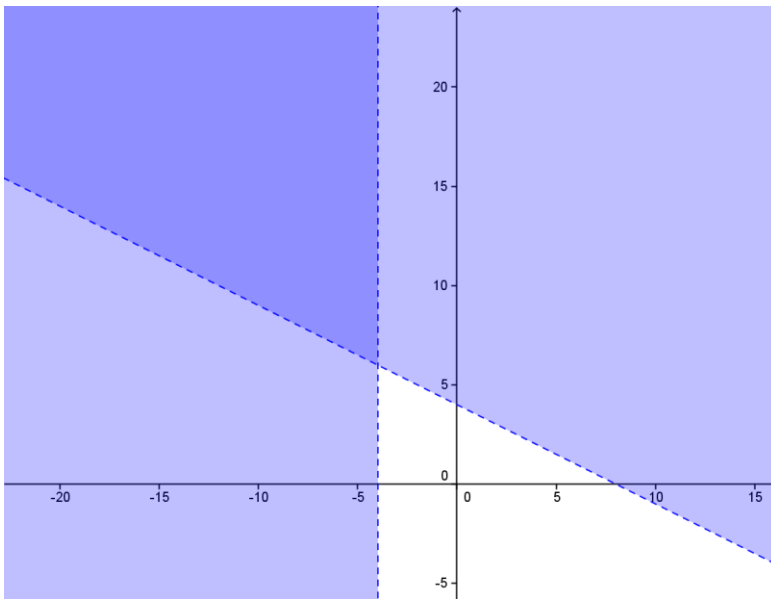

$$13. \begin{cases} y \leq 6 \\ y > \frac{1}{4}x + 6 \end{cases}$$

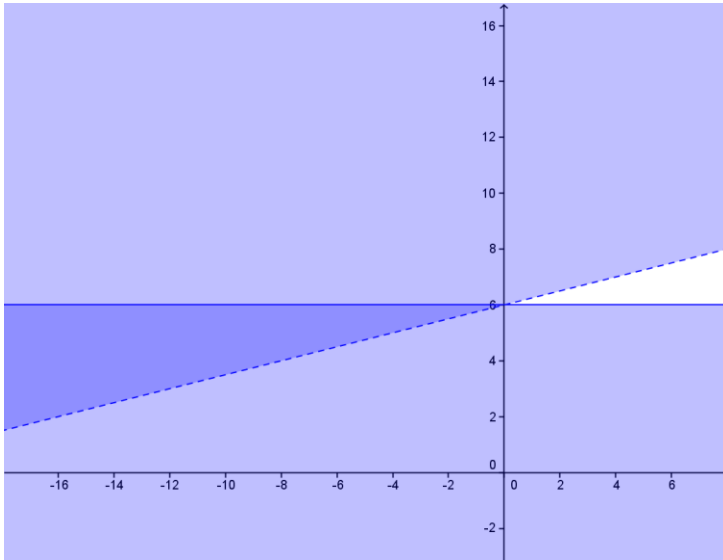

14.

$$x - y = -6$$

$$-y = -6 - x$$

$$y = 6 = x$$

$$y = x + 6$$

$$y > x + 6$$

$$2y = 3x + 17$$

$$y = \frac{3}{2}x + \frac{17}{2}$$

$$y \geq \frac{3}{2}x + \frac{17}{2}$$

$$y \geq \frac{3}{2}x + 8\frac{1}{2}$$

$$\begin{cases} y > x + 6 \\ y \geq \frac{3}{2}x + 8\frac{1}{2} \end{cases}$$

15.

$$x+4y=6$$

$$4y=-x+6$$

$$y=-\frac{1}{4}x+\frac{3}{2}$$

$$y=-\frac{1}{4}x+1\frac{1}{2}$$

$$y\leq-\frac{1}{4}x+1\frac{1}{2}$$

$$2x-3y=21$$

$$-3y=-2x+21$$

$$y=\frac{2}{3}x-7$$

$$y\geq\frac{2}{3}x-7$$

$$3x+4y=-4$$

$$4y=-3x-4$$

$$y=-\frac{3}{4}x-1$$

$$y\geq-\frac{3}{4}x-1$$

$$\begin{cases} y\leq-\frac{1}{4}x+1\frac{1}{2} \\ y\geq\frac{2}{3}x-7 \\ y\geq-\frac{3}{4}x-1 \end{cases}$$

16.

$$2x+y=12$$

$$y=-2x+12$$

$$y\leq-2x+12$$

$$2x-8y=36$$

$$-8y=-2x+36$$

$$y=\frac{1}{4}x+4\frac{1}{2}$$

$$y\leq\frac{1}{4}x+4\frac{1}{2}$$

$$12x-7y=120$$

$$-7y=-12x+120$$

$$y=\frac{12}{7}x-\frac{120}{7}$$

$$y>\frac{12}{7}x-\frac{120}{7}$$

$$\begin{cases} y\leq-2x+12 \\ y\leq\frac{1}{4}x+4\frac{1}{2} \\ y>\frac{12}{7}x-\frac{120}{7} \end{cases}$$

$$17. z = -x + 5y$$

$$x + 3y \leq 0$$

$$x - y \geq 0$$

$$3x - 7y \leq 16$$

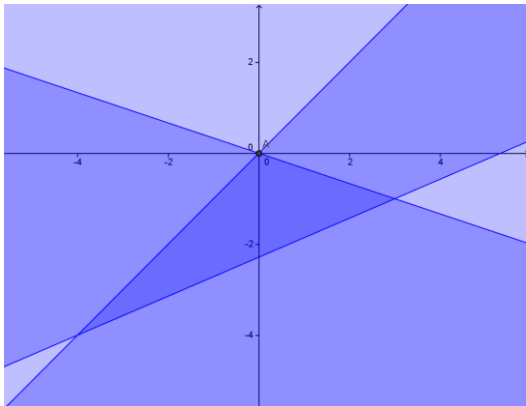

$$(0,0) (4,-4) (3,-1)$$

$$z = -x + 5y$$

$$z = -0 + 5(0)$$

$$z = 0$$

$$z = -x + 5y$$

$$z = -(4) + 5(-4)$$

$$z = -4 - 20$$

$$z = -20$$

$$z = -x + 5y$$

$$z = -(3) + 5(-1)$$

$$z = -3 - 5$$

$$z = -8$$

The maximum value of z is 0 and the minimum value of z is -20.

$$18. z = 2x + 5y$$

$$2x - y \leq 12$$

$$4x + 3y \geq 0$$

$$x - y \geq 6$$

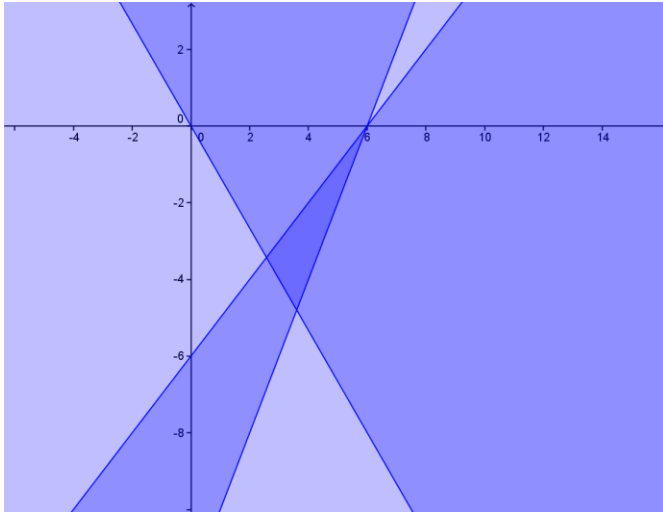

$$(6,0) \quad (4,-5) \quad (2.5,-3)$$

$$z = 2x + 5y$$

$$z = 2(6) + 5(0)$$

$$z = 12 + 0$$

$$z = 12$$

$$z = 2x + 5y$$

$$z = 2(4) + 5(-5)$$

$$z = 8 - 25$$

$$z = -17$$

$$z = 2x + 5y$$

$$z = 2(2.5) + 5(-3)$$

$$z = 5 - 15$$

$$z = -10$$

The maximum value of z is 12 and the minimum value is -17.

19.

Let's call z the maximum profit, x the number of bookcases, and y the number of TV stands.

We are trying to find the maximum profit: $z=60x+100y$

His time constraint is: $x + y \leq 18$

His money constraint is: $20x + 45y \leq 600$

Also: $x \geq 0$
 $y \geq 0$ because you cannot make negative furniture.

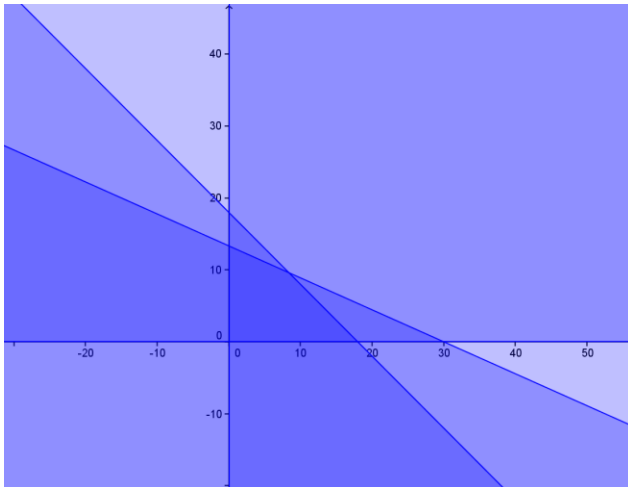

(0,0) (18,0) (8,10) (0,14)

$z = 60x + 100y$	$z = 60x + 100y$	$z = 60x + 100y$	$z = 60x + 100y$
$z = 60(0) + 100(0)$	$z = 60(18) + 100(0)$	$z = 60(8) + 100(10)$	$z = 60(0) + 100(14)$
$z = 0$	$z = 1080 + 0$	$z = 480 + 1000$	$z = 0 + 1400$
	$z = 1080$	$z = 1480$	$z = 1400$

Andrew should make 8 bookcases and 10 TV stands for a maximum profit of \$1480.

20.

x = Amount of municipal bonds

y = Amount of CD's

z = Amount of high risk

Maximize $1.05x+1.07y+1.10z$

$$x + y + z = 10000$$

$$z \leq 1000$$

$$z \geq 0$$

$$x \geq 3y$$

$$x \geq 0$$

$$y \geq 0$$

To maximize your return, you want to invest the maximum in high risk = \$1000.

You now have \$9000, you want to invest the maximum in CD's, but for tax purposes you need 3 times as much invested in municipal bonds than CD's.

So $3y + y = \$9000$, this solves to $y = \$2250$.

And $x = 3y = \$6750$.

So the answer is \$6750 in municipal bonds, \$2250 in CD's, and \$1000 in high risk.

Mixed Review

21. Solve by elimination $\begin{cases} 12x + 8y = 24 \\ -6x + 3y = 9 \end{cases}$ $2(-6x + 3y = 9) \rightarrow -12x + 6y = 18$

$$\begin{array}{r} 12x + 8y = 24 \\ -12x + 6y = 18 \\ \hline 0x + 14y = 42 \\ 14y = 42 \\ y = 3 \end{array} \quad \begin{array}{r} -6x + 3y = 9 \\ -6x + 3(3) = 9 \\ -6x + 9 = 9 \\ -6x = 0 \\ x = 0 \end{array}$$

Check

$$\begin{array}{r} 12x + 8y = 24 \\ 12(0) + 8(3) = 24 \\ 0 + 24 = 24 \\ 24 = 24 \end{array} \quad \begin{array}{r} -6x + 3y = 9 \\ -6(0) + 3(3) = 9 \\ 0 + 9 = 9 \\ 9 = 9 \end{array}$$

22. Solve $36 = |5t - 6|$

$$36 = |5t - 6|$$

$$36 = 5t - 6$$

$$42 = 5t$$

$$t = |8.4|$$

$$t = 8.4$$

23. Determine the intercepts of $y = -\frac{5}{6}x - 3$

$$y = -\frac{5}{6}x - 3$$

$$0 = -\frac{5}{6}x - 3$$

$$3 = -\frac{5}{6}x$$

$$x = 3 \div -\frac{5}{6}$$

$$x = \frac{3}{1} \times -\frac{6}{5}$$

$$x = -\frac{18}{5} = -3\frac{3}{5} = -3.6$$

Since the equation is in $y=mx+b$ form, we know the y-intercept is -3

x-intercept: $(-3.6, 0)$

y-intercept: $(0, -3)$

24.

Assume that the x-axis is the axis of time and y-axis represents the axis of earnings. We'll identify $x_1 = 3h$, $x_2 = 9h$, $y_1 = \$145$, $y_2 = \$355$

The point slope formula of the linear equation is:

$$y - y_1 = m(x - x_1)$$

The equation for m (slope) is:

$$m = \frac{y_2 - y_1}{x_2 - x_1}$$

$$m = \frac{355 - 145}{9 - 3}$$

$$m = \frac{210}{6}$$

$$m = 35$$

$$y - y_1 = m(x - x_1)$$

$$y - 145 = 35(x - 3)$$

$$y - 145 = 35x - 105$$

$$y = 35x - 105 + 145$$

$$y = 35x + 40$$

$$y = 35x + 40$$

$$y = 35(1.25) + 40$$

$$y = 43.75 + 40$$

$$y = 83.75$$

Jerry's aunt would charge \$83.75 for 1.25 hours worth of work.

25.

Yoder is y, Kate is k and Dylan is d.

$$y = k - 4$$

$$k = d - 6$$

$$d = 20$$

If Dylan is 20 then Kate is 14 and Yoder is 10.

Lesson 7.7

Probability and Permutation

1. A *permutation* is an arrangement of objects in a specific order. It is the product of the counting numbers 1 through n .

2. $7! = 7 \cdot 6 \cdot 5 \cdot 4 \cdot 3 \cdot 2 \cdot 1 = 5040$

3. $10! = 10 \cdot 9 \cdot 8 \cdot 7 \cdot 6 \cdot 5 \cdot 4 \cdot 3 \cdot 2 \cdot 1 = 3628800$

4. $1! = 1 \cdot 1 = 1$

5. $5! = 5 \cdot 4 \cdot 3 \cdot 2 \cdot 1 = 120$

6. $9! = 9 \cdot 8 \cdot 7 \cdot 6 \cdot 5 \cdot 4 \cdot 3 \cdot 2 \cdot 1 = 362880$

7. $3! = 3 \cdot 2 \cdot 1 = 6$

8.

$$4! + 4!$$

$$4! = 4 \cdot 3 \cdot 2 \cdot 1 = 24$$

$$4! + 4! = 24 + 24 = 48$$

9.

$$16! - 5!$$

$$16! = 16 \cdot 15 \cdot 14 \cdot 13 \cdot 12 \cdot 11 \cdot 10 \cdot 9 \cdot 8 \cdot 7 \cdot 6 \cdot 5 \cdot 4 \cdot 3 \cdot 2 \cdot 1 = 20922789888000$$

$$5! = 5 \cdot 4 \cdot 3 \cdot 2 \cdot 1 = 120$$

$$16! - 5! = 20922789888000 - 120 = 20922789887880$$

10. $\frac{98!}{96!} = \frac{98 \cdot 97}{1} = 9506$

11. $\frac{11!}{2!} = \frac{11 \cdot 10 \cdot 9 \cdot 8 \cdot 7 \cdot 6 \cdot 5 \cdot 4 \cdot 3}{1} = 19958400$

12. $\frac{301!}{300!} = \frac{301}{1} = 301$

13. $\frac{8!}{3!} = \frac{8 \cdot 7 \cdot 6 \cdot 5 \cdot 4}{1} = 6720$

14.

$$2!+9!$$

$$2! = 2 \cdot 1 = 2$$

$$9! = 9 \cdot 8 \cdot 7 \cdot 6 \cdot 5 \cdot 4 \cdot 3 \cdot 2 \cdot 1 = 362880$$

$$2!+9! = 2 + 362880 = 362882$$

$$15. {}_{11}P_2 = \frac{11!}{(11-2)!} = \frac{11!}{9!} = 11 \cdot 10 = 110$$

$$16. {}_5P_5 = \frac{5!}{(5-5)!} = \frac{5!}{0!} = 5 \cdot 4 \cdot 3 \cdot 2 \cdot 1 = 120$$

$$17. {}_5P_3 = \frac{5!}{(5-3)!} = \frac{5!}{2!} = 5 \cdot 4 \cdot 3 = 60$$

$$18. {}_{15}P_{10} = \frac{15!}{(15-10)!} = \frac{15!}{5!} = 15 \cdot 14 \cdot 13 \cdot 12 \cdot 11 \cdot 10 \cdot 9 \cdot 8 \cdot 7 \cdot 6 = 10897286400$$

19.

$${}_{60}P_{59} = \frac{60!}{(60-59)!} = \frac{60!}{1!} = 60! =$$

8320987112741390144276341183223364380754172606361245952449277696409600000000000000

$$20. \quad 14! = 14 \cdot 13 \cdot 12 \cdot 11 \cdot 10 \cdot 9 \cdot 8 \cdot 7 \cdot 6 \cdot 5 \cdot 4 \cdot 3 \cdot 2 \cdot 1 = 87178291200$$

$$21. \quad {}_{10}P_4 = \frac{10!}{(10-4)!} = \frac{10!}{6!} = 10 \cdot 9 \cdot 8 \cdot 7 = 5040$$

22.

$${}_{21}P_{13} = \frac{21!}{(21-13)!} = \frac{21!}{8!} = 21 \cdot 20 \cdot 19 \cdot 18 \cdot 17 \cdot 16 \cdot 15 \cdot 14 \cdot 13 \cdot 12 \cdot 11 \cdot 10 \cdot 9 = 1267136462592000$$

$$23. \quad 8! = 8 \cdot 7 \cdot 6 \cdot 5 \cdot 4 \cdot 3 \cdot 2 \cdot 1 = 40320$$

24.

(a)

The first place can be won by either of the 12 horses, this gives 12 ways for it to happen. Once the first place has been secured, the second place can be won by either of the remaining 11 horses. This can happen in 11 ways. In total we have $12 \cdot 11 = 132$ ways

(b)

Now let's find the number of ways in which all the horses finish the race. The 1st horse can finish at any of the 12 places. The 2nd can finish at any of the remaining 11 places. This goes on till there is one place left for the last horse. Therefore:

$$12! = 12 \cdot 11 \cdot 10 \cdot 9 \cdot 8 \cdot 7 \cdot 6 \cdot 5 \cdot 4 \cdot 3 \cdot 2 \cdot 1 = 479001600$$

25. $6! = 6 \cdot 5 \cdot 4 \cdot 3 \cdot 2 \cdot 1 = 720$

26. It is given that Jerry, Kerry, Larry, and Mary are waiting at a bus stop. The number of ways that the 4 can get into the bus is given by

$${}_4P_4 = \frac{4!}{(4-4)!} = 4! = 4 \cdot 3 \cdot 2 \cdot 1 = 24$$

The number of ways in which Mary gets on to the bus first is

$${}_3P_3 = \frac{3!}{(3-3)!} = 3! = 3 \cdot 2 \cdot 1 = 6$$

The probability that Mary gets on the bus first is $\frac{6}{24} = \frac{1}{4}$

27. $5! = 5 \cdot 4 \cdot 3 \cdot 2 \cdot 1 = 120$

28. For the word AMAZING, A is repeated twice. The number of permutations can be found by dividing the factorial of the total number of letters by the factorial of the number of times the letter A repeats.

$$\frac{7!}{2!} = \frac{7 \cdot 6 \cdot 5 \cdot 4 \cdot 3 \cdot 2 \cdot 1}{2 \cdot 1} = 7 \cdot 6 \cdot 5 \cdot 4 \cdot 3 = 2520$$

29. The number of ice cream cones possible is equal to the number of permutations possible with 3 elements in all with each permutation having all the three elements.

This is given by: ${}_3P_3 = 3! = 3 \cdot 2 \cdot 1 = 6$

The total number of cones possible is 6.

The number of permutations in which the Superman is on top is equal to 2. This gives the probability that a random ice cream cone has Superman on top as $\frac{2}{6} = \frac{1}{3}$

The probability that Superman will be on top is 1/3

30. There are 4 jacks in a standard deck of 52 cards.

The chance of drawing a jack the first time is $\frac{4}{52}$

If you draw a jack and the card is not replaced, there are now 3 jacks in a deck of 51.

So the chance of drawing a jack the second time is $\frac{3}{51}$.

The probability of two events occurring is equal to the product of the individual events. Therefore:

$$\frac{4}{52} \cdot \frac{3}{51} = \frac{12}{2652} = \frac{1}{221} \approx 0.452\%$$

31.

(a) If the town cannot host a Super Bowl two consecutive years, use the following permutation:

$${}_n P_k = \frac{n!}{(n-k)!}$$

If the town cannot repeat a Super Bowl two consecutive years, then...

$n = 9$ (the number of events, in this case, the number of towns)

$k = 2$ (the number of sequences without repetition)

$${}_9 P_2 = \frac{9!}{(9-2)!} = \frac{9!}{7!} = \frac{362,880}{5,040} = 72$$

(b) If the town can host a Super Bowl two consecutive years, you do not use a permutation because a permutation requires non-repetition. If you have m ways to make the first choice and n ways to make the second choice, then you have $m \cdot n$ ways to make both choices.

$$m = 9$$

$$n = 9$$

$$m \cdot n = 9 \cdot 9 = 81$$

Mixed Review

$$32. \begin{cases} 2x - 3y > -9 \\ y < 1 \end{cases}$$

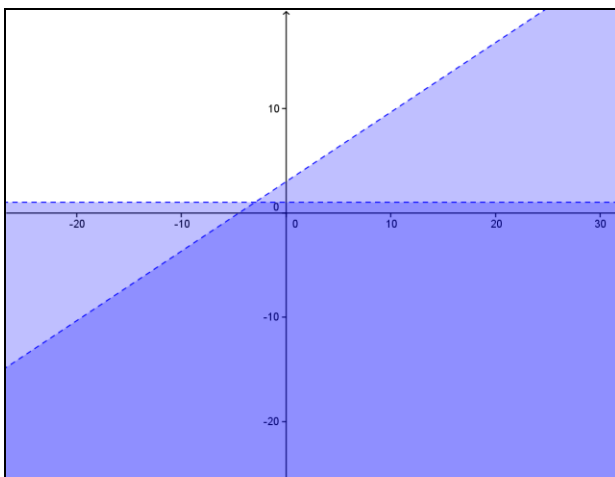

33.

There are about 3.28 feet in a meter.

$$24 * 3.28 \approx 78.72 \text{ feet.}$$

There are 60 seconds in a minute.

$$1 * 60 = 60 \text{ seconds.}$$

$$\approx 78.72 \text{ feet} / 60 \text{ seconds}$$

Divide $78.72 \div 60$

$$\approx 1.312 \text{ feet / second}$$

34. The absolute value can never be a negative number so this can never be true. There is no solution.

$$35. 6.16 - (-9.86) = 16.02$$

36. Which of the following vertices provides the minimum cost according to the equation $2x + 20y = \text{cost}$: $(3,6)$ $(9,0)$ $(6,2)$ $(0,11)$

$$2x + 20y = \text{cost}$$

$$2x + 20y = \text{cost}$$

$$2x + 20y = \text{cost}$$

$$2x + 20y = \text{cost}$$

$$2(3) + 20(6) = \text{cost}$$

$$2(9) + 20(0) = \text{cost}$$

$$2(6) + 20(2) = \text{cost}$$

$$2(0) + 20(11) = \text{cost}$$

$$6 + 120 = \text{cost}$$

$$18 + 0 = \text{cost}$$

$$12 + 40 = \text{cost}$$

$$0 + 220 = \text{cost}$$

$$\text{cost} = 126$$

$$\text{cost} = 18$$

$$\text{cost} = 52$$

$$\text{cost} = 220$$

The point that provides the minimum cost is $(9,0)$ with the cost being 18.

37.

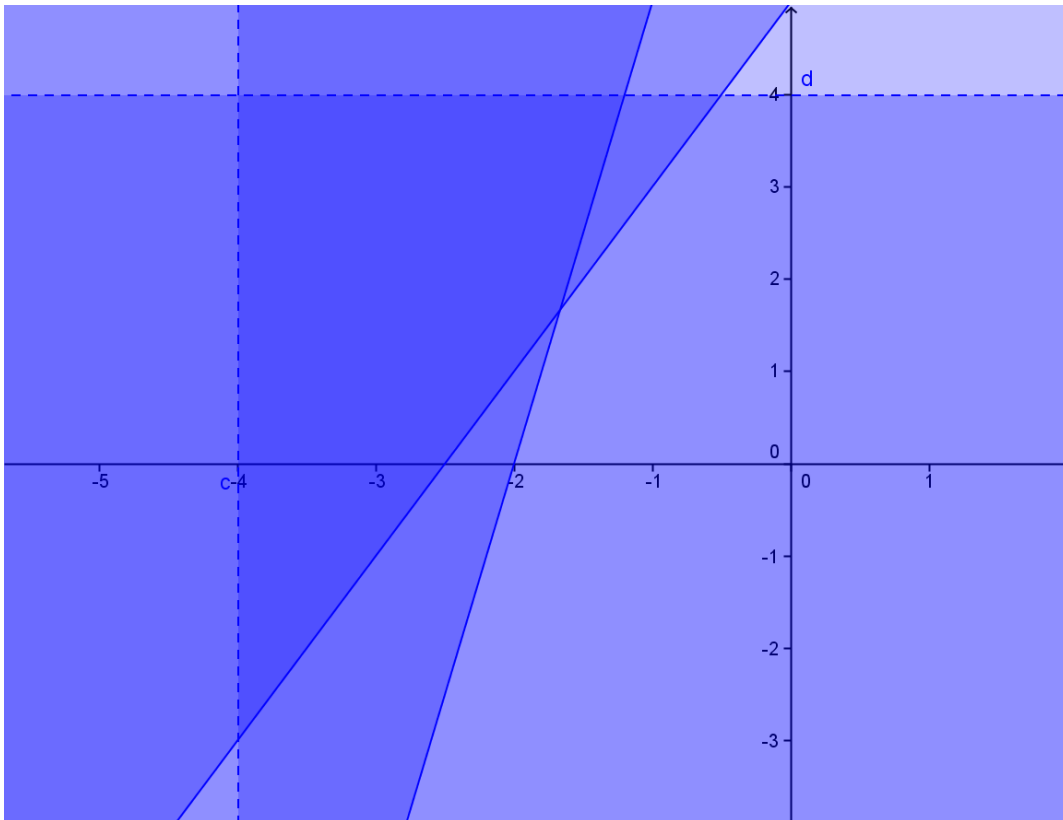

$$y \geq 5x + 10$$

$$y \geq 2x + 5$$

$$x > -4$$

$$y < 4$$

Lesson 7.8

Probability and Combinations

1. A combination is an arrangement of objects in no particular order. It is different from a permutation because in a permutation the order of the objects is essential to finding the correct solution.

2. The number of ways you can choose k objects from n possibilities is ${}_n C_k = \frac{n!}{k!(n-k)!}$

3. ${}_3 C_9$ is impossible to evaluate because we would have to work with a factorial of a negative number. Factorials of negative numbers are undefined.

$$4. \binom{12}{2} = {}_{12} C_2 = \frac{12!}{2!(12-2)!} = 66$$

$$5. \binom{8}{5} = {}_8 C_5 = \frac{8!}{5!(8-5)!} = 56$$

$$6. \binom{5}{1} = {}_5 C_1 = \frac{5!}{1!(5-1)!} = 5$$

$$7. \binom{3}{0} = {}_3 C_0 = \frac{3!}{0!(3-0)!} = 1$$

$$8. \binom{9}{9} = {}_9 C_9 = \frac{9!}{9!(9-9)!} = 1$$

$$9. \binom{9}{4} = {}_9 C_4 = \frac{9!}{4!(9-4)!} = 126$$

$$10. \binom{20}{10} = {}_{20} C_{10} = \frac{20!}{10!(20-10)!} = 184756$$

$$11. \binom{19}{18} = {}_{19} C_{18} = \frac{19!}{18!(19-18)!} = 19$$

$$12. \binom{20}{14} = {}_{20}C_{14} = \frac{20!}{14!(20-14)!} = 3876$$

$$13. \binom{13}{9} = {}_{13}C_9 = \frac{13!}{9!(13-9)!} = 715$$

$$14. {}_7C_3 = \frac{7!}{3!(7-3)!} = 35$$

$$15. {}_{11}C_5 = \frac{11!}{5!(11-5)!} = 462$$

$$16. {}_5C_4 = \frac{5!}{4!(5-4)!} = 5$$

$$17. {}_{13}C_9 = \frac{13!}{9!(13-9)!} = 715$$

$$18. {}_{20}C_5 = \frac{20!}{5!(20-5)!} = 15504$$

$$19. {}_{15}C_{15} = \frac{15!}{15!(15-15)!} = 1$$

$$20. \binom{6}{2} = {}_6C_2 = \frac{6!}{2!(6-2)!} = 15$$

21. (steak)! * (vegan)! * (seafood)!
 $4! * 2! * 1!$
 $4 * 3 * 2 * 1 * 2 * 1 * 1 = 48$
 48 ways to order dinner

$$22. {}_{10}C_4 = \frac{10!}{4!(10-4)!} = 210$$

$$23. {}_{28}C_2 = \frac{28!}{2!(28-2)!} = 378$$

24. (wins)! * (losses)! * (ties)!
 $8! * 4! * 2!$
 $8 * 7 * 6 * 5 * 4 * 3 * 2 * 1 * 4 * 3 * 2 * 1 * 2 * 1 = 1935360$

25.

There are ${}_6C_3$ ways for all three to be red.

There are ${}_{10}C_3$ total possible outcomes.

$$P = \frac{{}_6C_3}{{}_{10}C_3}$$

$${}_6C_3 = \frac{6!}{3!(6-3)!} = 20$$

$${}_{10}C_3 = \frac{10!}{3!(10-3)!} = 120$$

$$P = \frac{20}{120} = \frac{1}{6}$$

The probability of all three marbles being red is one out of six.

26.

P(red) = 6/10 because there are 6 out of 10 red marbles

P(red) = 5/9 because there are 5 out of 9 red marbles

P(blue) = 4/8 because there are 4 out of 8 blue marbles

The probability that all three will occur is the product of these individual probabilities.

$$6/10 * 5/9 * 4/8 = 120/720 = 1/6$$

The probability is 1/6.

27.

There are 100 Senators, therefore: ${}_{100}C_2 = \frac{100!}{2!(100-2)!} = 4950$

$$28. \quad {}_7C_4 = \frac{7!}{4!(7-4)!} = 35$$

29.

$${}_{15}C_{11} = \frac{15!}{11!(15-11)!} = \frac{1307674368000}{958003200} = 1365$$

(The fact that they are true/false questions does not matter.)

30.

1. There are 7 total applicants and we are picking any two.

$${}^7C_2 = \frac{7!}{2!(7-2)!} = \frac{5040}{240} = 21$$

2. There are 4 women applicants and we are picking any two.

The first position has 4 women to choose from and the second position has 3 women to choose from, therefore: $4 * 3 = 12$

3. We are picking one man and one woman

The first position has 4 women to choose from and the second position has 3 men to choose from, therefore: $4 * 3 = 12$

Mixed Review

31. $15! = 15 * 14 * 13 * 12 * 11 * 10 * 9 * 8 * 7 * 6 * 5 * 4 * 3 * 2 * 1 = 1307674368000$

32. You can divide. When you divide the numerator by the denominator you can cancel out all the number in each factorial that are the same. So in this case the numbers 1 through 297 appear on both the top and the bottom. If we cancel all these out, we are left

with: $\frac{300 * 299 * 298}{1} = 300 * 299 * 298 = 26730600$

33.

There are 6 total outcomes on the die. Three of them are multiples of two.

$$P = \frac{{}_3C_1}{{}_6C_1} = \frac{3}{6} = \frac{1}{2}$$

The probability that the number rolled will be a multiple of 2 is one half or one out of 2.

34.

Let the number be x and y .

If the sum of the two numbers is 70.6, then: $x+y=70.6$

If the first number is one less than twice the second number, then: $x=2y-1$

Now let's solve the system using substitution.

$$\begin{cases} x + y = 70.6 \\ x = 2y - 1 \end{cases}$$

$$x + y = 70.6$$

$$(2y - 1) + y = 70.6$$

$$2y - 1 + y = 70.6$$

$$3y - 1 = 70.6$$

$$3y = 71.6$$

$$y \approx 23.8667$$

$$x = 2y - 1$$

$$x = 2(23.8667) - 1$$

$$x = 47.7334 - 1$$

$$x \approx 46.7334$$

Lesson 7.9
Chapter 7 Review

1. combination-an arrangement of objects in which order does not matter consistent-dependent system-a system with an infinite amount of solutions constraints-restrictions imposed by time, materials, or money feasible region-a solution set to system of inequalities inconsistent system-a system with no solutions linear programming-a method used by businesses to determine the most profitable or least cost given constraints permutation-an arrangement of objects when order matters system-two or more algebraic systems joined by the word and

2. The solutions to a system are located on the graph where the lines for all the equations intersect.

3. If one equation of a system is in slope-intercept form ($y=mx+b$) and the other is in standard form ($ax+by=c$) the most effective way to solve the system is to use substitution (put $mx+b$ in for y in the second equation). This is the most effective because it doesn't require any extra work to change the equations to able to work with them. You can solve the system just as it is.

$$4. \begin{cases} 7x - 4y = 11 \\ x + 2y = -19 \end{cases} (-3, -8)$$

$$7x - 4y = 11$$

$$x + 2y = -19$$

$$7(-3) - 4(-8) = 11$$

$$-3 + 2(-8) = -19$$

$$-21 + 32 = 11$$

$$-3 - 16 = -19$$

$$11 = 11$$

$$-19 = -19$$

Yes $(-3, -8)$ is a solution to this system.

$$5. \begin{cases} y = 0 \\ 8x + 7y = 8 \end{cases} (-1, 0)$$

$$8x + 7y = 8$$

$$8(-1) + 7(0) = 8$$

$$y = 0$$

$$-8 + 0 = 8$$

$$0 = 0$$

$$-8 \neq 8$$

No $(-1, 0)$ is not a solution to this system.

$$6. \begin{cases} y = -2 \\ y = -6x + 1 \end{cases}$$

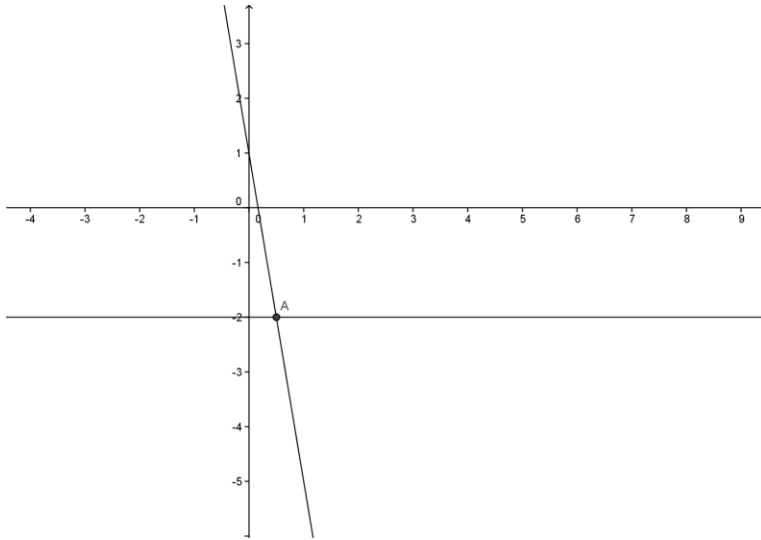

(0.5, -2)

$$7. \begin{cases} y = 3 - \frac{1}{3}x \\ x + 3y = 4 \end{cases}$$

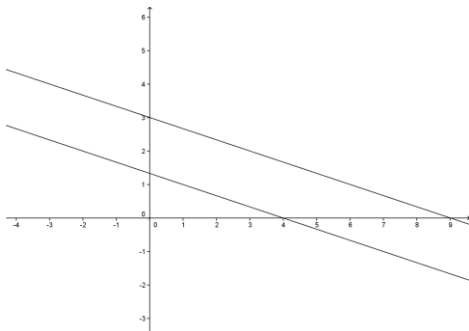

This system is inconsistent, it has no solutions (the lines are parallel).

$$8. \begin{cases} y = \frac{1}{2}x - 6 \\ 4y = 2x - 24 \end{cases}$$

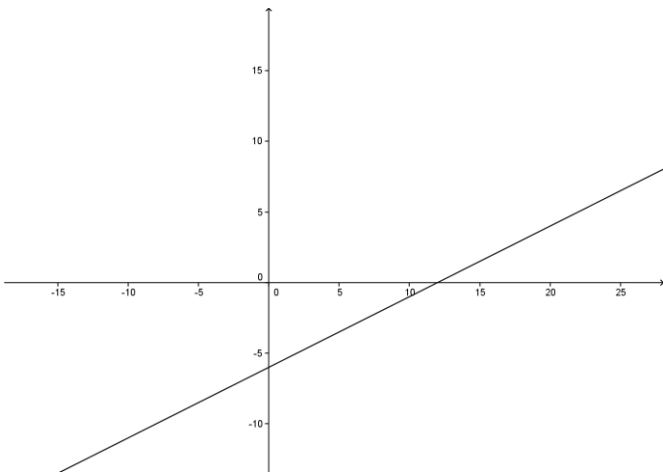

These lines are consistent-dependent. There are an infinite number of solutions.

$$9. \begin{cases} y = -\frac{4}{5}x + 7 \\ y = \frac{2}{5}x + 1 \end{cases}$$

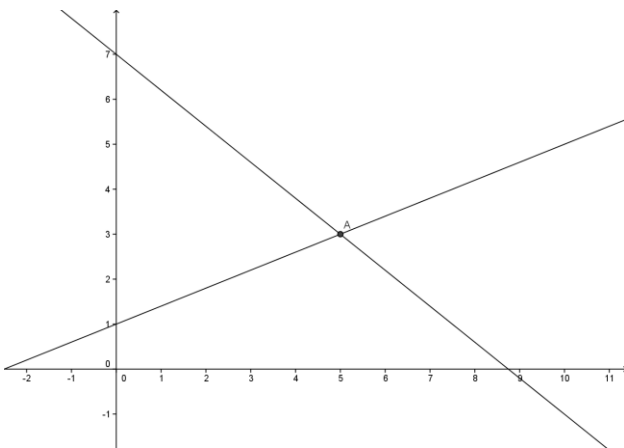

(5,3)

$$10. \begin{cases} x = 2 \\ y = 4 \\ y = \frac{1}{2}x + 3 \end{cases}$$

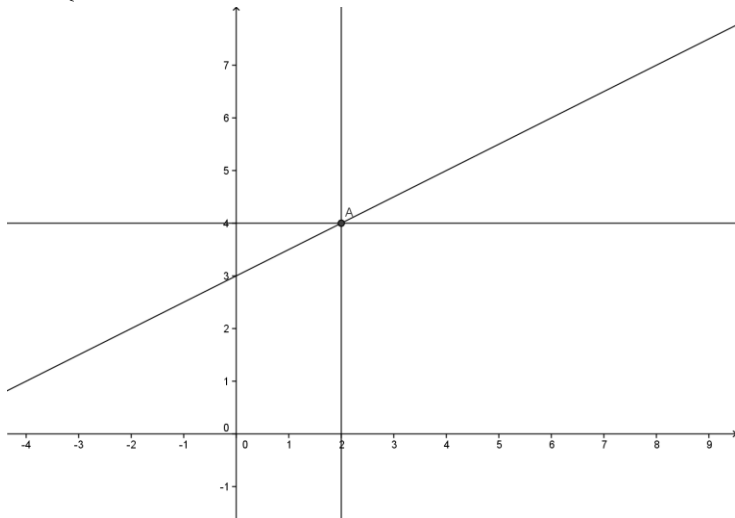

(2,4)

$$11. \begin{cases} y = 2x - 7 \\ y + 7 = 4x \end{cases}$$

$$y + 7 = 4x$$

$$(2x - 7) + 7 = 4x$$

$$2x - 7 + 7 = 4x$$

$$2x = 4x$$

$$-2x = 0$$

$$x = 0$$

$$y = 2x - 7$$

$$y = 2(0) - 7$$

$$y = 0 - 7$$

$$y = -7$$

Check

$$y = 2x - 7$$

$$-7 = 2(0) - 7$$

$$-7 = 0 - 7$$

$$-7 = -7$$

$$y + 7 = 4x$$

$$-7 + 7 = 4(0)$$

$$0 = 0$$

$$12. \begin{cases} y = -3x + 22 \\ y = -2x + 16 \end{cases}$$

$$-3x + 22 = -2x + 16$$

$$-x + 22 = 16$$

$$-x = -6$$

$$x = 6$$

$$y = -3x + 22$$

$$y = -3(6) + 22$$

$$y = -18 + 22$$

$$y = 4$$

Check

$$y = -3x + 22$$

$$4 = -3(6) + 22$$

$$4 = -18 + 22$$

$$4 = 4$$

$$y = -2x + 16$$

$$4 = -2(6) + 16$$

$$4 = -12 + 16$$

$$4 = 4$$

$$13. \begin{cases} y = 3 - \frac{1}{3}x \\ x + 3y = 4 \end{cases}$$

$$x + 3y = 4$$

$$x + 3\left(3 - \frac{1}{3}x\right) = 4$$

$$x + 9 - x = 4$$

$$9 \neq 4$$

This system is inconsistent. It has no solutions. (The equations are parallel lines.)

$$14. \begin{cases} 2x + y = -10 \\ y = x + 14 \end{cases}$$

$$2x + y = -10$$

$$2x + (x + 14) = -10$$

$$2x + x + 14 = -10$$

$$3x + 14 = -10$$

$$3x = -24$$

$$x = -8$$

$$y = x + 14$$

$$y = (-8) + 14$$

$$y = 6$$

Check

$$2x + y = -10$$

$$2(-8) + 6 = -10$$

$$-16 + 6 = -10$$

$$-10 = -10$$

$$y = x + 14$$

$$6 = -8 + 14$$

$$6 = 6$$

$$15. \begin{cases} y+19=-7x \\ y=-2x-9 \end{cases}$$

$$y+19=-7x$$

$$(-2x-9)+19=-7x$$

$$-2x-9+19=-7x$$

$$-2x+10=-7x$$

$$5x=-10$$

$$x=-2$$

$$y=-2x-9$$

$$y=-2(-2)-9$$

$$y=4-9$$

$$y=-5$$

Check

$$y+19=-7x$$

$$-5+19=-7(-2)$$

$$14=14$$

$$y=-2x-9$$

$$-5=-2(-2)-9$$

$$-5=4-9$$

$$-5=-5$$

$$16. \begin{cases} y=0 \\ 5x=15 \end{cases}$$

$$5x=15$$

$$x=3$$

The solution to the system is $x=3$ and $y=0$.

$$17. \begin{cases} y = 2x + 5 \\ y = \frac{1}{2}x + 2 \end{cases}$$

$$2x + 5 = \frac{1}{2}x + 2$$

$$2x = \frac{1}{2}x - 3$$

$$\frac{3}{2}x = -3$$

$$x = -\frac{3}{1} \div \frac{3}{2}$$

$$x = -\frac{3}{1} \times \frac{2}{3} = -2$$

$$x = -2$$

$$y = 2x + 5$$

$$y = 2(-2) + 5$$

$$y = -4 + 5$$

$$y = 1$$

Check

$$y = 2x + 5$$

$$1 = 2(-2) + 5$$

$$1 = -4 + 5$$

$$1 = 1$$

$$y = \frac{1}{2}x + 2$$

$$1 = \frac{1}{2}(-2) + 2$$

$$1 = -1 + 2$$

$$1 = 1$$

$$18. \begin{cases} 7x + 3y = 3 \\ y = 8 \end{cases}$$

$$7x + 3y = 3$$

$$7x + 3(8) = 3$$

$$7x + 24 = 3$$

$$7x = -21$$

$$x = -3$$

$$y = 8$$

Check

$$7x + 3y = 3$$

$$7(-3) + 3(8) = 3$$

$$-21 + 24 = 3$$

$$3 = 3$$

$$19. \begin{cases} 2x + 4y = -14 \\ -2x + 4y = 8 \end{cases}$$

$$2x + 4y = -14$$

$$\underline{-2x + 4y = 8}$$

$$0x + 8y = -6$$

$$8y = -6$$

$$y = -\frac{6}{8} = -\frac{3}{4} = -0.75$$

$$2x + 4y = -14$$

$$2x + 4\left(-\frac{3}{4}\right) = -14$$

$$2x - 3 = -14$$

$$2x = -11$$

$$x = -\frac{11}{2} = -5\frac{1}{2} = -5.5$$

Check

$$2x + 4y = -14$$

$$2\left(-\frac{11}{2}\right) + 4\left(-\frac{3}{4}\right) = -14$$

$$-11 - 3 = -14$$

$$-14 = -14$$

$$-2x + 4y = 8$$

$$-2\left(-\frac{11}{2}\right) + 4\left(-\frac{3}{4}\right) = 8$$

$$11 - 3 = 8$$

$$8 = 8$$

$$20. \begin{cases} 6x - 9y = 27 \\ 6x - 8y = 24 \end{cases}$$

$$\begin{array}{r} 6x - 9y = 27 \\ -6x + 8y = 24 \\ \hline 0x - y = 3 \\ -y = 3 \\ y = -3 \end{array}$$

$$\begin{array}{r} 6x - 9y = 27 \\ 6x - 9(-3) = 27 \\ 6x + 27 = 27 \\ 6x = 0 \\ x = 0 \end{array}$$

Check

$$\begin{array}{r} 6x - 9y = 27 \\ 6(0) - 9(-3) = 27 \\ 0 + 27 = 27 \\ 27 = 27 \end{array}$$

$$\begin{array}{r} 6x - 8y = 24 \\ 6(0) - 8(-3) = 24 \\ 0 + 24 = 24 \\ 24 = 24 \end{array}$$

$$21. \begin{cases} 3x - 2y = 0 \\ 2y - 3x = 0 \end{cases}$$

$$2y - 3x = 0 \rightarrow -3x + 2y = 0$$

$$3x - 2y = 0$$

$$\underline{-3x + 2y = 0}$$

$$0x + 0y = 0$$

$$0 = 0$$

This system is consistent dependent. There are an infinite number of solutions.

$$22. \begin{cases} 4x + 3y = 2 \\ -8x + 3y = 14 \end{cases}$$

$$-8x + 3y = 14$$

$$\underline{-4x - 3y = 2}$$

$$-12x + 0y = 12$$

$$-12x = 12$$

$$x = -1$$

$$4x + 3y = 2$$

$$4(-1) + 3y = 2$$

$$-4 + 3y = 2$$

$$3y = 6$$

$$y = 2$$

Check

$$4x + 3y = 2$$

$$4(-1) + 3(2) = 2$$

$$-4 + 6 = 2$$

$$2 = 2$$

$$-8x + 3y = 14$$

$$-8(-1) + 3(2) = 14$$

$$8 + 6 = 14$$

$$14 = 14$$

$$23. \begin{cases} -8x + 8y = 8 \\ 6x + y = 1 \end{cases}$$

$$\cancel{-8(6x + y = 1)} \rightarrow \cancel{-48x - 8y = -8}$$

$$-48x - 8y = -8$$

$$\underline{-8x + 8y = 8}$$

$$-56x = 0$$

$$x = 0$$

$$-8x + 8y = 8$$

$$-8(0) + 8y = 8$$

$$0 + 8y = 8$$

$$8y = 8$$

$$y = 1$$

Check

$$-8x + 8y = 8$$

$$-8(0) + 8(1) = 8$$

$$0 + 8 = 8$$

$$8 = 8$$

$$6x + y = 1$$

$$6(0) + 1 = 1$$

$$0 + 1 = 1$$

$$1 = 1$$

$$24. \begin{cases} 7x - 4y = 11 \\ x + 2y = -19 \end{cases}$$

$$\cancel{2(x+2y=-19)} \rightarrow \cancel{2x+4y=-38}$$

$$7x - 4y = 11$$

$$\underline{2x + 4y = -38}$$

$$9x + 0y = -27$$

$$9x = -27$$

$$x = -3$$

$$7x - 4y = 11$$

$$7(-3) - 4y = 11$$

$$-21 - 4y = 11$$

$$-4y = 32$$

$$y = -8$$

Check

$$7x - 4y = 11$$

$$7(-3) - 4(-8) = 11$$

$$-21 + 32 = 11$$

$$11 = 11$$

$$x + 2y = -19$$

$$-3 + 2(-8) = -19$$

$$-3 - 16 = -19$$

$$-19 = -19$$

$$25. \begin{cases} y = -2x - 1 \\ 4x + 6y = 10 \end{cases}$$

$$y = -2x - 1 \rightarrow 2x + y = -1$$

$$-2(2x + y = -1) \rightarrow -4x - 2y = 2$$

$$4x + 6y = 10$$

$$\underline{-4x - 2y = 2}$$

$$0x + 4y = 12$$

$$4y = 12$$

$$y = 3$$

$$y = -2x - 1$$

$$3 = -2x - 1$$

$$4 = -2x$$

$$x = -2$$

Check

$$y = -2x - 1$$

$$3 = -2(-2) - 1$$

$$3 = 4 - 1$$

$$3 = 3$$

$$4x + 6y = 10$$

$$4(-2) + 6(3) = 10$$

$$-8 + 18 = 10$$

$$10 = 10$$

$$26. \begin{cases} x - 6y = 20 \\ 2y - 3x = -12 \end{cases}$$

$$2y - 3x = -12 \rightarrow -3x + 2y = -12$$

$$3(x - 6y = 20) \rightarrow 3x - 18y = 60$$

$$3x - 18y = 60$$

$$\underline{-3x + 2y = -12}$$

$$0x - 16y = 48$$

$$-16y = 48$$

$$y = -3$$

$$x - 6y = 20$$

$$x - 6(-3) = 20$$

$$x + 18 = 20$$

$$x = 2$$

Check

$$x - 6y = 20$$

$$2 - 6(-3) = 20$$

$$2 + 18 = 20$$

$$20 = 20$$

$$2y - 3x = -12$$

$$2(-3) - 3(2) = -12$$

$$-6 - 6 = -12$$

$$-12 = -12$$

$$27. \begin{cases} -4x + 4y = 0 \\ 8x - 8y = 0 \end{cases}$$

$$\cancel{2(-4x + 4y = 0)} \rightarrow 8x + 8y = 0$$

$$-8x + 8y = 0$$

$$\underline{8x - 8y = 0}$$

$$0x + 0y = 0$$

$$0 = 0$$

This system is consistent-dependent. It has infinite solutions.

$$28. \begin{cases} -9x + 6y = -27 \\ -3x + 2y = -9 \end{cases}$$

$$\cancel{-3(-3x + 2y = -9)} \rightarrow 9x - 6y = 27$$

$$-9x + 6y = -27$$

$$\underline{9x - 6y = 27}$$

$$0x + 0y = 0$$

$$0 = 0$$

This system is consistent-dependent. It has infinite solutions.

$$29. \begin{cases} y > -\frac{3}{5}x - 5 \\ y \geq -2x + 2 \end{cases}$$

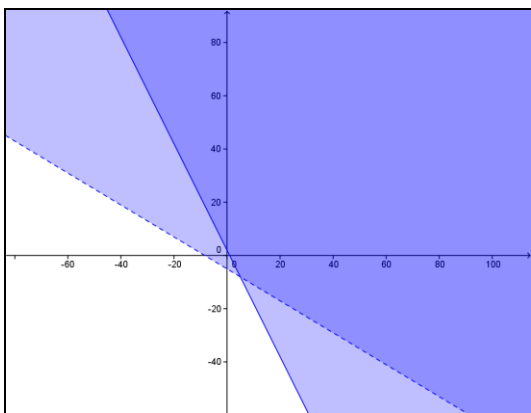

$$30. \begin{cases} y > \frac{13}{8}x + 8 \\ y \geq \frac{1}{4}x - 3 \end{cases}$$

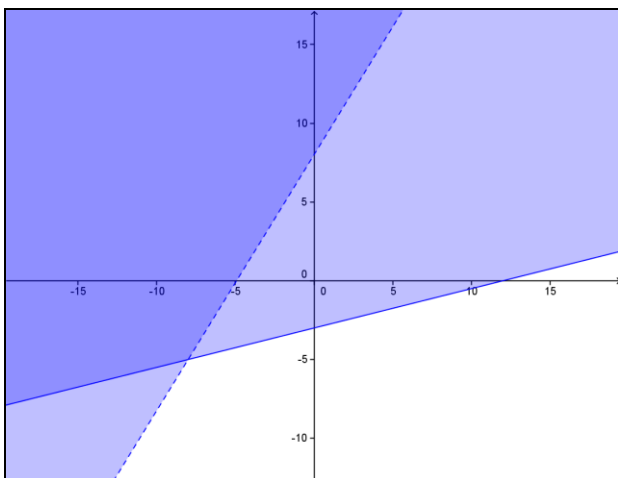

$$31. \begin{cases} y \leq \frac{3}{5}x - 5 \\ y \geq -2x + 8 \end{cases}$$

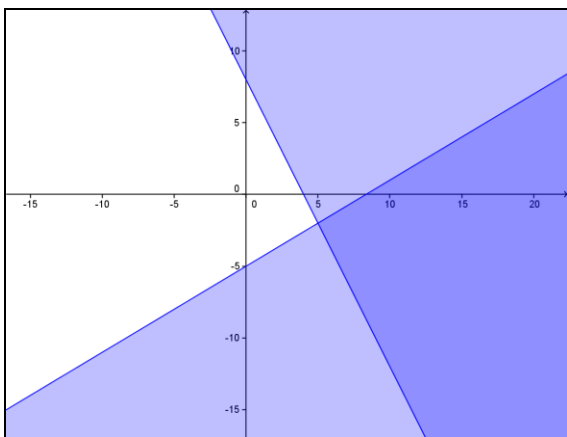

$$32. \begin{cases} y \leq -\frac{7}{5}x - 3 \\ y \geq \frac{4}{5}x + 4 \end{cases}$$

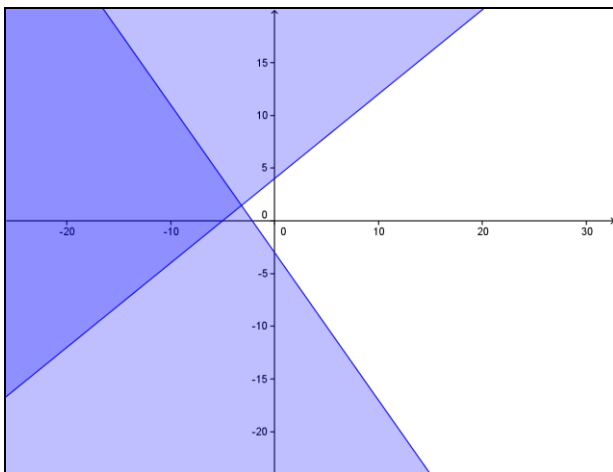

$$33. \begin{cases} x < 5 \\ y \geq \frac{9}{5}x - 2 \end{cases}$$

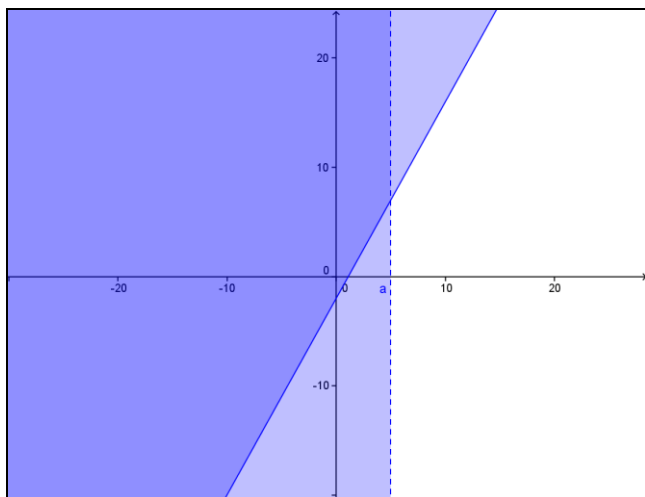

34. Equation on the right side:

Let's use the slope intercept formula $\rightarrow y = mx + b$

y-intercept=(0,5)

b=5

Now let's find two points on the line so we can find the slope: (2,0) (0,5)

$$m = \frac{y_2 - y_1}{x_2 - x_1}$$

$$m = \frac{5 - 0}{0 - 2} = -\frac{5}{2} = -2.5$$

$$m = -2.5$$

If we look at the graph we can see that the shaded area is where y is less than or equal to the equation. Therefore: $y \leq -2.5x + 5$

Equation on the left side:

Let's use the slope intercept formula again $\rightarrow y = mx + b$

y-intercept=(0,-5)

b= -5

Now let's find two points on the line so we can find the slope: (0,-5) (-2,0)

$$m = \frac{y_2 - y_1}{x_2 - x_1}$$

$$m = \frac{0 - (-5)}{-2 - 0} = -\frac{5}{2} = -2.5$$

$$m = -2.5$$

If we look at the graph we can see that the shaded area is where y is greater than but not equal to the equation. Therefore: $y > -2.5x - 5$

The system is:
$$\begin{cases} y \leq -2.5x + 5 \\ y > -2.5x - 5 \end{cases}$$

35. Equation on the upper right side:

Let's use the slope intercept formula $\rightarrow y = mx + b$

y-intercept=(0,8)

b=8

Now let's find two points on the line so we can find the slope: (0,8) (5,4.5)

$$m = \frac{y_2 - y_1}{x_2 - x_1}$$

$$m = \frac{8 - 4.5}{0 - 5} = -\frac{3.5}{5} = -3.5 \div 5 = -0.7$$

$$m = -0.7$$

If we look at the graph we can see that the shaded area is where y is less than or equal to the equation. Therefore: $y \leq -0.7x + 8$

Equation on the lower right side:

Let's use the slope intercept formula again $\rightarrow y = mx + b$

y-intercept=(0,0)

b= 0

Now let's find two points on the line so we can find the slope: (0,0) (5,4.5)

$$m = \frac{y_2 - y_1}{x_2 - x_1}$$

$$m = \frac{4.5 - 0}{5 - 0} = \frac{4.5}{5} = 4.5 \div 5 = 0.9$$

$$m = 0.9$$

If we look at the graph we can see that the shaded area is where y is greater than but not equal to the equation. Therefore: $y > -0.9x + 0 \rightarrow y > -0.9x$

The system is also constrained by the y-axis which is $x \geq 0$

$$\text{The system is: } \begin{cases} y \leq -0.7x + 8 \\ y > 0.9x \\ x \geq 0 \end{cases}$$

36.

Let's say that x is the number of texts and y is the total cost.

Plan A is: $y = 39.99 + 0.08x$

Plan B is: $y = 69.99$

Now let's solve the system using substitution.

$$\begin{cases} y = 39.99 + 0.08x \\ y = 69.99 \end{cases}$$

$$69.99 = 39.99 + 0.08x$$

$$30 = 0.08x$$

$$x = 375$$

The two plans will charge the same at 375 texts.

My advice for Yolanda would be that if she uses more than 375 texts, she should get plan B, but if she uses less, she should get plan A.

37. Let's call the numbers x and y .

The difference of the two numbers is -21.3 , therefore: $x - y = -21.3$

The second number is 3 more than one half the first number, therefore: $y = \frac{1}{2}x + 3$

Now let's solve the system using substitution.

$$\begin{cases} x - y = -21.3 \\ y = \frac{1}{2}x + 3 \end{cases}$$

$$x - y = -21.3$$

$$x - \left(\frac{1}{2}x + 3\right) = -21.3$$

$$x - \frac{1}{2}x - 3 = -21.3$$

$$\frac{1}{2}x = -18.3$$

$$x = -36.6$$

$$y = \frac{1}{2}x + 3$$

$$y = \frac{1}{2}(-36.6) + 3$$

$$y = -18.3 + 3$$

$$y = -15.3$$

Check

$$x - y = -21.3$$

$$(-36.6) - (-15.3) = -21.3$$

$$-36.6 + 15.3 = -21.3$$

$$-21.3 = -21.3$$

$$y = \frac{1}{2}x + 3$$

$$(-15.3) = (.5)(-36.6) + 3$$

$$-15.3 = -18.3 + 3$$

$$-15.3 = -15.3$$

The first number is -36.6 and the second number is -15.3 .

38.

Let's call the cost of an apple pie A and the cost of a blueberry pie B .

If nine apple pies and six blueberry pies cost a total of \$126 then: $9A+6B=126$

If 12 apple pies and 12 blueberry cost a total of \$204 then: $12A+12B=204$

Now let's solve the system using multiplication and elimination.

$$\begin{cases} 9A + 6B = 126 \\ 12A + 12B = 204 \end{cases}$$

$$-2(9A + 6B = 126) \rightarrow -18A - 12B = -252$$

$$12A + 12B = 204$$

$$\underline{-18A - 12B = -252}$$

$$-6A + 0B = -48$$

$$-6A = -48$$

$$A = 8$$

$$12A + 12B = 204$$

$$12(8) + 12B = 204$$

$$96 + 12B = 204$$

$$12B = 108$$

$$B = 9$$

Check

$$9A + 6B = 126$$

$$9(8) + 6(9) = 126$$

$$72 + 54 = 126$$

$$126 = 126$$

$$12A + 12B = 204$$

$$12(8) + 12(9) = 204$$

$$96 + 108 = 204$$

$$204 = 204$$

The cost of one apple pie is \$8. The cost of two blueberry pies is $9(2) = \$18$.

39. Let's call the speed of the jet x and the speed of the wind y .

On the trip there, the jet is traveling with the help of the wind. Therefore: $7x+7y=784$

On the trip back, the jet is traveling against the wind. Therefore: $14x-14y=784$

Now let's solve the system using elimination.

$$\begin{cases} 7x+7y=784 \\ 14x-14y=784 \end{cases}$$

$$2(7x+7y=784) \rightarrow 14x+14y=1568$$

$$14x+14y=1568$$

$$\underline{14x-14y=784}$$

$$28x+0y=2352$$

$$28x=2352$$

$$x = \frac{2352}{28} = 84$$

$$7x+7y=784$$

$$7(84)+7y=784$$

$$588+7y=784$$

$$7y=196$$

$$y=28$$

Check

$$7x+7y=784$$

$$14x-14y=784$$

$$7(84)+7(28)=784 \quad 14(84)-14(28)=784$$

$$588+196=784 \quad 1176-392=784$$

$$784=784 \quad 784=784$$

The jet travels at approximately 84 miles per hour and the wind speed is approximately 28 miles per hour.

40.

Let's call the speed of the canoe x and the speed of the river y .

On the trip downstream the canoe travels for one hour and has the help of the river.

Therefore: $x + y = 7$

On the trip upstream the canoe travels for 10.5 hours and has to work against the river.

Therefore: $10.5x - 10.5y = 7$

Now let's solve the system using elimination.

$$\begin{cases} x + y = 7 \\ 10.5x - 10.5y = 7 \end{cases}$$

$$10.5(x + y = 7) \rightarrow 10.5x + 10.5y = 73.5$$

$$10.5x - 10.5y = 7$$

$$\underline{10.5x + 10.5y = 73.5}$$

$$21x + 0y = 80.5$$

$$21x = 80.5$$

$$x = 80.5 \div 21 = \frac{805}{10} \times \frac{1}{21} = \frac{115}{30} = \frac{23}{6}$$

$$x = \frac{23}{6} \approx 3.83$$

$$x + y = 7$$

$$\frac{23}{6} + y = 7$$

$$y = 7 - \frac{23}{6} = \frac{42}{6} - \frac{23}{6} = \frac{19}{6}$$

$$y = \frac{19}{6} \approx 3.167$$

The speed of the canoe is approximately 3.83 miles per hour and the speed of the river is approximately 3.167 miles per hour.

41. Let call the price of a student ticket S and the price of an adult ticket A .

On Saturday we have 120 times the price of student tickets plus 45 times the price of adult tickets which equals 1102.50. Therefore: $120S + 45A = 1102.50$

On Sunday we have 35 times the price of student tickets plus 80 times the price of adult tickets which equals 890. Therefore: $35S + 80A = 890$

Now let's solve the system using multiplication and elimination.

$$\begin{cases} 120S + 45A = 1102.50 \\ 35S + 80A = 890 \end{cases}$$

$$16(120S + 45A = 1102.50) \rightarrow 1920S + 720A = 17640$$

$$-9(35S + 80A = 890) \rightarrow -315S - 720A = -8010$$

$$1920S + 720A = 17640$$

$$\underline{-315S - 720A = -8010}$$

$$1605S + 0A = 9630$$

$$1605S = 9630$$

$$S = 6$$

$$35S + 80A = 890$$

$$35(6) + 80A = 890$$

$$210 + 80A = 890$$

$$80A = 680$$

$$A = 8.5$$

Student tickets cost \$6 and adult tickets cost \$8.50.

42.

1. Let's call the number of bracelets x and the number of necklaces y . Based on the information in the problem we can create an inequality that represents the constraint on beads and an inequality that represents the constraint on time. In addition Rihanna cannot make negative necklaces or bracelets so both x and y must be greater than or equal to 0.

$$\begin{cases} 36x + 80y \leq 600 \\ x + 3y \leq 20 \\ x \geq 0 \\ y \geq 0 \end{cases}$$

2.

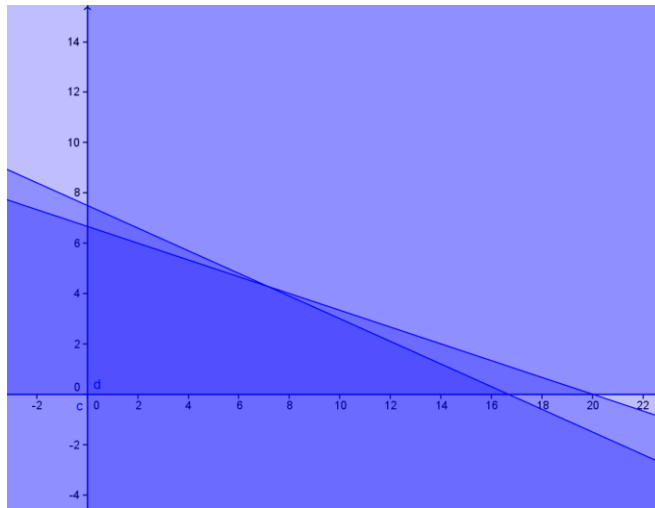

(0,0) (17,0) (7,5) (0,6.5)

3. Profit = $8x + 7y$

Looking at the vertices we can work out where Rihanna will make her maximum profit. We know it is not at (0,0) because if she makes zero pieces of jewelry, her profit will be zero.

Let's try out the rest.

$8x + 7y = P$	$8x + 7y = P$	$8x + 7y = P$
$8(17) + 7(0) = P$	$8(7) + 7(5) = P$	$8(0) + 7(6.5) = P$
$136 + 0 = P$	$56 + 35 = P$	$0 + 45.5 = P$
$P = 136$	$P = 91$	$P = 45.5$

Rihanna will make her maximum profit if she uses her beads and time to make 17 bracelets and 0 necklaces.

43.

1. Let's call the number of acres of soybeans x and the number of acres of wheat y . Based on the information we know the constraints on space and that the farmer has a requirement for the ratio of soybeans to wheat. In addition, it is impossible to plant negative crops so both x and y must be greater than or equal to zero.

$$\begin{cases} x + y \leq 65 \\ x \leq 2y \\ x \geq 0 \\ y \geq 0 \end{cases}$$

2.

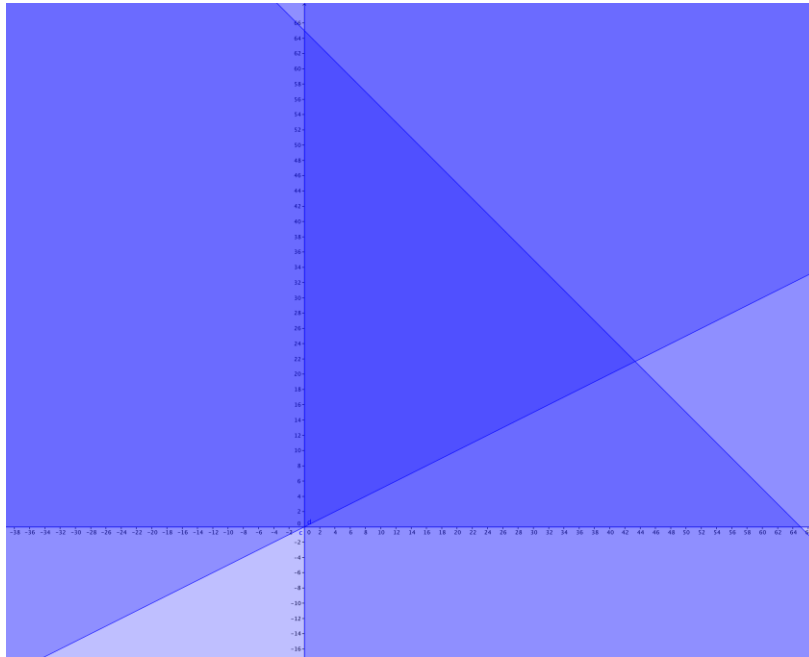

$$(0,0) (0,65) (43.333, 21.666)$$

3. To minimize the cost the farmer should plant no crops. Assuming he wants to plant something, he should plant 43.333 soybeans and 21.666 wheat. Since the crops cost the same thing, that information is unnecessary.

44. $10! = 10 \cdot 9 \cdot 8 \cdot 7 \cdot 6 \cdot 5 \cdot 4 \cdot 3 \cdot 2 \cdot 1 = 3628800$

45. $\cancel{5} \cdot \cancel{4} \cdot \cancel{3} \cdot 2 \cdot 1 = 12$

46. $\frac{100}{97} = 1009998 = 97020$

47.

Here is a visual way to do it. Imagine each blank is a player's position:

____ _ ____ _ kicker ____ _ ____ _

The kicker position is taken, the other 8 can fit into the other spaces.

Use a permutation of 8 instead of 9 because the kicker position is already taken.

$8! = 40,320$ arrangements

$$48. \quad {}_{15}C_1 = \frac{15!}{1!(15-1)!} = 15$$

$$49. \quad {}_{15}C_3 = \frac{15!}{3!(15-3)!} = 455$$

50. There are 6 teams (T1, T2, ..., T6)

$${}_6C_2 = \frac{6!}{2!(6-2)!} = 30$$

51. For the 1st, 2nd, 3rd, .. 6th places, the total number of combination is

$${}_6C_6 = 6! = 720$$

$$52. \quad \binom{14}{12} = {}_{14}C_{12} = \frac{14!}{12!(14-12)!} = 91$$

$$53. \quad \binom{8}{8} = {}_8C_8 = \frac{8!}{8!(8-8)!} = 1$$

This problem is a combination of eight items or choices chosen 8 at a time.

$$54. \quad {}_9C_4 = \frac{9!}{4!(9-4)!} = 126$$

55.

$$P = \frac{{}_6C_2}{{}_{11}C_2}$$

$${}_6C_2 = \frac{6!}{2!(6-2)!} = \frac{720}{48} = 15$$

$${}_{11}C_2 = \frac{11!}{2!(11-2)!} = \frac{39916800}{725760} = 55$$

$$P = \frac{15}{55} = \frac{3}{11}$$

The probability that both marbles will be green is 3 out of 11.

56.

$$\text{Teachers} = {}_{22}C_4 = \frac{22!}{4!(22-4)!} = 7315$$

$$\text{Students} = {}_{200}C_6 = \frac{200!}{6!(200-6)!} = 82408626300$$

$$\text{Total} = C(\text{teachers}) * C(\text{students}) = 7315 * 82408626300 = 602819101384500$$

There are 602,819,101,384,500 possible committees.

Lesson 7.10
Chapter 7 Test

1. *False* $\binom{n}{k}$ is a shorter way to write a combination, NOT a permutation.

$$2. \begin{cases} y = \frac{1}{17}x + 18 \\ y = -\frac{21}{17}x - 4 \end{cases} \quad (-17, 17)$$

$$y = \frac{1}{17}x + 18$$

$$(17) = \frac{1}{17}(-17) + 18$$

$$17 = -1 + 18$$

$$17 = 17$$

Yes $(-17, 17)$ is a solution to the system.

$$y = -\frac{21}{17}x - 4$$

$$(17) = -\frac{21}{17}(-17) - 4$$

$$17 = 21 - 4$$

$$17 = 17$$

3. *The primary difference between a combination and a permutation* is that the order of the items chosen is essential to a permutation, while the order makes no difference in a combination.

4. Let's call the plane's speed x and the wind speed y .

Traveling against the wind the trip took 12.5 hours, therefore: $12.5x - 12.5y = 1150$

Traveling with the wind the trip took 11 hours, therefore: $11x + 11y = 1150$

Now let's solve the system using multiplication and elimination.

$$\begin{cases} 12.5x - 12.5y = 1150 \\ 11x + 11y = 1150 \end{cases}$$

$$11(12.5x - 12.5y = 1150) \rightarrow 137.5x - 137.5y = 12650$$

$$12.5(11x + 11y = 1150) \rightarrow 137.5x + 137.5y = 14375$$

$$137.5x - 137.5y = 12650$$

$$137.5x + 137.5y = 14375$$

$$\hline 275x + 0y = 27025$$

$$275x = 27025$$

$$x \approx 98.27$$

$$11x + 11y = 1150$$

$$11(98.27) + 11y = 1150$$

$$1080.97 + 11y = 1150$$

$$11y = 69.03$$

$$y \approx 6.2755$$

The speed of the plane is approximately 98.27 miles per hour. The speed of the wind is approximately 6.2755 miles per hour.

5. *If a solution set to a system of inequalities has two dashed boundary lines then you can conclude that the coordinates on the boundaries are NOT included in the solution to the system.*

6. In order for the system to be consistent-dependent, the equations have to be equal. They must have the same slope and y-intercept. Let's change the first equation into point-slope form.

$$5x + 2y = 20$$

$$2y = 20 - 5x$$

$$2y = -5x + 20$$

$$y = -\frac{5}{2}x + 10$$

Now let's do the same with the second equation.

$$15x + ky = 60$$

$$ky = 60 - 15x$$

$$ky = -15x + 60$$

$$y = -\frac{15}{k}x + \frac{60}{k}$$

Now that both equations are in point-slope form, let's find k.

$$-\frac{15}{k} = -\frac{5}{2}$$

$$\frac{15}{k} = \frac{5}{2}$$

$$30 = 5k$$

$$k = 6$$

$$\frac{60}{k} = 10$$

$$10k = 60$$

$$k = 6$$

We can see that k must equal 6 so that both equations have the same slope and y-intercept to make the equations consistent-dependent.

7. Let's call Mother's Day arrangements x and Graduation arrangements y . Joy Lynn has constraints on the number of roses and the number of lilies. Each Mother's Day arrangement takes 8 roses, each Graduation arrangement takes 4 roses and the total must not equal more than 120, therefore: $8x + 4y \leq 120$
 Each Mother's Day arrangement takes 6 lilies, each Graduation arrangement takes 12 lilies and the total must not equal more than 162, therefore: $6x + 12y \leq 162$
 In addition, Joy Lynn cannot make negative arrangements so both x and y must be greater than or equal to zero.

The constraints are:

$$\begin{cases} 8x + 4y \leq 120 \\ 6x + 12y \leq 162 \\ x \geq 0 \\ y \geq 0 \end{cases}$$

Let's graph these to find the vertices.

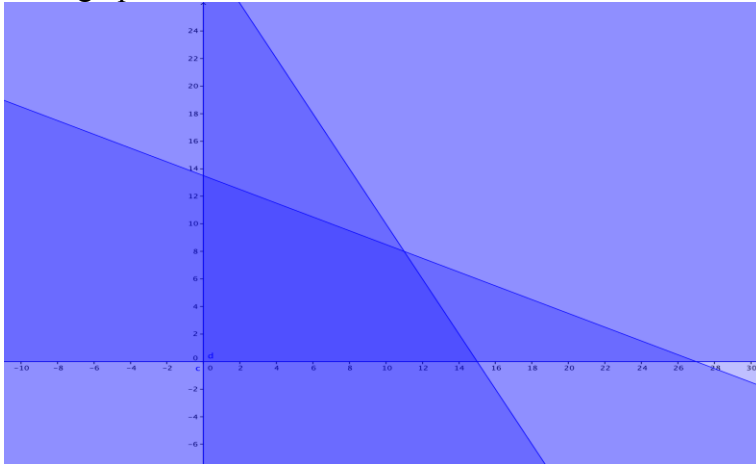

(0,0) (15,0) (11,8) (0,13.5)

The Maximum Revenue = $32.99x + 27.99y$. Let's substitute the vertices to find max R . (We know we can eliminate (0,0) because that will not produce any revenue. We can also eliminate the last point of intersection because we know that 13.5 of the product that produces \$27.99 each is not going to create more revenue than 15 of the product that produces 32.99 each.)

$$\begin{aligned} P &= 32.99x + 27.99y & P &= 32.99x + 27.99y \\ P &= 32.99(15) + 27.99(0) & P &= 32.99(11) + 27.99(8) \\ P &= 494.85 + 0 & P &= 362.89 + 223.92 \\ P &= 494.85 & P &= 586.81 \end{aligned}$$

To maximize revenue Joy Lynn should make 11 Mother's Day arrangements and 8 Graduation arrangements. Her maximum revenue will be \$586.81.

$$8. \begin{cases} -6x + y = -1 \\ -7x - 2y = 2 \end{cases}$$

$$-6x + y = -1 \rightarrow y = 6x - 1$$

$$-7x - 2y = 2$$

$$-7x - 2(6x - 1) = 2$$

$$-7x - 12x + 2 = 2$$

$$-19x = 0$$

$$x = 0$$

$$-6x + y = -1$$

$$-6(0) + y = -1$$

$$0 + y = -1$$

$$y = -1$$

Check

$$-6x + y = -1$$

$$-6(0) + (-1) = -1$$

$$0 - 1 = -1$$

$$-1 = -1$$

$$-7x - 2y = 2$$

$$-7(0) - 2(-1) = 2$$

$$0 + 2 = 2$$

$$2 = 2$$

$$9. \begin{cases} y = 0 \\ 8x + 7y = 8 \end{cases}$$

$$8x + 7y = 8$$

$$8x + 7(0) = 8$$

$$8x + 0 = 8$$

$$8x = 8$$

$$x = 1$$

$$y = 0$$

$$10. \begin{cases} y = x + 8 \\ y = 3x + 16 \end{cases}$$

$$x + 8 = 3x + 16$$

$$x - 3x = 16 - 8$$

$$-2x = 8$$

$$x = -4$$

$$y = x + 8$$

$$y = (-4) + 8$$

$$y = 4$$

Check

$$y = x + 8$$

$$4 = (-4) + 8$$

$$4 = 4$$

$$y = 3x + 16$$

$$4 = 3(-4) + 16$$

$$4 = -12 + 16$$

$$4 = 4$$

$$11. \begin{cases} y = -2x - 2 \\ y = -2x + 17 \end{cases}$$

$$-2x - 2 = -2x + 17$$

$$-2x + 2x = 17 + 2$$

$$0 \neq 19$$

This system is inconsistent. It has NO solutions. (The equations are parallel lines.)

12.

1. There are 7 letters in the word violent, so all the letter can be pulled from the bag 7!

$$7! = 7*6*5*4*3*2*1=5040$$

2. There are 4 consonants in the word violent. $6!*4= 6*5*4*3*2*1*4=2880$

$$P = \frac{2880}{5040} = \frac{4}{7}$$

The probability that the last letter will be a consonant is 4 out of 7.

$$13. \quad {}_{12}C_5 = \frac{12!}{5!(12-5)!} = \frac{479001600}{604800} = 792$$

$$14. \quad 13! = 13*12*11*10*9*8*7*6*5*4*3*2*1=6227020800$$

Basic Algebra Flexbook Solution Key
Chapter 8
Exponents and Exponential Functions

Lesson 8.1
Exponential Properties Involving Products

1. Consider a^5 .
 1. The base is a .
 2. The exponent is 5.
 3. The power is a^5 .
 4. This power can be written using repeated multiplication as: $a*a*a*a*a$
2. negative
3. positive
4. negative
5. The difference between -5^2 and $(-5)^2$ is based on the order of operations, in the first expression you are squaring 5 (solving the exponent: 5^2) then making the answer negative. In the second expression you are squaring -5 , which results in a positive answer, because the exponent is an even number.
6. 2^2
7. $(-3)^3$
8. y^5
9. $(3a)^4$
10. 4^5
11. $(3x)^3$
12. $(-2a)^4$
13. $6^3x^2y^4$
14. 1
15. 0
16. 343

17. -36

18. 625

19. $3^4 * 3^7 = 3^{(4+7)} = 3^{11} = 177147$

20. $2^6 * 2 = 2^{(6+1)} = 2^7 = 128$

21. $(4^2)^3 = 4^{(2*3)} = 4^6 = 4096$

22. 64

23. 0.0001

24. -0.216

25. $6^3 * 6^6 = 6^{(3+6)} = 6^9 = 10077696$

26. $2^2 * 2^4 * 2^6 = 2^{(2+4+6)} = 2^{12} = 4096$

27. $3^2 * 4^3 = 9 * 64 = 576$

28. $x^2 * x^4 = x^{(2+4)} = x^6$

29. $x^2 * x^7 = x^{(2+7)} = x^9$

30. $(y^3)^5 = y^{(3*5)} = y^{15}$

31. $(-2y^4)(-3y) = -2 * -3 * y^4 * y = 6 * y^{(4+1)} = 6y^5$

32. $(4a^2)(-3a)(-5a^4) = 4 * -3 * -5 * a^2 * a * a^4 = 60 * a^{(2+1+4)} = 60a^7$

33. $(a^3)^4 = a^{(3*4)} = a^{12}$

34. $(xy)^2 = x^2y^2$

35. $(3a^2b^3)^4 = 3^4 * a^{(2*4)} * b^{(3*4)} = 81a^8b^{12}$

36. $(-2xy^4z^2)^5 = (-2)^5 * x^5 * y^{(4*5)} * z^{(2*5)} = -32x^5y^{20}z^{10}$

37. $(3x^2y^3) * (4xy^2) = 3 * 4 * x^2 * x * y^3 * y^2 = 12 * x^{(2+1)} * y^{(3+2)} = 12x^3y^5$

38. $(4xyz) * (x^2y^3) * (2yz^4) = 4 * 2 * x * x^2 * y * y^3 * y * z * z^4 = 8 * x^{(1+2)} * y^{(1+3+1)} * z^{(1+4)} = 8x^3y^5z^5$

$$39. (2a^3b^3)^2 = 2^2 * a^{(3*2)} * b^{(3*2)} = 4a^6b^6$$

$$40. (-8x)^3 (5x)^2 = (-8)^3 * 5^2 * x^3 * x^2 = -512 * 25 * x^{(3+2)} = -12800x^5$$

$$41. (4a^2) (-2a^3)^4 = 4 * (-2)^4 * a^2 * a^{(3*4)} = 4 * 16 * a^2 * a^{(12)} = 64 * a^{(2+12)} = 64a^{14}$$

$$42. (12xy) (12xy)^2 = (12xy)^3 = 12^3 * x^3 * y^3 = 1728x^3y^3$$

$$43. (2xy^2) (-x^2y)^2 (3x^2y^2) = 2 * -1^2 * 3 * x * x^{(2*2)} * x^2 * y^2 * y^2 * y^2 = 6 * x^{(1+4+2)} * y^{(2+2+2)} = 6x^7y^6$$

Mixed Review

44. How many ways can you choose a 4-person committee from seven people?

$${}^7C_4 = \frac{7!}{4!(7-4)!} = \frac{5040}{144} = 35$$

45. Three canoes cross a finish line to earn medals. Is this an example of a permutation or a combination? How many ways are possible?

This is a permutation.

The number of ways possible is $3!=6$

46. Find the slope between $(-9, 11)$ and $(18, 6)$

$$m = \frac{y_2 - y_1}{x_2 - x_1} = \frac{11 - 6}{-9 - 18} = -\frac{5}{27}$$

47. Name the set(s) to which $\sqrt{36}$ belongs.

When simplified $\sqrt{36} = \pm 6$. Therefore the expression belongs to Z (the integer set of numbers.) In addition, the integer set of numbers is also part of R (the real set of numbers).

The square root of 36 belongs to sets Z and R.

48. Simplify $\sqrt{74x^2}$

$$\sqrt{74x^2} \approx 8.6x$$

$$\sqrt{74x^2} = \sqrt{4} * \sqrt{18.5} * \sqrt{x^2} = 2x\sqrt{18.5}$$

49.

$$\frac{78}{x} = \frac{10}{100} = \frac{1}{10}$$

$$\frac{78}{x} = \frac{1}{10}$$

$$780 = x$$

50.

$$m = \frac{3-1}{5-3} = \frac{2}{2} = 1$$

$$y = mx + b$$

$$y = x + b$$

$$(5,3)$$

$$3 = 5 + b$$

$$b = -2$$

$$y = x - 2$$

Lesson 8.2
Exponential Properties Involving Quotients

$$1. \frac{5^6}{5^2} = 5^{6-2} = 5^4 = 625$$

$$2. \frac{6^7}{6^3} = 6^{7-3} = 6^4 = 1296$$

$$3. \frac{3^{10}}{3^4} = 3^{10-4} = 3^6 = 729$$

$$4. \left(\frac{2^2}{3^3}\right)^3 = \frac{2^{2 \cdot 3}}{3^{3 \cdot 3}} = \frac{2^6}{3^9} = \frac{64}{19683} = .003251536859$$

$$5. \frac{a^3}{a^2} = a^{3-2} = a$$

$$6. \frac{x^9}{x^5} = x^{9-5} = x^4$$

$$7. \frac{x^{10}}{x^5} = x^{10-5} = x^5$$

$$8. \frac{a^6}{a} = a^{6-1} = a^5$$

$$9. \frac{a^5 b^4}{a^3 b^2} = a^{5-3} \cdot b^{4-2} = a^2 b^2$$

$$10. \frac{4^5}{4^2} = 4^{5-2} = 4^3 = 64$$

$$11. \frac{5^7}{5^3} = 5^{7-3} = 5^4 = 625$$

$$12. \left(\frac{3^4}{5^2}\right)^2 = \frac{3^{4 \cdot 2}}{5^{2 \cdot 2}} = \frac{3^8}{5^4} = \frac{6561}{625} = 10.4976$$

$$13. \left(\frac{a^3 b^4}{a^2 b} \right)^3 = \frac{a^{3 \cdot 3} \times b^{4 \cdot 3}}{a^{2 \cdot 3} \times b^{1 \cdot 3}} = \frac{a^9 b^{12}}{a^6 b^3} = a^{9-6} \times b^{12-3} = a^3 b^9$$

$$14. \frac{x^6 y^5}{x^2 y^3} = x^{6-2} \times y^{5-3} = x^4 y^2$$

$$15. \left(\frac{6x^2 y^3}{2xy^2} \right) = 3 * x^{2-1} * y^{3-2} = 3xy$$

$$16. \left(\frac{8a^7 b^3}{2a^3 b} \right)^2 = \frac{8^2 * a^{7 \cdot 2} * b^{3 \cdot 2}}{2^2 * a^{3 \cdot 2} * b^2} = \frac{64a^{14} b^6}{4a^6 b^2} = 16a^{14-6} b^{6-2} = 16a^8 b^4$$

$$17. (x^2)^2 \cdot \frac{x^6}{x^4} = x^{2 \cdot 2} \cdot x^{6-4} = x^4 \cdot x^2 = x^{4+2} = x^6$$

$$18. \left(\frac{16a^6}{4b^5} \right)^3 \cdot \frac{b^{16}}{a^{16}} = \frac{16^3 a^{6 \cdot 3}}{4^3 b^{5 \cdot 3}} \cdot \frac{b^{16}}{a^{16}} = \frac{4096a^{18} b^{16}}{64a^{16} b^{15}} = 64a^2 b$$

$$19. \frac{6a^3}{2a^2} = 3a$$

$$20. \frac{15x^5}{5x} = 3x^4$$

$$21. \left(\frac{18a^{10}}{15a^4} \right)^4 = \frac{18^4 a^{10 \cdot 4}}{15^4 a^{4 \cdot 4}} = \frac{104976a^{40}}{50625a^{16}} = 2.0736a^{24}$$

$$22. \frac{25y^5 x^6}{20yx^2} = 1.25y^4 x^4$$

$$23. \left(\frac{x^6 y^4}{x^4 y^2} \right)^3 = \frac{x^{6 \cdot 3} y^{4 \cdot 3}}{x^{4 \cdot 3} y^{2 \cdot 3}} = \frac{x^{18} y^{12}}{x^{12} y^6} = x^{18-12} y^{12-6} = x^6 y^6$$

$$24. \left(\frac{6a^2}{4} \right)^2 \cdot \frac{5b}{3a} = \frac{6^2 a^{2 \cdot 2}}{4^2} \cdot \frac{5b}{3a} = \frac{36a^4 \cdot 5b}{16 \cdot 3a} = \frac{180a^4 b}{48a} = 3.75a^3 b$$

$$25. \frac{(3ab)^2(4a^3b^4)^3}{(6a^2b)^4} = \frac{3^2 \cdot a^2 \cdot b^2 \cdot 4^3 \cdot a^9 \cdot b^{12}}{6^4 a^8 b^4} = \frac{576a^{11}b^{14}}{1296a^8b^4} = .44\bar{a}^3b^{10}$$

$$26. \frac{(2a^2bc^2)(6abc^3)}{4ab^2c} = \frac{12a^3b^2c^5}{4ab^2c} = 3a^2c^4$$

Mixed Review

27.

$$x|z| - |z|$$

$$8|-4| - |-4|$$

$$(8)(4) - (4)$$

$$32 - 4$$

28

28. Graph the solution set to the system $\begin{cases} y < -x - 2 \\ y \geq -6x + 3 \end{cases}$

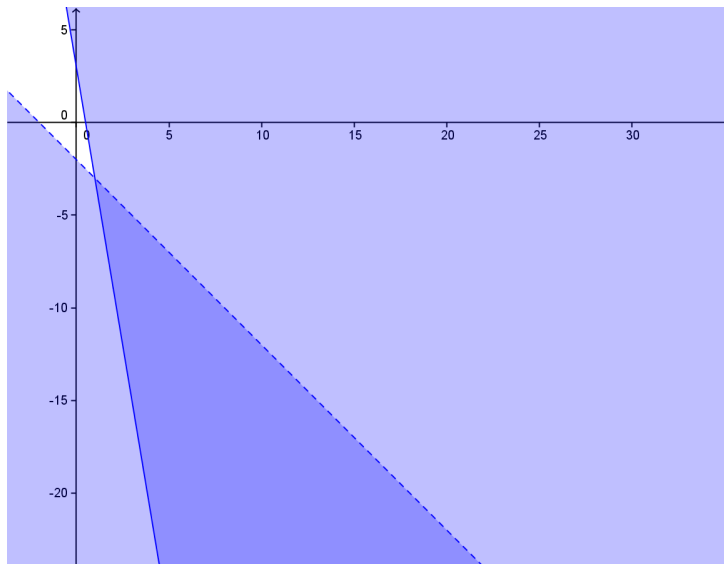

29. Evaluate $\binom{8}{4}$

$$\binom{8}{4} = {}_8C_4 = \frac{8!}{4!(8-4)!} = \frac{40320}{576} = 70$$

30. Answers will vary. It is correct as long as the situation involves 4 items or choices, being chosen one at a time, that can only be chosen once, so that the number of choices decreases by one with each pick.

31. $x^3 = 8$

Lesson 8.3

Zero, Negative, and Fractional Exponents

$$1. x^{-1} \cdot y^2 = \frac{1}{x} \cdot y^2 = \frac{y^2}{x}$$

$$2. x^{-4} = \frac{1}{x^4}$$

$$3. \frac{x^{-3}}{x^{-7}} = x^{-3-(-7)} = x^{-3+7} = x^4$$

$$4. x^{-1} = \frac{1}{x}$$

$$5. 2x^{-2} = 2 \cdot \frac{1}{x^2} = \frac{2}{x^2}$$

$$6. x^2 y^{-3} = x^2 \cdot \frac{1}{y^3} = \frac{x^2}{y^3}$$

$$7. 3x^{-1} y^{-1} = 3 \cdot \frac{1}{x} \cdot \frac{1}{y} = \frac{3}{xy}$$

$$8. 3x^{-3} = 3 \cdot \frac{1}{x^3} = \frac{3}{x^3}$$

$$9. a^2 b^{-3} c^{-1} = a^2 \cdot \frac{1}{b^3} \cdot \frac{1}{c} = \frac{a^2}{b^3 c}$$

$$10. 4x^{-1} y^3 = 4 \cdot \frac{1}{x} \cdot y^3 = \frac{4y^3}{x}$$

$$11. \frac{2x^{-2}}{y^{-3}} = 2 \cdot \frac{1}{x^2} \cdot y^3 = \frac{2y^3}{x^2}$$

$$12. a^{\frac{1}{2}} \cdot a^{\frac{1}{3}} = a^{\frac{1}{2} + \frac{1}{3}} = a^{\frac{3}{6} + \frac{2}{6}} = a^{\frac{5}{6}} = \sqrt[6]{a^5}$$

$$13. \left(a^{\frac{1}{3}}\right)^2 = a^{\frac{1}{3} \cdot 2} = a^{\frac{2}{3}} = \sqrt[3]{a^2}$$

$$14. \frac{a^{\frac{5}{2}}}{a^{\frac{1}{2}}} = a^{\frac{5}{2} - \frac{1}{2}} = a^{\frac{4}{2}} = a^2$$

$$15. \left(\frac{x^2}{y^3}\right)^{\frac{1}{3}} = (x^2 \cdot y^{-3})^{\frac{1}{3}} = x^{2 \cdot \frac{1}{3}} \cdot y^{-3 \cdot \frac{1}{3}} = x^{\frac{2}{3}} \cdot y^{-1} = \frac{x^{\frac{2}{3}}}{y} = \frac{\sqrt[3]{x^2}}{y}$$

$$16. \frac{x^{-3}y^{-5}}{z^{-7}} = \frac{1}{x^3} \cdot \frac{1}{y^5} \cdot z^7 = \frac{z^7}{x^3y^5}$$

$$17. \left(x^{\frac{1}{2}}y^{-\frac{2}{3}}\right)\left(x^2y^{\frac{1}{3}}\right) = x^{\frac{1}{2}+2} \cdot y^{-\frac{2}{3}+\frac{1}{3}} = x^{\frac{5}{2}} \cdot y^{-\frac{1}{3}} = \frac{x^{\frac{5}{2}}}{y^{\frac{1}{3}}} = \frac{x \cdot \sqrt{x}}{\sqrt[3]{y}}$$

$$18. \left(\frac{a}{b}\right)^{-2} = (a^{1-2} \cdot b^{-1-2}) = a^{-2}b^2 = \frac{1}{a^2} \cdot b^2 = \frac{b^2}{a^2}$$

$$19. (3a^{-2}b^2c^3)^3 = 3^3 \cdot a^{-2 \cdot 3} \cdot b^{2 \cdot 3} \cdot c^{3 \cdot 3} = 27 \cdot a^{-6} \cdot b^6 \cdot c^9 = \frac{27b^6c^9}{a^6}$$

$$20. x^{-3} \cdot x^3 = \frac{1}{x^3} \cdot x^3 = \frac{x^3}{x^3} = 1$$

$$21. \frac{a^{-3}(a^5)}{a^{-6}} = \frac{a^{-3+5}}{a^{-6}} = \frac{a^2}{a^{-6}} = a^{2-(-6)} = a^8$$

$$22. \frac{5x^6y^2}{x^8y} = 5 \cdot x^{6-8} \cdot y^{2-1} = 5x^{-2}y$$

$$23. \frac{(4ab^6)^3}{(ab)^5} = \frac{4^3 \cdot a^3 \cdot b^{6 \cdot 3}}{a^5b^5} = \frac{64a^3b^{18}}{a^5b^5} = 64a^{3-5}b^{18-5} = 64a^{-2}b^{13}$$

$$24. \left(\frac{3x}{y^{\frac{1}{3}}} \right)^3 = \frac{3^3 x^3}{y^{\frac{1}{3} \cdot 3}} = \frac{27x^3}{y} = 27x^3 y^{-1}$$

$$25. \frac{4a^2 b^3}{2a^5 b} = \left(\frac{4}{2} \right) \cdot a^{2-5} \cdot b^{3-1} = 2a^{-3} b^2$$

26.

$$\left(\frac{x}{3y^2} \right)^3 \cdot \frac{x^2 y}{4} = \frac{x^3}{3^3 y^{2 \cdot 3}} \cdot \frac{x^2 y}{4} = \frac{x^{3+2} y}{27 \cdot y^6 \cdot 4} = \frac{x^5 y}{108 y^6} = \frac{1}{108} \cdot x^5 \cdot y^{1-6} = \frac{1}{108} x^5 y^{-5} \approx .00925926 x^5 y^{-5}$$

$$27. \left(\frac{ab^{-2}}{b^3} \right)^2 = \frac{a^2 b^{-2 \cdot 2}}{b^{3 \cdot 2}} = \frac{a^2 b^{-4}}{b^6} = a^2 b^{-4-6} = a^2 b^{-10}$$

$$28. \frac{x^{-3} y^2}{x^2 y^{-2}} = x^{-3-2} y^{2-(-2)} = x^{-5} y^4$$

$$29. \frac{3x^2 y^{\frac{3}{2}}}{xy^{\frac{1}{2}}} = 3 \cdot x^{2-1} \cdot y^{\frac{3}{2} - \frac{1}{2}} = 3xy$$

$$30. \frac{(3x^3)(4x^4)}{(2y)^2} = \frac{12x^{3+4}}{2^2 y^2} = \frac{12x^7}{4y^2} = 3x^7 y^{-2}$$

$$31. \frac{a^{-2} b^{-3}}{c^{-1}} = a^{-2} b^{-3} c$$

$$32. \frac{x^{\frac{1}{2}} y^{\frac{5}{2}}}{x^{\frac{3}{2}} y^{\frac{3}{2}}} = x^{\frac{1}{2} - \frac{3}{2}} \cdot y^{\frac{5}{2} - \frac{3}{2}} = x^{-1} y$$

$$33. 3^{-2} = \frac{1}{3^2} = \frac{1}{9}$$

$$34. (6.2)^0 = 1$$

$$35. 8^{-4} \cdot 8^6 = 8^{-4+6} = 8^2 = 64$$

$$36. \left(16^{\frac{1}{2}}\right)^3 = 16^{\frac{1}{2} \cdot 3} = 16^{\frac{3}{2}} = \sqrt{16^3} = \sqrt{4096} = \pm 64$$

$$37. 5^0 = 1$$

$$38. 7^2 = 7 \cdot 7 = 49$$

$$39. \left(\frac{2}{3}\right)^3 = \frac{2^3}{3^3} = \frac{8}{27} \approx .2962963$$

$$40. 3^{-3} = \frac{1}{3^3} = \frac{1}{27} \approx .03703704$$

$$41. 16^{\frac{1}{2}} = \sqrt{16} = 4$$

$$42. 8^{-\frac{1}{3}} = \frac{1}{8^{\frac{1}{3}}} = \frac{1}{\sqrt[3]{8}} = \frac{1}{2} = 0.5$$

43.

$$2x^2 - 3y^3 + 4z$$

$$2(2^2) - 3(-1^3) + 4(3)$$

$$2(4) - 3(-1) + 12$$

$$8 + 3 + 12$$

$$11 + 12$$

$$23$$

44.

$$(x^2 - y^2)^2$$

$$(2^2 - (-1^2))^2$$

$$(4 - 1)^2$$

$$3^2$$

$$\underline{9}$$

45.

$$\left(\frac{3x^2y^5}{4z}\right)^{-2}$$
$$\left(\frac{3(2^2)(-1^5)}{4(3)}\right)^{-2} = \left(\frac{3(4)(-1)}{12}\right)^{-2} = \left(\frac{-12}{12}\right)^{-2} = (-1)^{-2} = -\frac{1}{1^2} = -1$$

46.

$$x^2 4x^3 y^4 4y^2$$
$$(2^2) \cdot 4 \cdot (2^3) \cdot (-1^4) \cdot 4 \cdot (-1^2)$$
$$4 \cdot 4 \cdot 8 \cdot 1 \cdot 4 \cdot 1$$
$$512$$

47.

$$a^4(b^2)^3 + 2ab$$
$$(-2^4)(1^2)^3 + 2(-2)(1)$$
$$(16)(1) + -4$$
$$16 - 4$$
$$12$$

48.

$$5x^2 - 2y^3 + 3z$$
$$5(3^2) - 2(2^3) + 3(4)$$
$$5(9) - 2(8) + 12$$
$$45 - 16 + 12$$
$$41$$

$$49. \left(\frac{a^2}{b^3}\right)^{-2} = \left(\frac{5^2}{3^3}\right)^{-2} = \left(\frac{25}{27}\right)^{-2} = \frac{25^{-2}}{27^{-2}} = \frac{27^2}{25^2} = \frac{729}{625} = 1.1664$$

50.

$$3 \cdot 5^5 - 10 \cdot 5 + 1$$

$$3 \cdot 3125 - 10 \cdot 5 + 1$$

$$9375 - 50 + 1$$

$$9325 + 1$$

$$9326$$

$$51. \frac{2 \cdot 4^2 - 3 \cdot 5^2}{3^2} = \frac{2 \cdot 16 - 3 \cdot 25}{9} = \frac{32 - 75}{9} = \frac{-43}{9} \approx -4.7777778$$

$$52. \left(\frac{3^3}{2^2}\right)^{-2} \cdot \frac{3}{4} = \frac{3^{-6}}{2^{-4}} \cdot \frac{3}{4} = \frac{2^4}{3^6} \cdot \frac{3}{4} = \frac{16}{729} \cdot \frac{3}{4} = \frac{4}{243} \approx .01646091$$

53.

When the test is answered each of the true/false questions can be answered in 2 ways. This allows them to be answered in 2^7 ways. The 3 multiple choice questions have 4 options and can be answered in 4^3 ways. $2^7 \cdot 4^3 = 128 \cdot 64 = 8192$. The test can be answered in 8192 ways.

54.

$$3a^4b^4 \cdot a^{-3}b^{-4}$$

$$3 \cdot a^{4+(-3)} \cdot b^{4+(-4)}$$

$$3a$$

55.

$$(x^4 y^2 \cdot xy^0)^5$$

$$(x^{4+1} \cdot y^{2+0})^5$$

$$(x^5 y^2)^5$$

$$x^{5 \cdot 5} y^{2 \cdot 5}$$

$$x^{25} y^{10}$$

$$56. \frac{v^2}{-vu^{-2} \cdot u^{-1}v^4} = \frac{v^2}{-v^{1+4} \cdot u^{-2+(-1)}} = \frac{v^2}{-v^5 u^{-3}} = \frac{v^2}{-v^5} \cdot \frac{1}{u^{-3}} = -v^{2-5} \cdot u^3 = -v^{-3} u^3 = \frac{u^3}{-v^3}$$

57.

$$-6(4n + 3) = n + 32$$

$$-24n - 18 = n + 32$$

$$-32 - 18 = 24n + n$$

$$-50 = 25n$$

$$n = -2$$

Check

$$-6(4n + 3) = n + 32$$

$$-6(4(-2) + 3) = -2 + 32$$

$$-6(-8 + 3) = 30$$

$$-6(-5) = 30$$

$$30 - 30$$

Lesson 8.4
Scientific Notation

1. 310.2

2. 74000

3. 0.00175

4. 0.000029

5. 0.00000000999

6. 2.784×10^{18}

7. 1.976×10^{-22}

8. 4.59×10^{-5}

9. 3.6782×10^{-4}

10. 1.3684×10^{15}

11. 0.62963×10^{18}

12. 1.2×10^5

13. 1.765244×10^6

14. 6.3×10

15. 9.654×10^3

16. 6.53937×10^8

17. 1×10^9

18. 1.2×10

19. 2.81×10^{-3}

20. 2.7×10^{-8}

21. 3×10^{-3}

22. 5.6×10^{-5}

23. 5.007×10^{-5}

24. 9.54×10^{-12}

25.

$$SA = 4\pi r^2$$

$$SA = 4(3.14)(1.08 \times 10^3)^2$$

$$SA = 4(3.14)(1.08^2)(10^6)$$

$$SA = 4(3.14)(1.1664)(10^6)$$

$$SA = 14.649984 \times 10^6$$

$$SA = 1.47 \times 10^7$$

26.

$$(1.60 \times 10^{-19}) \cdot (6.02 \times 10^{23})$$

$$9.632 \times 10^4$$

27.

$$(2.5 \times 10^{13}) \div (3.7 \times 10^4)$$

$$0.67567568 \times 10^9$$

$$6.76 \times 10^8$$

Mixed Review

28.

$$\frac{5.6}{18} = \frac{x}{100}$$

$560 = 18x$ The concentration is approximately 31% sugar.

$$x \approx 31.11$$

29.

$$\begin{cases} 6x + 3y = 18 \\ -15 = 11y - 5x \end{cases}$$
$$-15 = 11y - 5x \rightarrow -5x + 11y = -15$$

$$-5x + 11y = -15 \rightarrow 6(-5x + 11y = -15) \rightarrow -30x + 66y = -90$$

$$6x + 3y = 18 \rightarrow 5(6x + 3y = 18) \rightarrow 30x + 15y = 90$$

$$30x + 15y = 90$$

$$\underline{-30x + 66y = -90}$$

$$0x + 81y = 0$$

$$81y = 0$$

$$y = 0$$

$$6x + 3y = 18$$

$$6x + 3(0) = 18$$

$$6x = 18$$

$$x = 3$$

Check

$$6x + 3y = 18 \quad -15 = 11y - 5x$$

$$6(3) + 3(0) = 18 \quad -15 = 11(0) - 5(3)$$

$$18 + 0 = 18 \quad -15 = 0 - 15$$

$$18 = 18 \quad -15 = -15$$

30. Graph the function by creating a table: $f(x) = 2x^2$. Use the following values for x : $-5 \leq x \leq 5$.

x	$2x^2$	f(x)
-5	$2(-5^2)=2(25)=50$	50
-4	$2(-4^2)=2(16)=32$	32
-3	$2(-3^2)=2(9)=18$	18
-2	$2(-2^2)=2(4)=8$	8
-1	$2(-1^2)=2(1)=2$	2
0	$2(0^2)=2(0)=0$	0
1	$2(1^2)=2(1)=2$	2
2	$2(2^2)=2(4)=8$	8
3	$2(3^2)=2(9)=18$	18
4	$2(4^2)=2(16)=32$	32
5	$2(5^2)=2(25)=50$	50

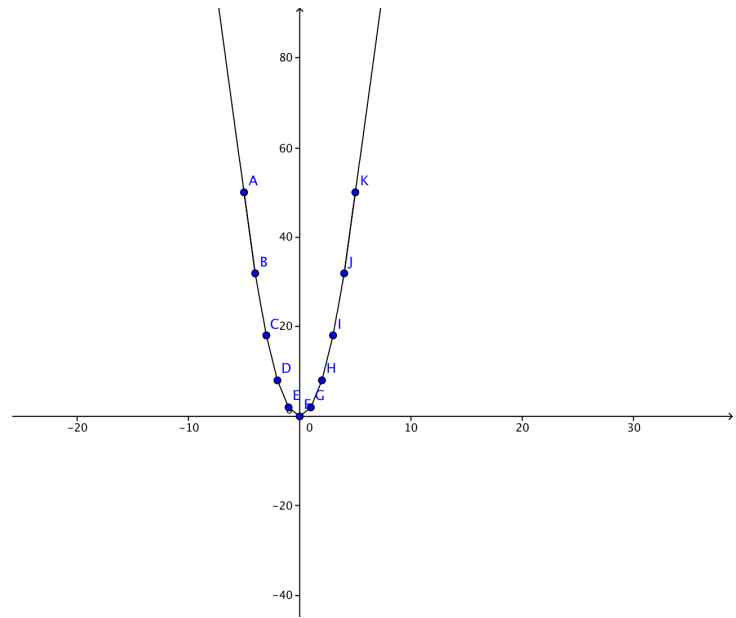

$$31. \frac{5a^6b^2c^{-6}}{a^{11}b} = 5 \cdot a^{6-11} \cdot b^{2-1} \cdot c^{-6} = 5 \cdot a^{-5} \cdot b \cdot c^{-6} = 5 \cdot \frac{1}{a^5} \cdot b \cdot \frac{1}{c^6} = \frac{5b}{a^5c^6}$$

32.

$$(2.3 \times 10^8) \div (3.07 \times 10^8)$$

$$.74917 \times 10^0$$

$$7.4917 \times 10^{-1}$$

$$230,000,000 / 307,006,550 = 0.749169683838993$$

33.

$$V = l(w)(h)$$

$$312 = 12(8)(h)$$

$$312 = 96h$$

$$h = 3.25$$

The box is 3.25 inches tall.

Quick Quiz

$$1. \frac{(2x^{-4}y^3)^{-3} \cdot x^{-3}y^{-2}}{-2x^0y^2}$$

$$\frac{2^{-3} \cdot x^{-4 \cdot -3} \cdot y^{3 \cdot -3} \cdot x^{-3} \cdot y^{-2}}{-2(1)y^2}$$

$$\frac{8^{-1} \cdot x^{12} \cdot y^{-9} \cdot x^{-3} \cdot y^{-2}}{-2y^2}$$

$$\frac{8^{-1} \cdot x^{12+(-3)} \cdot y^{-9+(-2)}}{-2y^2}$$

$$\frac{x^9 \cdot y^{-11}}{8(-2)y^2} = x^9 \cdot y^{-11-2} \cdot \frac{1}{-16} = \frac{x^9}{-16y^{13}}$$

2.

1. Two million = 2,000,000 = 2.0×10^6

2. Five and a half million = 5,500,000 = 5.5×10^6

3. Three hundred seventy five thousand = 375,000 = 3.75×10^5

3. FALSE

$$\left(\frac{5}{4}\right)^{-3} \neq -\frac{125}{64}$$

$$\left(\frac{5}{4}\right)^{-3} = \frac{64}{125}$$

Lesson 8.5

Exponential Growth Functions

1. The general equation for an exponential equation is $y = a(b)^x$, where a is the starting value, b is the growth factor, x is the number of times the growth factor has been applied and y is the solution.
2. In a linear equation we often find a variable with an exponent, while in an exponential growth equation the variable is always the exponent.
3. The growth factor of an exponential equation must always be greater than 1.
4. FALSE The form of the equation is correct, but b must be greater than 1.
5. The y -intercept (when $x = 0$) in any exponential growth function will always be equal to a or the starting value. (regardless of what b is, when it is raised to the x power and $x = 0$ then $b^x=1$, and a times 1 is always a)

6. $y = 3^x$

x	3^x	y
-3	$3^{-3} = 1/3^3 = 1/27$	1/27
-2	$3^{-2} = 1/3^2 = 1/9$	1/9
-1	$3^{-1} = 1/3^1 = 1/3$	1/3
0	$3^0 = 1$	1
1	$3^1 = 3$	3
2	$3^2 = 9$	9
3	$3^3 = 27$	27

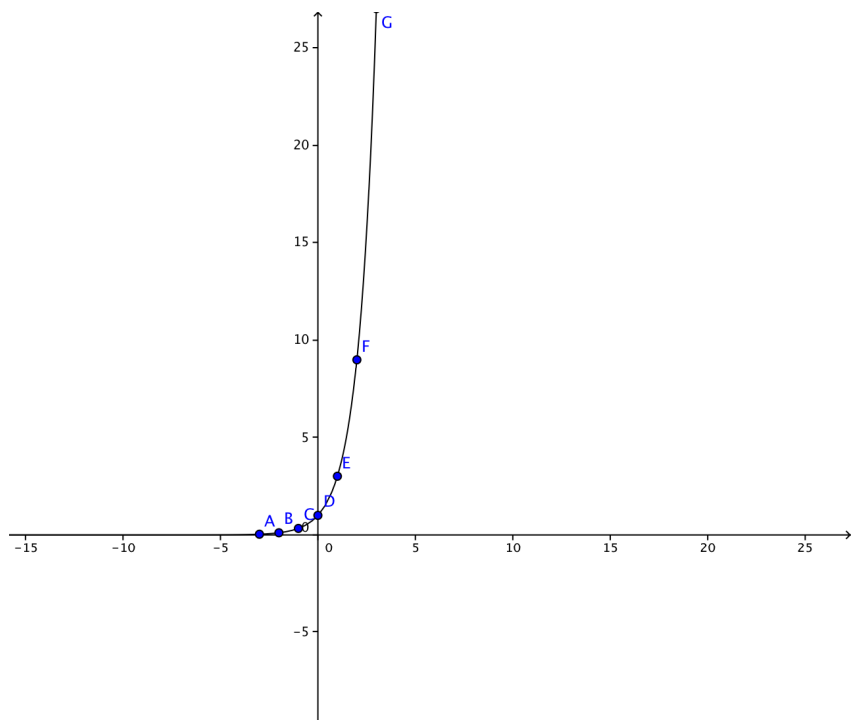

7. $y = 2^x$

x	2^x	y
-3	$2^{-3} = 1/2^3 = 1/8$	$1/8=0.125$
-2	$2^{-2} = 1/2^2 = 1/4$	$1/4=0.25$
-1	$2^{-1} = 1/2^1 = 1/2$	$1/2=0.5$
0	$2^0 = 1$	1
1	$2^1 = 2$	2
2	$2^2 = 4$	4
3	$2^3 = 8$	8

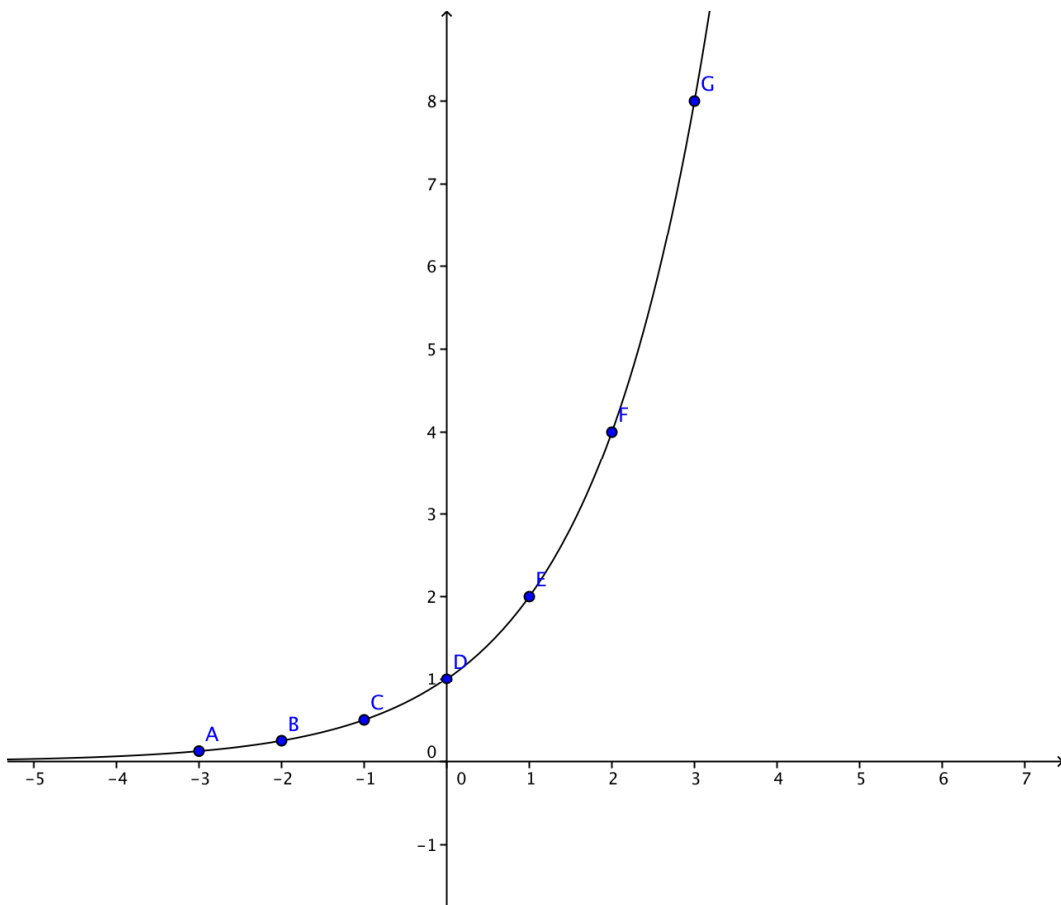

8. $y = 5 \cdot 3^x$

x	$5 \cdot 3^x$	y
-3	$5 \cdot 3^{-3} = 5 \cdot 1/3^3 = 5 \cdot 1/27 = 5/27$	$5/27 = 0.185$
-2	$5 \cdot 3^{-2} = 5 \cdot 1/3^2 = 5 \cdot 1/9 = 5/9$	$5/9 = 0.556$
-1	$5 \cdot 3^{-1} = 5 \cdot 1/3^1 = 5 \cdot 1/3 = 5/3$	$5/3 = 1.667$
0	$5 \cdot 3^0 = 5 \cdot 1 = 5$	5
1	$5 \cdot 3^1 = 5 \cdot 3 = 15$	15
2	$5 \cdot 3^2 = 5 \cdot 9 = 45$	45
3	$5 \cdot 3^3 = 5 \cdot 27 = 135$	135

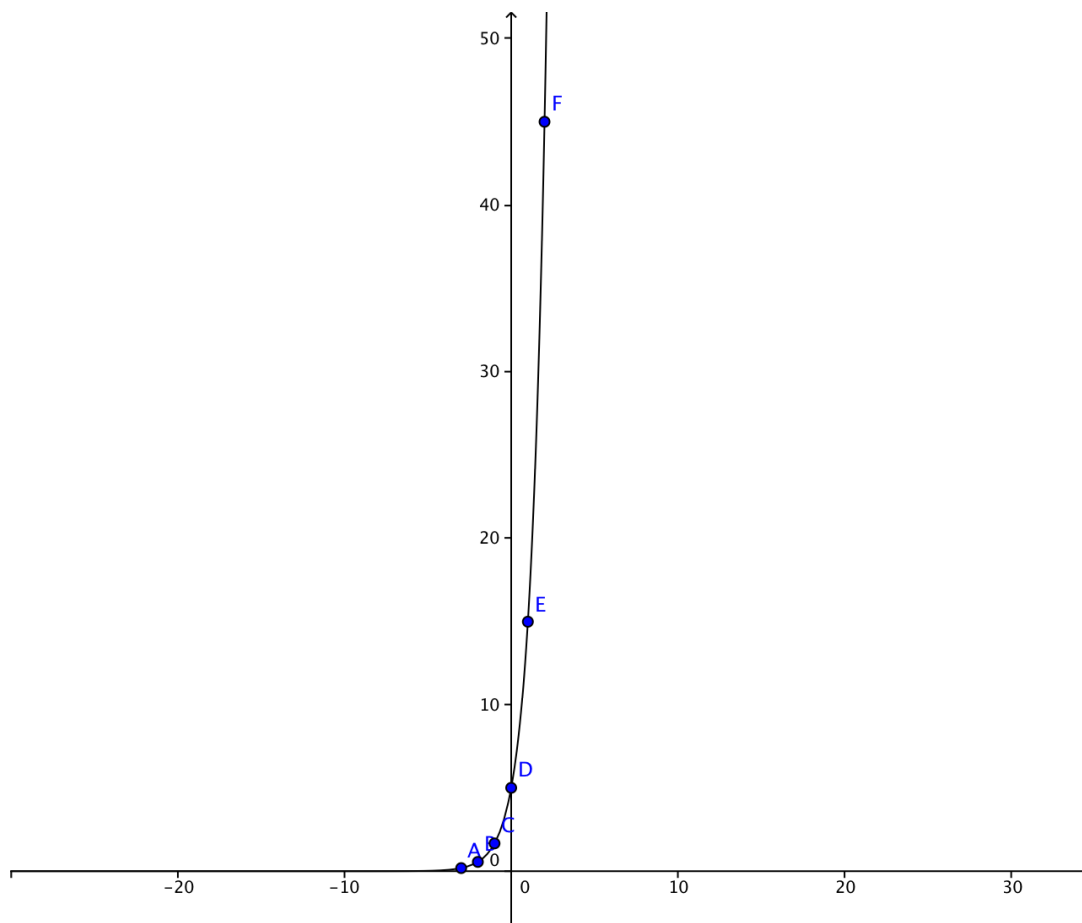

$$9. y = \frac{1}{2} \cdot 4^x$$

x	$\frac{1}{2} \cdot 4^x$	y
-3	$\frac{1}{2} \cdot 4^{-3} = \frac{1}{2} \cdot \frac{1}{4^3} = \frac{1}{2} \cdot \frac{1}{64} = \frac{1}{128}$	$\frac{1}{128} = 0.0078$
-2	$\frac{1}{2} \cdot 4^{-2} = \frac{1}{2} \cdot \frac{1}{4^2} = \frac{1}{2} \cdot \frac{1}{16} = \frac{1}{32}$	$\frac{1}{32} = 0.0312$
-1	$\frac{1}{2} \cdot 4^{-1} = \frac{1}{2} \cdot \frac{1}{4^1} = \frac{1}{2} \cdot \frac{1}{4} = \frac{1}{8}$	$\frac{1}{8} = 0.125$
0	$\frac{1}{2} \cdot 4^0 = \frac{1}{2} \cdot 1 = \frac{1}{2}$	$\frac{1}{2} = 0.5$
1	$\frac{1}{2} \cdot 4^1 = \frac{1}{2} \cdot 4 = 2$	2
2	$\frac{1}{2} \cdot 4^2 = \frac{1}{2} \cdot 16 = 8$	8
3	$\frac{1}{2} \cdot 4^3 = \frac{1}{2} \cdot 64 = 32$	32

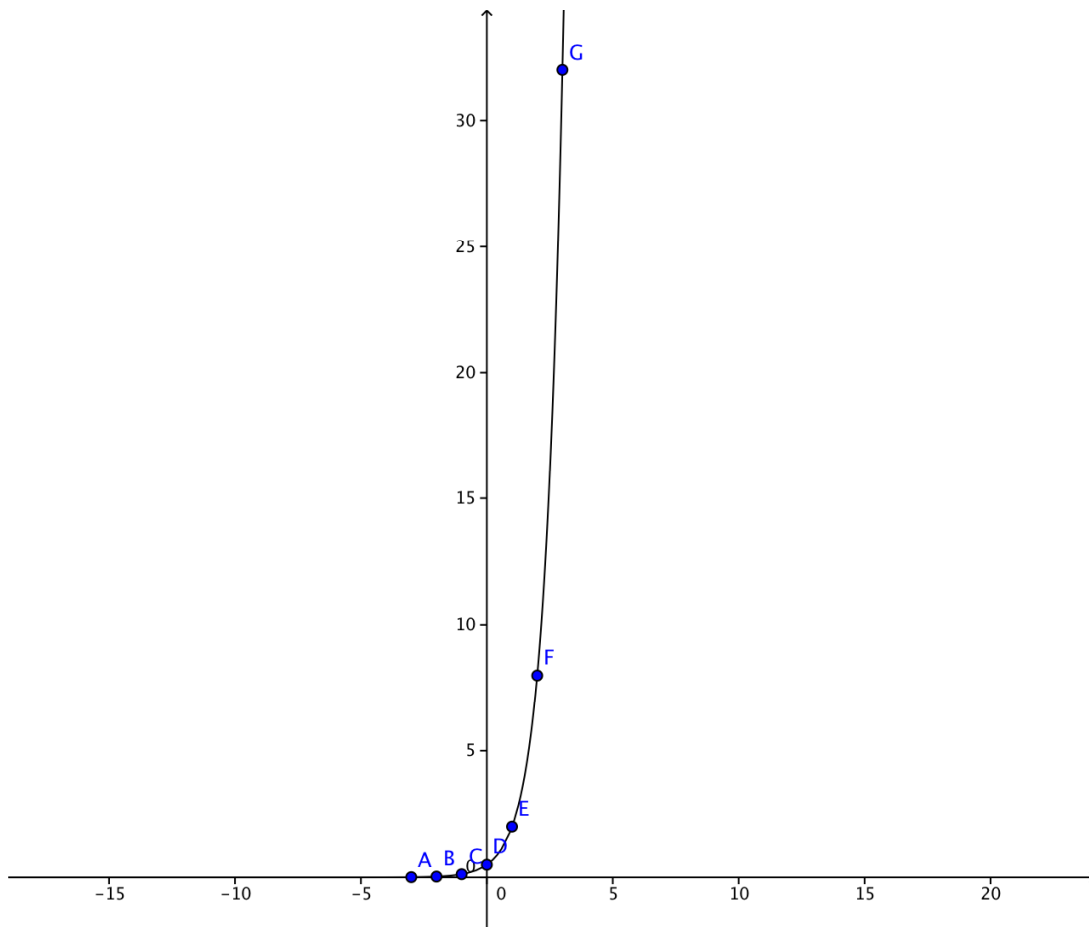

10. $f(x) = \frac{1}{3} \cdot 7^x$

x	$\frac{1}{3} \cdot 7^x$	f(x)
-3	$\frac{1}{3} \cdot 7^{-3} = \frac{1}{3} \cdot \frac{1}{7^3} = \frac{1}{3} \cdot \frac{1}{343} = \frac{1}{1029}$	$\frac{1}{1029}$
-2	$\frac{1}{3} \cdot 7^{-2} = \frac{1}{3} \cdot \frac{1}{7^2} = \frac{1}{3} \cdot \frac{1}{49} = \frac{1}{147}$	$\frac{1}{147}$
-1	$\frac{1}{3} \cdot 7^{-1} = \frac{1}{3} \cdot \frac{1}{7} = \frac{1}{21}$	$\frac{1}{21}$
0	$\frac{1}{3} \cdot 7^0 = \frac{1}{3} \cdot 1 = \frac{1}{3}$	$\frac{1}{3}$
1	$\frac{1}{3} \cdot 7^1 = \frac{1}{3} \cdot 7 = \frac{7}{3}$	2.3334
2	$\frac{1}{3} \cdot 7^2 = \frac{1}{3} \cdot 49 = \frac{49}{3}$	16.3334
3	$\frac{1}{3} \cdot 7^3 = \frac{1}{3} \cdot 343 = \frac{343}{3}$	114.3334

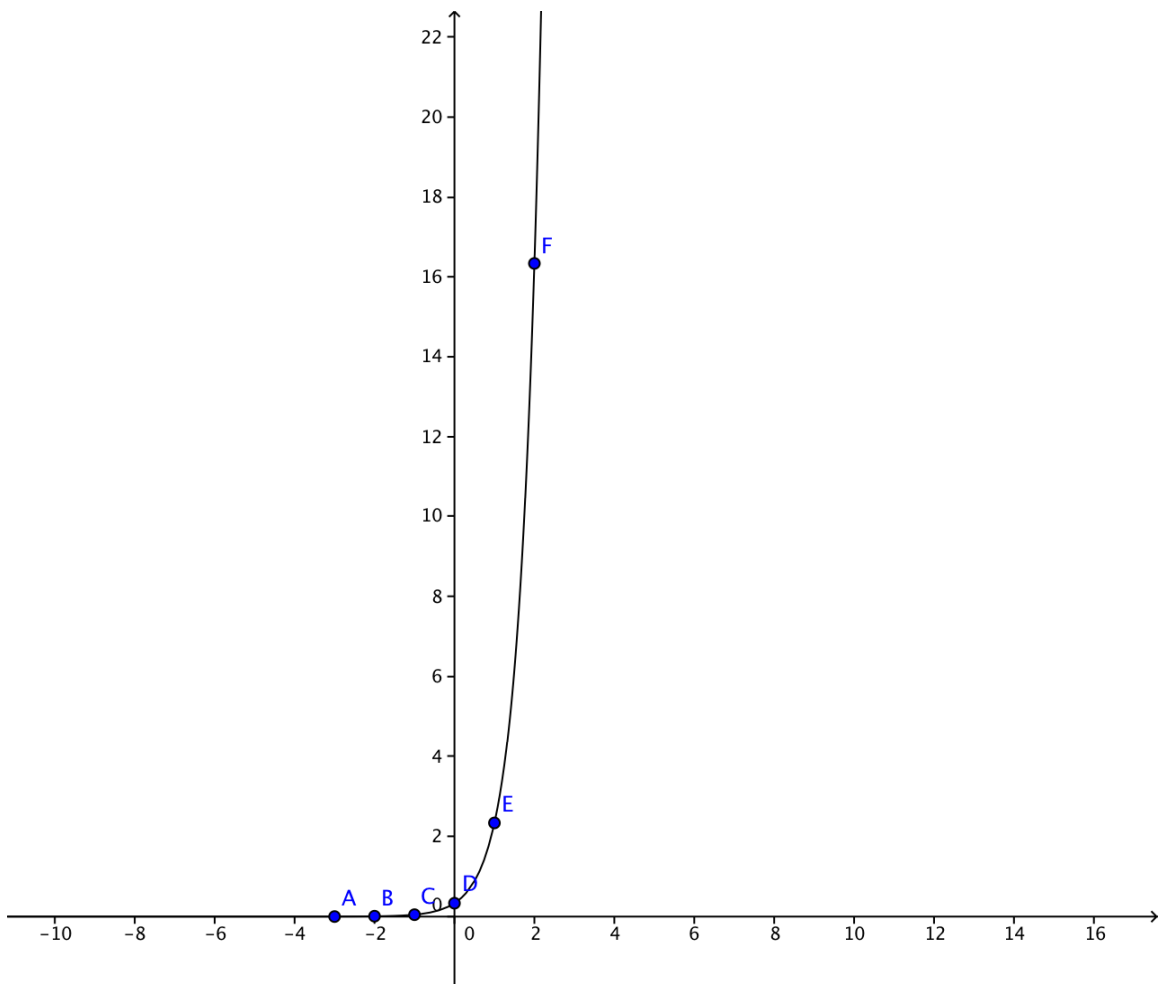

11. $f(x) = 2 \cdot 3^x$

x	$2 \cdot 3^x$	f(x)
-3	$2 \cdot 3^{-3} = 2 \cdot 1/3^3 = 2 \cdot 1/27 = 2/27$	$2/27 = 0.074$
-2	$2 \cdot 3^{-2} = 2 \cdot 1/3^2 = 2 \cdot 1/9 = 2/9$	$2/9 = 0.2223$
-1	$2 \cdot 3^{-1} = 2 \cdot 1/3^1 = 2 \cdot 1/3 = 2/3$	$2/3 = 0.6667$
0	$2 \cdot 3^0 = 2 \cdot 1 = 2$	2
1	$2 \cdot 3^1 = 2 \cdot 3 = 6$	6
2	$2 \cdot 3^2 = 2 \cdot 9 = 18$	18
3	$2 \cdot 3^3 = 2 \cdot 27 = 54$	54

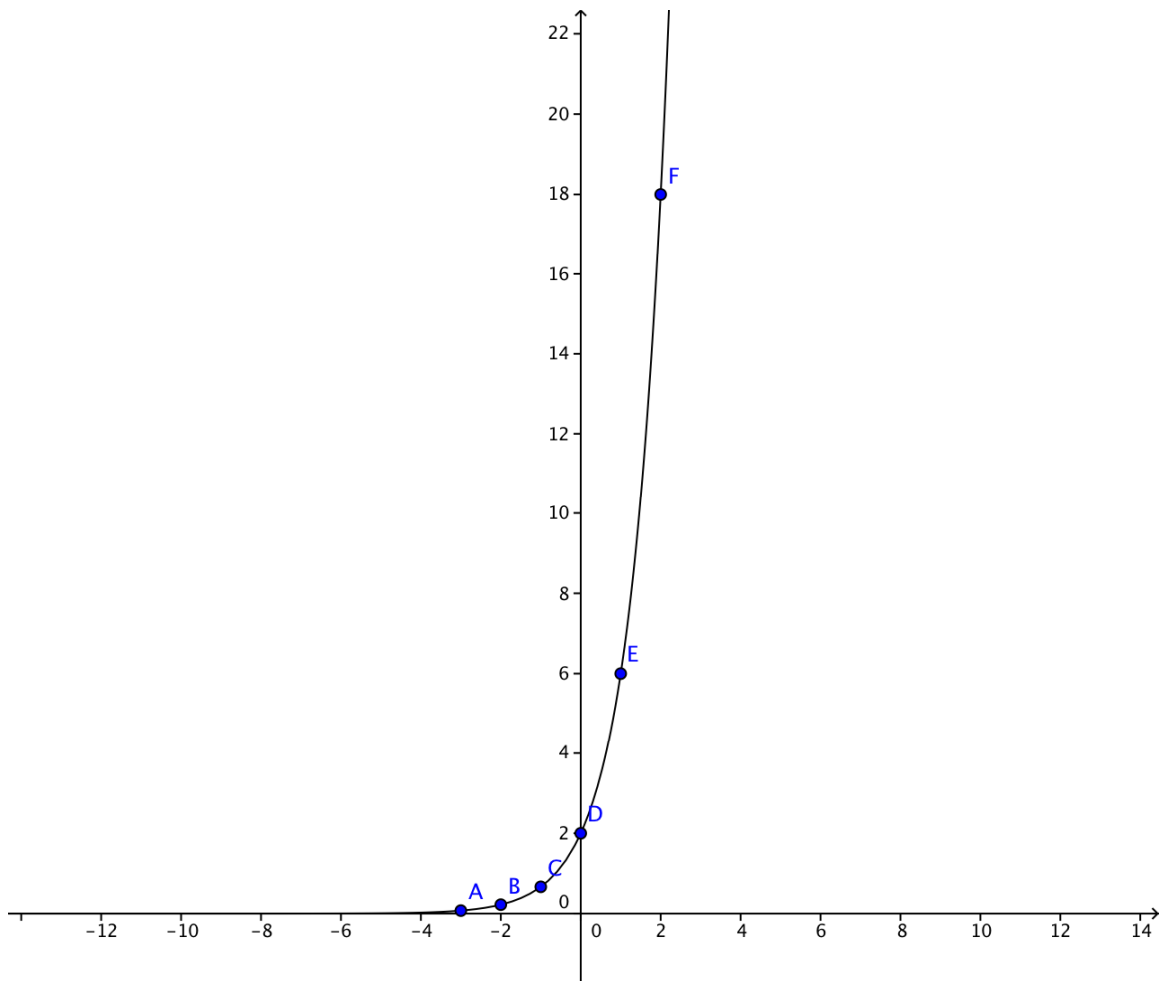

12. $y = 40 \cdot 4^x$

x	$40 \cdot 4^x$	y
-3	$40 \cdot 4^{-3} = 40 \cdot 1/4^3 = 40 \cdot 1/64 = 40/64 = 5/8$	$5/8 = 0.625$
-2	$40 \cdot 4^{-2} = 40 \cdot 1/4^2 = 40 \cdot 1/16 = 40/16 = 5/2$	$5/2 = 2.5$
-1	$40 \cdot 4^{-1} = 40 \cdot 1/4^1 = 40 \cdot 1/4 = 40/4 = 10$	10
0	$40 \cdot 4^0 = 40 \cdot 1 = 40$	40
1	$40 \cdot 4^1 = 40 \cdot 4 = 160$	160
2	$40 \cdot 4^2 = 40 \cdot 16 = 640$	640
3	$40 \cdot 4^3 = 40 \cdot 64 = 2560$	2560

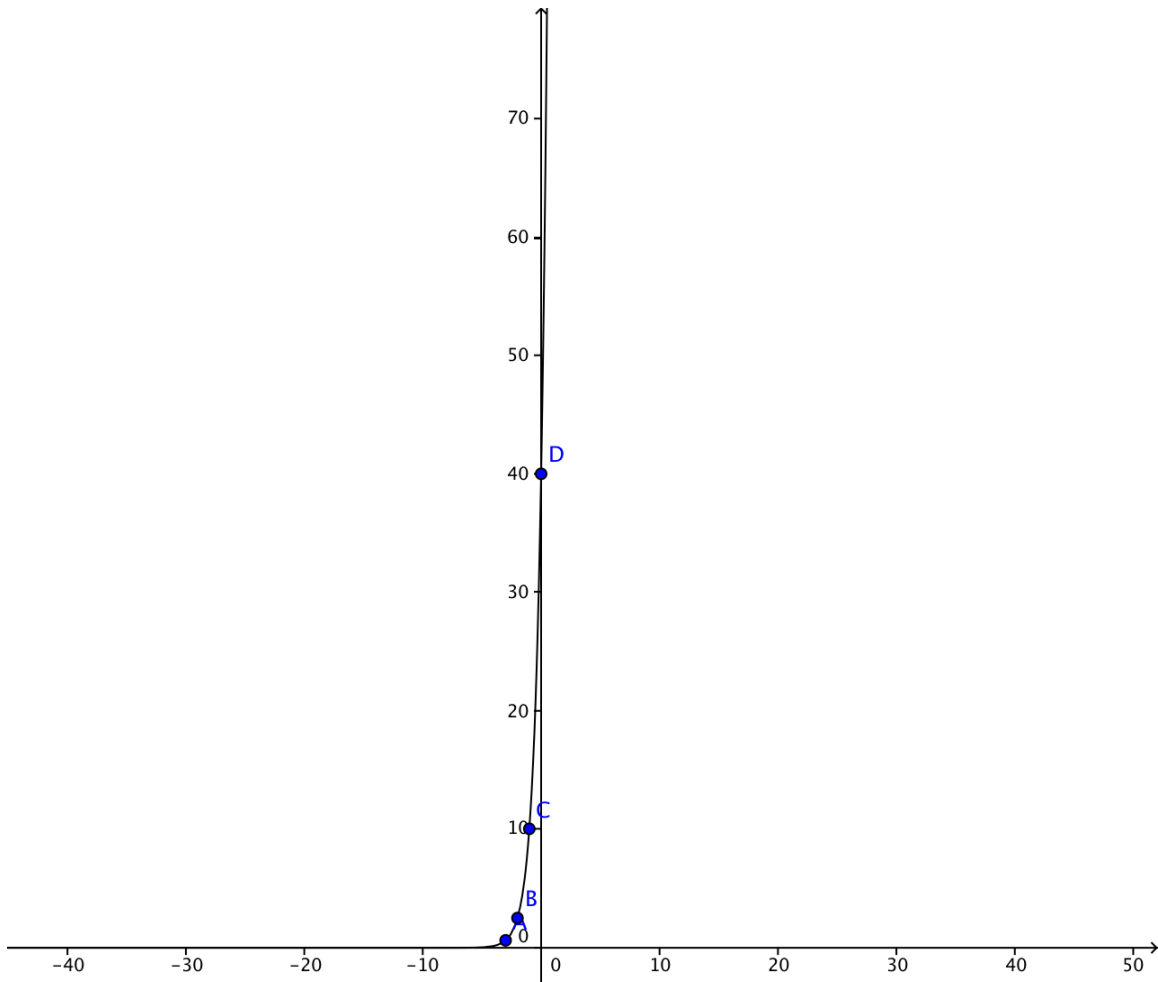

13. $y = 3 \cdot 10^x$

x	$3 \cdot 10^x$	y
-3	$3 \cdot 10^{-3} = 3 \cdot 0.001 = 0.003$	0.003
-2	$3 \cdot 10^{-2} = 3 \cdot 0.01 = 0.03$	0.03
-1	$3 \cdot 10^{-1} = 3 \cdot 0.1 = 0.3$	0.3
0	$3 \cdot 10^0 = 3 \cdot 1 = 3$	3
1	$3 \cdot 10^1 = 3 \cdot 10 = 30$	30
2	$3 \cdot 10^2 = 3 \cdot 100 = 300$	300
3	$3 \cdot 10^3 = 3 \cdot 1000 = 3000$	3000

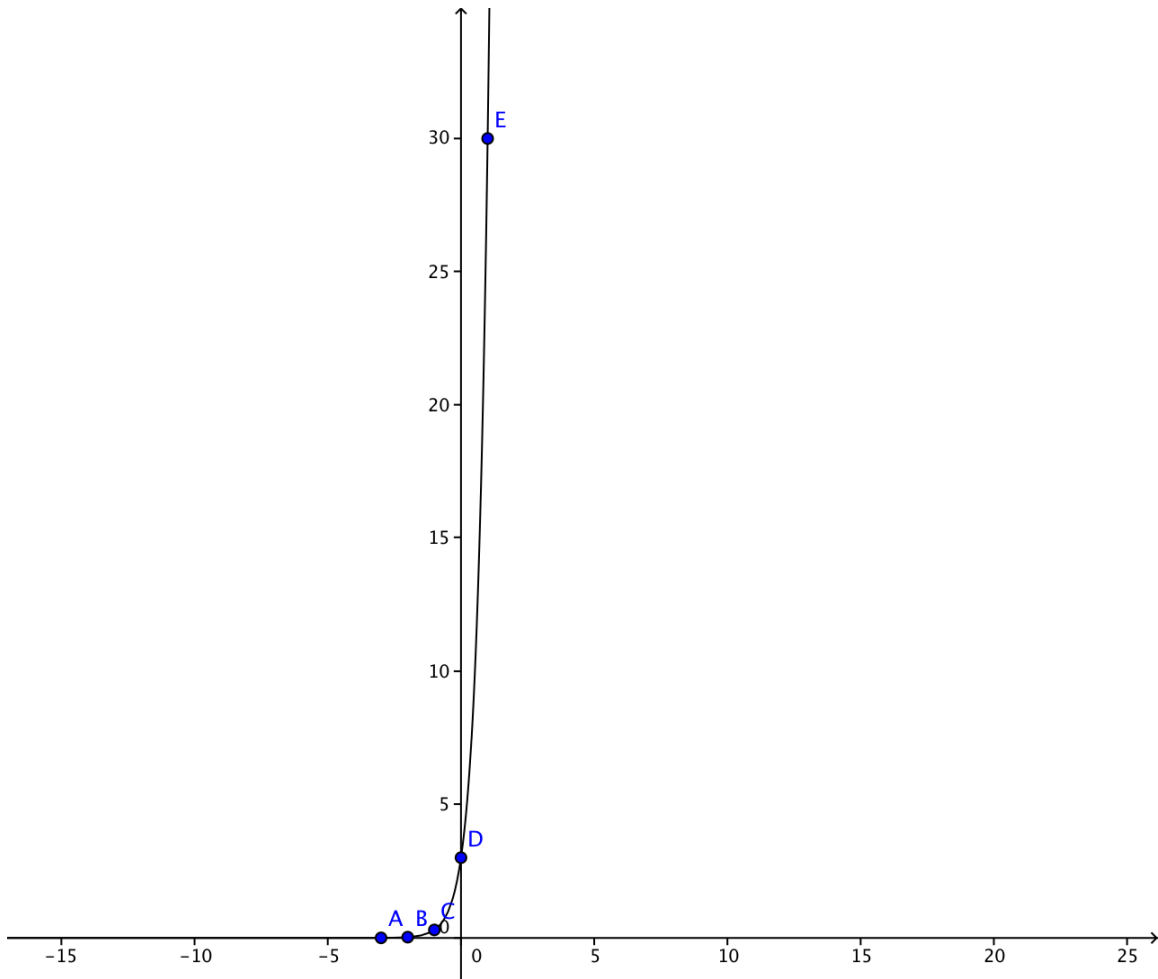

14.

The exponential growth formula is $y=a(b)^x$

$$a=113,505$$

$$b=100\% + 1.2\%=1.012$$

$$x=2012-2007=5$$

$$y = a(b)^x$$

$$y = 113,505(1.012)^5$$

$$y = (113,505)(1.061457)$$

$$y = 120,480.68$$

The population in 2012 will be approximately 120,481.

15.

The exponential growth formula is $y=a(b)^x$

$$a=20$$

$$b=2$$

$$x=15/2=7.5$$

$$y = a(b)^x$$

$$y = 20(2)^{7.5}$$

$$y = 20(181.0193)$$

$$y = 3620.386$$

There will be approximately 3620 bacteria present 15 hours into the experiment.

16.

The exponential growth formula is $y=a(b)^x$

$$a=\$12$$

$$b=100\%+2.3\%=1.023$$

$$x=5 \text{ years}$$

$$y = a(b)^x$$

$$y = 12(1.023)^5$$

$$y = (12)(1.120413)$$

$$y = 13.444956$$

In five years the same item will cost approximately \$13.45

17.

The exponential growth formula is $y=a(b)^x$

$$a=10 \text{ people}$$

$$b=10$$

$$x=6 \text{ weeks}$$

$$y = a(b)^x$$

$$y = 10(10)^6$$

$$y = 10^7$$

$$y = 10,000,000$$

If everyone maintains the chain then 10 million people will receive the letter the sixth week.

18.

The exponential growth formula is $y = a(b)^x$

$$a = \$200$$

$$b = 100\% + 7.5\% = 1.075$$

$$x = 21 - 10 = 11 \text{ years}$$

$$y = a(b)^x$$

$$y = 200(1.075)^{11}$$

$$y = 200(2.215609)$$

$$y = 443.1218$$

By her 21st birthday Nadia will have approximately \$443.12 in her account.

Mixed Review

19.

The total number of elements in the set consisting of the alphabets is 26. Of these the elements of interest are M, K and L. The total number of desired elements is 3. This allows us to calculate the probability of choosing the letters M, K or L when a letter is randomly chosen from the alphabet as $\frac{3}{26}$. The required probability is $\frac{3}{26}$.

20.

$$t^4 \cdot t^{\frac{1}{2}}$$

$$9^4 \cdot 9^{\frac{1}{2}}$$

$$6561 \cdot \sqrt{9}$$

$$6561 \cdot 3$$

$$19683$$

21.

$$28 - (x - 16)$$

$$28 - x + 16$$

$$44 - x$$

22. $y - 1 = \frac{1}{3}(x + 6)$

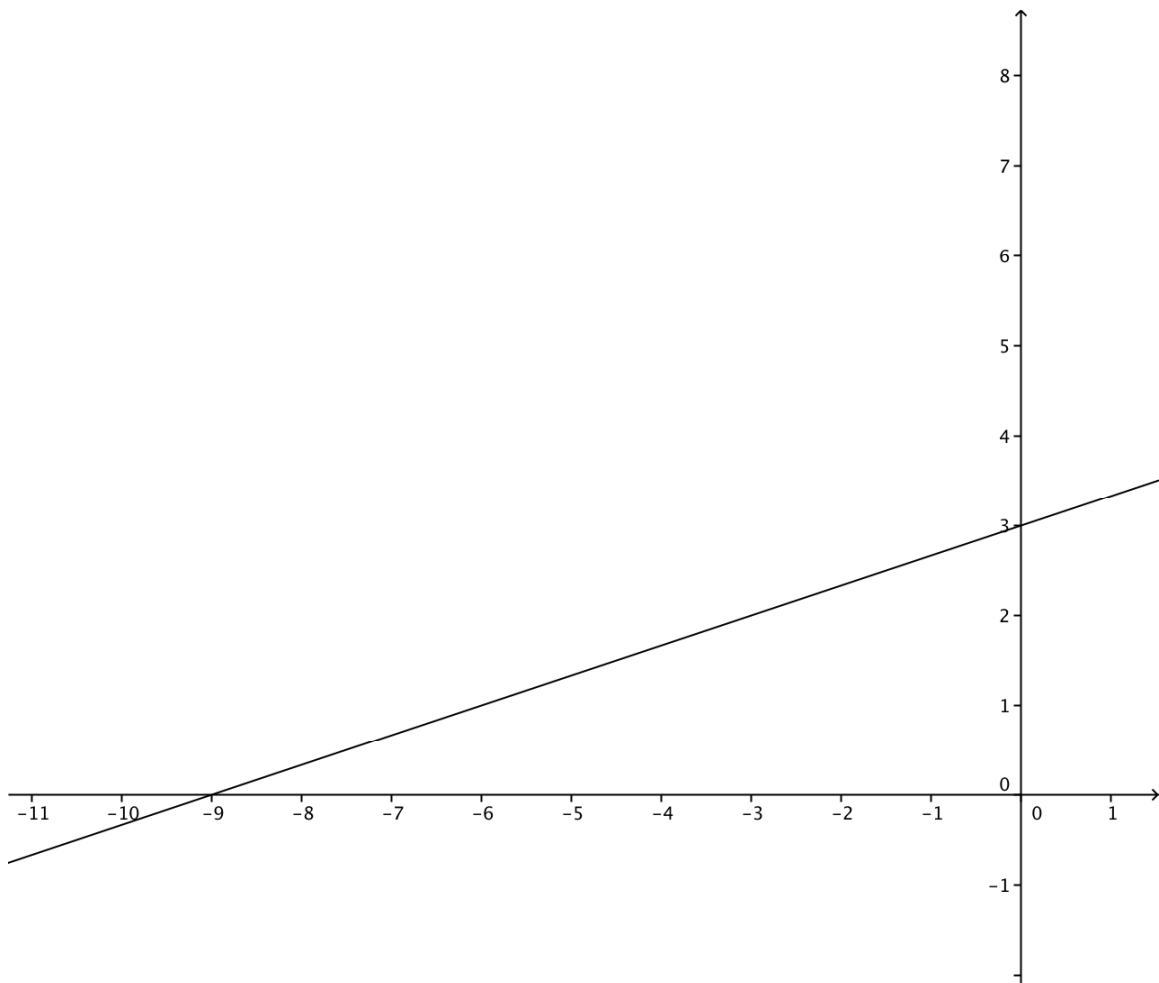

Lesson 8.6

Exponential Decay Functions

1. Exponential decay is when a function decreases from its original value regularly according to the noted decay factor.
2. “b” in a exponential decay function must always be a fraction between 0 and 1.
3. If $f(x) = a(b)^x$ then $f(0)$ is always equal to a. (b^0 will always equal 1 and $a \cdot 1$ is a). This means that the y-intercept of an exponential function is always equal to a or the starting value.

4. $y = \frac{1}{5}^x$

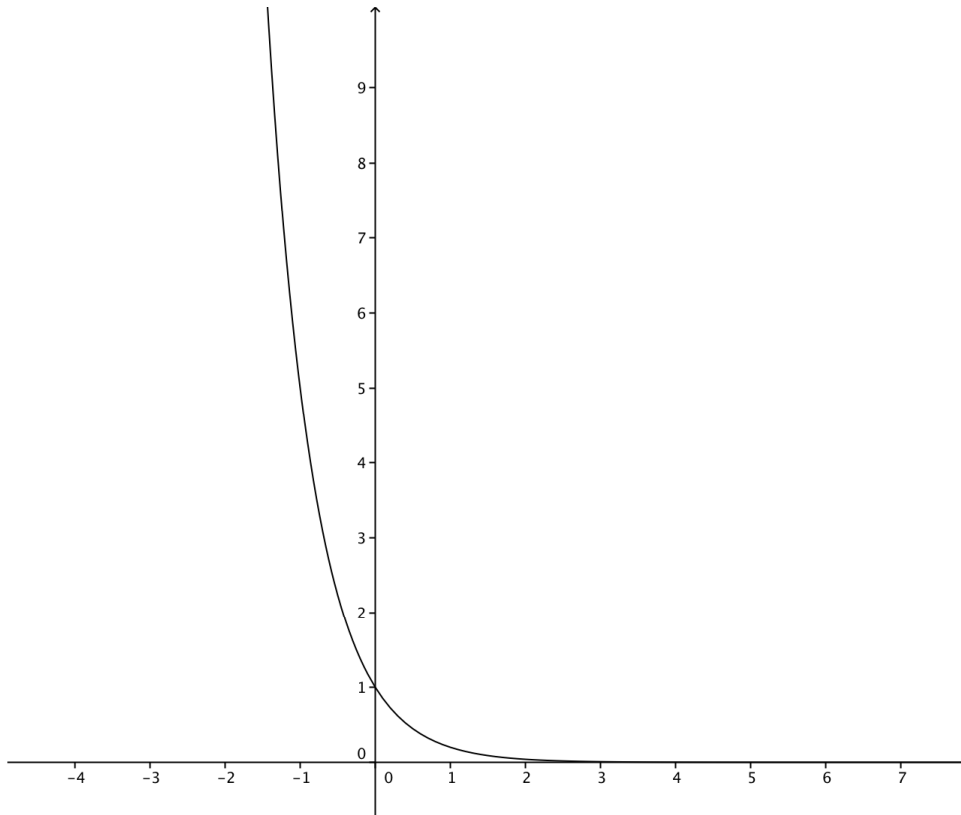

5. $y = 4 \cdot \left(\frac{2}{3}\right)^x$

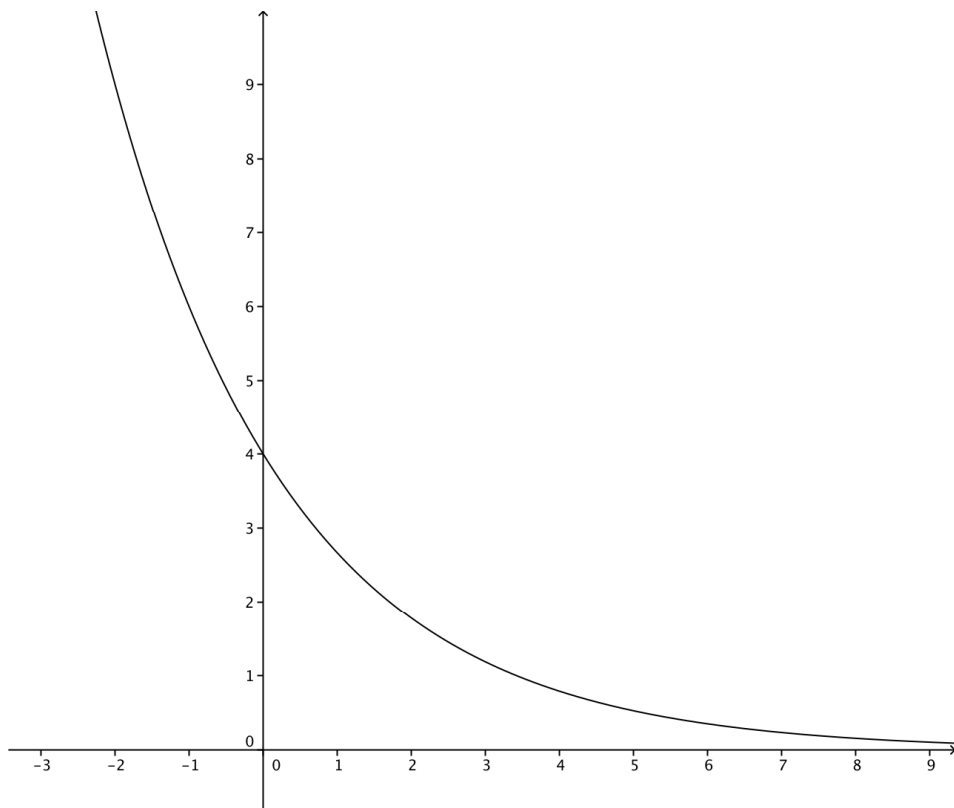

6. $y = 3^{-x}$

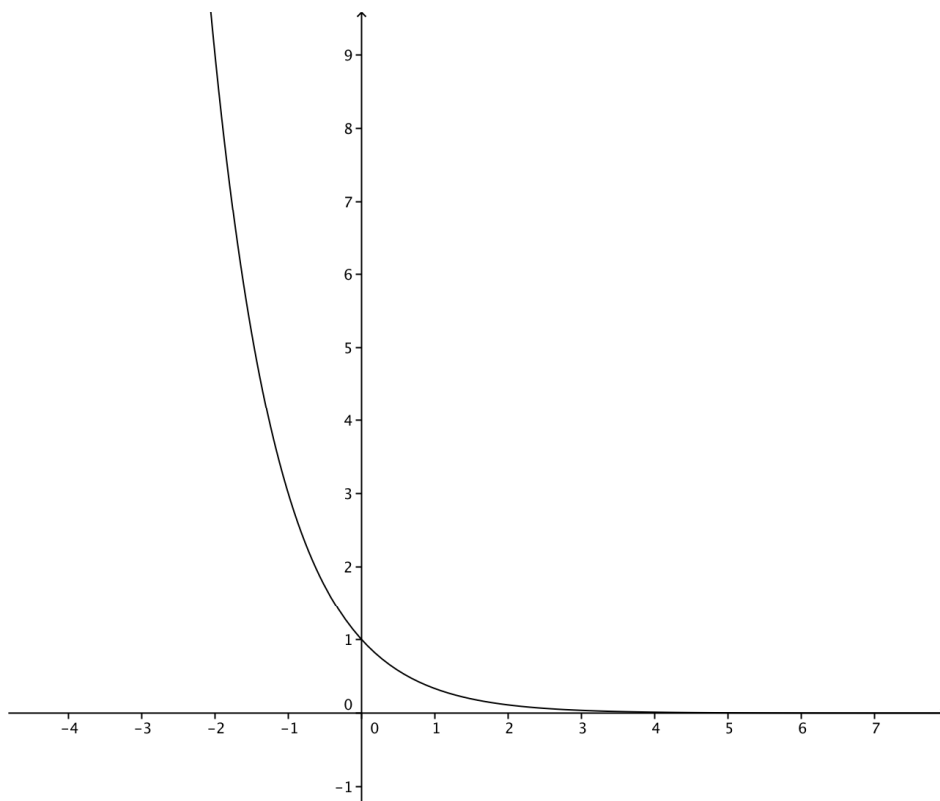

$$7. y = \frac{3}{4} \cdot 6^{-x}$$

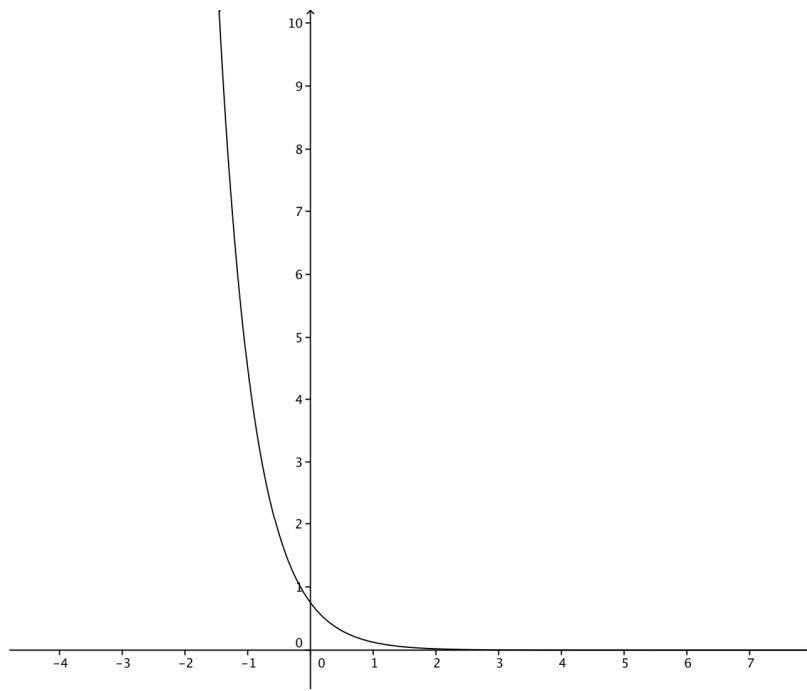

8.

1.

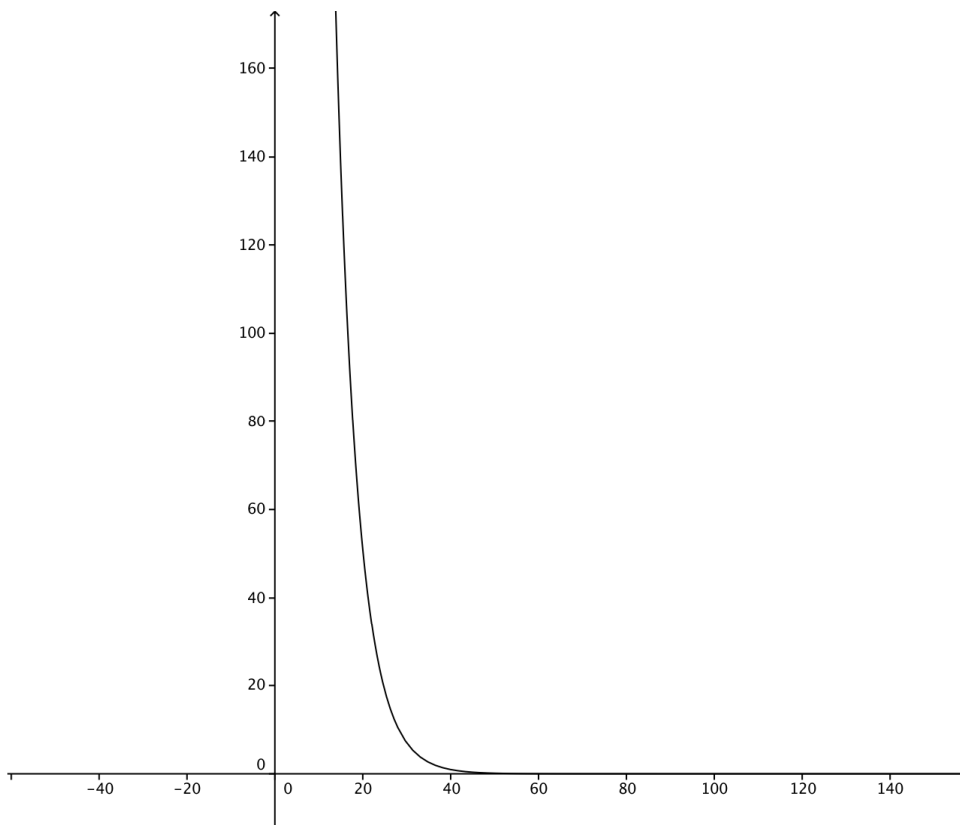

2. $y = 2700(0.82)^x$

$$y = 2700(0.82)^{10}$$

3. $y = 2700(.137448)$

$$y = 371.1096$$

The ATV is worth approximately \$371.11 after 10 years.

9.

1. If $y = a(b)^x$ then $a = 10,112,620$ and $b = 0.995$ and $x =$ the number of years difference from 2004.

$$y = a(b)^x$$

$$y = 10,112,620(0.995)^x$$

2. $x = 2012 - 2004 = 7$

$$y = 10,112,620(0.995)^8$$

$$y = 10,112,620(0.96069304)$$

$$y \approx 9,715,124$$

The population in 2012 will be approximately 9,715,124.

3. We will make a table to find when $y = 9,900,000$. We know that x must be greater than zero and less than 8, based on our previous calculations.

x	$10,112,620(0.995)^x$	y
1	$10,112,620(0.995)^1$	10,062,057
2	$10,112,620(0.995)^2$	10,011,747
3	$10,112,620(0.995)^3$	9,961,688
4	$10,112,620(0.995)^4$	9,911,879
5	$10,112,620(0.995)^5$	9,862,320
6	$10,112,620(0.995)^6$	

We can see that the solution must be greater than 4 and less than 5. If desired we can continue our chart using x values that fall between 4 and 5 and we would find that the answer falls between 4.2 and 4.3.

(The exact answer would be found using a logarithm)

$$\left. \begin{aligned} 9,900,000 &= 10,112,620(0.995)^x \\ 9,900,000 \div 10,112,620 &= 0.995^x \\ 0.978974785961 &= 0.995^x \\ \log(0.978974785961) &= x \log(0.995) \\ -0.009228493548 &= x(-0.002176919254) \\ x &\approx 4.239 \end{aligned} \right\}$$

4. $x = 2000 - 2004 = -4$

$$y = 10,112,620(0.995)^{-4}$$

$$y = 10,112,620(1.0202525)$$

$$y \approx 10,317,426$$

The population in 2000 would have been approximately 10,317,426.

10.

1.

Year	0	27	54	81	108	135
Amount	35	17.5	8.75	4.375	2.1875	1.09375

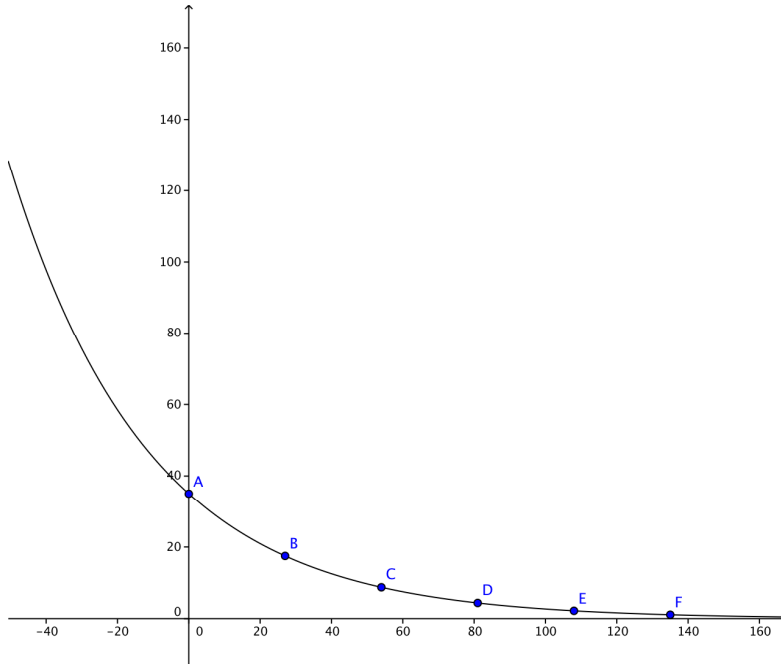

2. If $y = a(b)^x$ then in this case $a = 35$ (starting value) and $b = \frac{1}{2}$ (the decay factor). However we must also take into consideration that the decay factor is only being applied at intervals of 27 years. Therefore the time is x but the exponent is $x/27$.
 $y = 35(1/2)^{x/27}$

$$3. y = 35(1/2)^{x/27}$$

$$y = 35\left(\frac{1}{2}\right)^{\frac{92}{27}}$$

$$y = 35\left(\frac{1}{2}\right)^{3.4}$$

$$y = (35)(0.0947323)$$

$$y \approx 3.3156$$

11.

1. The growth factor is 0.70

2. The initial value is 1

3. $V(d) = 0.70^d$

$$V(65) = 0.70^{65}$$

$$V(65) = .0000000000854$$

$$V(65) = 8.54 \times 10^{-11}$$

12.

1. The bacteria population is reduced by $\frac{1}{4}$ each day, therefore there are $\frac{3}{4}$ left each day.

Bacteria	2,000,000	1,500,000	1,125,000	843,750	632,812.50	474,609.38	355,957.04	266,967.78
Day	0	1	2	3	4	5	6	7

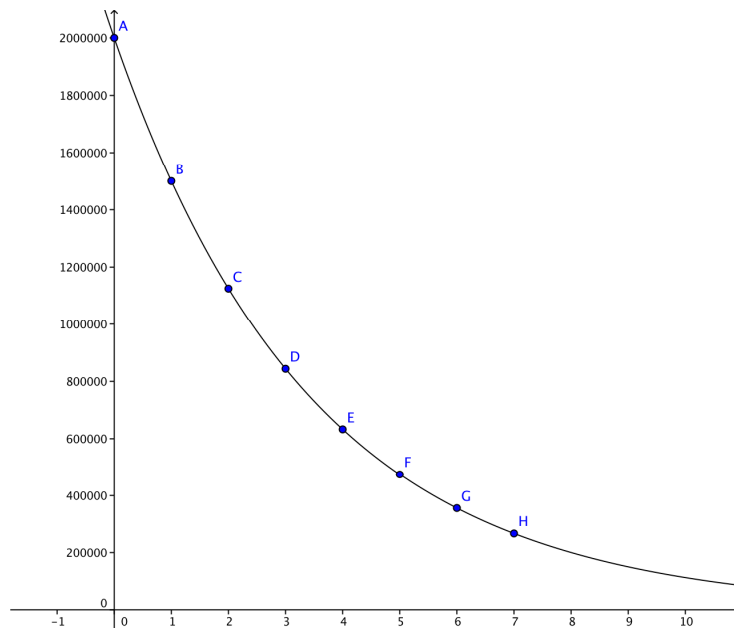

2. $y = a(b)^x$ The initial value is 2,000,000 and the growth factor is $\frac{3}{4}$ or .75, with x= time in days $y = 2,000,000(0.75)^x$

$$3. y = 2000000(0.75)^x \quad x=10$$

$$y = 2000000(0.75)^{10}$$

$$y = 2000000(0.0563135147095)$$

$$y = 112,627.029419$$

$$y \approx 112,627$$

$$4. y = 2000000(0.75)^x \quad x=14$$

$$y = 2000000(0.75)^{14}$$

$$y = 2000000(0.0178179480135)$$

$$y = 35635.896027$$

$$y \approx 35,636$$

Mixed Review

13.

$$\begin{aligned} 1. y &= a(b)^x \\ a &= 14,578 \\ b &= 100\% + 2.14\% = 1.0214 \\ x &= \text{the number of years before or after 2010} \\ y &= 14578(1.0214)^x \end{aligned}$$

$$\begin{aligned} 2. x &= 2015 - 2010 = 5 \\ y &= 14578(1.0214)^5 \\ y &= 14578(1.1116786565) \\ y &= 16206.051454457 \\ y &\approx 16,206 \end{aligned}$$

$$\begin{aligned} 3. x &= 2000 - 2010 = -10 \\ y &= 14578(1.0214)^{-10} \\ y &= 14578(0.809173152302) \\ y &= 11796.1262143 \\ y &\approx 11,796 \end{aligned}$$

14.

diameter = 11 inches
radius = 5.5 inches = $\frac{11}{2}$

$$v = \frac{4}{3} \pi r^3$$

$$v = \frac{4}{3} \left(\frac{22}{7} \right) \left(\frac{11}{2} \right)^3$$

$$v = \frac{4}{3} \left(\frac{22}{7} \right) \left(\frac{1331}{8} \right)$$

$$v = \frac{14641}{21}$$

$$v \approx 697$$

$$15. \frac{6x^2}{14y^3} \cdot \frac{7y}{x^8} \cdot x^0 y = \frac{6x^{2+0} 7y^{1+1}}{14y^3 x^8} = \frac{6x^2 y^2}{14y^3 x^8} = \left(\frac{6}{14}\right) x^{2-8} y^{2-3} = \left(\frac{3}{7}\right) x^{-6} y^{-1} = \frac{3}{7x^6 y}$$

$$16. 3(x^2 y^3 x)^2 = 3(x^{2+1} y^3)^2 = 3(x^{3+2} y^{3+2}) = 3x^6 y^6$$

$$17. ax + by = c$$

$$y - 16 + x = -4x + 6y + 1$$

$$y - 16 + x + 4x = 6y + 1$$

$$y - 16 + 5x = 6y + 1$$

$$y - 16 + 5x - 6y = 1$$

$$-5y - 16 + 5x = 1$$

$$-5y + 5x = 1 + 16$$

$$5x - 5y = 17$$

Lesson 8.7

Geometric Sequences and Exponential Functions

1. A *geometric sequence* is a sequence of numbers in which each number in the sequence is found by multiplying the previous number by a fixed amount called the common ratio.

2.

1. $a_4 = 1 \cdot 2^3 = 8$

2. $a_{10} = 1 \cdot 2^9 = 512$

3. $a_{25} = 1 \cdot 2^{24} = 16777216$

4. $a_{60} = 1 \cdot 2^{59} = 576460752303000000 \approx 5.76 \times 10^{17}$

3. Yes the example is a geometric sequence. If we divide any number by the number preceding it we always get the same answer: -1. Therefore it is a sequence found by multiplying the previous number by a common ratio and therefore a geometric sequence.

4.

$$a_n = a_1 r^{n-1}$$

$$a_1 = 1$$

$$r = 2$$

$$n - 1 = 19$$

$$a_{20} = 1 \cdot 2^{19} = 2^{19} = 524288 = \$5242.88$$

5. $6 \div 8 = .75$

$r = 0.75$

6. $4 \div 2 = 2$

$r = 2$

7. $3 \div 9 = \frac{3}{9} = \frac{1}{3}$

$r = \frac{1}{3}$

8. $-8 \div 2 = -4$

$r = -4$

9. $a_1 = 2, r = 3$
2, 6, 18, 54, 162

10. $a_1 = 90, r = -\frac{1}{3}$
90, -30, 10, $-\frac{10}{3}, \frac{10}{9}$

11. $a_1 = 6, r = -2$
6, -12, 24, -48, 96

12. 3, _, 48, 192, _
 $192 \div 48 = 4, r = 4$
3, 12, 48, 192, 768

13.
In a geometric progression we know that $a_n = a_1 r^{n-1}$ where a_n is any number in the progression, a_1 is the first term and r is the common ratio.

$$a_1 = 81$$

$$a_5 = 1$$

$$n - 1 = 4$$

$$1 = 81 \cdot r^4$$

$$\frac{1}{81} = r^4$$

$$\sqrt[4]{\frac{1}{81}} = r$$

$$r = \frac{\sqrt[4]{1}}{\sqrt[4]{81}} = \pm \frac{1}{3}$$

When $r = 1/3$ then the progression is 81, 27, 9, 3, 1

When $r = -1/3$ then the progression is 81, -27, 9, -3, 1

14.

In a geometric progression we know that $a_n = a_1 r^{n-1}$ where a_n is any number in the progression, a_1 is the first term and r is the common ratio.

$$a_1 = \frac{9}{4}$$

$$a_4 = \frac{2}{3}$$

$$n - 1 = 3$$

$$\frac{2}{3} = \frac{9}{4} \cdot r^3$$

$$\frac{8}{27} = r^3$$

$$\sqrt[3]{\frac{8}{27}} = r$$

$$r = \frac{\sqrt[3]{8}}{\sqrt[3]{27}} = \frac{2}{3}$$

$r = 2/3$, therefore the progression is $9/4, 3/2, 1, 2/3, 4/9$

15. $a_6 = 4 \cdot 2^5 = 128$

16. $a_4 = -7 \cdot \left(-\frac{3}{4}\right)^3 = 2.953125$

17. $a_{10} = -10 \cdot (-3)^9 = 196830$

18.

1.

$$a_n = a_1 r^{n-1}$$

$$a_1 = 4 \text{ ft}$$

$$r = 80\% = 0.80$$

$$a_n = 4 \cdot (0.8)^{n-1}$$

2.

$$a_n = 4 \cdot (0.8)^{n-1}$$

$$a_5 = 4 \cdot (0.8)^{5-1}$$

$$a_5 = 4 \cdot (0.8)^4$$

$$a_5 = 4 \cdot (0.4096)$$

$$a_5 = 1.6384$$

19.

1.

$$a_n = a_1 r^{n-1}$$

$$n = 8$$

$$a_1 = 1$$

$$r = 3$$

$$n - 1 = 7$$

$$a_8 = 1 \cdot 3^7 = 2187$$

2. We know that n has to be greater than 3 and less than 7. Let's make a table.

n	$1 \cdot 3^{n-1}$	a_n
4	$1 \cdot 3^{4-1} = 3^3 = 27$	27
5	$1 \cdot 3^{5-1} = 3^4 = 81$	81
6	$1 \cdot 3^{6-1} = 3^5 = 243$	243
7	$1 \cdot 3^{7-1} = 3^6 =$	729

Now we know that n must be between 6 and 7. Let's make another table.

n	$1 \cdot 3^{n-1}$	a_n
6.1	$1 \cdot 3^{6.1-1} = 3^{5.1} = 271$	271
6.2	$1 \cdot 3^{6.2-1} = 3^{5.2} = 303$	303
6.3	$1 \cdot 3^{6.3-1} = 3^{5.3} = 338$	338
6.4	$1 \cdot 3^{6.4-1} = 3^{5.4} =$	377

We can see that n falls between 6.3 and 6.4.

(The exact answer is found using logarithms.)

$$\left(\begin{array}{l} 343 = 1 \cdot 3^{n-1} \\ 343 = 3^{n-1} \\ (n-1) \log 3 = \log(343) \\ (n-1)(0.47712125472) = 2.53529412004 \\ n-1 = 5.31373124748 \\ n = 6.31373124748 \\ n \approx 6.314 \end{array} \right)$$

20.

1.

$$a_n = a_1 r^{n-1}$$

$$n = 3$$

$$a_1 = 20$$

$$r = 75\% = 0.75$$

$$n - 1 = 2$$

$$a_3 = 20 \cdot (0.75)^2 = 20 \cdot 0.5625 = 11.25$$

The ball will bounce 11.25 feet high after the third bounce.

2.

$$a_n = a_1 r^{n-1}$$

$$n = 17$$

$$a_1 = 20$$

$$r = 75\% = 0.75$$

$$n - 1 = 16$$

$$a_{17} = 20 \cdot (0.75)^{16} = 20 \cdot (0.010022595758) = 0.2005$$

The ball will bounce 0.2005 feet high after the seventeenth bounce.

21.

1.

$$a_n = a_1 r^{n-1}$$

$$n = 3$$

$$a_1 = 120$$

$$r = 60\% = 0.60$$

$$n - 1 = 2$$

$$a_3 = 120 \cdot (0.60)^2 = 120 \cdot 0.36 = 43.2$$

The rope will stretch 43.2 feet on the third bounce.

2.

$$a_n = a_1 r^{n-1}$$

$$n = 12$$

$$a_1 = 120$$

$$r = 60\% = 0.60$$

$$n - 1 = 11$$

$$a_{12} = 120 \cdot (0.60)^{11} = 120 \cdot (0.00362797056) = 0.4354$$

The rope will stretch 0.4354 feet on the twelfth bounce.

22.

1. The formula for exponential growth is $y = a(b)^x$, where a is the initial value (30 in this case), b is the growth factor (2 in this case) and x is the time passed (in this case the exponent will be 5 hours divided by 30 minutes, because the growth factor is applied every 30 minutes. $x = 10$)

$$y = a(b)^x$$

$$y = 30 \cdot 2^{10} = 30 \cdot 1024 = 30720$$

2. We know that $x > 10$, let's make a table and find some practice values.

x	$30 \cdot 2^x$	y
11	$30 \cdot 2^{11} = 30 \cdot 2048 = 61440$	61,440
12	$30 \cdot 2^{12} = 30 \cdot 4096 = 122880$	122,880
13	$30 \cdot 2^{13} = 30 \cdot 8192 = 245760$	245,760
14	$30 \cdot 2^{14} = 30 \cdot 16384 = 491520$	491,520
15	$30 \cdot 2^{15} = 30 \cdot 32768 = 983040$	983,040
16	$30 \cdot 2^{16} = 30 \cdot 65536 = 1966080$	1,966,080

Now we know that $x > 15$ and $x < 16$. We have to remember that x = the number of 30 minute intervals that have passed. So $15 \cdot 30$ minutes = 450 minutes / 60 minutes = 7.5 hours.

23.

1. The formula for exponential decay is $y = a(b)^x$, where a is the initial value (12mg in this case), b is the growth factor ($1/2$ in this case) and x is the time passed (this question asks for 4 half life periods so $x=4$)

$$y = a(b)^x$$

$$y = 12 \cdot (0.5)^4 = 12 \cdot 0.0625 = 0.75$$

2. We know that $0 < x < 4$ half-life periods. Let's make a table.

x	$12 \cdot 0.5^x$	y
1	$12 \cdot 0.5^1 = 12 \cdot 0.5 = 6$	6
2	$12 \cdot 0.5^2 = 12 \cdot 0.25 = 3$	3

We can see that she will have less than 3 mg in her system after 2 half-life periods or 50 days. Anytime after 50 days she will have less than 3mg in her system.

3. The growth factor is $\frac{1}{2}$ or 0.5.

Mixed Review

24. $x^2 < 2x + 15$

25. $y = \frac{2}{3}x - 7$

(The equation is in $y = mx + b$ form, where m is the slope and b is the y-intercept.)

Slope = $\frac{2}{3}$

y-intercept is -7

26. $10! = 3628800$

27. 1 mile = 1760 yards

6 miles * 1760 = 10560 yards

28. $\frac{5y^2 - 3y^2}{4y^{11}} = \frac{2y^2}{4y^{11}} = \frac{1}{2} \cdot y^{2-11} = \frac{1}{2} y^{-9} = \frac{1}{2y^9}$

29. $3x^2 \cdot x^6 + 4x^3 x^5 = 3x^{2+6} + 4x^{3+5} = 3x^8 + 4x^8 = 7x^8$

30. $\left(\frac{27}{64}\right)^{-\frac{1}{3}} = \frac{\sqrt[3]{64}}{\sqrt[3]{27}} = \frac{4}{3} = 1\frac{1}{3}$

Lesson 8.8

Problem Solving Strategies

1.

The formula for exponential decay is $y = a(b)^x$, where a is the initial value (in this case simply 1), b is the growth factor (in this case the decay factor is 3.5% so the growth factor is 96.5% or 0.965) and x is the number of times the growth factor is applied (in this problem, the number of hours, which is 6.)

$$y = a(b)^x$$

$$y = 1 \cdot (0.965)^6$$

$$y = 1 \cdot (0.807539696082)$$

$$y \approx 0.808$$

After six hours there will be approximately 80.8% left.

2.

The formula for exponential decay is $y = a(b)^x$, where a is the initial value (in this case 1200), b is the growth factor (in this case the decay factor is 1.5% so the growth factor is 98.5% or 0.985) and x is the number of times the growth factor is applied (in this problem, the number of decades, which is $2020-1990=30/10=3$.)

$$y = a(b)^x$$

$$y = 1200 \cdot (0.985)^3$$

$$y = 1200 \cdot (0.955671625)$$

$$y = 1146.80595$$

$$y \approx 1147$$

In the year 2020 there will be approximately 1147 bird species left.

3

The formula for exponential growth is $y = a(b)^x$, where a is the initial value (in this case 200), b is the growth factor (in this case 100%+ 8% or 1.08) and x is the number of times the growth factor is applied (in this problem, the number of years, 2007-1999=8.)

$$y = a(b)^x$$

$$y = 200 \cdot (1.08)^8$$

$$y = 200 \cdot (1.85093021028)$$

$$y = 370.186042056$$

$$y \approx 370$$

In the year 2007 there would be approximately 370 stores in Nadia's chain.

4.

The formula for exponential growth is $y = a(b)^x$, where a is the initial value (in this case \$360), b is the growth factor (in this case 100%+ 7.25% or 1.0725) and x is the number of times the growth factor is applied (in this problem, the number of years, 12)

$$y = a(b)^x$$

$$y = 360 \cdot (1.0725)^{12}$$

$$y = 360 \cdot (2.31615495052)$$

$$y = 833.815782186$$

$$y \approx 833.82$$

In 12 years there will be approximately \$833.82 in the account.

Lesson 8.9

Chapter 8 Review

1. An *exponent* is the power of a number that shows how many times that number is multiplied by itself.

2. A *geometric sequence* is a sequence of numbers in which each number in the sequence is found by multiplying the previous number by a fixed amount called the common ratio.

3. $5 \cdot 5 \cdot 5 \cdot 5 = 5^4 = 625$

4. $(3x^2y^3) \cdot (4xy^2) = 12x^{2+1}y^{3+2} = 12x^3y^5$

5. $a^3 \cdot a^5 \cdot a^6 = a^{3+5+6} = a^{14}$

6. $(y^3)^5 = y^{3 \cdot 5} = y^{15}$

7. $(x \cdot x^3 \cdot x^5)^{10} = (x^{1+3+5})^{10} = (x^9)^{10} = x^{9 \cdot 10} = x^{90}$

8. $(2a^3b^3)^2 = 2^2 \cdot a^{3 \cdot 2} \cdot b^{3 \cdot 2} = 4a^6b^6$

9. $\frac{c^5}{c^3} = c^{5-3} = c^2$

10. $\frac{a^6}{a} = a^{6-1} = a^5$

11. $\frac{a^5b^4}{a^3b^2} = a^{5-3} \cdot b^{4-2} = a^2b^2$

12. $\frac{x^4y^5z^2}{x^3y^2z} = x^{4-3} \cdot y^{5-2} \cdot z^{2-1} = xy^3z$

13. $\frac{6^5}{6^5} = 1$

14. $\frac{y^2}{y^5} = y^{2-5} = y^{-3} = \frac{1}{y^3}$

$$15. \frac{7^3}{7^6} = 7^{3-6} = 7^{-3} = \frac{1}{7^3} = \frac{1}{343}$$

$$16. \frac{2}{x^3} = 2x^{-3}$$

$$17. \sqrt[4]{a^3} = a^{\frac{3}{4}}$$

$$18. \left(a^{\frac{1}{3}}\right)^2 = a^{\frac{1}{3} \cdot 2} = a^{\frac{2}{3}} = \sqrt[3]{a^2}$$

$$19. \left(\frac{x^2}{y^3}\right)^{\frac{1}{3}} = \frac{x^{2 \cdot \frac{1}{3}}}{y^{3 \cdot \frac{1}{3}}} = \frac{x^{\frac{2}{3}}}{y} = \frac{\sqrt[3]{x^2}}{y} = \sqrt[3]{x^2} \cdot y^{-1}$$

$$20. 557000 = 5.57 \times 10^5$$

$$21. 600000 = 6 \times 10^5$$

$$22. 20 = 2 \times 10^1$$

$$23. 0.04 = 4 \times 10^{-2}$$

$$24. 0.0417 = 4.17 \times 10^{-2}$$

$$25. 0.0000301 = 3.01 \times 10^{-5}$$

$$26. 384,403 \text{ km} = 3.84 \times 10^5 \text{ km}$$

$$27. 483,780,000 \text{ miles} = 4.8378 \times 10^8 \text{ miles}$$

$$28. 15 \text{ parts per billion} = 1.5 \times 10^{-8}$$

$$29. 3.53 \times 10^3 = 3530$$

$$30. 8.9 \times 10^6 = 8900000$$

$$31. 2.12 \times 10^6 = 2,120,000$$

$$32. 5.4 \times 10^1 = 54$$

$$33. 7.9 \times 10^{-3} = 0.0079$$

$$34. 4.69 \times 10^{-2} = 0.0469$$

35. $1.8 \times 10^{-5} = .000018$

36. $8.41 \times 10^{-3} = 0.00841$

37. $y = 3 \cdot (6)^x$

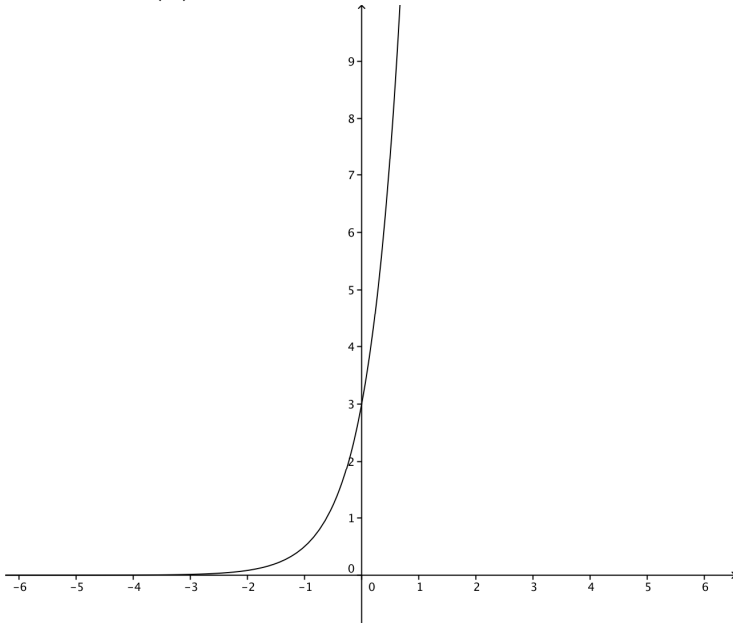

38. $y = 2 \cdot \left(\frac{1}{3}\right)^x$

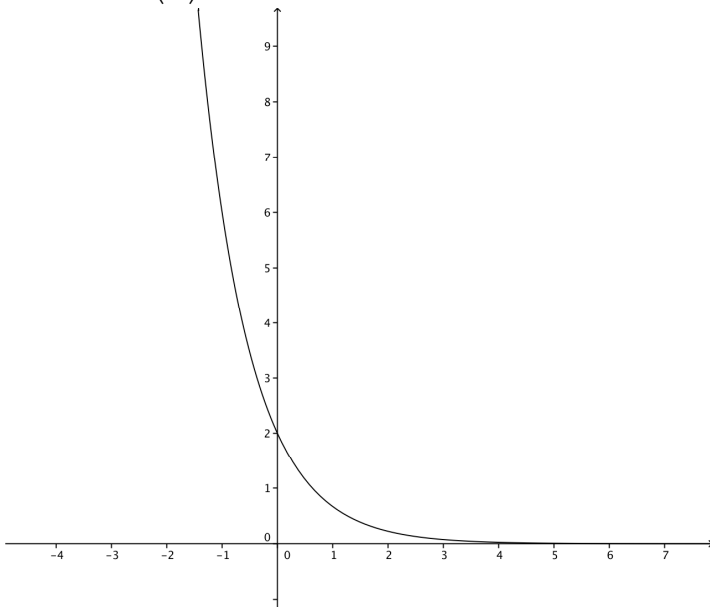

39.

$$y = 120 \cdot (0.75)^x$$

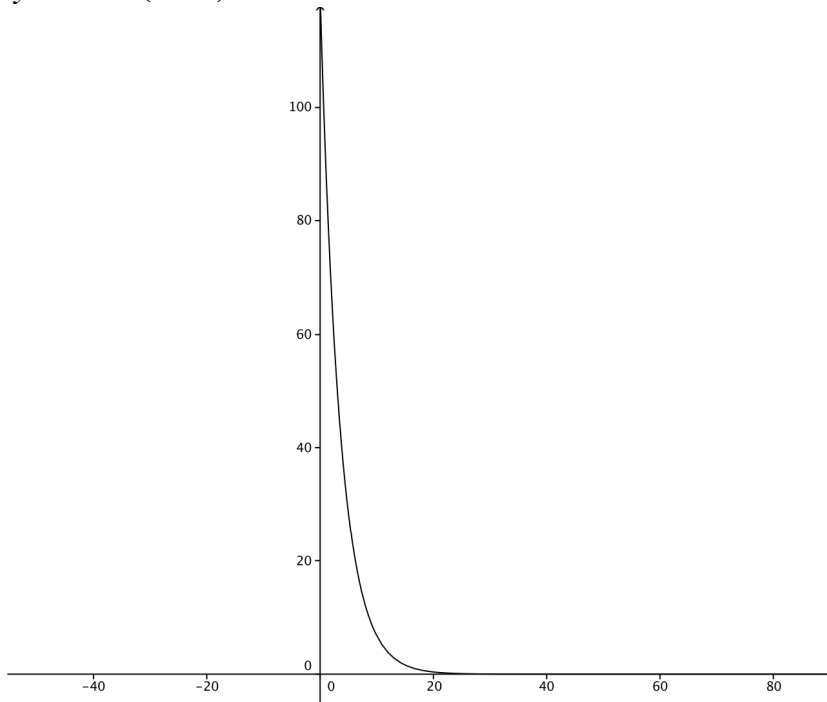

Marissa will run out of candy in approximately 20 days.

40.

$$y = 1500 \cdot (1.12)^x$$

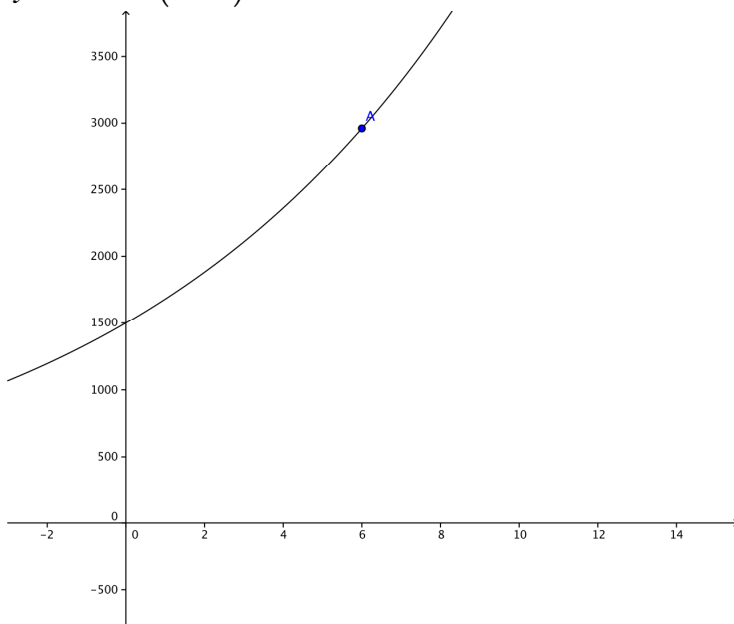

Jacoby will have approximately \$2900 in his account after 6 years.

41.

$$3/1=3$$

$$r=3$$

1, 3, 9, 27, 81

42.

$$625/125=5$$

$$r=5$$

1, 5, 25, 125, 625

43.

$$2401/343=7$$

$$r=7$$

7, 49, 343, 2401, 16807

44.

$$1.5/5=0.3$$

$$r=0.3$$

5, 1.5, 0.45, 0.135, 0.0405

45.

$$a_n = a_1 r^{n-1}$$

$$n = 30$$

$$a_1 = 2$$

$$r = 3$$

$$n - 1 = 29$$

$$a_{30} = 2 \cdot 3^{29} = 2 \cdot (68630377364900) = 137260754730000$$

Ben will have 137,260,754,730,000 ants at the end of a month.

Lesson 8.10
Chapter 8 Test

1. $x^3 \cdot x^4 \cdot x^5 = x^{3+4+5} = x^{12}$

2. $(a^3)^7 = a^{3 \cdot 7} = a^{21}$

3. $(y^2 z^4)^7 = y^{2 \cdot 7} \cdot z^{4 \cdot 7} = y^{14} z^{28}$

4. $\frac{a^3}{a^5} = a^{3-5} = a^{-2} = \frac{1}{a^2}$

5. $\frac{x^3 y^2}{x^6 y^4} = x^{3-6} \cdot y^{2-4} = x^{-3} y^{-2} = \frac{1}{x^3 y^2}$

6.

$$\left(\frac{3x^8 y^2}{9x^6 y^5}\right)^3 = \left(\frac{3}{9} \cdot x^{8-6} \cdot y^{2-5}\right)^3 = \left(\frac{1}{3} x^2 y^{-3}\right)^3 = \left(\frac{1}{3}\right)^3 \cdot x^{2 \cdot 3} \cdot y^{-3 \cdot 3} = \frac{1}{27} \cdot x^6 \cdot y^{-9} = \frac{x^6}{27y^9}$$

7. $\frac{3^4}{3^4} = 1$

8. $\frac{2}{x^3} = 2x^{-3}$

$$\sqrt[3]{5^6} = \sqrt[3]{15625} = 25$$

9.

$$\sqrt[3]{5^6} = 5^{\frac{6}{3}} = 5^2 = 25$$

10. $0.00002 = 2 \times 10^{-5}$

11.

Day	1	2	3	4	5	6	7	8	9	10	11
Turkeys	2	4	8	16	32	64	128	256	512	1024	2048

12.

$$y = a(b)^x$$

$$y = 89 \cdot (1.2)^{15}$$

$$y = 89 \cdot (15.4070215746)$$

$$y = 1371.22492014$$

$$y \approx 1371$$

After 15 years the population of the town will be approximately 1371 people.

13.

$$y = a(b)^x$$

$$y = 1 \cdot (0.975)^9$$

$$y = 1 \cdot (0.796235508571)$$

$$y \approx 0.7962$$

After 9 hours there will be approximately 79.6% of the substance left.

14.

$$y = a(b)^x$$

$$y = 100(0.84)^3$$

$$y = 100 \cdot 0.592704$$

$$y = 59.2704$$

There will be approximately 59 cockroaches left after 3 hours.

Algebra Solution Key
Chapter 9
Polynomials and Factoring; More on Probability

Lesson 9.1
Addition and Subtraction of Polynomials

1. A *Polynomial* is an expression made with constants, variables, and positive integer exponents of the variables.
2. A *Monomial* is a one termed polynomial. It can be a constant, a variable, or a combination of constants and variables.
3. The *degree* of a polynomial is the largest exponent of a single term. (The degree of a term is the sum of the powers on each variable in the term.)
4. The coefficient of the first term of a polynomial in standard form is called the *Leading Coefficient*.
5. $x^2 + 3x^{\frac{1}{2}}$ is NOT a polynomial because the second term has a fractional exponent.
6. $\frac{1}{3}x^2y - 9y^2$ IS a polynomial because it is only made up of constants and variables with positive integer exponents.
7. $3x^{-3}$ is NOT a polynomial because the term has a negative exponent.
8. $\frac{2}{3}t^2 - \frac{1}{t^2}$ is NOT a polynomial because the second term is equal to a variable with a negative exponent.
9. $3 - 2x \Rightarrow -2x + 3$ The degree of the polynomial is 1.
10. $8x^4 - x + 5x^2 + 11x^4 - 10 \Rightarrow 19x^4 + 5x^2 - x - 10$
The degree of the polynomial is 4.
11. $8 - 4x + 3x^3 \Rightarrow 3x^3 - 4x + 8$ The degree of the polynomial is 3.
12. $-16 + 5f^8 - 7f^3 \Rightarrow 5f^8 - 7f^3 - 16$ The degree of the polynomial is 8.
13. $-5 + 2x - 5x^2 + 8x^3 \Rightarrow 8x^3 - 5x^2 + 2x - 5$ The degree of the polynomial is 3.
14. $x^2 - 9x^4 + 12 \Rightarrow -9x^4 + x^2 + 12$ The degree of the polynomial is 4.

$$15. (x + 8) + (-3x - 5) = (x + -3x) + (8 + -5) = -2x + 3$$

16.

$$(8r^4 - 6r^2 - 3r + 9) + (3r^3 + 5r^2 + 12r - 9)$$

$$8r^4 + 3r^3 + (-6r^2 + 5r^2) + (-3r + 12r) + (9 + -9)$$

$$8r^4 + 3r^3 - r^2 + 9r$$

17.

$$(-2x^2 + 4x - 12) + (7x + x^2)$$

$$(-2x^2 + x^2) + (4x + 7x) - 12$$

$$-x^2 + 11x - 12$$

18.

$$(2a^2b - 2a + 9) + (5a^2b - 4b + 5)$$

$$(2a^2b + 5a^2b) - 2a - 4b + (9 + 5)$$

$$7a^2b - 2a - 4b + 14$$

19.

$$(6.9a^2 - 2.3b^2 + 2ab) + (3.1a - 2.5b^2 + b)$$

$$6.9a^2 + (2.3b^2 - 2.5b^2) + 2ab + 3.1a + b$$

$$6.9a^2 - 0.2b^2 + 2ab + 3.1a + b$$

20.

$$(-t + 15t^2) - (5t^2 + 2t - 9)$$

$$-t + 15t^2 - 5t^2 - 2t + 9$$

$$-t + 10t^2 - 2t + 9$$

$$10t^2 - 3t + 9$$

21.

$$(-y^2 + 4y - 5) - (5y^2 + 2y + 7)$$

$$-y^2 + 4y - 5 - 5y^2 - 2y - 7$$

$$-6y^2 + 2y - 12$$

22.

$$(-h^7 + 2h^5 + 13h^3 + 4h^2 - h - 1) - (-3h^5 + 20h^3 - 3h^2 + 8h - 4)$$

$$-h^7 + 2h^5 + 3h^5 + 13h^3 - 20h^3 + 4h^2 + 3h^2 - h - 8h - 1 + 4$$

$$-h^7 + 5h^5 - 7h^3 + 7h^2 - 9h + 3$$

23.

$$(-5m^2 - m) - (3m^2 + 4m - 5)$$

$$-5m^2 - 3m^2 - m - 4m + 5$$

$$-8m^2 - 5m + 5$$

24.

$$(2a^2b - 3ab^2 + 5a^2b^2) - (2a^2b^2 + 4a^2b - 5b^2)$$

$$5a^2b^2 - 2a^2b^2 + 2a^2b - 4a^2b - 3ab^2 + 5b^2$$

$$3a^2b^2 - 2a^2b - 3ab^2 + 5b^2$$

25.

$$\text{blue} = x \cdot y = xy$$

$$\text{yellow} = x \cdot z = xz$$

$$\text{total} = xy + xz + xz = xy + 2xz$$

26.

$$\text{red} = a \cdot b = ab$$

$$\text{green} = a \cdot a = a^2$$

$$\text{total} = a^2 + ab + ab + ab + ab = a^2 + 4ab$$

27.

$$\text{pink} = y \cdot 2x = 2xy$$

$$\text{white} = x \cdot x = x^2$$

$$\text{total} = 2xy - x^2 - x^2 = -2x^2 + 2xy$$

28. $2a + 2b - ab$

Mixed Review

$$29. \begin{cases} y = \frac{1}{3}x - 4 \\ y = -4x + 10 \end{cases} \approx (3, -3)$$

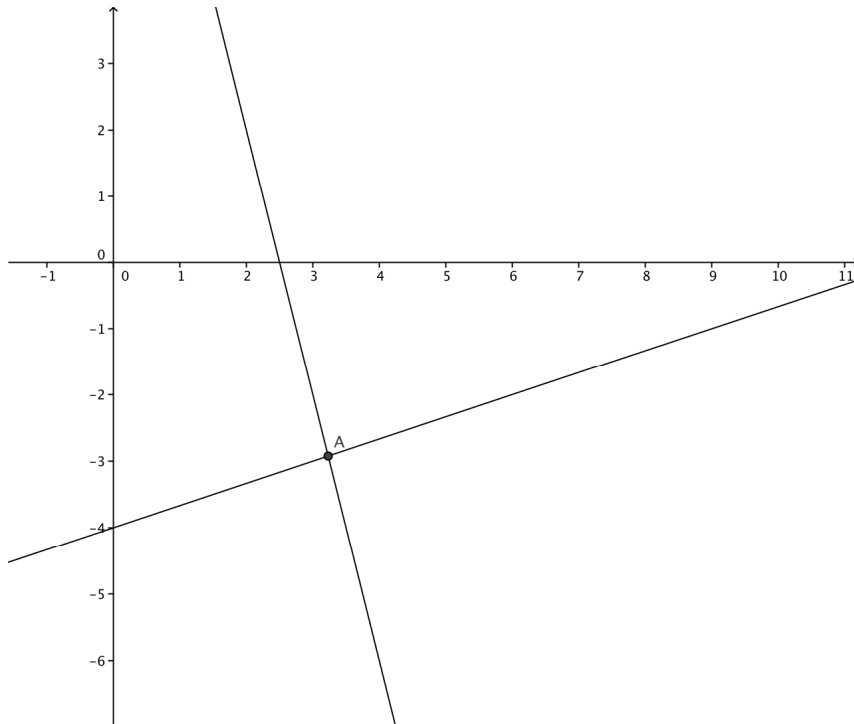

30.

$$12 = -\frac{4}{u}$$

$$12u = -4$$

$$u = -\frac{4}{12} = -\frac{1}{3}$$

31. $y = |x - 4| + 3$

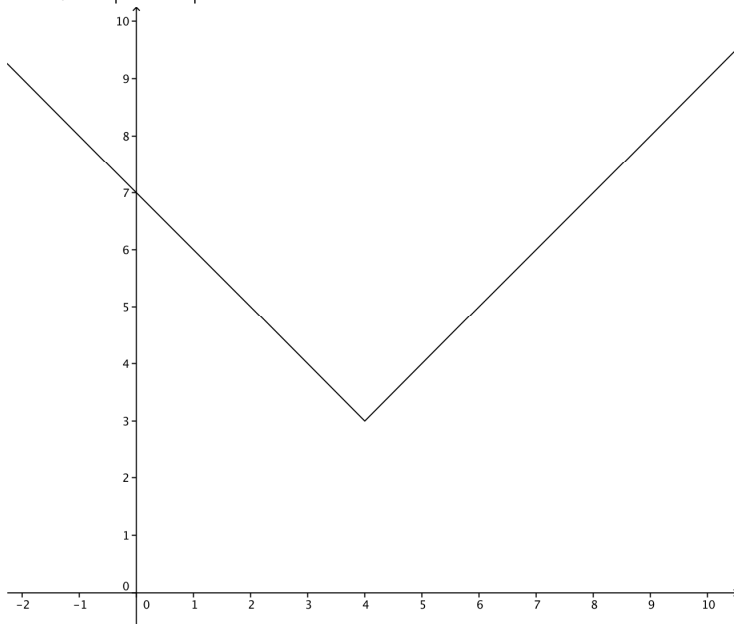

1. Domain = all real numbers

Range = all real numbers \geq 3

2. The graph has been shifted from the parent function up 3 spaces (+3) and 4 spaces to the right (-4).

32.

1. We have two regular 6-sided dice. We know that each die has the outcomes 1, 2, 3, 4, 5, or 6. We rolled both dice. We need to find the sample space.

The sample space is all possible outcomes of the event. In this example, the sample space is obtained from the sum of the numbers on both dice.

Possible outcomes are:

$$(1+1) = 2$$

$$(1+2) = (2+1) = 3$$

$$(2+3) = (3+2) = (1+4) = (4+1) = 5$$

$$(3+3) = (2+4) = (4+2) = (1+5) = (5+1) = 6$$

$$(3+4) = (4+3) = (2+5) = (5+2) = (1+6) = (6+1) = 7$$

$$(4+4) = (5+3) = (3+5) \dots\dots = 8$$

$$(5+4) = (4+5) \dots\dots\dots = 9$$

$$(6+4) = (4+6) \dots\dots\dots = 10$$

$$(5+6) = (6+5) \dots\dots\dots = 11$$

$$(6+6) = 12$$

We conclude that the sample space is $\{ 2, 3, 4, 5, 6, 7, 8, 9, 10, 11, 12 \}$

2. We know that all possible outcomes are $6*6 = 36$ possible outcomes.

We need to determine the possibility of getting a sum of 9.

To get a sum of 9 we need to get one of the following outcomes.

$$\implies (4+5), (5+4), (3+6), (6+3)$$

The total is 4 pairs.

The probability is $4/36 = 1/9$

33.

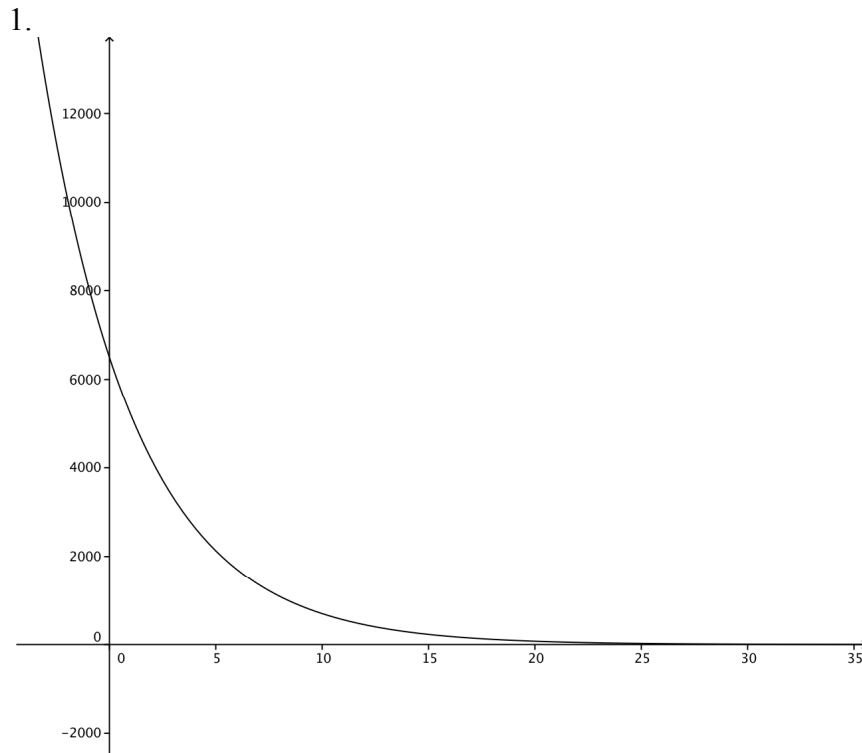

2. exponential decay

3. the initial value is 6500

4. Domain = all real numbers
Range = all positive real numbers

5.

$$y = 6500(0.8)^x$$

$$y = 6500(0.8)^{9.5}$$

$$y = 6500(.120047985437)$$

$$y = 780.311905343$$

34.

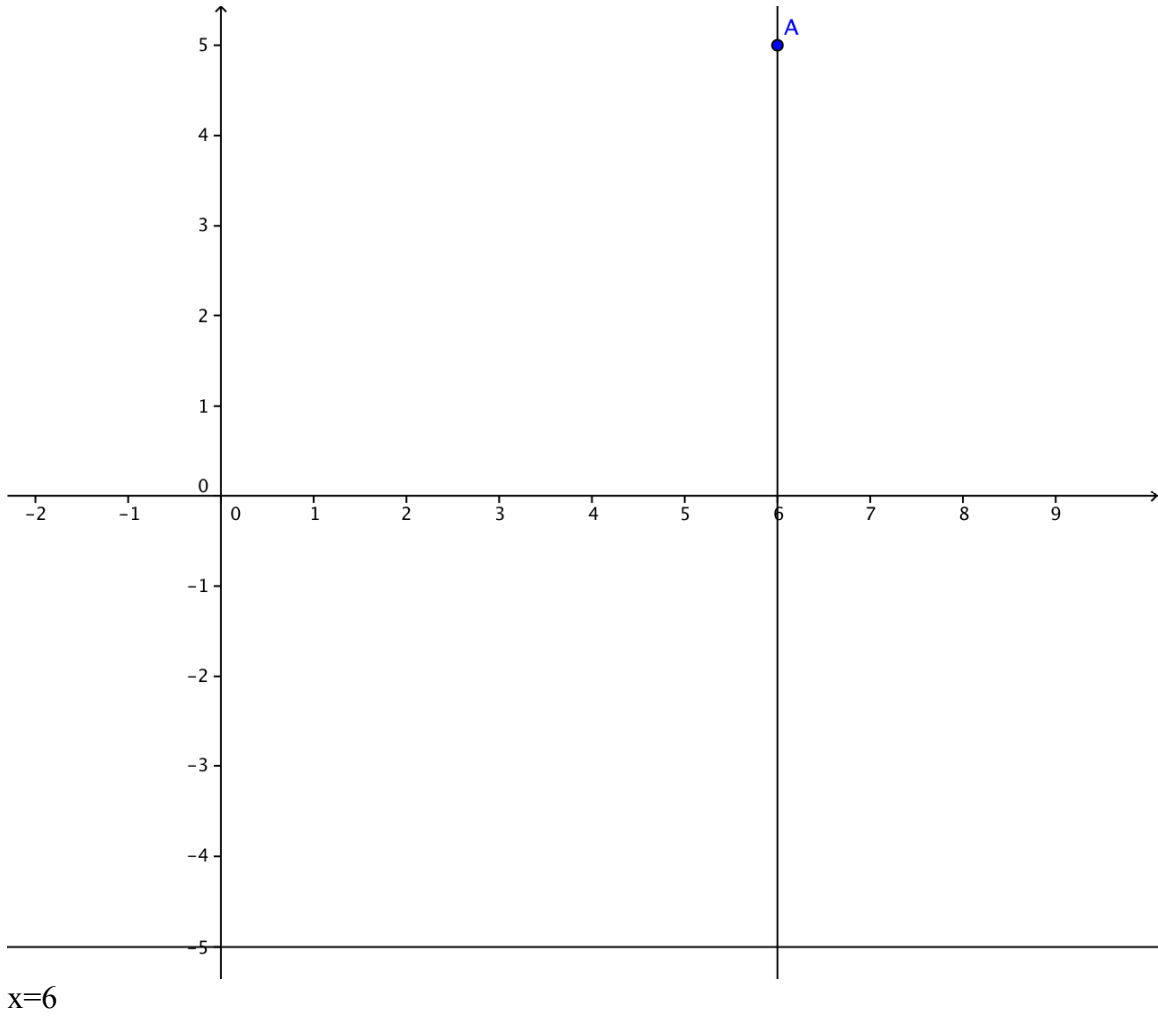

Lesson 9.2

Multiplication of Polynomials

$$1. (2x)(-7x) = -14x^2$$

$$2. 4(-6a) = -24a$$

$$3. (-5a^2b)(-12a^3b^3) = 60a^{2+3}b^{1+3} = 60a^5b^4$$

$$4. (-5x)(5y) = -25xy$$

$$5. y(xy^4) = x \cdot y^{4+1} = xy^5$$

$$6. (3xy^2z^2)(15x^2yz^3) = 45x^{1+2}y^{2+1}z^{2+3} = 45x^3y^3z^5$$

$$7. x^8(xy^3 + 3x) = x^{8+1}y^3 + 3x^{8+1} = x^9y^3 + 3x^9 = 4x^9y^3$$

$$8. 2x(4x - 5) = 8x^2 - 10x$$

$$9. 6ab(-10a^2b^3 + c^5) = -60a^{1+2}b^{1+3} + 6abc^5 = -60a^3b^4 + 6abc^5$$

$$10. 9x^3(3x^2 - 2x + 7) = 27x^{3+2} - 18x^{3+1} + 63x^3 = 27x^5 - 18x^4 + 63x^3$$

$$11. 3a^2b(9a^2 - 4b^2) = 27a^{2+2}b - 12a^2b^{1+2} = 27a^4b - 12a^2b^3$$

$$12. (x - 2)(x + 3) = x^2 + 3x - 2x - 6 = x^2 + x - 6$$

$$(a + 2)(2a)(a - 3)$$

$$13. (2a^2 + 4a)(a - 3)$$

$$2a^3 - 6a^2 + 4a^2 - 12a$$

$$2a^3 - 2a^2 - 12a$$

$$14. (-4xy)(2x^4yz^3 - y^4z^9) = -8x^5y^2z^3 + 4xy^5z^9$$

$$15. (x-3)(x+2) = x^2 + 2x - 3x - 6 = x^2 - x - 6$$

16.

$$(a^2 + 2)(3a^2 - 4)$$

$$3a^4 - 4a^2 + 6a^2 - 8$$

$$3a^4 + 2a^2 - 8$$

17.

$$(7x-2)(9x-5)$$

$$63x^2 - 35x - 18x + 10$$

$$63x^2 - 53x + 10$$

18.

$$(2x-1)(2x^2 - x + 3)$$

$$4x^3 - 2x^2 + 6x - 2x^2 + x - 3$$

$$4x^3 - 4x^2 + 7x - 3$$

19.

$$(3x+2)(9x^2 - 6x + 4)$$

$$27x^3 - 18x^2 + 12x + 18x^2 - 12x + 8$$

$$27x^3 + 8$$

20.

$$(a^2 + 2a - 3)(a^2 - 3a + 4)$$

$$(a^2 \cdot a^2) + (a^2 \cdot -3a) + (a^2 \cdot 4) + (2a \cdot a^2) + (2a \cdot -3a) + (2a \cdot 4) + (-3 \cdot a^2) + (-3 \cdot -3a) + (-3 \cdot 4)$$

$$a^4 - 3a^3 + 4a^2 + 2a^3 - 6a^2 + 8a - 3a^2 + 9a - 12$$

$$a^4 + (-3a^3 + 2a^3) + (4a^2 - 6a^2 - 3a^2) + (8a + 9a) - 12$$

$$a^4 - a^3 - 5a^2 + 17a - 12$$

21.

$$(3m + 1)(m - 4)(m + 5)$$

$$(3m^2 - 12m + m - 4)(m + 5)$$

$$(3m^2 - 11m - 4)(m + 5)$$

$$(3m^2 \cdot m) + (3m^2 \cdot 5) + (-11m \cdot m) + (-11m \cdot 5) + (-4 \cdot m) + (-4 \cdot 5)$$

$$3m^3 + 15m^2 - 11m^2 - 55m - 4m - 20$$

$$3m^3 + 4m^2 - 59m - 20$$

22.

$$\text{Volume} = (x^2 + 2x)(2x + 1)$$

$$\text{Volume} = (x^2 \cdot 2x) + (x^2 \cdot 1) + (2x \cdot 2x) + (2x \cdot 1)$$

$$\text{Volume} = 2x^3 + x^2 + 4x^2 + 2x$$

$$\text{Volume} = 2x^3 + 5x^2 + 2x$$

23. The base of the whole rectangle is $2x+4$

The height of the whole rectangle is $x+5$

$$A = b(h)$$

$$A = (2x + 4)(x + 5)$$

$$A = 2x^2 + 10x + 4x + 20$$

$$A = 2x^2 + 14x + 20$$

24.

First we have to find the area of the entire rectangle, including the missing piece.

The base = $3x$

The height = $x+x = 2x$

Now we find the area.

$$A = b(h)$$

$$A = 3x(2x)$$

$$A = 6x^2$$

$6x^2$ is the area of the entire rectangle WITH the missing piece. Now we have to find the area of that missing piece and subtract it from the overall area.

the base = $3x-8$

the height = x

$$A = b(h)$$

$$A = (3x - 8)x$$

$$A = 3x^2 - 8x$$

This is the area of the missing piece. Let's subtract.

$$6x^2 - (3x^2 - 8x)$$

$$6x^2 - 3x^2 + 8x$$

$$3x^2 + 8x$$

The area of the figure is $3x^2 + 8x$.

25.

$$V = l(w)(h)$$

$$l = 3x + 4$$

$$w = 2x$$

$$h = x + 1$$

$$V = (3x + 4)(2x)(x + 1)$$

$$V = (6x^2 + 8x)(x + 1)$$

$$V = 6x^3 + 6x^2 + 8x^2 + 8x$$

$$V = 6x^3 + 14x^2 + 8x$$

The volume of the figure is $6x^3 + 14x^2 + 8x$

26.

$$V = l(w)(h)$$

$$l = 2x + 4$$

$$w = 3x - 1$$

$$h = 4x$$

$$V = (2x + 4)(3x - 1)(4x)$$

$$V = (2x + 4)(12x^2 - 4x)$$

$$V = 24x^3 - 8x^2 + 48x^2 - 16x$$

$$V = 24x^3 + 40x^2 - 16x$$

The volume of the figure is $24x^3 + 40x^2 - 16x$

27. $n^4 + n^3 + n^2$

28.

Find the next four terms of the sequence 1, 3/2, 9/4, 27/8, ...

To find r we divide any term by the term in front of it : $3/2$ divided by $1 = 3/2$, $r=3/2$

Now we multiply to find the next four terms:

$$27/8 * 3/2 = \underline{81/16} * 3/2 = \underline{243/32} * 3/2 = \underline{729/64} * 3/2 = \underline{2187/128}$$

1, 3/2, 9/4, 27/8, 81/16, 243/32, 729/64, 2187/128...

29.

1.

Week (x)	Books read in the week	Total # of books (y)
0	3	3
1	3	6
2	3	9
3	3	12
4	3	15
5	3	18
6	3	21

2. The total # of books (y) is equal to the number of weeks (x) times the number of books read in that week (3) plus the initial 3 books.

$$y = 3x + 3$$

$$y = 3x + 3$$

$$63 = 3x + 3$$

3.

$$60 = 3x$$

$$x = 20$$

Reece will have read 63 books after week 20.

30. $0.062\% = .00062$

31.

$$ab\left(a + \frac{b}{4}\right)$$

$$a = 4$$

$$b = -3$$

$$4 \cdot -3\left(4 + \frac{-3}{4}\right) = -12\left(4 \frac{1}{4}\right) = -51$$

32.

$$3s(3 + 6s) + 6(5 + 3s)$$

$$9s + 18s^2 + 30 + 18s$$

$$18s^2 + 18s + 9s + 30$$

$$18s^2 + 27s + 30$$

Lesson 9.3

Special Products of Polynomials

$$1. (x + 9)^2 = x^2 + 2(x)(9) + 9^2 = x^2 + 18x + 81$$

$$2. (x - 1)^2 = x^2 - 2(x)(1) + 1^2 = x^2 - 2x + 1$$

$$3. (2y + 6)^2 = 4y^2 + 2(2y)(6) + 6^2 = 4y^2 + 24y + 36$$

$$4. (3x - 7)^2 = 9x^2 - 2(3x)(7) + 49 = 9x^2 - 42x + 49$$

$$5. (7c + 8)^2 = 49c^2 + 2(7c)(8) + 64 = 49c^2 + 112c + 64$$

$$6. (9a^2 + 6)^2 = 81a^4 + 2(9a^2)(6) + 36 = 81a^4 + 108a^2 + 36$$

$$7. (b^2 - 1)^2 = b^4 - 2(b^2)(1) + 1^2 = b^4 - 2b^2 + 1$$

$$8. (m^3 + 4)^2 = m^6 + 2(m^3)(4) + 4^2 = m^6 + 8m^3 + 16$$

$$9. \left(\frac{1}{4}t + 2\right)^2 = \frac{1}{16}t^2 + 2\left(\frac{1}{4}t\right)(2) + 2^2 = \frac{1}{16}t^2 + t + 4$$

$$10. (6k - 3)^2 = 36k^2 - 2(6k)(3) + 3^2 = 36k^2 - 36k + 9$$

$$11. (a^3 - 7)^2 = a^6 - 2(a^3)(7) + 49 = a^6 - 14a^3 + 49$$

$$12. (4x^2 + y^2)^2 = 16x^4 + 2(4x^2)(y^2) + y^4 = 16x^4 + 8x^2y^2 + y^4$$

$$13. (8x - 3)^2 = 64x^2 - 2(8x)(3) + 3^2 = 64x^2 - 48x + 9$$

$$14. (2x - 1)(2x + 1) = 4x^2 - 1$$

$$15. (2x - 3)(2x + 3) = 4x^2 - 9$$

$$16. (4 + 6x)(4 - 6x) = 16 - 36x^2$$

$$17. (6 + 2r)(6 - 2r) = 36 - 4r^2$$

$$18. (-2t + 7)(2t + 7) = (7 - 2t)(7 + 2t) = 49 - 4t^2$$

$$19. (8z - 8)(8z + 8) = 64z^2 - 64$$

$$20. (3x^2 + 2)(3x^2 - 2) = 9x^4 - 4$$

$$21. (x - 12)(x + 12) = x^2 - 144$$

$$22. (5a - 2b)(5a + 2b) = 25a^2 - 4b^2$$

$$23. (ab - 1)(ab + 1) = a^2b^2 - 1$$

$$24. (a - b)(a - b) = (a - b)^2 = a^2 - 2ab + b^2$$

$$25. 45 \times 55 = (50 - 5)(50 + 5) = 50^2 - 5^2 = 2500 - 25 = 2475$$

$$26. 97 \times 83 = (90 + 7)(90 - 7) = 90^2 - 7^2 = 8100 - 49 = 8051$$

$$27. 19^2 = (20 - 1)(20 - 1) = 20^2 - 2(20)(1) + 1^2 = 400 - 40 + 1 = 361$$

$$28. 56^2 = (50 + 6)(50 + 6) = 50^2 + 2(50)(6) + 6^2 = 2500 + 600 + 36 = 3136$$

$$29. 876 \times 924 = (900 - 24)(900 + 24) = 900^2 - 24^2 = 810000 - 576 = 809424$$

$$30. 1002 \times 998 = (1000 + 2)(1000 - 2) = 1000^2 - 2^2 = 1000000 - 4 = 999996$$

$$31. 36 \times 44 = (40 - 4)(40 + 4) = 40^2 - 4^2 = 1600 - 16 = 1584$$

Mixed Review

32.

$$5x(3x + 5) + 11(-7 - x)$$

$$15x^2 + 25x - 77 - 11x$$

$$15x^2 + 25x - 11x - 77$$

$$15x^2 + 14x - 77$$

33.

We don't know how many students are in the school overall, but we know the fractions for each class must add up to one: $\frac{1}{4} + \frac{2}{5} + \frac{1}{6} + ? = 1$. We don't know what fraction of the whole school are seniors so that is what we must find out first.

$$\frac{1}{4} + \frac{2}{5} + \frac{1}{6} + x = 1$$

$$\frac{15}{60} + \frac{24}{60} + \frac{10}{60} + x = 1$$

$$\frac{49}{60} + x = 1$$

$$x = 1 - \frac{49}{60} = \frac{60}{60} - \frac{49}{60} = \frac{11}{60}$$

$$x = \frac{11}{60}$$

We now know that the 130 seniors make up $\frac{11}{60}$ of the school. Let's use this information to figure out what the total population of the school is.

$$\frac{11}{60} = \frac{130}{x}$$

$$11x = 7800$$

$$x \approx 709$$

There are approximately 709 students in the whole school. Now we just need to calculate what $\frac{2}{5}$ (the percentage of sophomores) of 709 (the total number of students) is.

$$\frac{2}{5} \times 709 = \frac{1418}{5} \approx 284$$

There are approximately 284 students in the sophomore class.

34. $12! = 479001600$

35.

$$m(\text{slope}) = \frac{y_1 - y_2}{x_1 - x_2}$$

$$m = \frac{1 - (-16)}{\frac{3}{4} - \frac{3}{4}} = \frac{1 + 16}{0} = \frac{17}{0} = \text{undefined}$$

36.

First we convert the pounds to grams by multiplying.

$$260 * 454 = 118040 \text{ grams}$$

Now we must convert grams to kilograms. 1kg = 1000 grams

$$118040/1000 = 118.04 \text{ kg}$$

The person would weigh 118.04 kilograms.

$$37. |16 - v| = 3$$

$$(16 - v) = 3 \quad -(16 - v) = 3$$

$$-v = 3 - 16 \quad -16 + v = 3$$

$$-v = -13 \quad v = 3 + 16$$

$$v = 13$$

$$v = 19$$

$$v = 13, 19$$

38.

Yes this is a function, because for every x value there is only one possible y value.

Functions are defined as expressions where for each input there is only one output.

Lesson 9.4

Polynomial Equations in Factored Form

1. The *Zero Product Property* states that the only way for a product to be zero is for one or more of the terms being multiplied to be zero. Complex polynomials can be set equal to zero the factored, with each factor being set equal to zero, in order to solve the polynomial.

$$2. 36a^2 + 9a^3 - 6a^7 = 3a^2(12 + 3a - 2a^5)$$

$$3. 4x^3y^2 + 12x + 16y = 4(x^3y^2 + 3x + 4y)$$

$$4. 3x^3 - 21x = 3x(x^2 - 7)$$

$$5. 5x^6 + 15x^4 = 5x^4(x^2 + 3)$$

$$6. 4x^3 + 10x^2 - 2x = 2x(2x^2 + 5x - 1)$$

$$7. -10x^6 + 12x^5 - 4x^4 = 2x^4(-5x^2 + 6x - 2)$$

$$8. 12xy + 24xy^2 + 36xy^3 = 12xy(1 + 2y + 3y^2)$$

$$9. 5a^3 - 7a = a(5a^2 - 7)$$

$$10. 45y^{12} + 30y^{10} = 15y^{10}(3y^2 + 2)$$

$$11. 16xy^2z + 4x^3y = 4xy(4yz + x^2)$$

$$12. (x - 2)(x) = 2$$

The zero product property cannot be used because the equation is not set equal to zero. It is in the wrong format.

$$13. (x + 6) + (3x - 1) = 0$$

The zero product property does not apply when the two terms are being added, not multiplied.

$$14. (x^{-3})(x + 7) = 0$$

The zero product property cannot be applied because this is not a true polynomial (it has a negative exponent) and when $x=0$ the solution will be undefined.

$$15. (x + 9) - (6x - 1) = 4$$

The zero product property does not apply when the two terms are being subtracted, not multiplied.

$$16. (x^4)\left(\frac{1}{x^2} - 1\right) = 0$$

The zero product property cannot be applied because this is not a true polynomial (it has a variable in the denominator) and when $x=0$ the solution will be undefined.

$$17. x(x + 12) = 0$$

$$x = 0$$

$$x + 12 = 0$$

$$x = -12$$

Check

$$x(x + 12) = 0$$

$$0(0 + 12) = 0$$

$$0(12) = 0$$

$$0 = 0$$

$$x(x + 12) = 0$$

$$-12(-12 + 12) = 0$$

$$-12(0) = 0$$

$$0 = 0$$

$$18. (2x + 3)(5x - 4) = 0$$

$$2x + 3 = 0$$

$$2x = -3$$

$$x = -\frac{3}{2}$$

$$5x - 4 = 0$$

$$5x = 4$$

$$x = \frac{4}{5}$$

Check

$$(2x + 3)(5x - 4) = 0$$

$$\left(2\left(-\frac{3}{2}\right) + 3\right)\left(5\left(-\frac{3}{2}\right) - 4\right) = 0$$

$$(-3 + 3)\left(-\frac{15}{2} - 4\right) = 0$$

$$(0)\left(-\frac{7}{2}\right) = 0$$

$$0 = 0$$

$$(2x + 3)(5x - 4) = 0$$

$$\left(2\left(\frac{4}{5}\right) + 3\right)\left(5\left(\frac{4}{5}\right) - 4\right) = 0$$

$$\left(\frac{8}{5} + 3\right)(4 - 4) = 0$$

$$\left(\frac{23}{5}\right)(0) = 0$$

$$0 = 0$$

$$19. (2x + 1)(2x - 1) = 0$$

$$2x + 1 = 0$$

$$2x = -1$$

$$x = -\frac{1}{2}$$

$$2x - 1 = 0$$

$$2x = 1$$

$$x = \frac{1}{2}$$

Check

$$(2x + 1)(2x - 1) = 0$$

$$\left(2\left(-\frac{1}{2}\right) + 1\right)\left(2\left(-\frac{1}{2}\right) - 1\right) = 0$$

$$(-1 + 1)(-1 - 1) = 0$$

$$(0)(-2) = 0$$

$$0 = 0$$

$$(2x + 1)(2x - 1) = 0$$

$$\left(2\left(\frac{1}{2}\right) + 1\right)\left(2\left(\frac{1}{2}\right) - 1\right) = 0$$

$$(1 + 1)(1 - 1) = 0$$

$$(2)(0) = 0$$

$$0 = 0$$

20.

$$24x^2 - 4x = 0$$

$$4x(6x - 1) = 0$$

$$4x = 0$$

$$x = 0$$

$$6x - 1 = 0$$

$$6x = 1$$

$$x = \frac{1}{6}$$

Check

$$24x^2 - 4x = 0$$

$$24(0^2) - 4(0) = 0$$

$$24(0) - 0 = 0$$

$$0 - 0 = 0$$

$$0 = 0$$

$$24x^2 - 4x = 0$$

$$24\left(\frac{1}{6}\right)^2 - 4\left(\frac{1}{6}\right) = 0$$

$$24\left(\frac{1}{36}\right) - \frac{2}{3} = 0$$

$$\frac{2}{3} - \frac{2}{3} = 0$$

$$0 = 0$$

21.

$$60m = 45m^2$$

$$45m^2 = 60m$$

$$45m^2 - 60m = 0$$

$$15m(3m - 4) = 0$$

$$15m = 0$$

$$m = 0$$

$$3m - 4 = 0$$

$$3m = 4$$

$$m = \frac{4}{3}$$

Check

$$60m = 45m^2$$

$$60(0) = 45(0^2)$$

$$0 = 45(0)$$

$$0 = 0$$

$$60m = 45m^2$$

$$60\left(\frac{4}{3}\right) = 45\left(\frac{4}{3}\right)^2$$

$$80 = 45\left(\frac{16}{9}\right)$$

$$80 = 80$$

$$22. (x-5)(2x+7)(3x-4) = 0$$

$$x-5 = 0$$

$$x = 5$$

$$2x+7 = 0$$

$$2x = -7$$

$$x = -\frac{7}{2}$$

$$3x-4 = 0$$

$$3x = 4$$

$$x = \frac{4}{3}$$

Check

$$(x-5)(2x+7)(3x-4) = 0$$

$$(5-5)(2 \cdot 5 + 7)(3 \cdot 5 - 4) = 0$$

$$(0)(3)(11) = 0$$

$$0 = 0$$

$$(x-5)(2x+7)(3x-4) = 0$$

$$\left(\left(-\frac{7}{2}\right) - 5\right)\left(2 \cdot \left(-\frac{7}{2}\right) + 7\right)\left(3\left(-\frac{7}{2}\right) - 4\right) = 0$$

$$\left(-\frac{17}{2}\right)(0)\left(-\frac{29}{2}\right) = 0$$

$$0 = 0$$

$$(x-5)(2x+7)(3x-4) = 0$$

$$\left(\frac{4}{3} - 5\right)\left(2\left(\frac{4}{3}\right) + 7\right)\left(3\left(\frac{4}{3}\right) - 4\right) = 0$$

$$\left(-\frac{11}{3}\right)\left(\frac{29}{3}\right)(0) = 0$$

$$0 = 0$$

$$23. 2x(x + 9)(7x - 20) = 0$$

$$2x = 0$$

$$x = 0$$

$$x + 9 = 0$$

$$x = -9$$

$$7x - 20 = 0$$

$$7x = 20$$

$$x = \frac{20}{7}$$

Check

$$2x(x + 9)(7x - 20) = 0$$

$$2 \cdot 0(0 + 9)(7 \cdot 0 - 20) = 0$$

$$0(9)(-20) = 0$$

$$0 = 0$$

$$2x(x + 9)(7x - 20) = 0$$

$$2 \cdot -9(-9 + 9)(7(-9) - 20) = 0$$

$$-18(0)(-83) = 0$$

$$0 = 0$$

$$2x(x + 9)(7x - 20) = 0$$

$$2 \cdot \frac{20}{7} \left(\frac{20}{7} + 9 \right) \left(7 \cdot \frac{20}{7} - 20 \right) = 0$$

$$\frac{40}{7} \left(\frac{83}{7} \right) (0) = 0$$

$$0 = 0$$

24.

$$18y - 3y^2 = 0$$

$$3y(6 - y) = 0$$

$$3y = 0$$

$$y = 0$$

$$6 - y = 0$$

$$-y = -6$$

$$y = 6$$

Check

$$18y - 3y^2 = 0$$

$$18(0) - 3(0)^2 = 0$$

$$0 - 0 = 0$$

$$0 = 0$$

$$18y - 3y^2 = 0$$

$$18(6) - 3(6)^2 = 0$$

$$108 - 3(36) = 0$$

$$108 - 108 = 0$$

$$0 = 0$$

25.

$$9x^2 = 27x$$

$$9x^2 - 27x = 0$$

$$9x(x - 3) = 0$$

$$9x = 0$$

$$x = 0$$

$$x - 3 = 0$$

$$x = 3$$

Check

$$9x^2 = 27x$$

$$9(0)^2 = 27(0)$$

$$0 = 0$$

$$9x^2 = 27x$$

$$9(3)^2 = 27(3)$$

$$9(9) = 81$$

$$81 = 81$$

26.

$$4a^2 + a = 0$$

$$a(4a + 1) = 0$$

$$a = 0$$

$$4a + 1 = 0$$

$$4a = -1$$

$$a = -\frac{1}{4}$$

Check

$$4a^2 + a = 0$$

$$4(0)^2 + 0 = 0$$

$$0 + 0 = 0$$

$$0 = 0$$

$$4a^2 + a = 0$$

$$4\left(-\frac{1}{4}\right)^2 + \left(-\frac{1}{4}\right) = 0$$

$$4\left(\frac{1}{16}\right) - \frac{1}{4} = 0$$

$$\frac{1}{4} - \frac{1}{4} = 0$$

$$0 = 0$$

27.

$$b^2 - 3b = 0$$

$$b(b - 3) = 0$$

$$b = 0$$

$$b - 3 = 0$$

$$b = 3$$

Check

$$b^2 - 3b = 0$$

$$(0)^2 - 3(0) = 0$$

$$0 - 0 = 0$$

$$0 = 0$$

$$b^2 - 3b = 0$$

$$(3)^2 - 3(3) = 0$$

$$9 - 9 = 0$$

$$0 = 0$$

Mixed Review

28.

$$-4x + 11x^4 - 6x^7 + 1 - 3x^2$$

$$-6x^7 + 11x^4 - 3x^2 - 4x + 1$$

degree = 7

leadcoefficient = -6

29.

$$(9a^2 - 8a + 11a^3) - (3a^2 + 14a^5 - 12a) + (9 - 3a^5 - 13a)$$

$$9a^2 - 8a + 11a^3 - 3a^2 + 14a^5 + 12a + 9 - 3a^5 - 13a$$

$$-14a^5 - 3a^5 + 11a^3 + 9a^2 - 3a^2 - 8a + 12a - 13a + 9$$

$$-17a^5 + 11a^3 + 6a^2 - 17a + 9$$

$$\frac{1}{3}a^3 \times (36a^4 + 6)$$

30. $\left(\frac{1}{3} \cdot 36\right)(a^{3+4}) + \left(\frac{1}{3} \cdot 6\right)(a^{3+0})$

$$12a^7 + 2a^3$$

31.

1. $0.4x + 0.3y = 12$

2. To find the intercepts we first make $x=0$: $0.4(0)+0.3y=12$ which results in $y=40$. The y-intercept is $(0,40)$. Now we make $y=0$: $0.4x+0.3(0)=12$ which results in $x=30$. The x-intercept is $(30,0)$. Let's look at the graph.

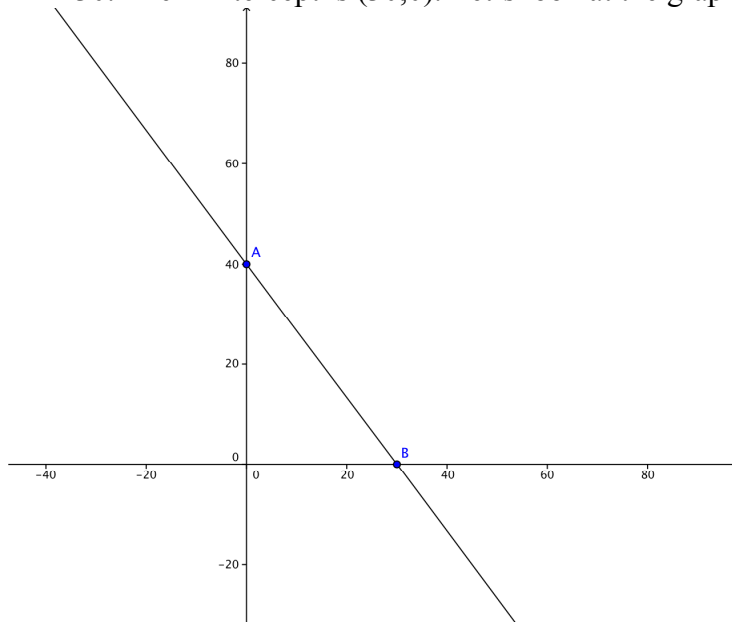

3. Three possible combinations to make this true: *Answers will vary, any point that falls along the line of the function or checks in the function is correct.*

32.

12.99 is almost 13.

13 is the same as $10 + 3$

8 times 10 is 80

8 times 3 is 24

Add these together and get 104.

Multiply .01 times 8 by moving the decimal two places to the left = 0.08

104 minus 0.08 is the same as $103 + 1 - 0.08 = 103 + 0.92 = 103.92$

Lesson 9.5
Factoring Quadratic Expressions

1. $x^2 + 10x + 9 = (x + 9)(x + 1)$

2. $x^2 + 15x + 50 = (x + 5)(x + 10)$

3. $x^2 + 10x + 21 = (x + 7)(x + 3)$

4. $x^2 + 16x + 48 = (x + 4)(x + 12)$

5. $x^2 - 11x + 24 = (x - 8)(x - 3)$

6. $x^2 - 13x + 42 = (x - 6)(x - 7)$

7. $x^2 - 14x + 33 = (x - 11)(x - 3)$

8. $x^2 - 9x + 20 = (x - 4)(x - 5)$

9. $x^2 + 5x - 14 = (x + 7)(x - 2)$

10. $x^2 + 6x - 27 = (x + 9)(x - 3)$

11. $x^2 + 7x - 78 = (x + 13)(x - 6)$

12. $x^2 + 4x - 32 = (x + 8)(x - 4)$

13. $x^2 - 12x - 45 = (x - 15)(x + 3)$

14. $x^2 - 5x - 50 = (x - 10)(x + 5)$

15. $x^2 - 3x - 40 = (x - 8)(x + 5)$

16. $x^2 - x - 56 = (x - 8)(x + 7)$

17. $-x^2 - 2x - 1 = -(x^2 + 2x + 1) = -(x + 1)(x + 1)$

18. $-x^2 - 5x + 24 = -(x^2 + 5x - 24) = -(x + 8)(x - 3)$

$$19. -x^2 + 18x - 72 = -(x^2 - 18x + 72) = -(x - 12)(x - 6)$$

$$20. -x^2 + 25x - 150 = -(x^2 - 25x + 150) = -(x + 30)(x - 5)$$

$$21. x^2 + 21x + 108 = (x + 9)(x + 12)$$

$$22. -x^2 + 11x - 30 = -(x^2 - 11x + 30) = -(x - 6)(x - 5)$$

$$23. x^2 + 12x - 64 = (x + 16)(x - 4)$$

$$24. x^2 - 17x - 60 = (x - 20)(x + 3)$$

Mixed Review

25.

$$f(x) = \frac{1}{2}x^2 - 6x + 4$$

$$f(2) = \frac{1}{2}(2)^2 - 6(2) + 4$$

$$f(2) = \frac{1}{2}(4) - 12 + 4$$

$$f(2) = 2 - 12 + 4$$

$$f(2) = -6$$

26.

1.

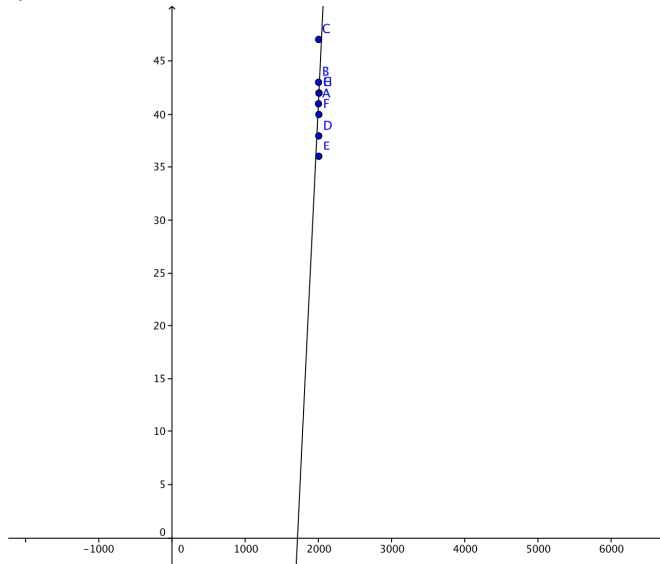

2. $x - 7y = 1715$

$$x - 7y = 1715$$

$$(2012) - 7y = 1715$$

$$-7y = 1715 - 2012$$

3. $-7y = -297$

$$y = -297 \div -7$$

$$y = 42.4285714286$$

$$y \approx 42$$

27. $\sqrt{405} = \sqrt{400 \cdot 5} = 20\sqrt{5}$

28.

$$A = -\pi$$

$$B = \sqrt{2}$$

$$C = \frac{5}{3}$$

$$D = -\frac{3}{10}$$

$$E = \sqrt{16}$$

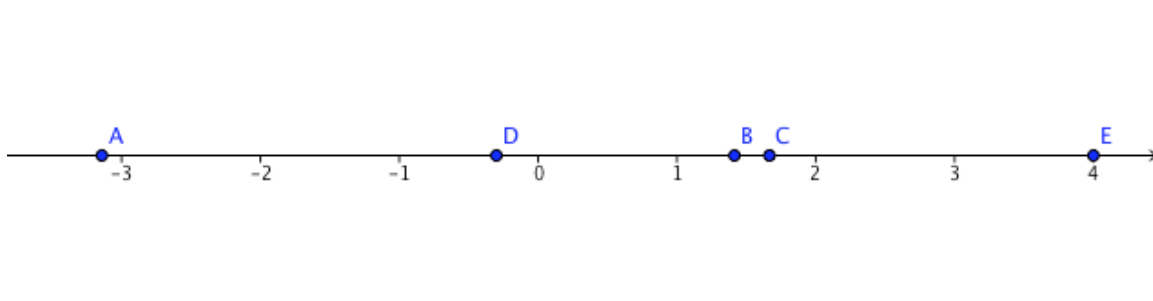

29. The multiplicative inverse of $9/4$ is $4/9$.

Quick Quiz

1.

$$6x^2y^4z + 6x^6 - 2y^5 + 11xyz^4$$

$$6x^2y^4z + 11xyz^4 + 6x^6 - 2y^5$$

$$\text{degree} = 7$$

$$\text{leading coefficient} = 6$$

2.

$$(a^2b^2c + 11abc^5) + (4abc^5 - 3a^2b^2c + 9abc)$$

$$a^2b^2c + 11abc^5 + 4abc^5 - 3a^2b^2c + 9abc$$

$$(11abc^5 + 4abc^5) + (a^2b^2c - 3a^2b^2c) + 9abc$$

$$15abc^5 - 2a^2b^2c + 9abc$$

3.

$$\text{Volume} = lwh$$

$$l = (a + 2)$$

$$w = (a + 4)$$

$$h = (3a)$$

$$V = (a + 2)(a + 4)(3a)$$

$$V = (a^2 + 4a + 2a + 8)(3a)$$

$$V = (a^2 + 6a + 8)(3a)$$

$$V = 3a^3 + 18a^2 + 24a$$

4. $-3hjk^3(h^2j^4k + 6hk^2) = -3h^3j^5k^4 - 18h^2jk^5$

5.

$$(x - 3)(x + 4)(2x - 1) = 0$$

$$x - 3 = 0$$

$$x = 3$$

$$x + 4 = 0$$

$$x = -4$$

$$2x - 1 = 0$$

$$2x = 1$$

$$x = \frac{1}{2}$$

Check

$$(x - 3)(x + 4)(2x - 1) = 0$$

$$(3 - 3)(3 + 4)(2(3) - 1) = 0$$

$$(0)(7)(5) = 0$$

$$0 = 0$$

$$(x - 3)(x + 4)(2x - 1) = 0$$

$$(-4 - 3)(-4 + 4)(2(-4) - 1) = 0$$

$$(-7)(0)(-9) = 0$$

$$0 = 0$$

$$(x - 3)(x + 4)(2x - 1) = 0$$

$$\left(\frac{1}{2} - 3\right)\left(\frac{1}{2} + 4\right)\left(2\left(\frac{1}{2}\right) - 1\right) = 0$$

$$\left(-2\frac{1}{2}\right)\left(4\frac{1}{2}\right)(0) = 0$$

$$0 = 0$$

$$6. (a - 9b)(a + 9b) = a^2 - 81b^2$$

Lesson 9.6**Factoring Special Products**

1. $x^2 + 8x + 16 = (x + 4)^2$

2. $x^2 - 18x + 81 = (x - 9)^2$

3. $-x^2 + 24x - 144 = -(x^2 - 24x + 144) = -(x - 12)^2$

4. $x^2 + 14x + 49 = (x + 7)^2$

5. $4x^2 - 4x + 1 = (2x - 1)^2$

6. $25x^2 + 60x + 36 = (5x + 6)^2$

7. $4x^2 - 12xy + 9y^2 = (2x - 3y)^2$

8. $x^4 + 22x^2 + 121 = (x^2 + 11)^2$

9. $x^2 - 4 = (x + 2)(x - 2)$

10. $x^2 - 36 = (x + 6)(x - 6)$

11. $-x^2 + 100 = 100 - x^2 = (10 + x)(10 - x)$

12. $x^2 - 400 = (x + 20)(x - 20)$

13. $9x^2 - 4 = (3x + 2)(3x - 2)$

14. $25x^2 - 49 = (5x + 7)(5x - 7)$

15. $-36x^2 + 25 = 25 - 36x^2 = (5 + 6x)(5 - 6x)$

16. $16x^2 - 81y^2 = (4x + 9y)(4x - 9y)$

17.

$$x^2 - 11x + 30 = 0$$

$$(x - 6)(x - 5) = 0$$

$$x - 6 = 0$$

$$x = 6$$

$$x - 5 = 0$$

$$x = 5$$

Check

$$x^2 - 11x + 30 = 0$$

$$(6)^2 - 11(6) + 30 = 0$$

$$36 - 66 + 30 = 0$$

$$-30 + 30 = 0$$

$$0 = 0$$

$$x^2 - 11x + 30 = 0$$

$$(5)^2 - 11(5) + 30 =$$

$$25 - 55 + 30 = 0$$

$$-30 + 30 = 0$$

$$0 = 0$$

18.

$$x^2 + 4x = 21$$

$$x^2 + 4x - 21 = 0$$

$$(x + 7)(x - 3) = 0$$

$$x + 7 = 0$$

$$x = -7$$

$$x - 3 = 0$$

$$x = 3$$

Check

$$x^2 + 4x = 21$$

$$(-7)^2 + 4(-7) = 21$$

$$49 - 28 = 21$$

$$21 = 21$$

$$x^2 + 4x = 21$$

$$(3)^2 + 4(3) = 21$$

$$9 + 12 = 21$$

$$21 = 21$$

19.

$$x^2 + 49 = 14x$$

$$x^2 - 14x + 49 = 0$$

$$(x - 7)^2 = 0$$

$$x - 7 = 0$$

$$x = 7$$

Check

$$x^2 + 49 = 14x$$

$$(7)^2 + 49 = 14(7)$$

$$49 + 49 = 98$$

$$98 = 98$$

20.

$$x^2 - 64 = 0$$

$$(x + 8)(x - 8) = 0$$

$$x + 8 = 0$$

$$x = -8$$

$$x - 8 = 0$$

$$x = 8$$

Check

$$x^2 - 64 = 0$$

$$(-8)^2 - 64 = 0$$

$$64 - 64 = 0$$

$$0 = 0$$

$$x^2 - 64 = 0$$

$$(-8)^2 - 64 = 0$$

$$64 - 64 = 0$$

$$0 = 0$$

21.

$$x^2 - 24x + 144 = 0$$

$$(x - 12)^2 = 0$$

$$x - 12 = 0$$

$$x = 12$$

Check

$$x^2 - 24x + 144 = 0$$

$$(12)^2 - 24(12) + 144 = 0$$

$$144 - 288 + 144 = 0$$

$$-144 + 144 = 0$$

$$0 = 0$$

22.

$$4x^2 - 25 = 0$$

$$(2x + 5)(2x - 5) = 0$$

$$2x + 5 = 0$$

$$2x = -5$$

$$x = -\frac{5}{2}$$

$$2x - 5 = 0$$

$$2x = 5$$

$$x = \frac{5}{2}$$

Check

$$4x^2 - 25 = 0$$

$$4\left(-\frac{5}{2}\right)^2 - 25 = 0$$

$$25 - 25 = 0$$

$$0 = 0$$

$$4x^2 - 25 = 0$$

$$4\left(\frac{5}{2}\right)^2 - 25 = 0$$

$$25 - 25 = 0$$

$$0 = 0$$

23.

$$x^2 + 26x = -169$$

$$x^2 + 26x + 169 = 0$$

$$(x + 13)^2 = 0$$

$$x + 13 = 0$$

$$x = -13$$

Check

$$x^2 + 26x = -169$$

$$(-13)^2 + 26(-13) = -169$$

$$169 - 338 = -169$$

$$-169 = -169$$

24.

$$-x^2 - 16x - 60 = 0$$

$$-(x^2 + 16x + 60) = 0$$

$$-(x + 6)(x + 10) = 0$$

$$-x - 6 = 0$$

$$-x = 6$$

$$x = -6$$

$$-x - 10 = 0$$

$$-x = 10$$

$$x = -10$$

Check

$$-x^2 - 16x - 60 = 0$$

$$-(-6)^2 - 16(-6) - 60 = 0$$

$$-36 + 96 - 60 = 0$$

$$-96 + 96 = 0$$

$$0 = 0$$

$$-x^2 - 16x - 60 = 0$$

$$-(-10)^2 - 16(-10) - 60 = 0$$

$$-100 + 160 - 60 = 0$$

$$60 - 60 = 0$$

$$0 = 0$$

Mixed Review

$$25. \begin{cases} 3x + 7y = 1 \\ kx - 14y = -2 \end{cases}$$

To make this system have an infinite number of solutions they must have the same slope and y-intercept. Let's change both equations to slope-intercept form ($y=mx+b$).

$$\begin{array}{l} 3x + 7y = 1 \\ 7y = 3x + 1 \\ y = \frac{3}{7}x + \frac{1}{7} \end{array} \qquad \begin{array}{l} kx - 14y = -2 \\ -14y = kx - 2 \\ y = \left(\frac{k}{-14}\right)x + \frac{2}{14} \\ y = \left(\frac{k}{-14}\right)x + \frac{1}{7} \end{array}$$

Now that they are both in slope-intercept form, we can see that they already have the same y-intercept. We need to make the slopes equal.

$$\begin{array}{l} \frac{k}{-14} = \frac{3}{7} \\ 7k = -42 \\ k = -6 \end{array}$$

When $k = -6$, then the system will have an infinite number of solutions.

$$26. \\ 2 * 3 * 4 = 24 \text{ possible combinations}$$

$$27. y - 5 = \frac{1}{3}(x + 4)$$

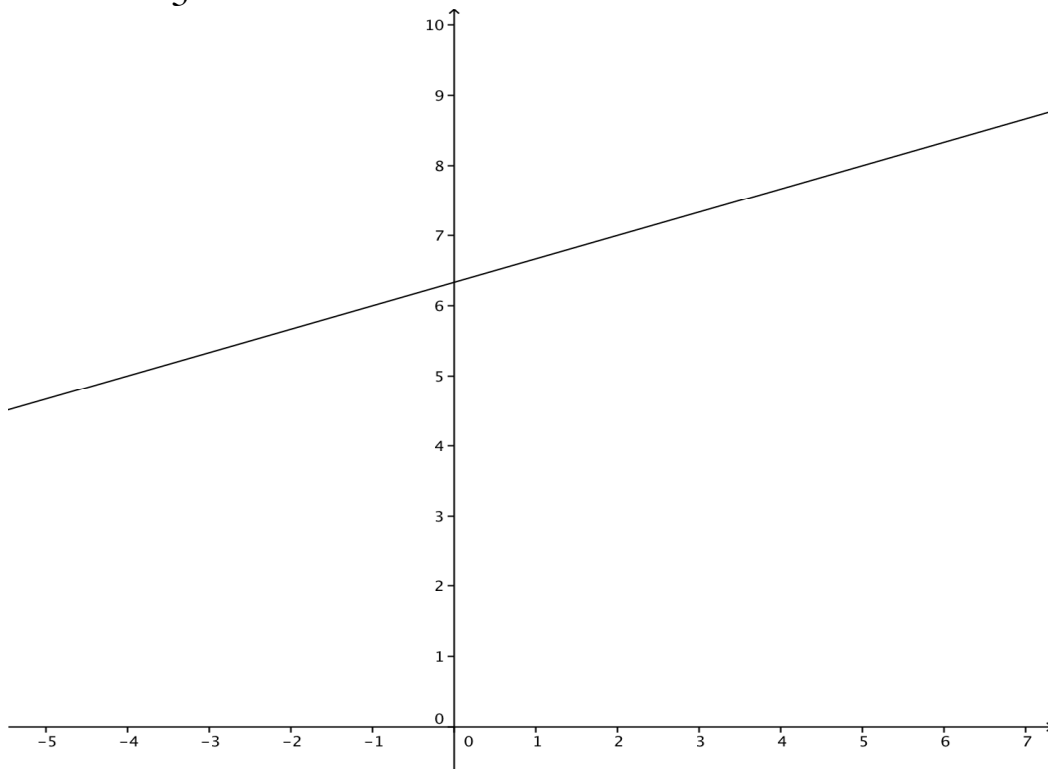

$$y - 5 = \frac{1}{3}(x + 4)$$

$$y - 5 = \frac{1}{3}x + \frac{4}{3}$$

$$y = \frac{1}{3}x + \frac{4}{3} + 5$$

$$y = \frac{1}{3}x + 6\frac{1}{3}$$

The slope is $\frac{1}{3}$.

28.

1.

$$y = a(b)^x$$

$$a = 600$$

$$b = 100\% + 8\% = 1.08$$

$$y = 600(1.08)^x$$

2.

$$y = 600(1.08)^x$$

$$y = 600(1.08)^6$$

$$y = 600(1.58687432294)$$

$$y = 952.124593766$$

$$y \approx \$952.13$$

29.

$$4\frac{8}{9} \div -3\frac{1}{5}$$

$$\frac{44}{9} \div -\frac{16}{5}$$

$$\frac{44}{9} \times -\frac{5}{16} = -\frac{55}{36} = -1\frac{19}{36}$$

30. Any number that is negative and divisible by 2 would be a correct answer.

Lesson 9.7

Factoring Polynomials Completely

1.

$$2x^2 + 16x + 30$$

$$2(x^2 + 8x + 15)$$

$$2(x + 5)(x + 3)$$

2.

$$12c^2 - 75$$

$$3(4c^2 - 25)$$

$$3(2cx - 5)(2c + 5)$$

3.

$$-x^3 + 17x^2 - 70x$$

$$-x(x^2 - 17x + 70)$$

$$-x(x - 10)(x - 7)$$

4.

$$6x^2 - 600$$

$$6(x^2 - 100)$$

$$6(x + 10)(x - 10)$$

5.

$$-5t^2 - 20t - 20$$

$$-5(t^2 + 4t + 4)$$

$$-5(t+2)(t+2)$$

6.

$$6x^2 + 18x - 24$$

$$6(x^2 + 3x - 4)$$

$$6(x+4)(x-1)$$

7.

$$-n^2 + 10n - 21$$

$$-(n^2 - 10n + 21)$$

$$-(n-7)(n-3)$$

8.

$$2a^2 - 14a - 16$$

$$2(a^2 - 7a - 8)$$

$$2(a-8)(a+1)$$

9.

$$2x^2 - 512$$

$$2(x^2 - 256)$$

$$2(x + 16)(x - 16)$$

10.

$$12x^3 + 12x^2 + 3x$$

$$3x(4x^2 + 4x + 1)$$

$$3x(2x + 1)(2x + 1)$$

11.

$$6x^2 - 9x + 10x - 15$$

$$(6x^2 - 9x) + (10x - 15)$$

$$3x(2x - 3) + 5(2x - 3)$$

$$(3x + 5)(2x - 3)$$

12.

$$5x^2 - 35x + x - 7$$

$$(5x^2 - 35x) + (x - 7)$$

$$5x(x - 7) + (x - 7)$$

$$(5x + 1)(x - 7)$$

13.

$$9x^2 - 9x - x + 1$$

$$(9x^2 - 9x) + (-x + 1)$$

$$9x(x - 1) - (x - 1)$$

$$(9x - 1)(x - 1)$$

14.

$$4x^2 + 32x - 5x - 40$$

$$(4x^2 + 32x) + (-5x - 40)$$

$$4x(x + 8) - 5(x + 8)$$

$$(4x - 5)(x + 8)$$

15.

$$12x^3 - 14x^2 + 42x - 49$$

$$(12x^3 - 14x^2) + (42x - 49)$$

$$2x^2(6x - 7) + 7(6x - 7)$$

$$(2x^2 + 7)(6x - 7)$$

16.

$$4x^2 + 25x - 21$$

$$4x^2 + 28x - 3x - 21$$

$$(4x^2 + 28x) + (-3x - 21)$$

$$4x(x + 7) - 3(x + 7)$$

$$(4x - 3)(x + 7)$$

17.

$$24b^3 + 32b^2 - 3b - 4$$

$$(24b^3 + 32b^2) + (-3b - 4)$$

$$8b^2(3b + 4) - (3b + 4)$$

$$(8b^2 - 1)(3b + 4)$$

18.

$$2m^3 + 3m^2 + 4m + 6$$

$$(2m^3 + 3m^2) + (4m + 6)$$

$$m^2(2m + 3) + 2(2m + 3)$$

$$(m^2 + 2)(2m + 3)$$

19.

$$6x^2 + 7x + 1$$

$$6x^2 + 6x + x + 1$$

$$(6x^2 + 6x) + (x + 1)$$

$$6x(x + 1) + (x + 1)$$

$$(6x + 1)(x + 1)$$

20.

$$4x^2 + 8x - 5$$

$$4x^2 + 10x - 2x - 5$$

$$(4x^2 + 10x) + (-2x - 5)$$

$$2x(2x + 5) - (2x + 5)$$

$$(2x - 1)(2x + 5)$$

21.

$$5a^3 - 5a^2 + 7a - 7$$

$$(5a^3 - 5a^2) + (7a - 7)$$

$$5a^2(a - 1) + 7(a - 1)$$

$$(5a^2 + 7)(a - 1)$$

22.

$$3x^2 + 16x + 21$$

$$3x^2 + 9x + 7x + 21$$

$$(3x^2 + 9x) + (7x + 21)$$

$$3x(x + 3) + 7(x + 3)$$

$$(3x + 7)(x + 3)$$

23.

$$4xy + 32x + 20y + 160$$

$$(4xy + 32x) + (20y + 160)$$

$$4x(y + 8) + 20(y + 8)$$

$$(4x + 20)(y + 8)$$

$$(4(x + 5))(y + 8)$$

24.

$$10ab + 40a + 6b + 24$$

$$2(5ab + 20a + 3b + 12)$$

$$2(5ab + 20a) + (3b + 12)$$

$$2 \cdot 5a(b + 4) + 3(b + 4)$$

$$2(5a + 3)(b + 4)$$

25.

$$9mn + 12m + 3n + 4$$

$$(9mn + 12m) + (3n + 4)$$

$$3m(3n + 4) + (3n + 4)$$

$$(3m + 1)(3n + 4)$$

26.

$$\begin{aligned} &4jk - 8j^2 + 5k - 10j \\ &(4jk - 8j^2) + (5k - 10j) \\ &4j(k - 2j) + 5(k - 2j) \\ &(4j + 5)(k - 2j) \end{aligned}$$

27.

$$\begin{aligned} &24ab + 64a - 21b - 56 \\ &(24ab + 64a) + (-21b - 56) \\ &8a(3b + 8) - 7(3b + 8) \\ &(8a - 7)(3b + 8) \end{aligned}$$

28.

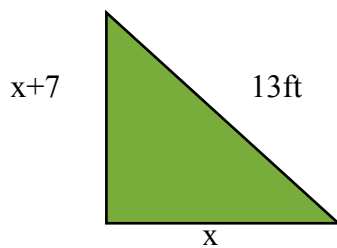

We can use the Pythagorean theorem ($a^2 + b^2 = c^2$ where c is the hypotenuse) to figure out the value of x and the length of the sides.

$$a^2 + b^2 = c^2$$

$$x^2 + (x + 7)^2 = 13^2$$

$$x^2 + x^2 + 14x + 49 = 169$$

$$2x^2 + 14x + 49 = 169$$

$$2x^2 + 14x + 49 - 169 = 0$$

$$2x^2 + 14x - 120 = 0$$

$$2(x^2 + 7x - 60) = 0$$

$$2 \cdot (x + 12)(x - 5) = 0$$

$$2(x + 12) = 0$$

$$2x + 24 = 0$$

$$2x = -24$$

$$~~x = -12~~$$

$$2(x - 5) = 0$$

$$2x - 10 = 0$$

$$2x = 10$$

$$x = 5$$

$$x = 5$$

$$x + 7 = 12$$

$$a^2 + b^2 = c^2$$

Check: $5^2 + 12^2 = 13^2$

$$25 + 144 = 169$$

$$169 = 169$$

The length of the three sides are 5ft, 12ft, and 13 ft.

29.

$$A = l(w)$$

$$l = x + 2$$

$$w = x - 1$$

$$A = 108$$

$$(x + 2)(x - 1) = 108$$

$$x^2 - x + 2x - 2 - 108 = 0$$

$$x^2 + x - 110 = 0$$

$$(x + 11)(x - 10) = 0$$

$$x + 11 = 0$$

$$~~x = -11~~$$

$$x - 10 = 0$$

$$x = 10$$

Check:

$$(x + 2)(x - 1) = 108$$

$$(10 + 2)(10 - 1) = 108$$

$$(12)(9) = 108$$

$$108 = 108$$

When $x=5$ then the Area of the triangle is 108.

30.

$$x(x + 7) = 120$$

$$x^2 + 7x - 120 = 0$$

$$(x + 15)(x - 8) = 0$$

$$x + 15 = 0$$

$$~~x = -15~~$$

$$x - 8 = 0$$

$$x = 8$$

The two numbers are 8 and 15.

31. We need to find the maximum size picture to frame for \$20.

Let the side of the picture be x ft.

We know that the total cost will be:

Total cost = cost of glass + cost of frame

Cost of glass = \$1 per sq ft.

Cost of frame = \$2 per ft.

$$\text{glass} = 1 \cdot \text{area} = 1 \cdot x \cdot x = x^2$$

$$\text{frame} = 2 \cdot \text{perimeter} = 2 \cdot 4x = 8x$$

$$\text{Cost} = x^2 + 8x$$

Now we will find the length of the side x if the cost is 20 dollars.

$$x^2 + 8x = \$20$$

$$x^2 + 8x - 20 = 0$$

$$(x + 10)(x - 2) = 0$$

$$x + 10 = 0$$

$$~~x = -10~~$$

$$x - 2 = 0$$

$$x = 2$$

A picture with the dimensions 2 ft x 2 ft will cost 20 dollars to frame.

32.

1) The area of a square is equal to length times width. Since the length and width of a square are equal then Area of a square is equal to the side squared. If s equals the side then $A(s) = s^2$.

2) Given $s = 1.5$

$$A(s) = s^2$$

$$A(1.5) = (1.5)^2$$

$$A(1.5) = 2.25$$

The area is 2.25 sq ft.

33.

$$SA = 2\pi r^2 + 2\pi rh$$

$$r = 2$$

$$h = 5.5$$

$$SA = 2(3.14)(2^2) + 2(3.14)(2)(5.5)$$

$$SA = (6.28)(4) + (6.28)(2)(5.5)$$

$$SA = (25.12) + (12.56)(5.5)$$

$$SA = 25.12 + 69.08$$

$$SA = 94.2$$

The surface area of the soup can is 94.2 inches.

34.

$$25g^2 - 36$$

$$(5g + 6)(5g - 6)$$

$$(5g + 6)(5g - 6) = 0$$

$$5g + 6 = 0$$

$$5g = -6$$

$$g = -\frac{6}{5} = -1\frac{1}{5}$$

$$5g - 6 = 0$$

$$5g = 6$$

$$g = \frac{6}{5} = 1\frac{1}{5}$$

35.

$$343r^3t = 7t(49r^3)$$

$$21t^4 = 7t(3t^3)$$

$$63rt^5 = 7t(9rt^4)$$

The greatest common factor is $7t$.

36. Since discounts start with groups more than 12 people, a discount will be given to groups that have 13 or more people in them.

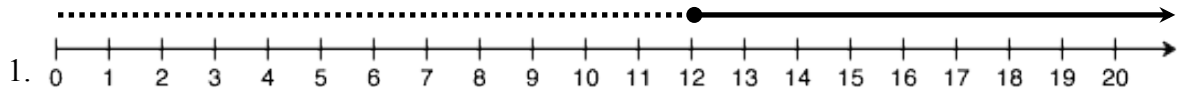

2. The domain of the problem is the set of natural numbers. Since there cannot be negative amount of people in a group and there has to be at least one person, the domain is $\{1, 2, 3, 4, 5, \dots\}$. When people are a part of the solution, fractions or decimals are not considered. You wouldn't consider a group with 15.5 people in it.

3. The church group with exactly 12 members will not get a discount. The problem specifically states groups with more than 12 people.

Lesson 9.8

Probability of Compound Events

1. *Independent events* are occurrences where the outcome of the second event is not affected by the outcome of the first event.

2. Independent

3. Dependent

4. Independent

5. Independent

6.

$$P(A \cap B) = P(A) \times P(B)$$

$$P(A) = \frac{1}{6}$$

$$P(B) = \frac{1}{6}$$

$$P(A \cap B) = \frac{1}{6} \times \frac{1}{6} = \frac{1}{36}$$

(events are Independent)

7. *Mutually exclusive* is when two events cannot happen at the same time.

8. mutually exclusive

9. mutually inclusive

10. mutually inclusive

11. mutually exclusive

12. mutually inclusive

13. mutually exclusive

14.

(a) P(heart or club)

In terms of the formula $P(A \text{ or } B) = P(A) + P(B) - P(A \text{ and } B)$

$P(\text{heart or club}) = P(\text{heart}) + P(\text{club}) - P(\text{heart and club})$

$$13 \cdot \frac{12}{52} \cdot \frac{1}{51} + 13 \cdot \frac{12}{52} \cdot \frac{1}{51} - 0 = \frac{2}{17}$$

(b) P(heart and club)

In terms of the formula $P(A \text{ and } B) = P(A) \cdot P(B)$

$P(\text{heart and club}) = P(\text{heart}) \cdot P(\text{club})$

$$(13 \cdot \frac{12}{52} \cdot \frac{1}{51}) \cdot (13 \cdot \frac{12}{52} \cdot \frac{1}{51}) = \frac{1}{289}$$

(c) P(red or heart)

In terms of the formula $P(A \text{ or } B) = P(A) + P(B) - P(A \text{ and } B)$

$P(\text{red or heart}) = P(\text{red}) + P(\text{heart}) - P(\text{red and heart})$

$$26 \cdot \frac{25}{52} \cdot \frac{1}{51} + 13 \cdot \frac{12}{52} \cdot \frac{1}{51} - 13 \cdot \frac{12}{52} \cdot \frac{1}{51} = \frac{26 \cdot 25}{52 \cdot 51} = \frac{25}{102}$$

(d) P(jack or heart)

In terms of the formula $P(A \text{ or } B) = P(A) + P(B) - P(A \text{ and } B)$

$P(\text{jack or heart}) = P(\text{jack}) + P(\text{heart}) - P(\text{jack and heart})$

$$4 \cdot \frac{3}{52} \cdot \frac{1}{51} + 13 \cdot \frac{12}{52} \cdot \frac{1}{51} - 1 \cdot \frac{0}{52} \cdot \frac{1}{51} = \frac{14}{221}$$

(e) P(red or ten)

In terms of the formula $P(A \text{ or } B) = P(A) + P(B) - P(A \text{ and } B)$

$P(\text{red or ten}) = P(\text{red}) + P(\text{ten}) - P(\text{red and ten})$

$$26 \cdot \frac{25}{52} \cdot \frac{1}{51} + 4 \cdot \frac{3}{52} \cdot \frac{1}{51} - 2 \cdot \frac{1}{52} \cdot \frac{1}{51} = \frac{55}{221}$$

(f) P(red queen or black jack)

In terms of the formula $P(A \text{ or } B) = P(A) + P(B) - P(A \text{ and } B)$

$P(\text{red queen or black jack}) = P(\text{red queen}) + P(\text{black jack}) - P(\text{red queen and black jack})$

$$2 \cdot \frac{1}{52} \cdot \frac{1}{51} + 2 \cdot \frac{1}{52} \cdot \frac{1}{51} - 0 = \frac{1}{663}$$

15.

$$P(A) = \frac{5}{13}$$

$$P(B) = \frac{8}{12} = \frac{2}{3}$$

$$P(A \cap B) = \frac{5}{13} \cdot \frac{2}{3} = \frac{10}{39}$$

$$16. P = \frac{5}{15} \cdot \frac{4}{14} \cdot \frac{6}{13} \cdot \frac{4}{12} \cdot \frac{3}{11} = \frac{1440}{360360} = \frac{4}{1001}$$

17. Common sense tells us that there are 2 cards in the deck that are both black and 7, therefore the probability is $2/52$ or $1/26$. We can also find the answer using the formula.

$$P(A \cap B) = P(A) \cdot P(B)$$

$$P(A) = P(\text{black}) = \frac{26}{52}$$

$$P(B) = P(7) = \frac{4}{52}$$

$$P(A \cap B) = \frac{26}{52} \cdot \frac{4}{52} = \frac{2}{52} = \frac{1}{26}$$

Mixed Review

18.

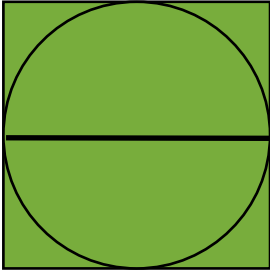

$$\text{Area of a square} = s^2$$

$$\text{Area of a circle} = \pi r^2$$

$$A(\text{square}) = 16^2 = 256$$

$$A(\text{circle}) = \pi \cdot 8^2 = (3.14)(64) = 200.96$$

$$\text{Difference} = 256 - 200.96 = 55.04$$

$$\frac{55.04}{256} = \frac{x}{100}$$

$$5504 = 256x$$

$$x = 21.5$$

The probability of hitting the area inside the square but outside the circle is 55.04 out of 256, or 21.5 %.

19. $7 - 14x^4 + 7xy^5 - 1x^{-1} = 8x^2y^3$ is not a polynomial because it has a negative exponent and is not set equal to zero.

$$72b^5m^3w^9 - 6(bm)^2w^6$$

20. $72b^5m^3w^9 - 6b^2m^2w^6$

$$6b^2m^2w^6(12b^3mw^3 - 1)$$

$$2^5 - 7^3a^3b^7 + 3^5a^3b^7 - 2^3$$

21. $32 - 343a^3b^7 + 243a^3b^7 - 8$

$$24 - 100a^3b^7$$

22.

$$y = a(b)^x$$

1. $y = 100(1 - 0.125)^w$

$$y = 100(0.875)^w$$

$$y = 100(0.875)^{11}$$

2. $y = 100(.23019)$ There will be 23% left after 11 washes

$$y = 23$$

3. In order to figure out when the shirt has 75% left, we must make a table of values.

w	$100(0.875)^w$	y
2	$100(0.875)^2 = 100 * 0.765625$ $= 76.5625$	$76.5625 = 77$
3	$100(0.875)^3 = 100 * 0.669921$ $875 = 66.9921875$	$66.99 = 67$

We can already see that the answer will be between 2 and 3. Let's make another table.

w	$100(0.875)^w$	y
2.1	$100(0.875)^{2.1} = 100 * 0.75554$ $69457836 = 75.5546945$	$75.554 = 76$
2.2	$100(0.875)^{2.2} = 100 * 0.74544$ $8622658 = 74.5448622658$	$74.544 = 75$

This gives us the answer as approximately equal to 2.2. The exact answer is between 2.1 and 2.2.

23.

$$\frac{(100 \div 4 \times 2 - 49)^2}{9 - 2 \times 3 + 2^2}$$

$$\frac{(25 \times 2 - 49)^2}{9 - 2 \times 3 + 2^2}$$

$$\frac{(50 - 49)^2}{9 - 2 \times 3 + 2^2}$$

$$\frac{1^2}{9 - 2 \times 3 + 2^2}$$

$$\frac{1}{9 - 2 \times 3 + 2^2}$$

$$\frac{1}{9 - 2 \times 3 + 4}$$

$$\frac{1}{9 - 6 + 4}$$

$$\frac{1}{3 + 4}$$

$$\frac{1}{7}$$

Lesson 9.9

Chapter 9 Review

1. A *Polynomial* is an expression made with constants, variables and positive integer exponents of the variables.
2. A *Monomial* is a polynomial with only one term.
3. A *Trinomial* is a polynomial with three terms.
4. A *Binomial* is a polynomial with two terms.
5. A *Coefficient* is the number that appears before the variable(s) in each term of a polynomial.
6. *Independent Events* are occurrences in which the outcome of the first event does not effect the outcome of the events that follow.
7. *Factors* are terms that are multiplied to create a product.
8. *Factoring* is the process by which one breaks down an expression into its factors or multipliers.

9. The *Greatest Common Factor* is the largest number or term by which a group of terms can all be evenly divided.

10. A *Constant* is a number in a polynomial that is not followed by a variable.

12. *Dependent events* are occurrences where the outcome of the first event effects the outcome of the events that follow.

13.

$$x^5 - 3x^3 + 4x^2 - 5x + 7$$

coefficients : 1, -3, 4, -5

constant : 7

degrees : 5(3,2,1)

14.

$$x^4 - 3x^3y^2 + 8x - 12$$

coefficients : 1, -3, 8

constant : -12

degrees : 5(4,1)

15. $-4b + 4 + b^2 = b^2 - 4b + 4$

16. $3x^2 + 5x^4 - 2x + 9 = 5x^4 + 3x^2 - 2x + 9$

17.

$$(x^2 - 2xy + y^2) + (2y^2 - 4x^2) + (10xy + y^3)$$

$$x^2 - 2xy + y^2 + 2y^2 - 4x^2 + 10xy + y^3$$

$$(x^2 - 4x^2) + (-2xy + 10xy) + (y^2 + 2y^2) + y^3$$

$$-3x^2 + 8xy + 3y^2 + y^3$$

$$y^3 + 3y^2 - 3x^2 + 8xy$$

18.

$$\begin{aligned} & (4x^2 + 5x - 9) - (x^3 - 3x^2 + 8x + 12) \\ & 4x^2 + 5x - 9 - x^3 + 3x^2 - 8x - 12 \\ & (4x^2 + 3x^2) + (5x - 8x) + (-9 - 12) - x^3 \\ & 7x^2 - 3x - 21 - x^3 \\ & -x^3 + 7x^2 - 3x - 21 \end{aligned}$$

19.

$$\begin{aligned} & (2x^3 + 3x^2y + 2y) + (x^3 - 2x^2y + 3y) \\ & 2x^3 + 3x^2y + 2y + x^3 - 2x^2y + 3y \\ & (2x^3 + x^3) + (3x^2y - 2x^2y) + (2y + 3y) \\ & 3x^3 + x^2y + 5y \end{aligned}$$

$$20. (-3y^4)(2y^2) = -6y^{4+2} = -6y^6$$

21.

$$\begin{aligned} & -7a^2bc^3(5a^2 - 3b^2 - 9c^2) \\ & -35a^{2+2}bc^3 + 21a^2b^{2+1}c^3 + 63a^2bc^{3+2} \\ & -35a^4bc^3 + 21a^2b^3c^3 + 63a^2bc^5 \end{aligned}$$

22.

$$\begin{aligned} & -7y(4y^2 - 2y + 1) \\ & -28y^{1+2} + 14y^{1+1} - 7y \\ & -28y^3 + 14y^2 - 7y \end{aligned}$$

23.

$$\begin{aligned} & (3x^2 + 2x - 5)(2x - 3) \\ & (3x^2 \cdot 2x) + (3x^2 \cdot -3) + (2x \cdot 2x) + (2x \cdot -3) + (-5 \cdot 2x) + (-5 \cdot -3) \\ & 6x^3 - 9x^2 + 4x^2 - 6x - 10x + 15 \\ & 6x^3 - 5x^2 - 16x + 15 \end{aligned}$$

24.

$$\begin{aligned} & (x^2 - 9)(4x^4 + 5x^2 - 2) \\ & (x^2 \cdot 4x^4) + (x^2 \cdot 5x^2) + (x^2 \cdot -2) + (-9 \cdot 4x^4) + (-9 \cdot 5x^2) + (-9 \cdot -2) \\ & 4x^6 + 5x^4 - 2x^2 - 36x^4 - 45x^2 + 18 \\ & 4x^6 - 31x^4 - 47x^2 + 18 \end{aligned}$$

$$\begin{aligned} 25. & (2x^3 + 7)(2x^3 - 7) \\ & 4x^6 - 49 \end{aligned}$$

(The factors tell us that the answer will be the difference of two squares, so we can eliminate the middle terms.)

26.

$$\begin{aligned} & (x^2 + 4)^2 = (x^2 + 4)(x^2 + 4) \\ & x^4 + 4x^2 + 4x^2 + 16 \\ & x^4 + 8x^2 + 16 \end{aligned}$$

27.

$$\begin{aligned} & (5x - 2y)^2 = (5x - 2y)(5x - 2y) \\ & 25x^2 - 10xy - 10xy - 4y^2 \\ & 25x^2 - 20xy - 4y^2 \end{aligned}$$

28.

$$(13x^2 + 2y)^2 = (13x^2 + 2y)(13x^2 + 2y)$$

$$169x^4 + 26x^2y + 26x^2y + 4y^2$$

$$169x^4 + 52x^2y + 4y^2$$

29.

$$4x(x + 6)(4x - 9) = 0$$

$$4x = 0$$

$$x = 0$$

$$x + 6 = 0$$

$$x = -6$$

$$4x - 9 = 0$$

$$4x = 9$$

$$x = \frac{9}{4} = 2\frac{1}{4}$$

$$x = 0, -6, 2\frac{1}{4}$$

30.

$$x(5x - 4) = 0$$

$$x = 0$$

$$5x - 4 = 0$$

$$5x = 4$$

$$x = \frac{4}{5}$$

$$x = 0, \frac{4}{5}$$

$$31. -12n + 28n + 4 = 4(-3n + 7n + 1)$$

$$32. 45x^{10} + 45x^7 + 18x^4 = 9x^4(5x^6 + 5x^3 + 2)$$

$$33. -16y^5 - 8y^5x^2 + 40y^6x^3 = -8y^5(2 + x^2 - 5yx^3)$$

$$34. 15u^4 - 10u^6 - 10u^3v = 5u^3(3u - 2u^3 - 2v)$$

$$35. -6a^9 + 20a^4b + 10a^3 = -2a^3(3a^6 - 10ab - 5)$$

$$36. 12x + 27y^2 - 27x^6 = 3(4x + 9y^2 - 9x^6)$$

$$37. (x^2 - 100) = (x + 10)(x - 10)$$

$$38. (x^2 - 1) = (x + 1)(x - 1)$$

$$39. (16x^2 - 25) = (4x + 5)(4x - 5)$$

$$40. (4x^2 - 81) = (2x + 9)(2x - 9)$$

$$41. (5n^2 + 25n) = 5n(n + 5)$$

42.

$$7r^2 + 37r + 36$$

$$7r^2 + 28r + 9r + 36$$

$$(7r^2 + 28r) + (9r + 36)$$

$$7r(r + 4) + 9(r + 4)$$

$$(7r + 9)(r + 4)$$

$$43. \begin{array}{l} 4v^2 + 36v \\ 4v(v + 9) \end{array}$$

44.

$$336xy - 288x^2 + 294y - 252x$$

$$6(56xy - 48x^2 + 49y - 42x)$$

$$6 \cdot (56xy - 48x^2) + (49y - 42x)$$

$$6 \cdot 8x(7y - 6x) + 7(7y - 6x)$$

$$6(8x + 7)(7y - 6x)$$

45.

$$10xy - 25x + 8y - 20$$

$$(10xy - 25x) + (8y - 20)$$

$$5x(2y - 5) + 4(2y - 5)$$

$$(5x + 4)(2y - 5)$$

46.

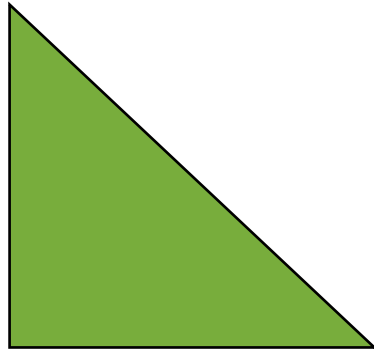

$$a^2 + b^2 = c^2$$

$$x^2 + (x + 3)^2 = 15^2$$

$$x^2 + x^2 + 3x + 3x + 9 - 225 = 0$$

$$2x^2 + 6x - 216 = 0$$

$$2(x^2 + 3x - 108) = 0$$

$$2(x + 12)(x - 9) = 0$$

$$2 \neq 0$$

$$x + 12 = 0$$

$$\cancel{x = -12}$$

$$x - 9 = 0$$

$$x = 9$$

$$x + 3 = 12$$

The three sides of the triangle are 9, 12, and 15 feet.

47.

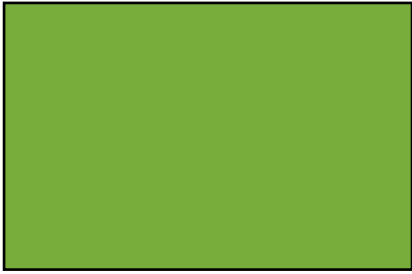

$$A = l \cdot w$$

$$A = (x + 5)(x - 3)$$

$$48 = (x + 5)(x - 3)$$

$$48 = x^2 - 3x + 5x - 15$$

$$x^2 + 2x - 15 - 48 = 0$$

$$x^2 + 2x - 63 = 0$$

$$(x + 9)(x - 7) = 0$$

$$x + 9 = 0$$

$$~~x = -9~~$$

$$x - 7 = 0$$

$$x = 7$$

48. The two events are mutually inclusive because the first event (choosing the sports section) and the second event (choosing the movie times list) can occur at the same time, and neither one affects the outcome of the other.

49.

$$P(A \cap B) = P(A) + P(B)$$

$$P(A) = P(\text{spin } 5) = \frac{1}{7}$$

$$P(B) = P(\text{roll } 5) = \frac{1}{6}$$

$$P(A \cap B) = \frac{1}{7} \cdot \frac{1}{6} = \frac{1}{42}$$

50. No, spinning a spinner and rolling a six-sided cube are mutually inclusive events, not mutually exclusive. Both can happen at the same time and neither one affects the outcome of the other.

51. Yes, spinning a spinner and rolling a six-sided cube are independent events. Neither one affects the outcome of the other.

52.

$$P(A \text{ or } B) = P(A) + P(B) - P(A \cap B)$$

$$P(A) = P(\text{spin } 3, 4, \text{ or } 5) = \frac{3}{7}$$

$$P(B) = P(\text{roll } 2) = \frac{1}{6}$$

$$P(A \cap B) = \frac{3}{7} \cdot \frac{1}{6} = \frac{1}{14}$$

$$P(A \text{ or } B) = \frac{3}{7} + \frac{1}{6} - \frac{1}{14} = \frac{18}{42} + \frac{7}{42} - \frac{3}{42} = \frac{25}{42} - \frac{7}{42} = \frac{18}{42} = \frac{3}{7}$$

Lesson 9.10

Chapter 9 Test

1.

$$\begin{aligned} & (4x^2 + 5x + 1) - (2x^2 - x - 3) \\ & 4x^2 + 5x + 1 - 2x^2 + x + 3 \\ & (4x^2 - 2x^2) + (5x + x) + (1 + 3) \\ & 2x^2 + 6x + 4 \end{aligned}$$

2.

$$\begin{aligned} & (2x + 5) - (x^2 + 3x - 4) \\ & 2x + 5 - x^2 - 3x + 4 \\ & -x^2 + (2x - 3x) + (5 + 4) \\ & -x^2 - x + 9 \end{aligned}$$

3.

$$\begin{aligned} & (b + 4c) + (6b + 2c + 3d) \\ & b + 4c + 6b + 2c + 3d \\ & 7b + 6c + 3d \end{aligned}$$

4.

$$\begin{aligned} & (5x^2 + 3x + 3) + (3x^2 - 6x + 4) \\ & 5x^2 + 3x + 3 + 3x^2 - 6x + 4 \\ & 8x^2 - 3x + 7 \end{aligned}$$

5.

$$(3x + 4)(x - 5)$$

$$3x^2 - 15x + 4x - 20$$

$$3x^2 - 11x - 20$$

6.

$$(9x^2 + 2)(x + 3)$$

$$9x^3 + 27x^2 + 2x + 6$$

7.

$$(4x + 3)(8x^2 + 2x + 7)$$

$$36x^3 + 8x^2 + 28x + 24x^2 + 6x + 21$$

$$36x^3 + 32x^2 + 34x + 21$$

8.

$$27x^2 - 18x + 3$$

$$3(9x^2 - 6x + 1)$$

$$3(9x^2 - 3x - 3x + 1)$$

$$3(9x^2 - 3x)(-3x + 1)$$

$$3 \cdot 3x(3x - 1) - (3x - 1)$$

$$3(3x - 1)(3x - 1)$$

$$3(3x - 1)^2$$

9.

$$9n^2 - 100$$

$$(3n - 10)(3n + 10)$$

10.

$$\begin{aligned} &648x^2 - 32 \\ &8(81x^2 - 4) \\ &8(9x - 2)(9x + 2) \end{aligned}$$

11.

$$\begin{aligned} &81p^2 - 90p + 25 \\ &81p^2 - 45p - 45p + 25 \\ &(81p^2 - 45p) + (-45p + 25) \\ &9p(9p - 5) - 5(9p - 5) \\ &(9p - 5)(9p - 5) \\ &(9p - 5)^2 \end{aligned}$$

12.

$$\begin{aligned} &6x^2 - 35x + 49 \\ &6x^2 - 14x - 21x + 49 \\ &(6x^2 - 14x) + (-21x + 49) \\ &2x(3x - 7) - 7(3x - 7) \\ &(2x - 7)(3x - 7) \end{aligned}$$

13.

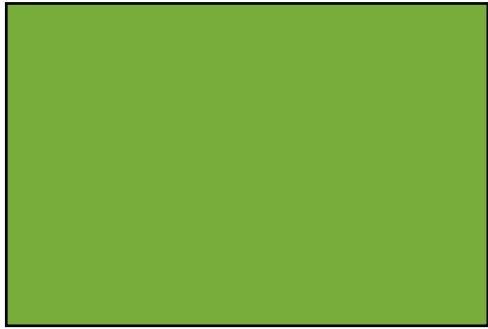

$$A = l \cdot w$$

$$45 = (x + 7)(x - 5)$$

$$45 = x^2 - 5x + 7x - 35$$

$$x^2 + 2x - 35 - 45 = 0$$

$$x^2 + 2x - 80 = 0$$

$$(x + 10)(x - 8) = 0$$

$$x + 10 = 0$$

$$~~x = -10~~$$

$$x - 8 = 0$$

$$x = 8$$

When $x=8$ then the area of the rectangle is 45.

14.

$$x(x + 6) = 40$$

$$x^2 + 6x - 40 = 0$$

$$(x + 10)(x - 4) = 0$$

$$x + 10 = 0$$

$$~~x = -10~~$$

$$x - 4 = 0$$

$$x = 4$$

15. Answers for this question will vary. The answer is correct as long as the two events do not affect each others outcome. (picking a card, and rolling a die, spinning a spinner and choosing a marble, etc.) The probability of each event will be the number of times you can achieve the desired outcome over the number of possible outcomes. (ie: die = 1/6)

(a) The answer will vary based on the events and probabilities chosen but should use the formula: $P(A \cup B) = P(A) + P(B) - P(A \cap B)$

(b) The answer will vary based on the events and probabilities chosen but should use the formula: $P(A \cap B) = P(A) \cdot P(B)$

16.

(a)

$$P(\text{rain}) = \frac{45}{100} = \frac{9}{20}$$

$$P(3\text{days}) = \frac{9}{20} \cdot \frac{9}{20} \cdot \frac{9}{20} = \frac{729}{8000}$$

(b)

$$P(\text{rain}) = \frac{45}{100} = \frac{9}{20}$$

$$P(\text{dry}) = \frac{55}{100} = \frac{11}{20}$$

$$P(\text{rain,dry,rain}) = \frac{9}{20} \cdot \frac{11}{20} \cdot \frac{9}{20} = \frac{891}{8000}$$

Basic Algebra Flexbook Solution Key
Chapter 10
Quadratic Equations and Functions

Lesson 10.1
Graphs of Quadratic Functions

1.
 - (1) The *vertex* is the point at which a parabola reaches its maximum or minimum (top or bottom).
 - (2) The *line of symmetry* is the imaginary line which runs through the vertex of a parabola dividing it into equal halves.
 - (3) A *parabola* is the shape created by the graph of a quadratic function. It is a U-shaped figure that can open either up or down.
 - (4) The minimum is the vertex of a parabola that opens upward (the lowest point).
 - (5) The maximum is the vertex of a parabola that opens downward (the highest point).
2. You can tell if $y = ax^2 + bx + c$ opens up or down by whether a is negative or positive.
3.
 - (1) vertex is (25, 610)
 - (2) y-intercept is (0,0)
 - (3) x-intercepts are (0,0) and (50,0)
 - (4) domain is all real numbers
 - (5) range is $y \leq 610$
 - (6) line of symmetry is $x = 25$
 - (7) a is negative
 - (8) $-1 < a < 1$

4.

(1)

$$d(s) = \frac{1}{20}s^2 + s$$

$$d(45) = \frac{1}{20}(45)^2 + 45$$

$$d(45) = \frac{1}{20}(2025) + 45$$

$$d(45) = \frac{405}{4} + 45$$

$$d(45) = 101.25 + 45$$

$$d(45) = 146.25$$

(2)

$$d(s) = \frac{1}{20}s^2 + s$$

$$96 = \frac{1}{20}s^2 + s$$

s	$\frac{1}{20}s^2 + s$	d
10	$1/20(10)^2 + 10 = 1/20(100) + 10 = 5 + 10 = 15$	15
20	$1/20(20)^2 + 20 = 1/20(400) + 20 = 20 + 20 = 40$	40
30	$1/20(30)^2 + 30 = 1/20(900) + 30 = 45 + 30 = 75$	75
40	$1/20(40)^2 + 40 = 1/20(1600) + 40 = 80 + 40 = 120$	120

s	$\frac{1}{20}s^2 + s$	d
32	$1/20(32)^2 + 32 = 1/20(1024) + 32 = 51.2 + 32 = 83.2$	83.2
34	$1/20(34)^2 + 34 = 1/20(1156) + 34 = 57.8 + 34 = 91.8$	91.8
36	$1/20(36)^2 + 36 = 1/20(1296) + 36 = 64.8 + 36 = 100.8$	100.8

$$1/20(35)^2 + 35 = 1/20(1225) + 35 = 61.25 + 35 = 96.25$$

$$d \approx 35$$

5.

$$D = 16t^2$$

$$D = 16(3.5)^2$$

$$D = 16(12.25)$$

$$D = 196$$

6. $y=2x^2$

x	$2x^2$	y
-3	$2(-3)^2 = 2(9)=18$	18
-2	$2(-2)^2 = 2(4)=8$	8
-1	$2(-1)^2 = 2(1)=2$	2
0	$2(0)^2 = 2(0)=0$	0
1	$2(1)^2 = 2(1)=2$	2
2	$2(2)^2 = 2(4)=8$	8
3	$2(3)^2 = 2(9)=18$	18

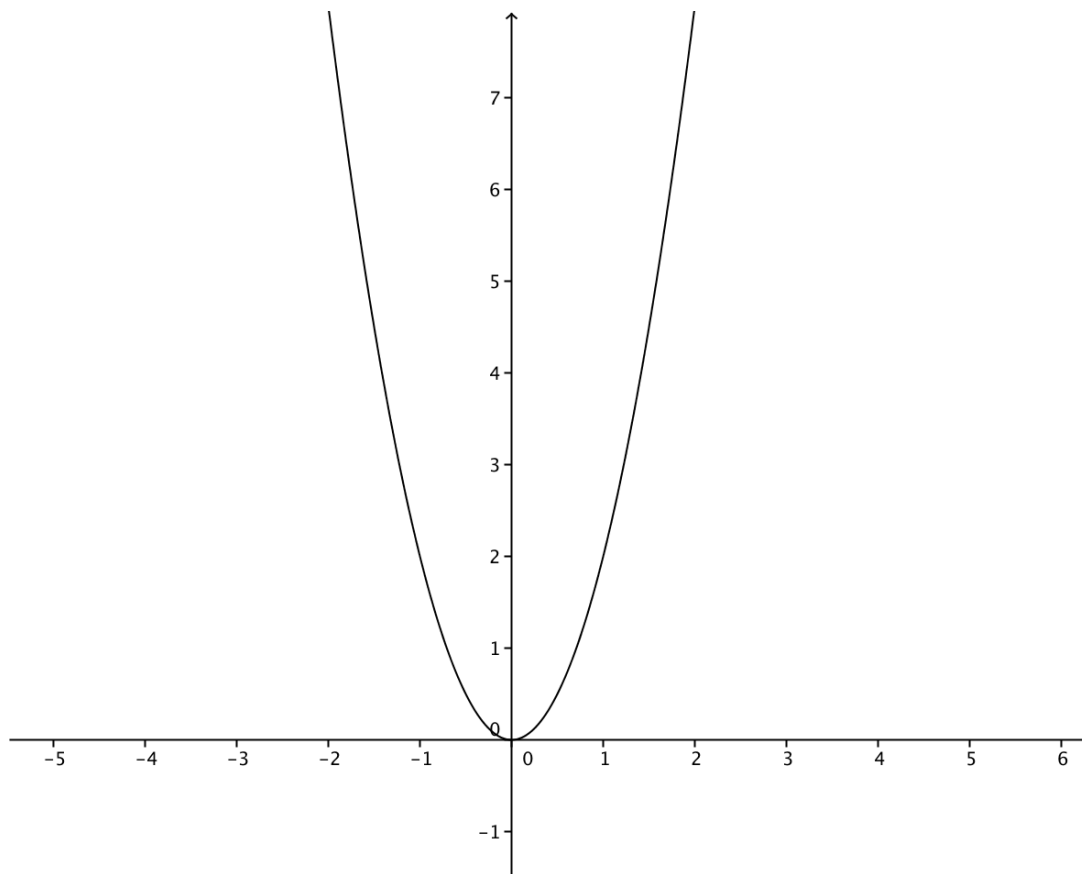

domain is $y \geq 0$

7. $y = -x^2$

x	$-x^2$	y
-3	$-(-3)^2 = -9$	-9
-2	$-(-2)^2 = -4$	-4
-1	$-(-1)^2 = -1$	-1
0	$-(0)^2 = 0$	0
1	$-(1)^2 = -1$	-1
2	$-(2)^2 = -4$	-4
3	$-(3)^2 = -9$	-9

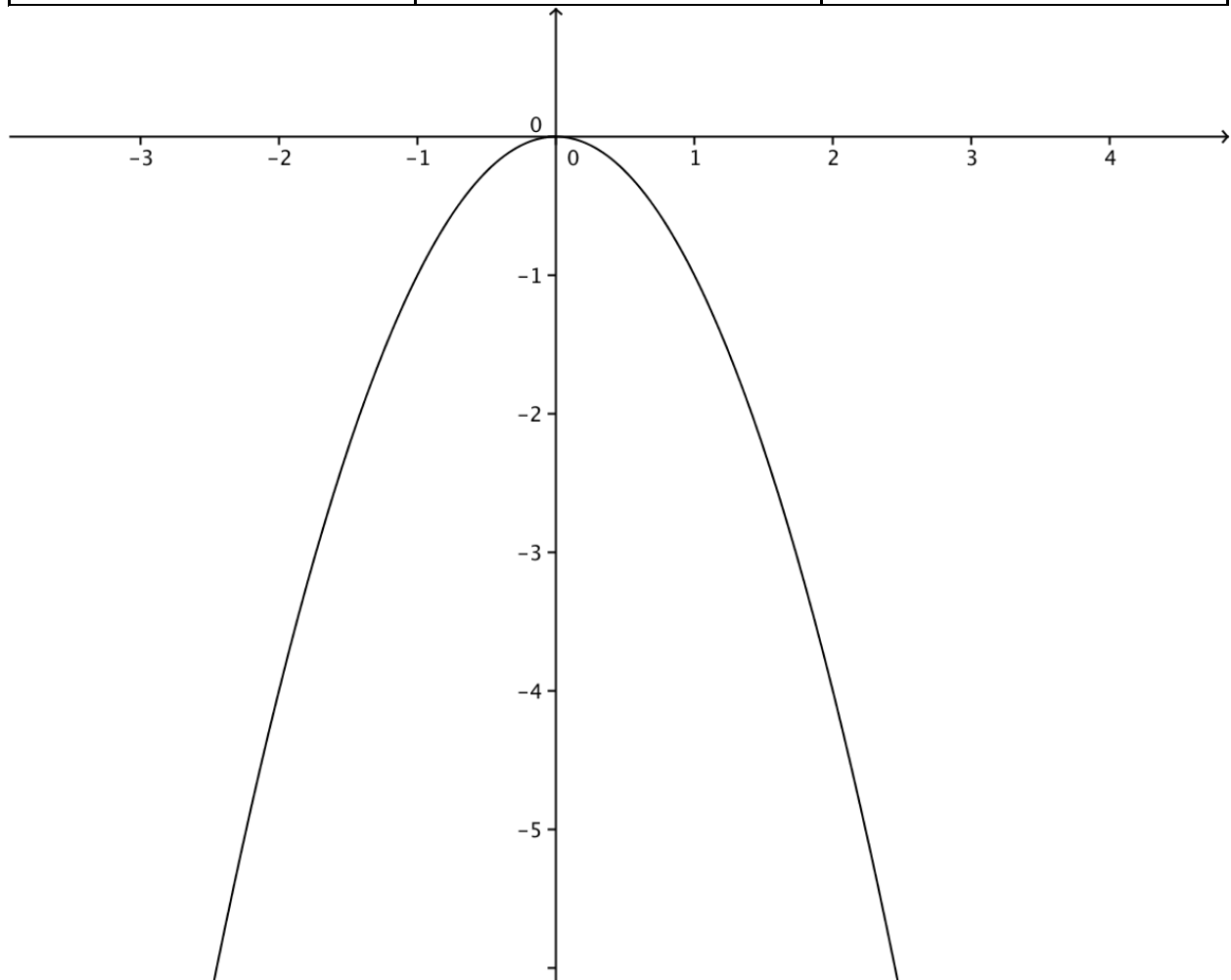

domain is $y \leq 0$

8. $y = x^2 - 2x + 3$

x	$x^2 - 2x + 3$	y
-3	$(-3)^2 - 2(-3) + 3 = 9 + 6 + 3 = 18$	18
-2	$(-2)^2 - 2(-2) + 3 = 4 + 4 + 3 = 11$	11
-1	$(-1)^2 - 2(-1) + 3 = 1 + 2 + 3 = 6$	6
0	$(0)^2 - 2(0) + 3 = 0 + 0 + 3 = 3$	3
1	$(1)^2 - 2(1) + 3 = 1 - 2 + 3 = 2$	2
2	$(2)^2 - 2(2) + 3 = 4 - 4 + 3 = 3$	3
3	$(3)^2 - 2(3) + 3 = 9 - 6 + 3 = 6$	6

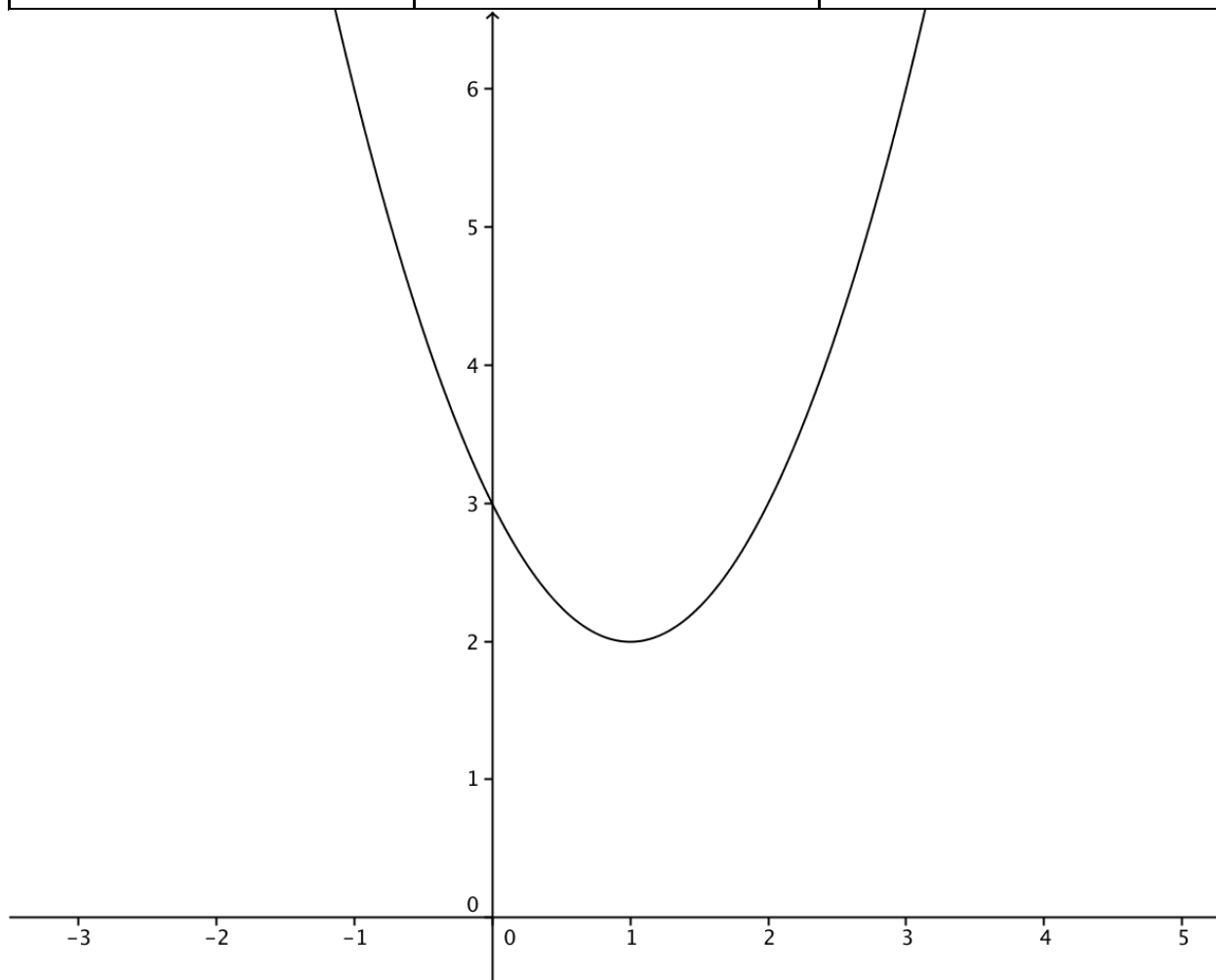

domain is $y \geq 2$

9. $y = 2x^2 + 4x + 1$

x	$2x^2+4x+1$	y
-3	$2(-3)^2 + 4(-3) + 1 = 2(9) - 12 + 1 = 18 - 12 + 1 = 7$	7
-2	$2(-2)^2 + 4(-2) + 1 = 2(4) - 8 + 1 = 8 - 8 + 1 = 1$	1
-1	$2(-1)^2 + 4(-1) + 1 = 2(1) - 4 + 1 = 2 - 4 + 1 = -1$	-1
0	$2(0)^2 + 4(0) + 1 = 2(0) + 0 + 1 = 0 + 0 + 1 = 1$	1
1	$2(1)^2 + 4(1) + 1 = 2(1) + 4 + 1 = 2 + 4 + 1 = 7$	7
2	$2(2)^2 + 4(2) + 1 = 2(4) + 8 + 1 = 8 + 8 + 1 = 17$	17
3	$2(3)^2 + 4(3) + 1 = 2(9) + 12 + 1 = 18 + 12 + 1 = 21$	21

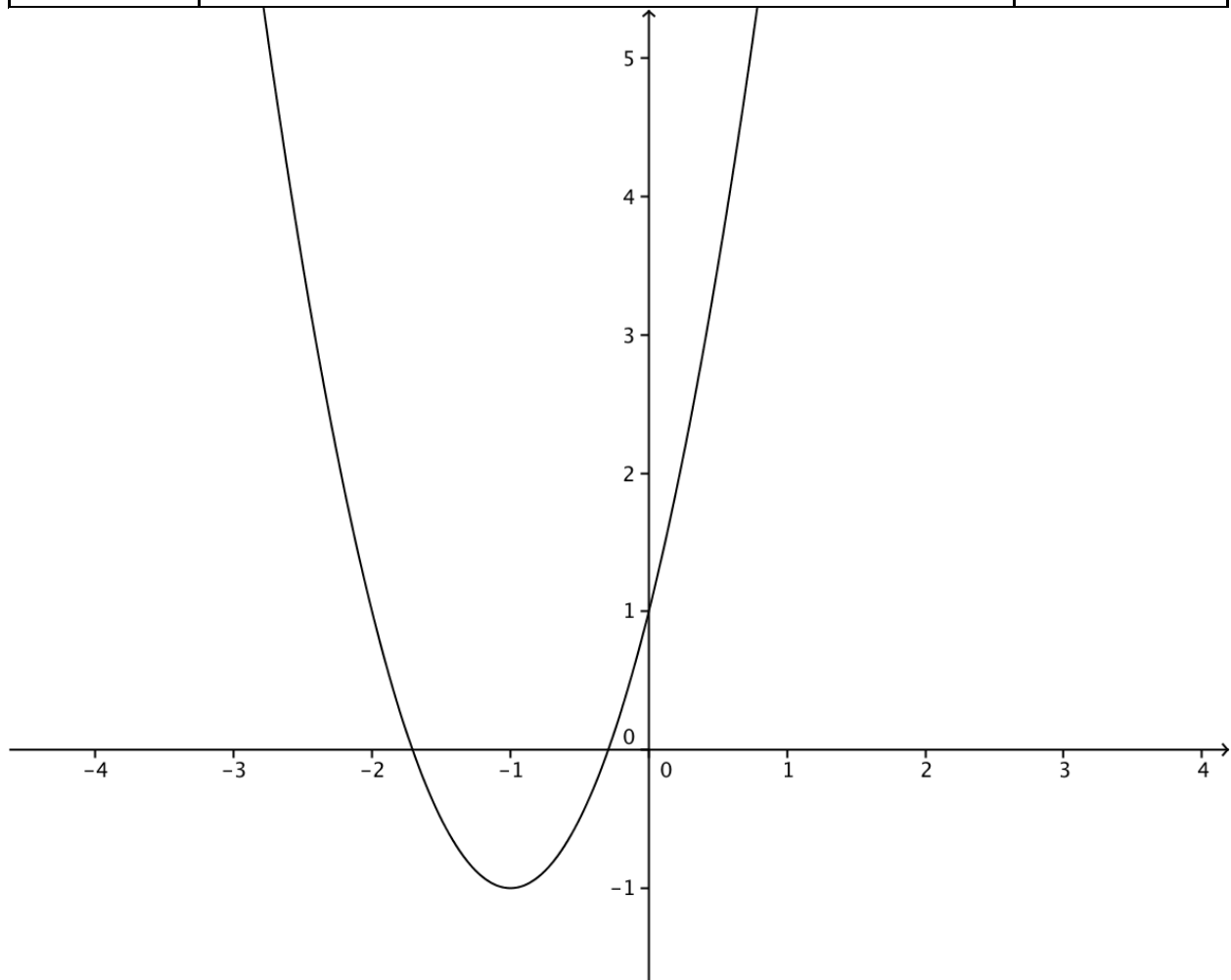

domain is $y \geq -1$

10. $y = -x^2 + 3$

x	$-x^2+3$	y
-3	$-(-3)^2+3= -9+3= -6$	-6
-2	$-(-2)^2+3= -4+3= -1$	-1
-1	$-(-1)^2+3= -1+3= 2$	2
0	$-(0)^2+3= 0+3= 3$	3
1	$-(1)^2+3= -1+3= 2$	2
2	$-(2)^2+3= -4+3= -1$	-1
3	$-(3)^2+3= -9+3= -6$	-6

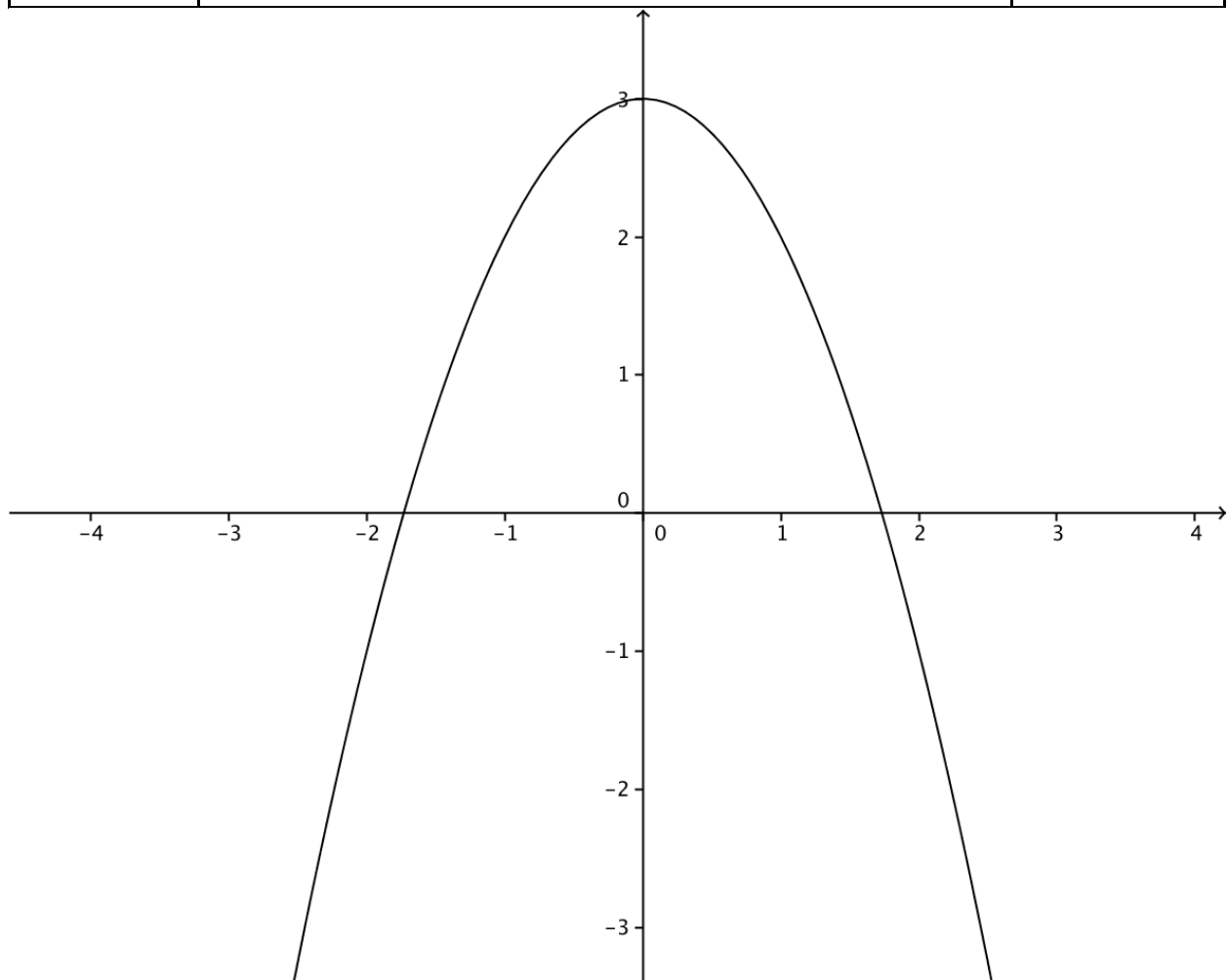

domain is $y \leq 3$

11. $y = x^2 - 8x + 3$

x	$x^2 - 8x + 3$	y
-3	$(-3)^2 - 8(-3) + 3 = 9 + 24 + 3 = 36$	36
-2	$(-2)^2 - 8(-2) + 3 = 4 + 16 + 3 = 23$	23
-1	$(-1)^2 - 8(-1) + 3 = 1 + 8 + 3 = 12$	12
0	$(0)^2 - 8(0) + 3 = 0 - 0 + 3 = 3$	3
1	$(1)^2 - 8(1) + 3 = 1 - 8 + 3 = -4$	-4
2	$(2)^2 - 8(2) + 3 = 4 - 16 + 3 = -9$	-9
3	$(3)^2 - 8(3) + 3 = 9 - 24 + 3 = -12$	-12

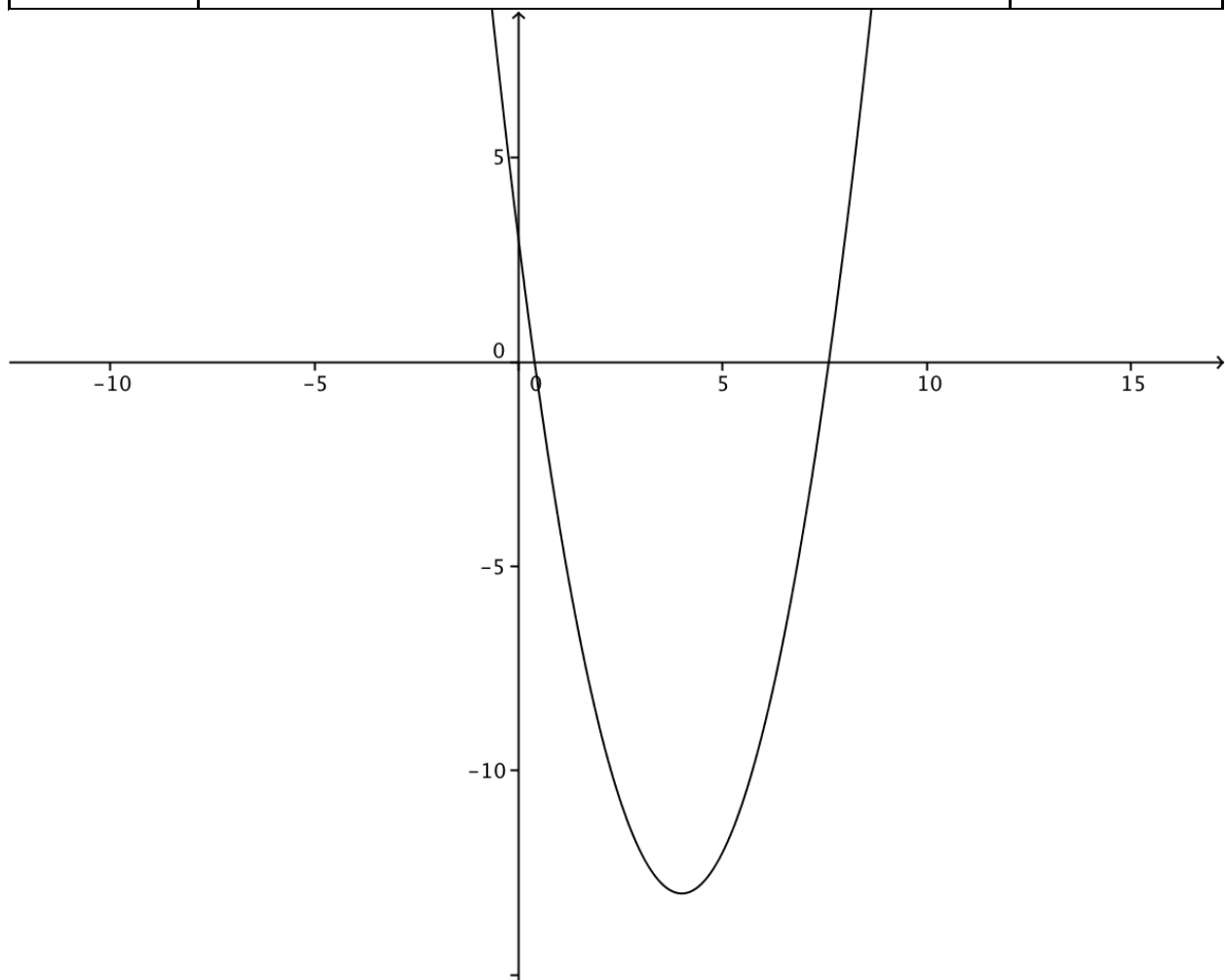

domain is $y \geq -13$

12. $y = x^2 - 4$

x	$x^2 - 4$	y
-3	$(-3)^2 - 4 = 9 - 4 = 5$	5
-2	$(-2)^2 - 4 = 4 - 4 = 0$	0
-1	$(-1)^2 - 4 = 1 - 4 = -3$	-3
0	$(0)^2 - 4 = 0 - 4 = -4$	-4
1	$(1)^2 - 4 = 1 - 4 = -3$	-3
2	$(2)^2 - 4 = 4 - 4 = 0$	0
3	$(3)^2 - 4 = 9 - 4 = 5$	5

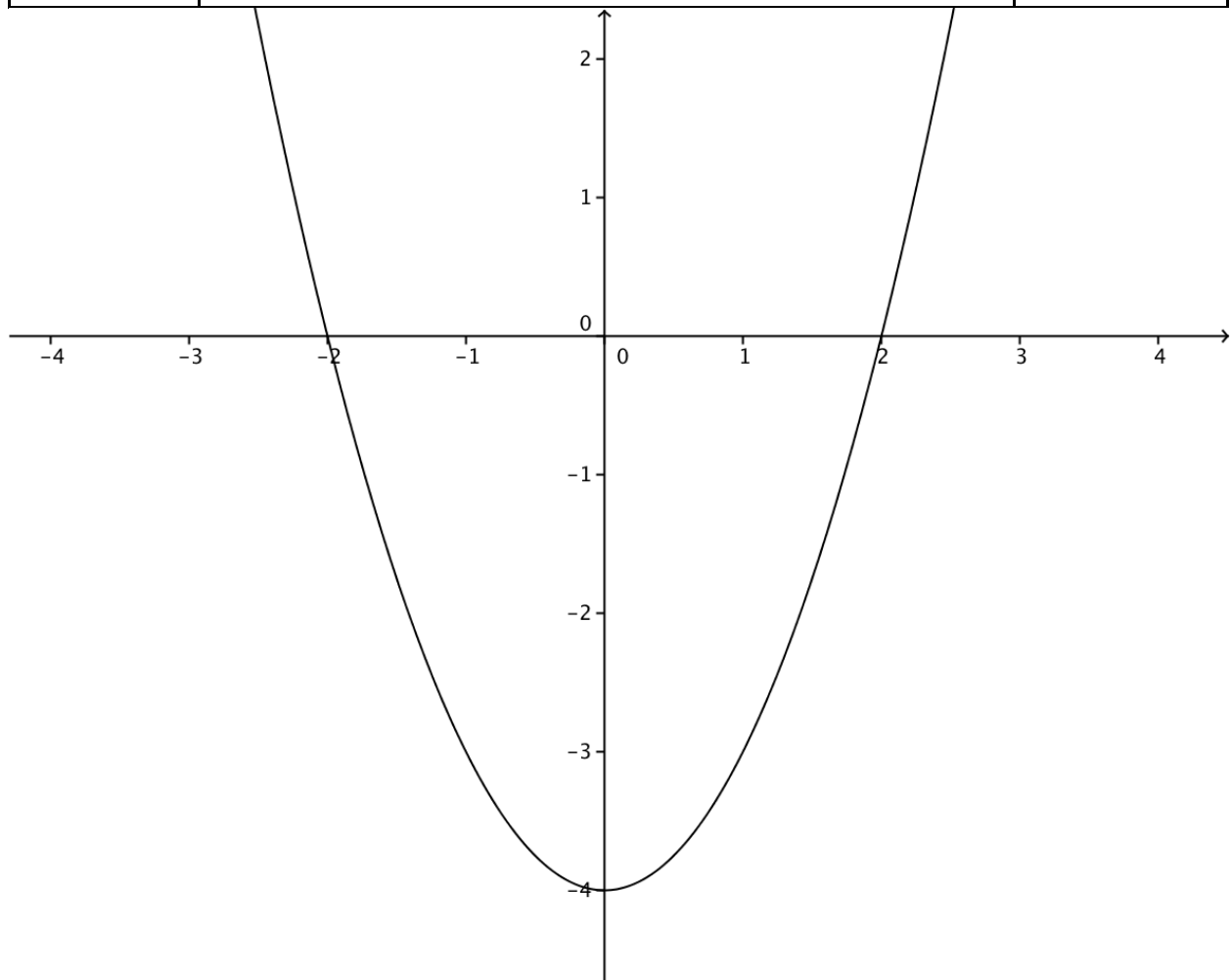

domain is $y \geq -4$

13. the y-intercepts are the same (0,0)
14. the y-intercepts are the same (4,0)
15. the y-intercepts are the same (-2,0)
16. a is positive so the parabola opens upward
 $-1 < a < 1$ so the parabola is wide about its line of symmetry
y-intercept = -8
17. a is negative so the parabola opens downward
 $a < -1$ so the parabola is narrow about its line of symmetry
y-intercept = -21
18. a is positive so the parabola opens upward
 $a > 1$ so the parabola is narrow about its line of symmetry
y-intercept = 4
19. the parabola opens down
20. the parabola opens up
21. the parabola opens down
22. $y=4x^2$ is more narrow around its line of symmetry because $a > 1$
23. both equations are equally narrow around their line of symmetry because $a = -2$ in both equations
24. both equations are equally narrow around their line of symmetry because $a = 3$ in both equations

25.

$$y = 4x^2 - 4$$

$$y = (2x - 2)(2x + 2)$$

$$2x - 2 = 0$$

$$2x = 2$$

$$x = 1$$

$$2x + 2 = 0$$

$$2x = -2$$

$$x = -1$$

x	$4x^2 - 4$	y
$3/2$	$4(3/2)^2 - 4 = 4(9/4) - 4 = 9 - 4 = 5$	5
1		0
$1/2$	$4(1/2)^2 - 4 = 4(1/4) - 4 = 1 - 4 = -3$	-3
0		-4
$-1/2$	$4(-1/2)^2 - 4 = 4(1/4) - 4 = 1 - 4 = -3$	-3
-1		0
$-3/2$	$4(-3/2)^2 - 4 = 4(9/4) - 4 = 9 - 4 = 5$	5

The x intercepts are 1 and -1, the y-intercept is -4.

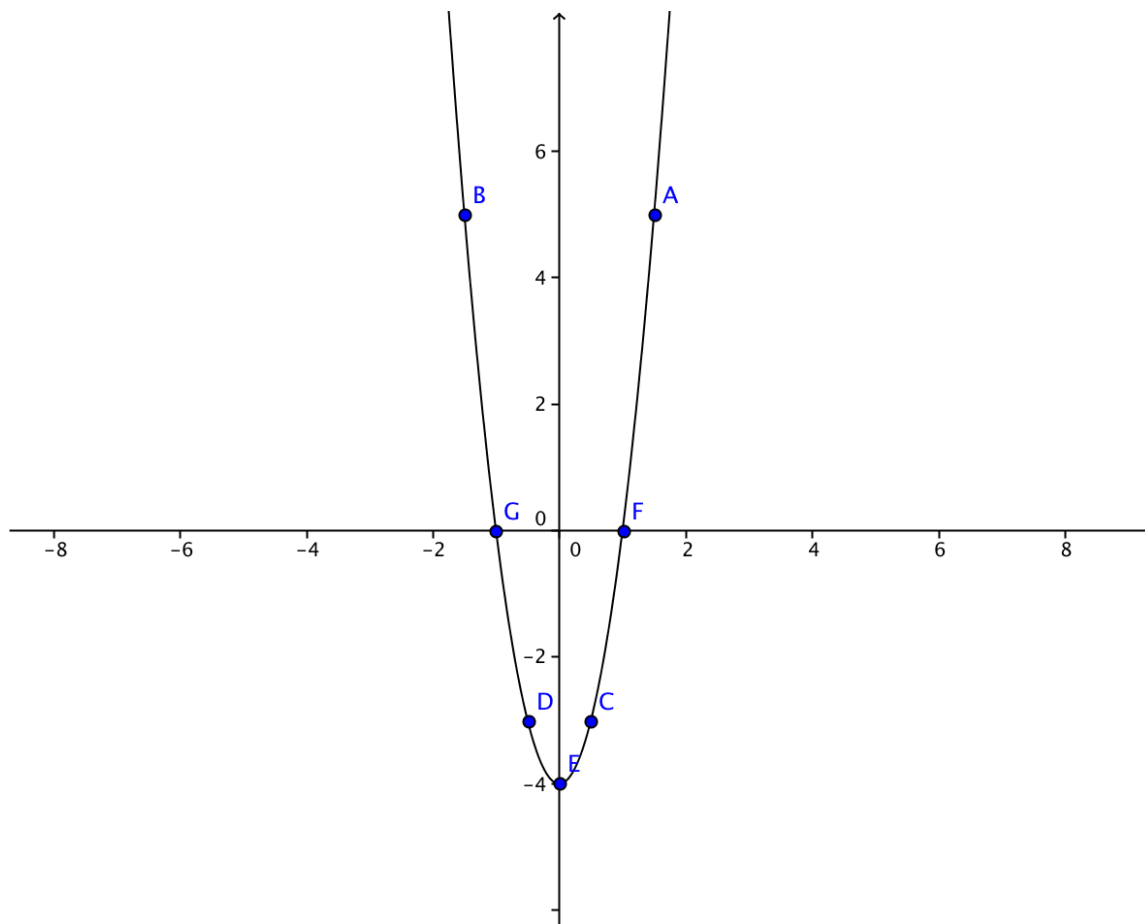

$$y = -x^2 + x + 12$$

$$y = -(x^2 - x - 12)$$

$$y = -(x - 4)(x + 3)$$

$$-(x - 4) = 0$$

$$-x + 4 = 0$$

$$-x = -4$$

$$x = 4$$

$$-(x + 3) = 0$$

$$-x - 3 = 0$$

$$-x = 3$$

$$x = -3$$

x	$-x^2+x+12$	y
4		0
3	$-(3)^2+3+12=-9+3+12=6$	6
2	$-(2)^2+2+12=-4+2+12=10$	10
1	$-(1)^2+1+12=-1+1+12=12$	12
0		12
-1	$-(-1)^2-1+12=-1-1+12=10$	10
-2	$-(-2)^2-2+12=-4-2+12=6$	6
-3		0
-4	$-(-4)^2-4+12=-16-4+12=-8$	-8

The x-intercepts are -3 and 4, and the y-intercept is 12.

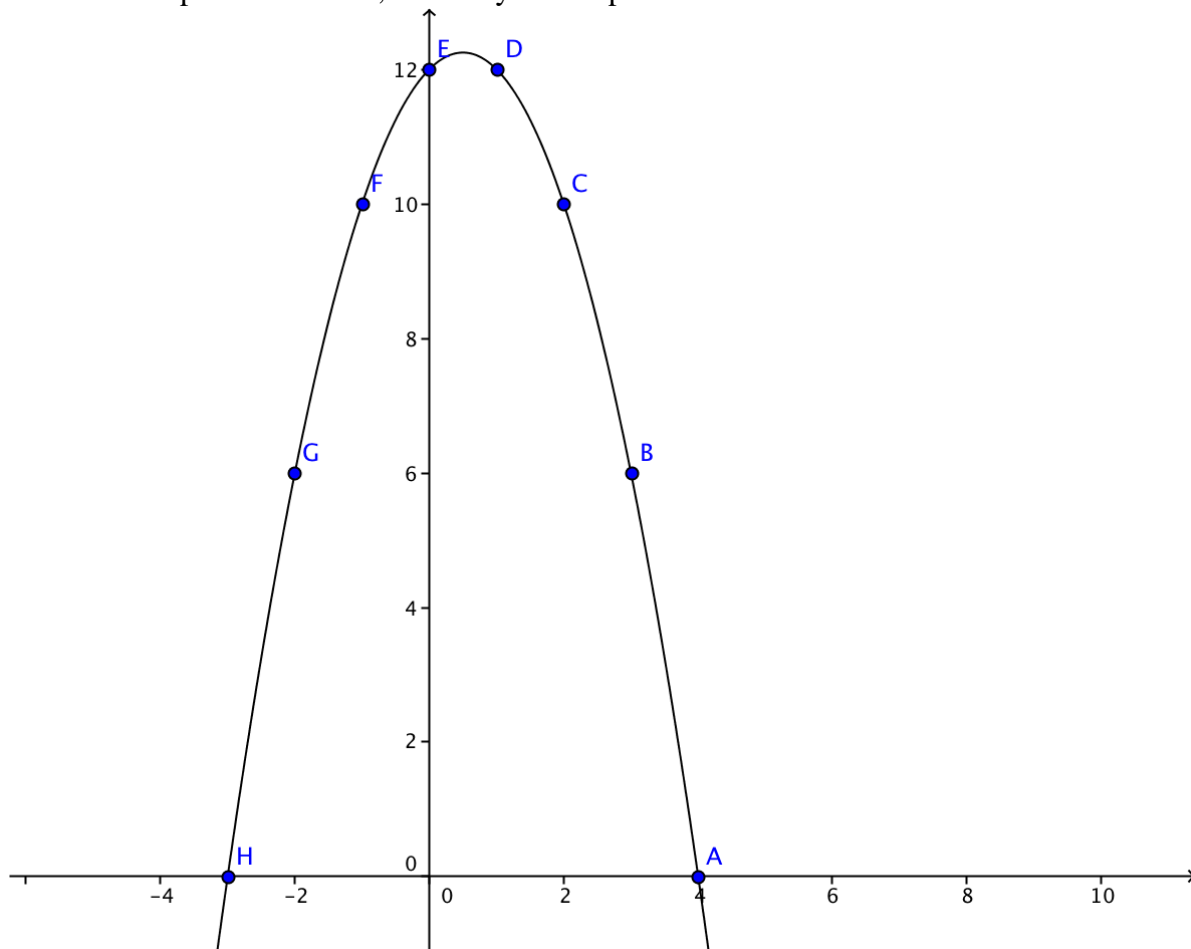

$$y = 2x^2 + 10x + 8$$

$$y = 2(x^2 + 5x + 4)$$

$$y = 2(x + 4)(x + 1)$$

$$2(x + 4) = 0$$

$$2x + 8 = 0$$

$$2x = -8$$

$$x = -4$$

$$2(x + 1) = 0$$

$$2x + 2 = 0$$

$$2x = -2$$

$$x = -1$$

x	$2x^2+10x+8$	y
0		8
-1		0
-2	$2(-2)^2+10(-2)+8=8-20+8=-4$	-4
-3	$2(-3)^2+10(-3)+8=18-30+8=-4$	-4
-4		0
-5	$2(-5)^2+10(-5)+8=50-50+8=8$	8

The x-intercepts are -4 and -1, and the y-intercept is 8.

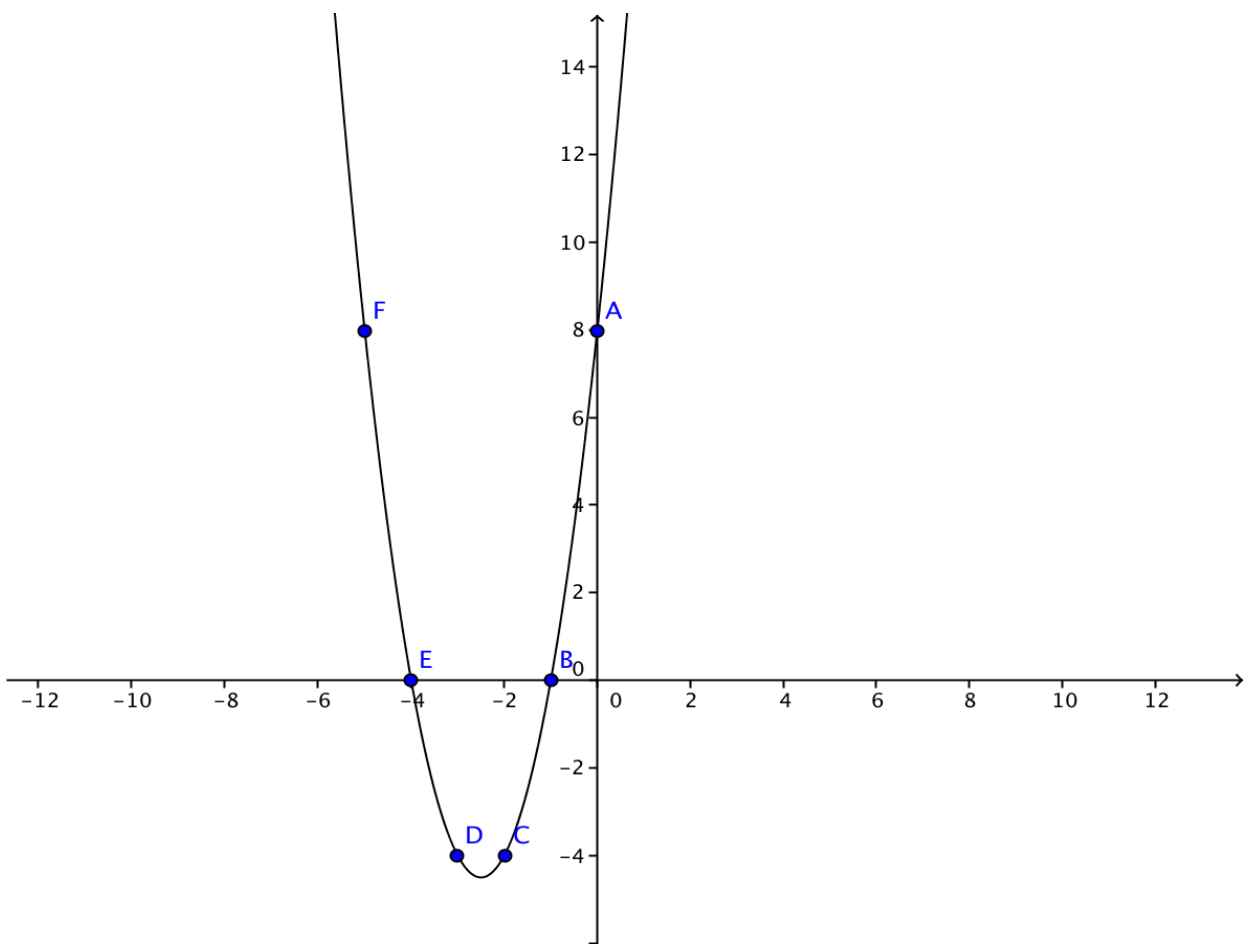

$$y = \frac{1}{2}x^2 - 2x$$

$$y = x\left(\frac{1}{2}x - 2\right)$$

$$x = 0$$

$$\frac{1}{2}x - 2 = 0$$

$$\frac{1}{2}x = 2$$

$$x = 4$$

The x-intercepts are 0 and 4, and the y-intercept is 0.

x	$\frac{1}{2}x^2 - 2x$	y
5	$\frac{1}{2}(5)^2 - 2(5) = 12.5 - 10 = 2.5$	$\frac{5}{2}$
4		0
3	$\frac{1}{2}(3)^2 - 2(3) = 4.5 - 6 = -1.5$	$-\frac{3}{2}$
2	$\frac{1}{2}(2)^2 - 2(2) = 2 - 4 = -2$	-2
1	$\frac{1}{2}(1)^2 - 2(1) = 0.5 - 2 = -1.5$	$-\frac{3}{2}$
0		0
-1	$\frac{1}{2}(-1)^2 - 2(-1) = 0.5 + 2 = 2.5$	$\frac{5}{2}$

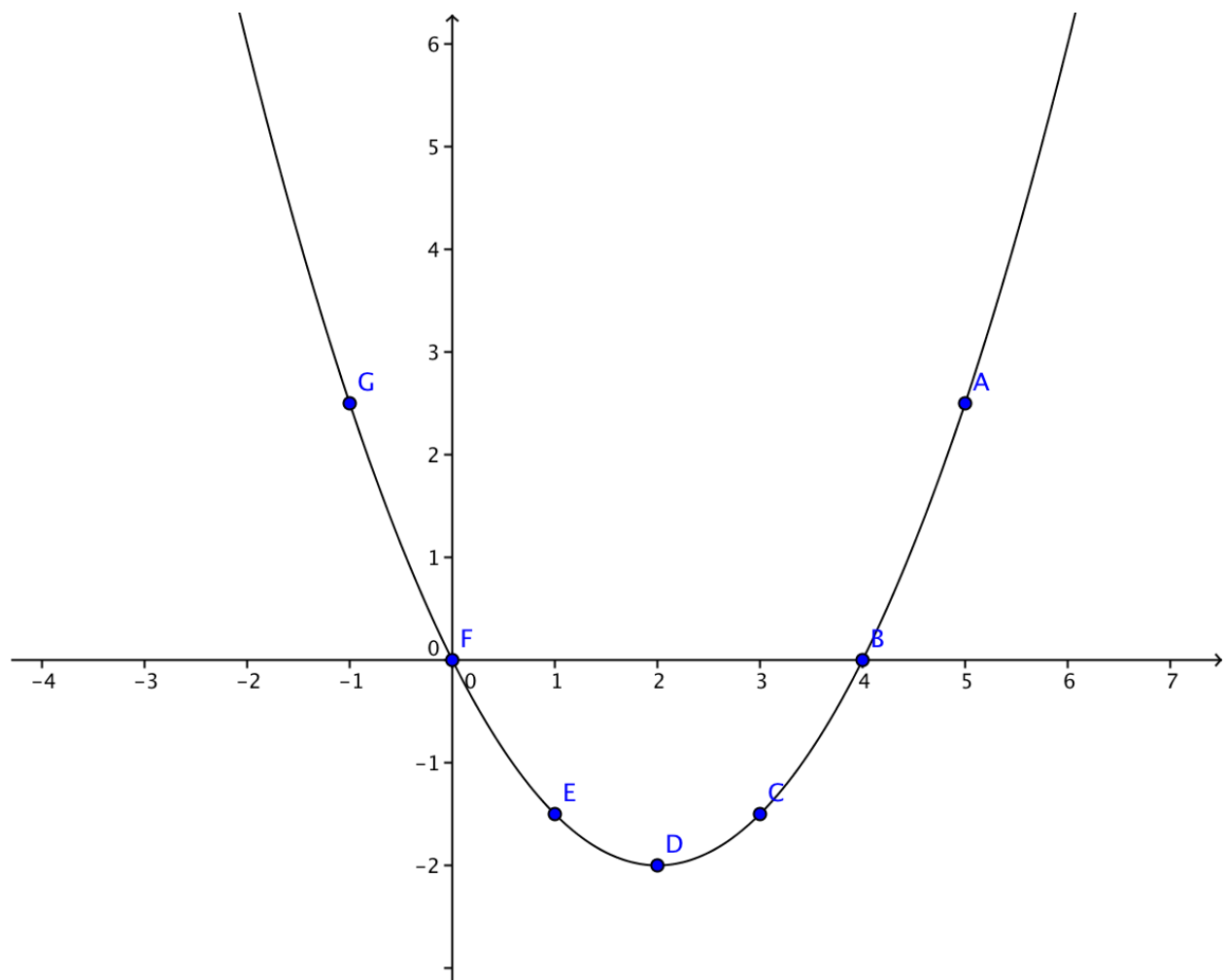

29.

$$y = x - 2x^2$$

$$y = -2x^2 + x$$

$$y = x(-2x + 1)$$

$$x = 0$$

$$-2x + 1 = 0$$

$$-2x = -1$$

$$-x = -\frac{1}{2}$$

$$x = \frac{1}{2}$$

x	$x-2x^2$	y
1	$(1)-2(1)^2=1-2=-1$	-1
1/2		0
0		0
-1/2	$(-1/2)-2(-1/2)^2=-1/2-1/2=-1$	-1
-1	$(-1)-2(-1)^2=-1-2=-3$	-3

The x-intercepts are 0 and 1/2, and the y-intercept is 0.

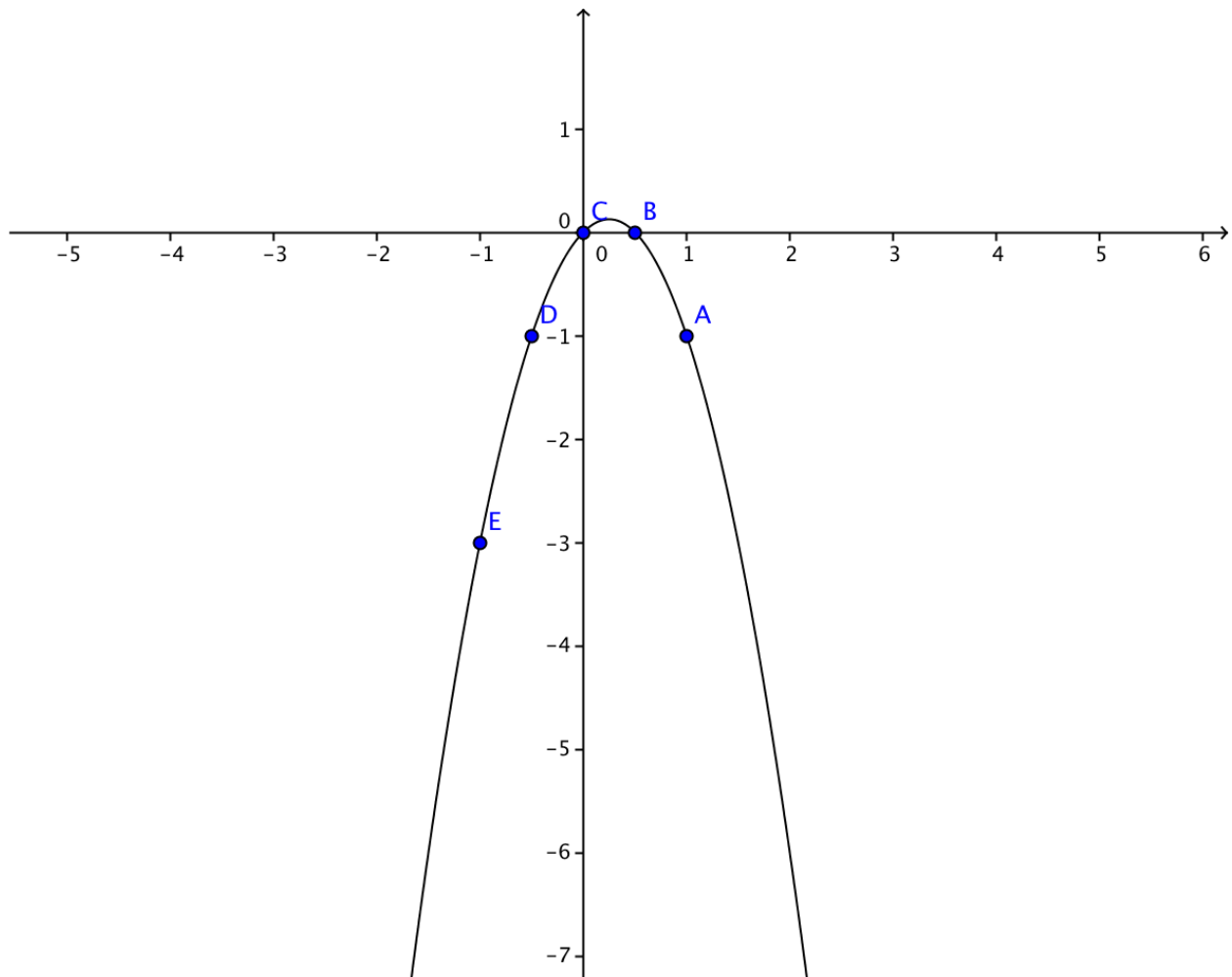

30.

$$y = 4x^2 - 8x + 4$$

$$y = 4(x^2 - 2x + 1)$$

$$y = 4(x - 1)^2$$

$$4(x - 1) = 0$$

$$4x - 4 = 0$$

$$4x = 4$$

$$x = 1$$

x	$4x^2 - 8x + 4$	y
0		4
1/2	$4(1/2)^2 - 8(1/2) + 4 = 1 - 4 + 4 = 1$	1
1		0
3/2	$4(3/2)^2 - 8(3/2) + 4 = 9 - 12 + 4 = 1$	1
2	$4(2)^2 - 8(2) + 4 = 16 - 16 + 4 = 4$	4

The x-intercept is 1 and the y-intercept is 4.

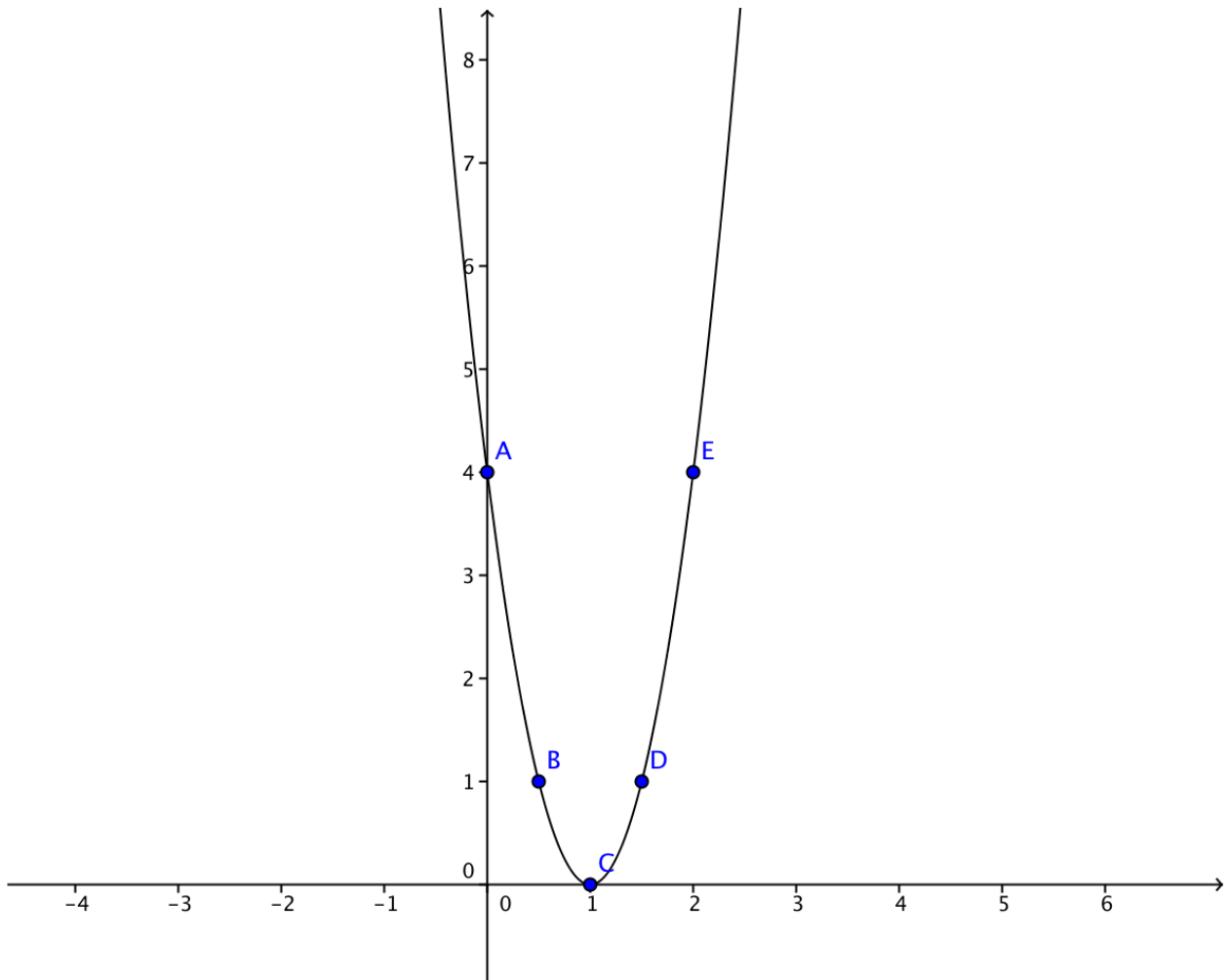

31. The ball hits the ground 14 feet away from Nadia. The distance from Nadia at which the ball reaches its maximum height is just over 6 feet away ($x \approx 6$). The maximum height is just over 10 feet ($y \approx 10$).

32. The parabola reaches its maximum height when $x=30$.

If the width equals 30 then the length is 60 ($l=120-2x=120-2(30)=60$).

The dimensions would be 30 feet by 60 feet giving a total area of 1800 square feet.

33.

$$6u^2v - 11u^2v^2 - 10u^2v^3$$

$$u^2v(6 - 11v - 10v^2)$$

34.

$$3x^2 + 11x + 10$$

$$(3 \cdot x \cdot x) + (11 \cdot x) + (5 \cdot 2)$$

35.

$$-\frac{1}{9}(63)\left(-\frac{3}{7}\right) = -7\left(-\frac{3}{7}\right) = 3$$

36.

$$|b+2|=9$$

$$(b+2)=9$$

$$b=7$$

$$-(b+2)=9$$

$$-b-2=9$$

$$-b=11$$

$$b=-11$$



$$b = 7, -11$$

37.

$$(4x^3y^2z)^3 = 4^3 \cdot x^{3 \cdot 3} \cdot y^{2 \cdot 3} \cdot z^{1 \cdot 3} = 64x^9y^6z^3$$

38.

$$7x + 4y = 9$$

$$4y = -7x + 9$$

$$y = -\frac{7}{4}x + \frac{9}{4}$$

$$y = -1.75x + 2.25$$

The slope is -1.75 and the y-intercept is 2.25.

Lesson 10.2

Solving Quadratic Equations by Graphing

1. Alternate names for the solution to a parabola are roots, zeros, or x-intercepts.

2.

1. h_0 is the initial height of the object.
2. t is the time (usually in seconds)
3. v_0 is the initial velocity
4. g is gravity due to acceleration (9.8 m/s or 32 ft/s)
5. $h(t)$ is equation that explains the height as a function of time of a projectile

3.

$$h(t) = -\frac{1}{2}(g)t^2 + v_0t + h_0$$

$$h(t) = -\frac{1}{2}(9.8)t^2 + 15t + 3$$

1. $h(t) = -4.9t^2 + 15t + 3$

Graph this polynomial to answer the following.

2. The maximum height is 14.48 meters. This height occurs at 1.53 seconds.
3. At four seconds the height is -16. This means that the rocket has already hit the ground and has stopped moving.
4. The rocket will hit the ground at 3.25 seconds.
5. The rocket will be 13 meters from the ground at 0.98 seconds and 2 seconds.

4. Two solutions

5. One solution

All solutions below are found by graphing the polynomial provided.

6. Two solutions

7. Two solutions

8. No solutions

9. The zero is 2.

10. The zeros are 1.67 and 0.

11. No solutions

12. The zeros are -1.19 and 1.69.

13. The zeros are 3 and -3.

14. The zero is -3.
15. The zero is 0.
16. No solutions
17. The zeros are 0.33 and 1.
18. The zeros are -1.5 and 1.5
19. The zeros are -0.27 and 7.27
20. The zero is -5.
21. The zeros are 0 and 1.5
22. No solutions
23. It takes 9.8 seconds to reach the ground.
24.
 - (a) The roots are -0.43 and -11.57
 - (b) The vertex is (-6,-31)
25.
 - (a) There are no roots to this equation.
 - (b) The vertex is (-1.5, 3.75)
26.
 - (a) The roots are -4.85 and 1.85
 - (b) The vertex is (-1.5, 11.25)

27.

$$\begin{cases} A = l(w) \\ 40 = 2l + 2w \end{cases}$$

$$40 = 2l + 2w$$

$$40 - 2l = 2w$$

$$\frac{40 - 2l}{2} = w$$

$$20 - l = w$$

$$A = l(w)$$

$$A = l(20 - l)$$

$$A = 20l - l^2$$

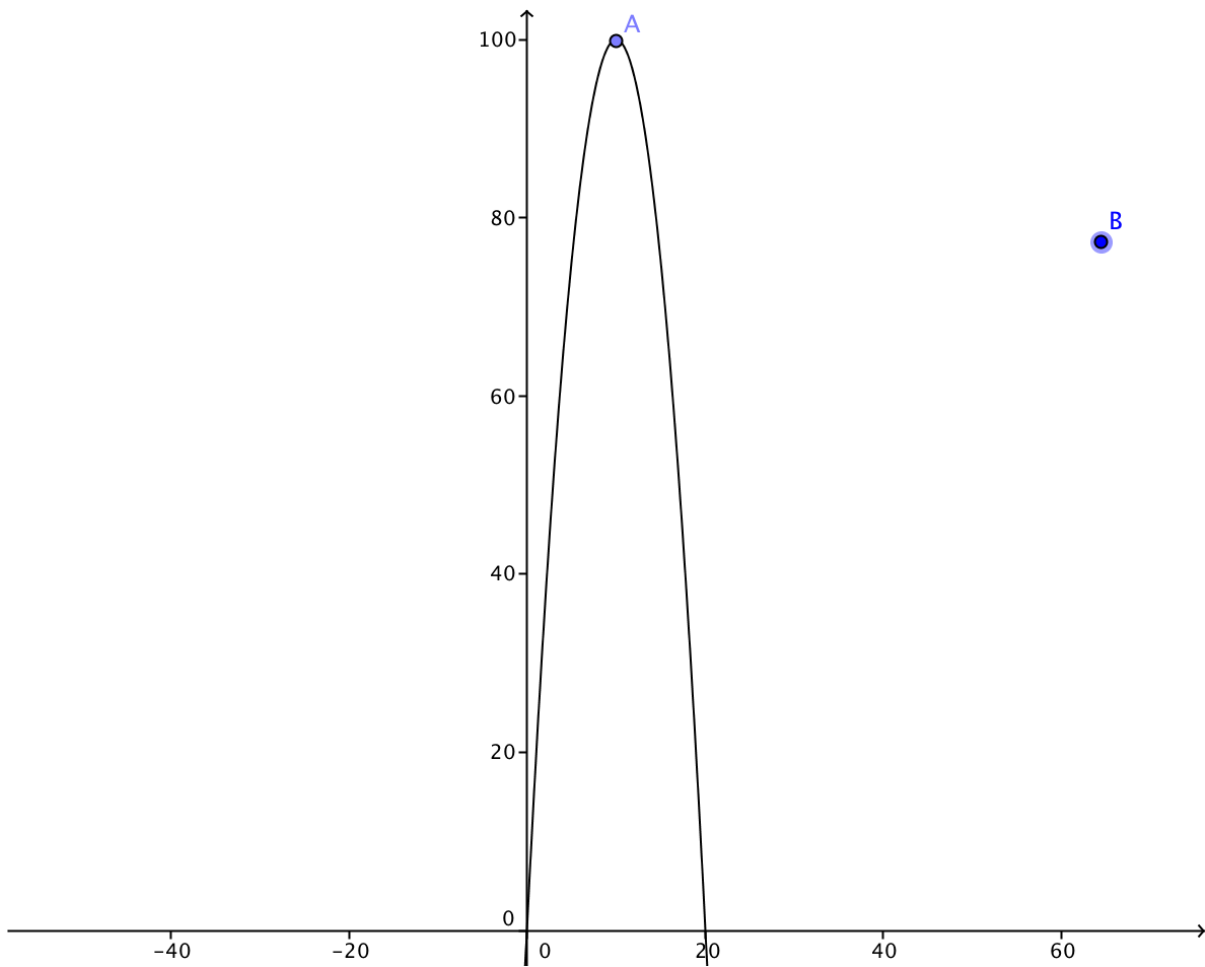

Based on the graph the largest area is 100 ft, which is created by making a 10ft by 10 ft square.

28.

$$h(t) = -\frac{1}{2}(g)t^2 + v_0t + h_0$$

1. $h(t) = -\frac{1}{2}(32)t^2 + (45)t + 5.2$

$$h(t) = -\frac{1}{2}(g)t^2 + v_0t + h_0$$

$$h(1) = -\frac{1}{2}(32)1^2 + (45)1 + 5.2$$

$$h(1) = -(16)1 + 45 + 5.2$$

$$h(1) = -16 + 50.2$$

2. $h(1) = 34.2$

The height of the ball after 1 second will be 34.2 ft.

3.

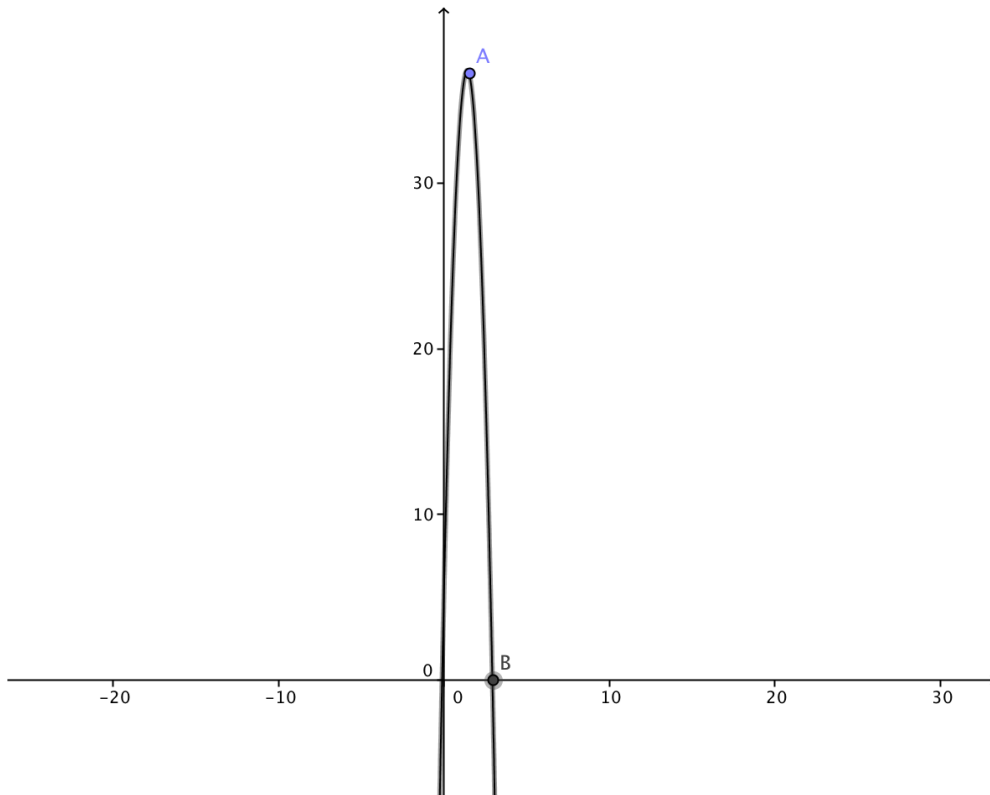

The maximum height of the ball is 36.69 feet.

4. The ball will hit the ground at 2.92 seconds

Mixed Review

$$3r^2 - 4r + 1$$

29. $(3r-1)(r-1)$

30.

$$(2 + \sqrt{3})(4 + \sqrt{3})$$

$$8 + 2\sqrt{3} + 4\sqrt{3} + 3$$

$$11 + 6\sqrt{3}$$

31.

$$9 - 3x + 18y = 0$$

$$-3x + 18y = -9$$

$$18y = 3x - 9$$

$$y = \frac{3}{18}x - \frac{9}{18}$$

$$y = \frac{1}{6}x - \frac{1}{2}$$

The slope is $1/6$ and the y-intercept is $-1/2$.

32.

$$y = a(1-r)^x$$

$$a = 100\% = 1$$

$$r = \frac{1}{2} = 0.5$$

$$x = 44 \div 16 = 2.75$$

$$y = 1(1 - 0.5)^{2.75}$$

$$y = (0.5)^{2.75}$$

$$y = 0.14865$$

The percentage remaining is 14.865%.

33.

$$0.00000009865 \times 123564.21$$

$$0.012189609317$$

$$1.2189609317 \times 10^{-2}$$

34.

A= 12% chlorine mixture

B= 30% chlorine mixture

15% of 150mL = 22.5 mL

$$\begin{cases} A + B = 150 \\ .12A + .30B = 22.5 \end{cases}$$

$$A + B = 150$$

$$B = 150 - A$$

$$.12A + .30B = 22.5$$

$$.12A + .30(150 - A) = 22.5$$

$$.12A + 45 - .30A = 22.5$$

$$-0.18A + 45 = 22.5$$

$$-0.18A = -22.5$$

$$A = 125$$

$$150 - 125 = 25$$

There should be 125mL of the 12% solution and 25mL of the 30% solution in order to create 150mL with 15% chlorine.

Lesson 10.3
Solving Quadratic Equations Using Square Roots

1.

$$x^2 = 196$$

$$\sqrt{x^2} = \sqrt{196}$$

$$x = \pm 14$$

2.

$$x^2 - 1 = 0$$

$$x^2 = 1$$

$$\sqrt{x^2} = \sqrt{1}$$

$$x = \pm 1$$

3.

$$x^2 - 100 = 0$$

$$x^2 = 100$$

$$\sqrt{x^2} = \sqrt{100}$$

$$x = \pm 10$$

4.

$$x^2 - 16 = 0$$

$$x^2 = 16$$

$$\sqrt{x^2} = \sqrt{16}$$

$$x = \pm 4$$

5.

$$9x^2 - 1 = 0$$

$$9x^2 = 1$$

$$x^2 = \frac{1}{9}$$

$$\sqrt{x^2} = \sqrt{\frac{1}{9}}$$

$$x = \pm \frac{1}{3}$$

6.

$$4x^2 - 49 = 0$$

$$4x^2 = 49$$

$$x^2 = 12.25$$

$$\sqrt{x^2} = \sqrt{12.25}$$

$$x = \pm 3.5$$

7.

$$64x^2 - 9 = 0$$

$$64x^2 = 9$$

$$x^2 = 0.140625$$

$$\sqrt{x^2} = \sqrt{0.140625}$$

$$x = \pm 0.375$$

8.

$$x^2 - 81 = 0$$

$$x^2 = 81$$

$$\sqrt{x^2} = \sqrt{81}$$

$$x = \pm 9$$

9.

$$25x^2 - 36 = 0$$

$$25x^2 = 36$$

$$x^2 = 1.44$$

$$\sqrt{x^2} = \sqrt{1.44}$$

$$x = \pm 1.2$$

10.

$$x^2 - 9 = 0$$

$$x^2 = 9$$

$$\sqrt{x^2} = \sqrt{9}$$

$$x = \pm 3$$

11.

$$x^2 - 16 = 0$$

$$x^2 = 16$$

$$\sqrt{x^2} = \sqrt{16}$$

$$x = \pm 4$$

12.

$$x^2 - 36 = 0$$

$$x^2 = 36$$

$$\sqrt{x^2} = \sqrt{36}$$

$$x = \pm 6$$

13.

$$16x^2 - 49 = 0$$

$$16x^2 = 49$$

$$x^2 = 3.0625$$

$$\sqrt{x^2} = \sqrt{3.0625}$$

$$x = \pm 1.75$$

14.

$$(x - 2)^2 = 1$$

$$x - 2 = \sqrt{1}$$

$$x - 2 = \pm 1$$

$$x - 2 = 1$$

$$x = 3$$

$$x - 2 = -1$$

$$x = 1$$

$$x = 1, x = 3$$

15.

$$(x+5)^2 = 16$$

$$x+5 = \sqrt{16}$$

$$x+5 = \pm 4$$

$$x+5 = 4$$

$$x = -1$$

$$x+5 = -4$$

$$x = -9$$

$$x = -1, x = -9$$

16.

$$(2x-1)^2 - 4 = 0$$

$$(2x-1)^2 = 4$$

$$2x-1 = \sqrt{4}$$

$$2x-1 = \pm 2$$

$$2x-1 = 2$$

$$2x = 3$$

$$x = \frac{3}{2}$$

$$2x-1 = -2$$

$$2x = -1$$

$$x = -\frac{1}{2}$$

$$x = \frac{3}{2}, x = -\frac{1}{2}$$

17.

$$(3x + 4)^2 = 9$$

$$3x + 4 = \sqrt{9}$$

$$3x + 4 = \pm 3$$

$$3x + 4 = 3$$

$$3x = -1$$

$$3x = -\frac{1}{3}$$

$$3x + 4 = -3$$

$$3x = -7$$

$$x = -\frac{7}{3}$$

$$x = -\frac{1}{3}, x = -\frac{7}{3}$$

18.

$$(x - 3)^2 - 25 = 0$$

$$(x - 3)^2 = 25$$

$$x - 3 = \sqrt{25}$$

$$x - 3 = \pm 5$$

$$x - 3 = 5$$

$$x = 8$$

$$x - 3 = -5$$

$$x = -2$$

$$x = 8, x = -2$$

19.

$$x^2 - 6 = 0$$

$$x^2 = 6$$

$$\sqrt{x^2} = \sqrt{6}$$

$$x = \sqrt{6} \approx 2.4495$$

20.

$$x^2 - 20 = 0$$

$$x^2 = 20$$

$$\sqrt{x^2} = \sqrt{20}$$

$$x = \sqrt{4 \cdot 5}$$

$$x = 2\sqrt{5} \approx 4.4721$$

21.

$$3x^2 - 14 = 0$$

$$3x^2 = 14$$

$$x^2 = \frac{14}{3}$$

$$\sqrt{x^2} = \sqrt{\frac{14}{3}}$$

$$x = \sqrt{\frac{14}{3}} \approx 2.1602$$

22.

$$(x - 6)^2 = 5$$

$$x - 6 = \sqrt{5}$$

$$x = 6 + \sqrt{5} \approx 8.2361$$

23.

$$(4x+1)^2 - 8 = 0$$

$$(4x+1)^2 = 8$$

$$4x+1 = \sqrt{8}$$

$$4x = \sqrt{8} - 1$$

$$x = \frac{\sqrt{8} - 1}{4} = \frac{\sqrt{8}}{4} - \frac{1}{4} \approx 0.4571$$

24.

$$(x+10)^2 = 2$$

$$x+10 = \sqrt{2}$$

$$x = \sqrt{2} - 10 \approx -8.5858$$

25.

$$2(x+3)^2 = 8$$

$$(x+3)^2 = 4$$

$$x+3 = \sqrt{4}$$

$$x+3 = \pm 2$$

$$x+3 = 2$$

$$x = -1$$

$$x+3 = -2$$

$$x = -5$$

$$x = -1, x = -5$$

26.

$$h(t) = -\frac{1}{2}(g)t^2 + v_0t + h_0$$

$$0 = -\frac{1}{2}(32)t^2 + (0)t + 25$$

$$0 = -16t^2 + 25$$

$$-25 = -16t^2$$

$$25 = 16t^2$$

$$\sqrt{25} = \sqrt{16t^2}$$

$$\pm 5 = \pm 4t$$

$$5 = 4t$$

$$t = \frac{5}{4}$$

It takes 1.25 seconds for the ball to fall to the ground 25 feet below.

27.

$$h(t) = -\frac{1}{2}(g)t^2 + v_0t + h_0$$

$$h(t) = -\frac{1}{2}(32)t^2 + (0)t + 400$$

$$0 = -16t^2 + 400$$

$$16t^2 = 400$$

$$\sqrt{16t^2} = \sqrt{400}$$

$$\pm 4t = \pm 20$$

$$4t = 20$$

$$t = 5$$

Susan will hear the splash 5 seconds later.

28.

$$h(t) = -\frac{1}{2}(g)t^2 + v_0t + h_0$$

$$h(t) = -\frac{1}{2}(9.8)(5.3)^2 + (0)(5.3) + h_0$$

$$0 = -4.9(28.09) + h_0$$

$$0 = -137.641 + h_0$$

$$h_0 = 137.641$$

The cliff is 137.641 meters high.

29.

$$\begin{aligned}h(t) &= -\frac{1}{2}(g)t^2 + v_0t + h_0 & h(t) &= -\frac{1}{2}(g)t^2 + v_0t + h_0 \\h(t) &= -\frac{1}{2}(32)t^2 + (0)t + 50 & h(t) &= -\frac{1}{2}(32)t^2 + (0)t + 40 \\0 &= -16t^2 + 50 & 0 &= -16t^2 + 40 \\16t^2 &= 50 & 16t^2 &= 40 \\\sqrt{16t^2} &= \sqrt{50} & \sqrt{16t^2} &= \sqrt{40} \\4t &= \sqrt{25 \cdot 2} & 4t &= \sqrt{4 \cdot 10} \\4t &= 5\sqrt{2} & 4t &= 2\sqrt{10} \\t &= \frac{5\sqrt{2}}{4} & t &= \frac{2\sqrt{10}}{4} \\t &\approx 1.7677 & t &\approx 1.5811\end{aligned}$$

$1.5811 + 0.5 = 2.0811$
The rock Nisha dropped from the roof will hit the ground before the quarter Ashaan dropped from the top story window.

30.

$$\begin{aligned}h(t) &= -\frac{1}{2}(g)t^2 + v_0t + h_0 & h(t) &= -\frac{1}{2}(g)t^2 + v_0t + h_0 \\h(t) &= -\frac{1}{2}(32)t^2 + (0)t + 120 & h(t) &= -\frac{1}{2}(32)t^2 + (0)t + 72 \\0 &= -16t^2 + 120 & 0 &= -16t^2 + 72 \\16t^2 &= 120 & 16t^2 &= 72 \\\sqrt{16t^2} &= \sqrt{120} & \sqrt{16t^2} &= \sqrt{72} \\4t &= \sqrt{4 \cdot 30} & 4t &= \sqrt{9 \cdot 8} \\4t &= 2\sqrt{30} & 4t &= 3\sqrt{8} \\t &= \frac{2\sqrt{30}}{4} & t &= \frac{3\sqrt{8}}{4} \\t &\approx 2.7386 & t &\approx 2.1213\end{aligned}$$

$2.1213 + 1 = 3.1213$
The apple dropped by Victor off the tenth floor will hit the ground before the orange dropped by Juan off the sixth floor. The time difference is $3.1213 - 2.7386 = 0.3827$ of a second.

Mixed Review

31.

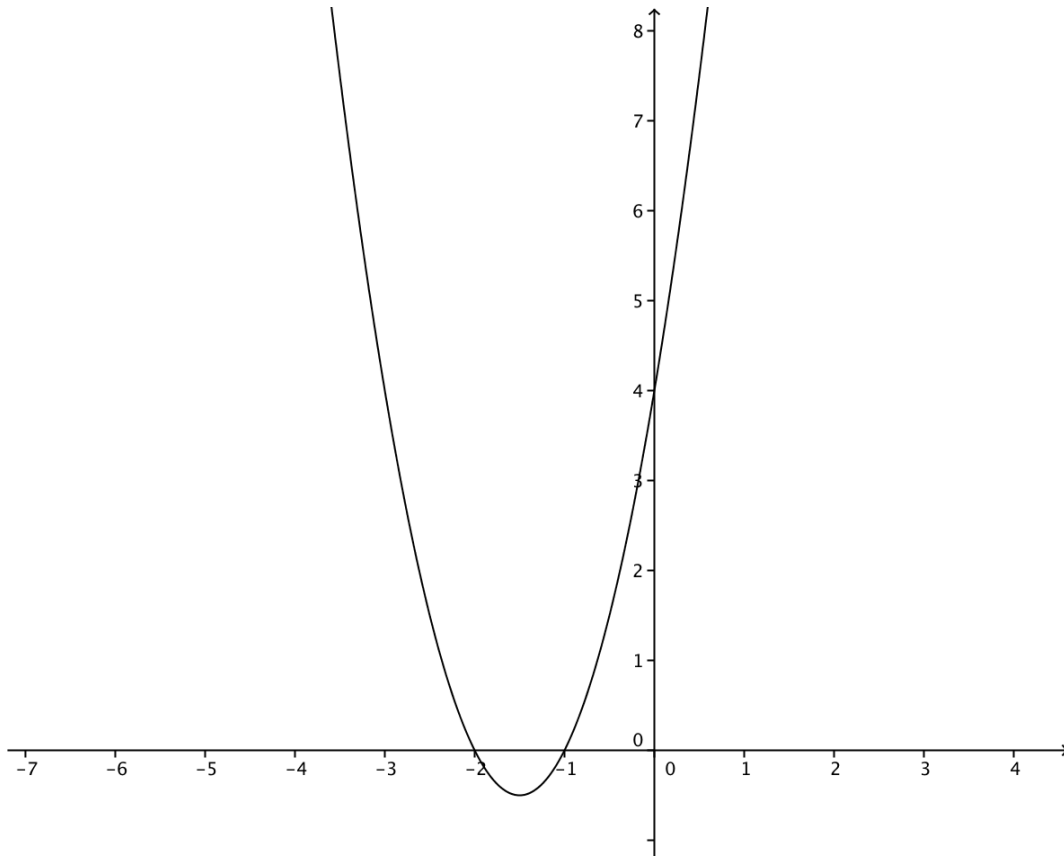

1. vertex $(-1.5, -0.5)$
2. x-intercepts = $-1, -2$
3. y-intercept = 4
4. axis of symmetry : $x = -1.5$

32.

$y=x+3$ (This is a linear equation that results in a line.)

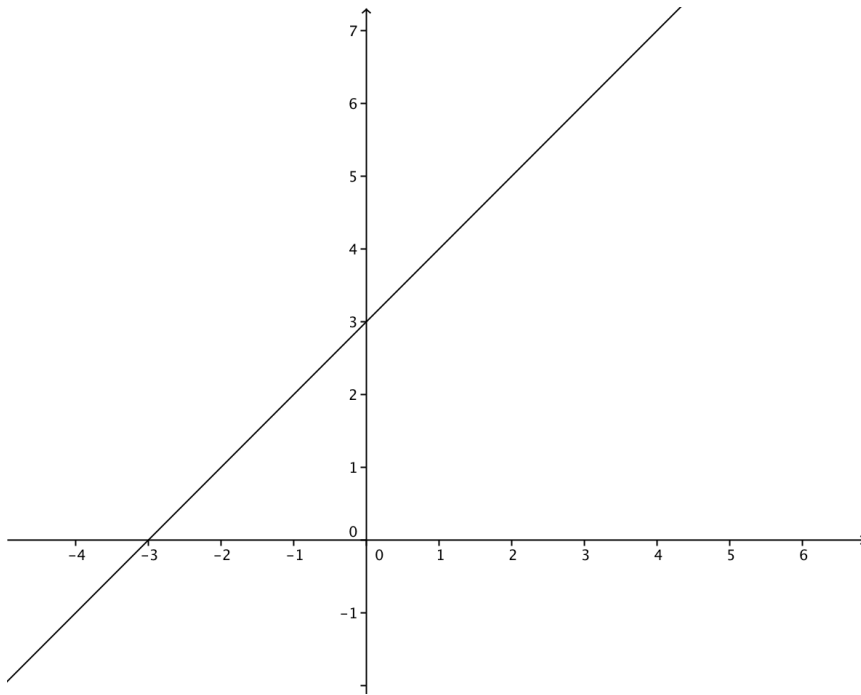

$y=x^2+3$ (This equation is a quadratic that results in a parabola.)

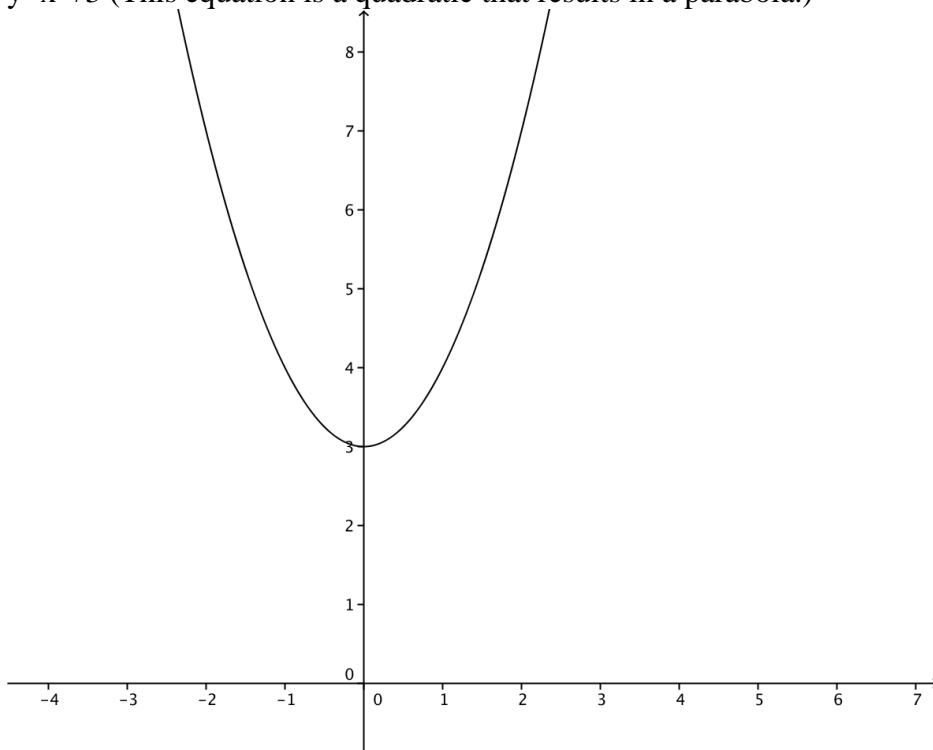

33.

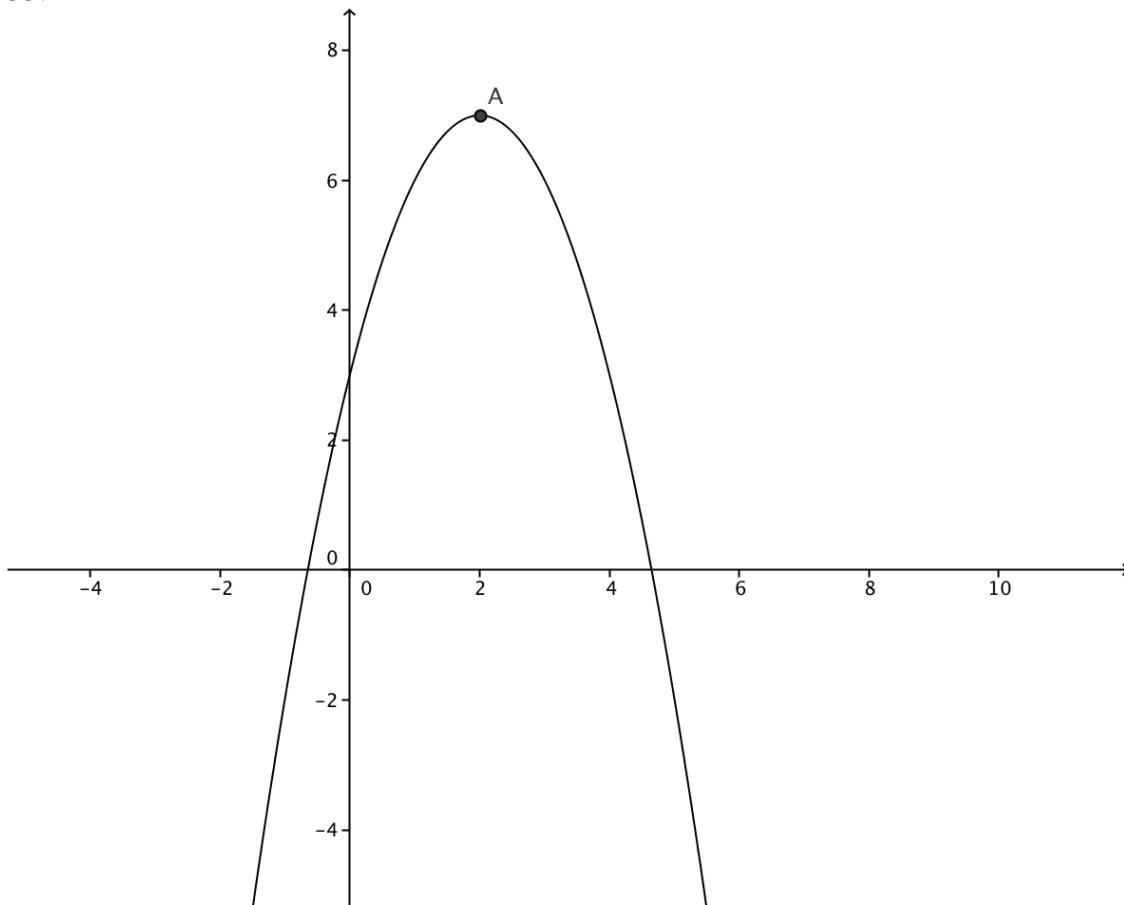

domain = all real numbers

range = all real numbers less than or equal to 7

34.

h = the price of a hot dog

s = the price of a soda

Friday the club sells 112 times h and 70 times s to equal 154 ($112h+70s=154$)

Saturday the club sells 240 times h and 120 times s to equal 300 ($240h +120s=300$)

Now let's solve the system.

$$\begin{cases} 112h + 70s = 154 \\ 240h + 120s = 300 \end{cases}$$

$$240h + 120s = 300$$

$$120s = 300 - 240h$$

$$s = 2.5 - 2h$$

$$112h + 70s = 154$$

$$112h + 70(2.5 - 2h) = 154$$

$$112h + 175 - 140h = 154$$

$$175 - 28h = 154$$

$$-28h = -21$$

$$h = 0.75$$

$$240h + 120s = 300$$

$$240(0.75) + 120s = 300$$

$$180 + 120s = 300$$

$$120s = 120$$

$$s = 1$$

Hot dog cost \$0.75 each and sodas cost \$1.00 each.

Lesson 10.4

Solving Quadratic Equations by Completing the Square

1. “Completing the square” is the term used for turning a quadratic equation into a perfect square trinomial by adding or subtracting terms on both sides.

2. In order to change a quadratic equation into a perfect square trinomial (complete the square) one must do the following.

- recognize that the third term is missing

- utilize the formula for a perfect square $(a^2 + 2(ab) + b^2)$ to determine that the leading coefficient (a) will be x (if there is a coefficient in front of x, divide all terms on both sides by that number to get x alone)

- Now use the same formula to find $2(ab)$ or $2xb$ by setting the middle term equal to $2xb$ and solving the equation for b.

- We can also find b by dividing the coefficient of x in the middle term by 2, this also gives us b

- find the square of b (b^2) and place it as the third term in the equation

- check by ensuring that the equation factors to $(a+b)^2$

3.

$$h(t) = -\frac{1}{2}(g)t^2 + v_0t + h_0$$

$$h(t) = -\frac{1}{2}(9.8)t^2 + (50)t + 2$$

$$h(t) = -4.9t^2 + 50t + 2$$

a)

$$h(t) = -4.9t^2 + 50t + 2$$

$$h(4) = -4.9(4^2) + 50(4) + 2$$

$$h(4) = -4.9(16) + 200 + 2$$

$$h(4) = -78.4 + 202$$

$$h(4) = 123.6$$

$$h(t) = -4.9t^2 + 50t + 2$$

$$h(8) = -4.9(8^2) + 50(8) + 2$$

$$h(8) = -4.9(64) + 400 + 2$$

$$h(8) = -313.6 + 402$$

$$h(8) = 88.4$$

The height of the arrow after 4 seconds will be 123.6 meters. After 8 seconds the height of the arrow will be 88.4 meters.

b)

$$h(t) = -4.9t^2 + 50t + 2$$

$$0 = -4.9t^2 + 50t + 2$$

$$0 = t^2 - \frac{500}{49}t - \frac{20}{49}$$

$$\frac{20}{49} = t^2 - \frac{500}{49}t$$

$$\frac{20}{49} + \frac{62500}{2401} = t^2 - \frac{500}{49}t + \frac{62500}{2401}$$

$$\frac{63480}{2401} = \left(t - \frac{250}{49}\right)^2$$

$$\sqrt{\frac{63480}{2401}} = \left(t - \frac{250}{49}\right)$$

$$5.1419 \approx t - 5.1020$$

$$t \approx 10.2439$$

The arrow will hit the ground after approximately 10.2439 seconds.

4.

$$y = a(x - h)^2 + k$$

5.

$$y = a(x - h)^2 + k$$

$$y = \frac{1}{3}(x - 1)^2 + 1$$

6.

$$y = a(x - h)^2 + k$$

$$y = -2(x - (-5))^2 + 0$$

$$y = -2(x + 5)^2$$

7.

$$y = a(x - h)^2 + k$$

$$y = 1(x - 1)^2 + -2$$

$$y = (x - 1)^2 + -2$$

8.

$$y = a(x - h)^2 + k$$

$$y = 1(x - (-3))^2 + 6$$

$$y = (x + 3)^2 + 6$$

9.

$$x^2 + 5x$$

$$b = \frac{5}{2} = 2.5$$

$$b^2 = 6.25$$

$$x^2 + 5x + 6.25$$

$$(x + 2.5)^2$$

10.

$$x^2 - 2x$$

$$b = -\frac{2}{2} = -1$$

$$b^2 = 1$$

$$x^2 - 2x + 1$$

$$(x - 1)^2$$

11.

$$x^2 + 3x$$

$$b = \frac{3}{2} = 1.5$$

$$b^2 = 2.25$$

$$x^2 + 3x + 2.25$$

$$(x + 1.5)^2$$

12.

$$x^2 - 4x$$

$$b = -\frac{4}{2} = -2$$

$$b^2 = 4$$

$$x^2 - 4x + 4$$

$$(x - 2)^2$$

13.

$$3x^2 + 18x$$

$$\frac{3}{3}x^2 + \frac{18}{3}x = \frac{0}{3}$$

$$x^2 + 6x = 0$$

$$b = \frac{6}{2} = 3$$

$$b^2 = 9$$

$$x^2 + 6x + 9$$

$$(x + 3)^2$$

$$3x^2 + 18x + 27$$

$$3(x + 3)^2$$

14.

$$2x^2 - 22x$$

$$\frac{2}{2}x^2 - \frac{22}{2}x = \frac{0}{2}$$

$$x^2 - 11x = 0$$

$$b = -\frac{11}{2} = -5.5$$

$$b^2 = 30.25$$

$$x^2 - 11x + 30.25$$

$$(x - 5.5)^2$$

$$2x^2 - 22x + 60.5$$

$$2(x - 5.5)^2$$

15.

$$8x^2 - 10x$$

$$\frac{8}{8}x^2 - \frac{10}{8}x = \frac{0}{8}$$

$$x^2 - 1.25x = 0$$

$$b = -1.25 / 2 = -0.625$$

$$b^2 = 0.390625$$

$$x^2 - 1.25x + 0.390625$$

$$(x - 0.625)^2$$

$$8x^2 - 10x + 3.125$$

$$8(x - 0.625)^2$$

16.

$$5x^2 + 12x$$

$$\frac{5}{5}x^2 + \frac{12}{5}x = \frac{0}{5}$$

$$x^2 + 2.4x = 0$$

$$b = 2.4 / 2 = 1.2$$

$$b^2 = 1.44$$

$$x^2 + 2.4x + 1.44$$

$$(x + 1.2)^2$$

$$5x^2 + 12x + 7.2$$

$$5(x + 1.2)^2$$

17.

$$x^2 - 4x = 5$$

$$x^2 - 4x + 4 = 5 + 4$$

$$x^2 - 4x + 4 = 9$$

$$(x - 2)^2 = 9$$

$$x - 2 = \sqrt{9}$$

$$x - 2 = \pm 3$$

$$x - 2 = 3$$

$$x = 5$$

$$x - 2 = -3$$

$$x = -1$$

$$x = -1, 5$$

18.

$$x^2 - 5x = 10$$

$$x^2 - 5x + 6.25 = 10 + 6.25$$

$$(x - 2.5)^2 = 16.25$$

$$x - 2.5 = \sqrt{16.25}$$

$$x = 2.5 + \sqrt{16.25}$$

$$x \approx 2.5 \pm 4.0311$$

$$x \approx 2.5 + 4.0311$$

$$x \approx 6.5311$$

$$x \approx 2.5 - 4.0311$$

$$x \approx -1.5311$$

19.

$$x^2 + 10x + 15 = 0$$

$$x^2 + 10x = -15$$

$$x^2 + 10x + 25 = -15 + 25$$

$$x^2 + 10x + 25 = 10$$

$$(x - 5)^2 = 10$$

$$x - 5 = \sqrt{10}$$

$$x = 5 + \sqrt{10}$$

$$x \approx 5 \pm 3.1623$$

$$x \approx 5 + 3.1623$$

$$x \approx 8.1623$$

$$x \approx 5 - 3.1623$$

$$x \approx 1.8377$$

20.

$$x^2 + 15x + 20 = 0x$$

$$x^2 + 15x = -20$$

$$x^2 + 15x + 56.25 = -20 + 56.25$$

$$x^2 + 15x + 56.25 = 36.25$$

$$(x - 7.5)^2 = 36.25$$

$$x - 7.5 = \sqrt{36.25}$$

$$x = \sqrt{36.25} + 7.5$$

$$x \approx \pm 6.0208 + 7.5$$

$$x \approx 6.0208 + 7.5$$

$$x \approx 13.5208$$

$$x \approx -6.0208 + 7.5$$

$$x \approx 1.4792$$

21.

$$2x^2 - 18x = 0$$

$$x^2 - 9x = 0$$

$$x^2 - 9x + 20.25 = 20.25$$

$$(x - 4.5)^2 = 20.25$$

$$x - 4.5 = \sqrt{20.25}$$

$$x = \sqrt{20.25} + 4.5$$

$$x = \pm 4.5 + 4.5$$

$$x = 4.5 + 4.5$$

$$x = 9$$

$$x = -4.5 + 4.5$$

$$x = 0$$

22.

$$4x^2 + 5x = -1$$

$$x^2 + \frac{5}{4}x = -\frac{1}{4}$$

$$x^2 + \frac{5}{4}x + \frac{25}{64} = -\frac{1}{4} + \frac{25}{64}$$

$$x^2 + \frac{5}{4}x + \frac{25}{64} = \frac{9}{64}$$

$$\left(x - \frac{5}{8}\right)^2 = \frac{9}{64}$$

$$x - \frac{5}{8} = \sqrt{\frac{9}{64}}$$

$$x = \frac{5}{8} + \sqrt{\frac{9}{64}}$$

$$x = .625 \pm .375$$

$$x = .625 + .375$$

$$x = 1$$

$$x = .625 - .375$$

$$x = .25$$

23.

$$10x^2 - 30x - 8 = 0$$

$$x^2 - 3x - .8 = 0$$

$$x^2 - 3x = .8$$

$$x^2 - 3x + 2.25 = .8 + 2.25$$

$$x^2 - 3x + 2.25 = 3.05$$

$$(x - 1.5)^2 = 3.05$$

$$x - 1.5 = \sqrt{3.05}$$

$$x = 1.5 + \sqrt{3.05}$$

$$x \approx 1.5 \pm 1.7464$$

$$x \approx 1.5 + 1.7464$$

$$x \approx 3.2464$$

$$x \approx 1.5 - 1.7464$$

$$x \approx -0.2464$$

24.

$$5x^2 + 15x - 40 = 0$$

$$x^2 + 3x - 8 = 0$$

$$x^2 + 3x = 8$$

$$x^2 + 3x + 2.25 = 8 + 2.25$$

$$(x - 1.5)^2 = 10.25$$

$$x - 1.5 = \sqrt{10.25}$$

$$x = 1.5 + \sqrt{10.25}$$

$$x \approx 1.5 \pm 3.2016$$

$$x \approx 1.5 + 3.2016$$

$$x \approx 4.7016$$

$$x \approx 1.5 - 3.2016$$

$$x \approx -1.7016$$

25.

$$y = x^2 - 6x$$

$$y + 9 = x^2 - 6x + 9$$

$$y + 9 = (x - 3)^2$$

$$y = (x - 3)^2 - 9$$

26.

$$y + 1 = -2x^2 - x$$

$$y = -2x^2 - x - 1$$

$$y = -2\left(x^2 + \frac{1}{2}x + \frac{1}{2}\right)$$

$$y = -2\left(x^2 + \frac{1}{2}x + \frac{1}{16}\right) + \frac{1}{2}(-2) - \frac{1}{16}(-2)$$

$$y = -2\left(x^2 + \frac{1}{4}\right)^2 - 1 + \frac{2}{16}$$

$$y = -2\left(x^2 + \frac{1}{4}\right)^2 - 1 + \frac{1}{8}$$

$$y = -2\left(x^2 + \frac{1}{4}\right)^2 - \frac{8}{8} + \frac{1}{8}$$

$$y = -2\left(x^2 + \frac{1}{4}\right)^2 - \frac{7}{8}$$

27.

$$y = 9x^2 + 3x - 10$$

$$y = 9\left(x^2 + \frac{1}{6}x - \frac{10}{9}\right)$$

$$y = 9\left(x^2 + \frac{1}{6}x + \frac{1}{36}\right) - \frac{10}{9}(9) - \frac{1}{36}(9)$$

$$y = 9\left(x + \frac{1}{6}\right)^2 - 10 - \frac{9}{36}$$

$$y = 9\left(x + \frac{1}{6}\right)^2 - 10 - \frac{3}{12}$$

$$y = 9\left(x + \frac{1}{6}\right)^2 - \frac{120}{12} - \frac{3}{12}$$

$$y = 9\left(x + \frac{1}{6}\right)^2 - \frac{123}{12}$$

$$y = 9\left(x + \frac{1}{6}\right)^2 - \frac{41}{4}$$

28.

$$y = 32x^2 + 60x + 10$$

$$y = 32\left(x^2 + \frac{60}{32}x + \frac{10}{32}\right)$$

$$y = 32\left(x^2 + \frac{60}{32}x + \frac{900}{1024}\right) + \frac{900}{1024}(32) + \frac{10}{32}(32)$$

$$y = 32\left(x + \frac{30}{32}\right)^2 - \frac{900}{1024}(32) + 10$$

$$y = 32\left(x + \frac{30}{32}\right)^2 - \frac{28800}{1024} + 10$$

$$y = 32\left(x + \frac{15}{16}\right)^2 - 28.125 + 10$$

$$y = 32\left(x + \frac{15}{16}\right)^2 - 18.125$$

29. $y - 4 = x^2 + 8x$

1. vertex $(-4, -12)$
2. x-intercepts $(-7.46, 0)$ $(-0.54, 0)$
3. y-intercept $(0, 4)$
4. The parabola opens up.
- 5.

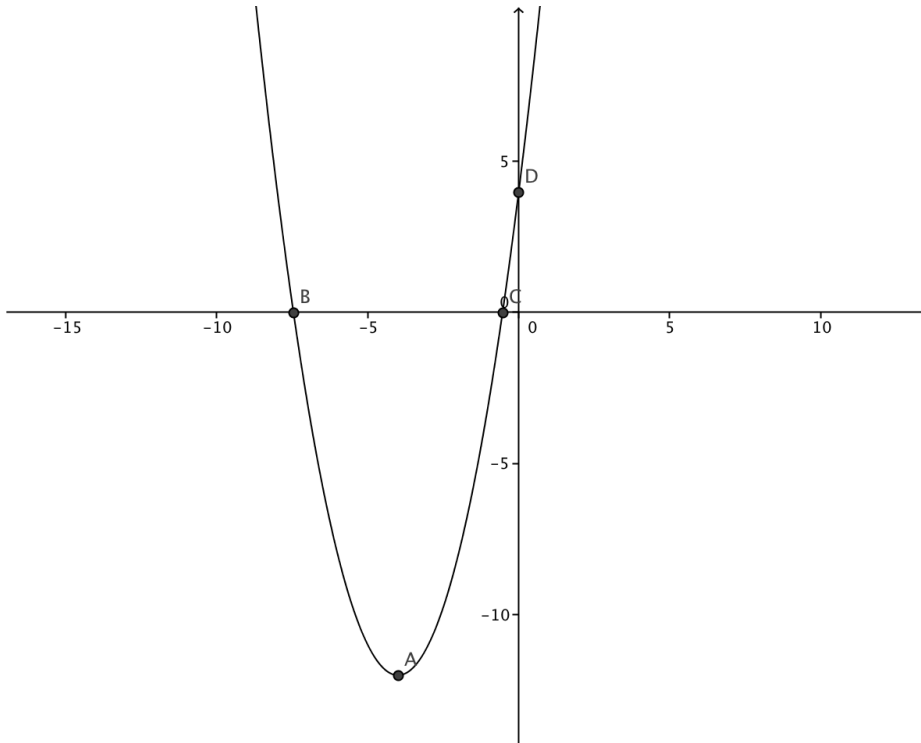

30. $y = -4x^2 + 20x - 24$

1. vertex (2.5,1)
2. x-intercepts (2,0) (3,0)
3. y-intercept (0,-24)
4. The parabola opens down.
- 5.

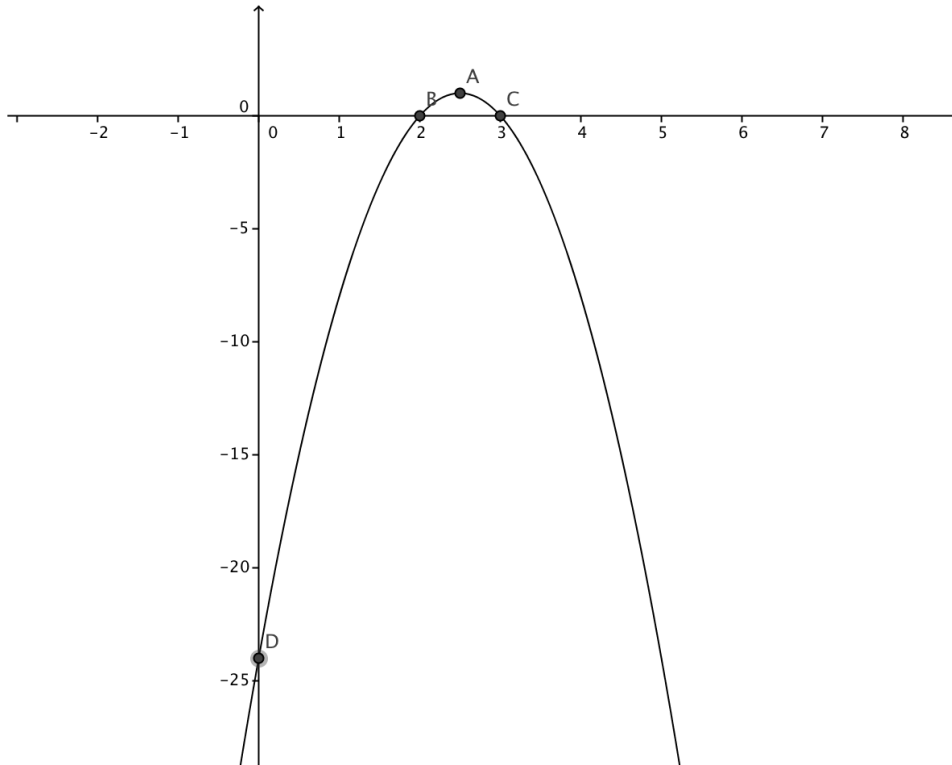

31. $y = 3x^2 + 15x$

1. vertex (0,15)
2. x-intercepts NONE
3. y-intercept (0,15)
4. The parabola opens up.
- 5.

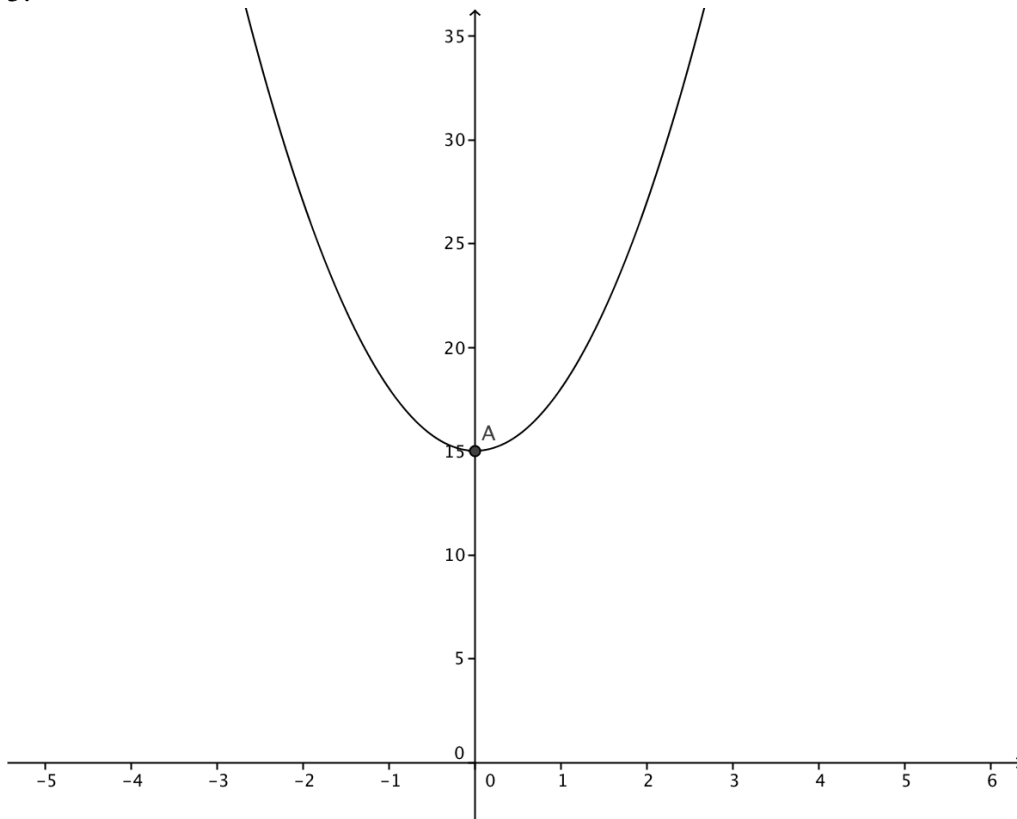

32. $y + 6 = -x^2 + x$

1. vertex $(0.5, -5.75)$
2. x-intercepts NONE
3. y-intercept $(0, -6)$
4. The parabola opens down.
- 5.

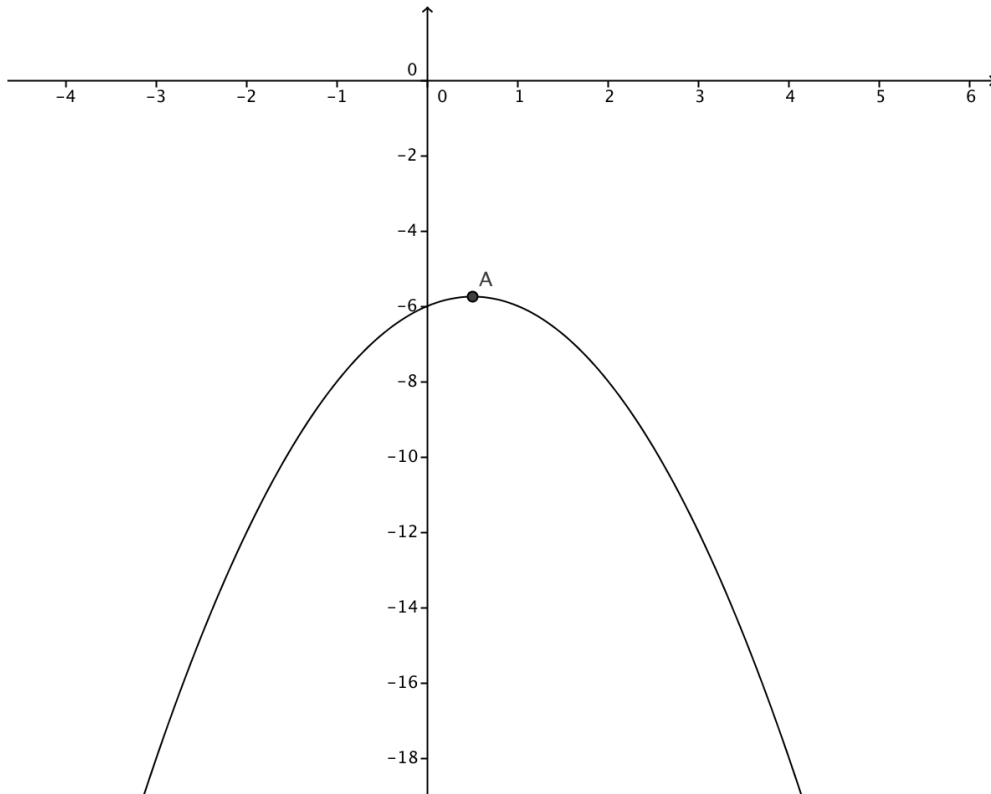

33. $x^2 - 10x + 25 = 9$

1. vertex (5,-9)
2. x-intercepts (2,0) (8,0)
3. y-intercept (0,16)
4. The parabola opens up .
- 5.

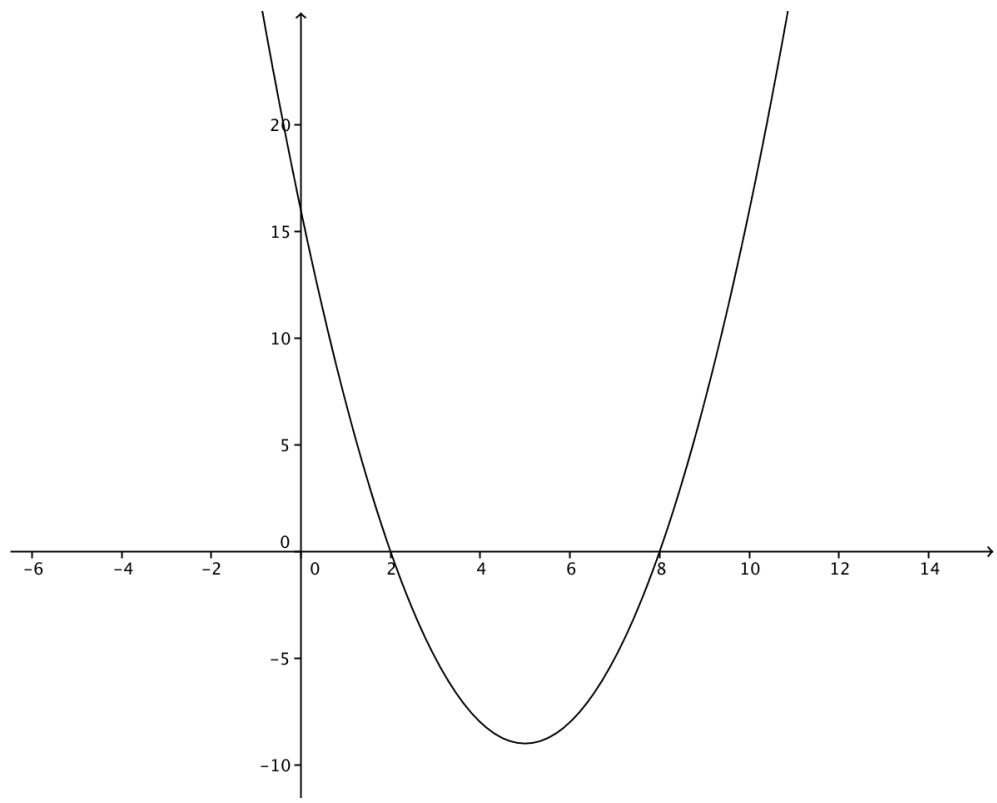

34. $x^2 + 18x + 81 = 1$

1. vertex $(-9, -1)$
2. x-intercepts $(-10, 0)$ $(-8, 0)$
3. y-intercept $(0, 80)$
4. The parabola opens up.
- 5.

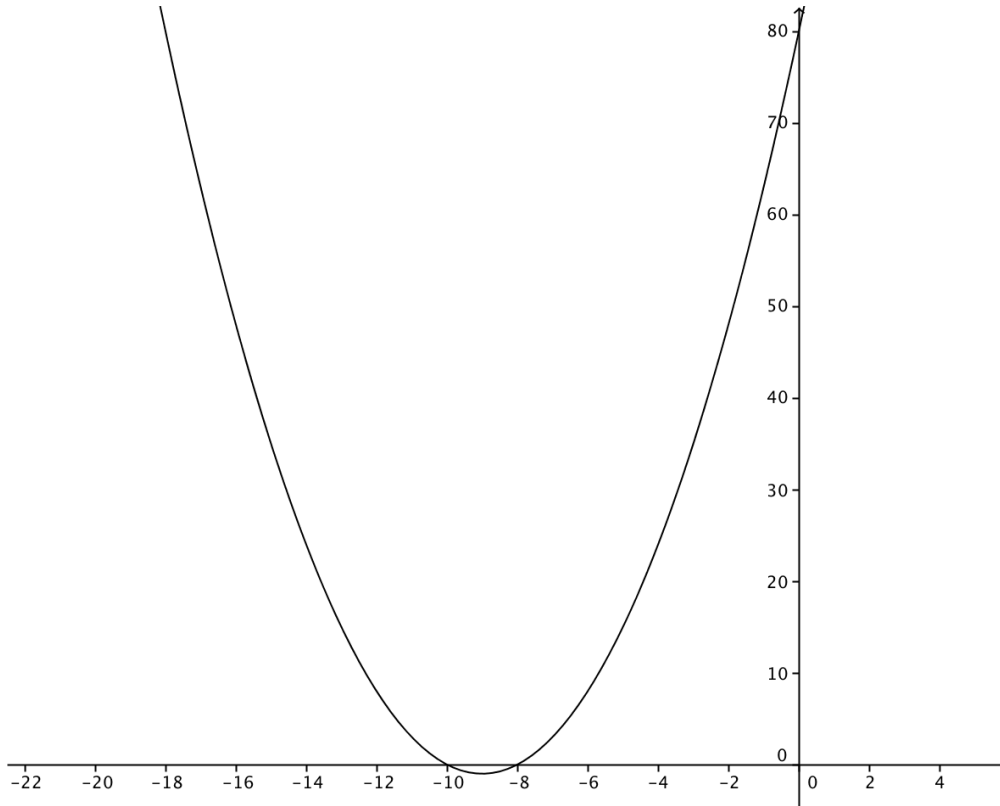

35. $4x^2 - 12x + 9 = 16$

1. vertex (1.5,-16)
2. x-intercepts (-0.5,0) (3.5,0)
3. y-intercept (0,-7)
4. The parabola opens up.
- 5.

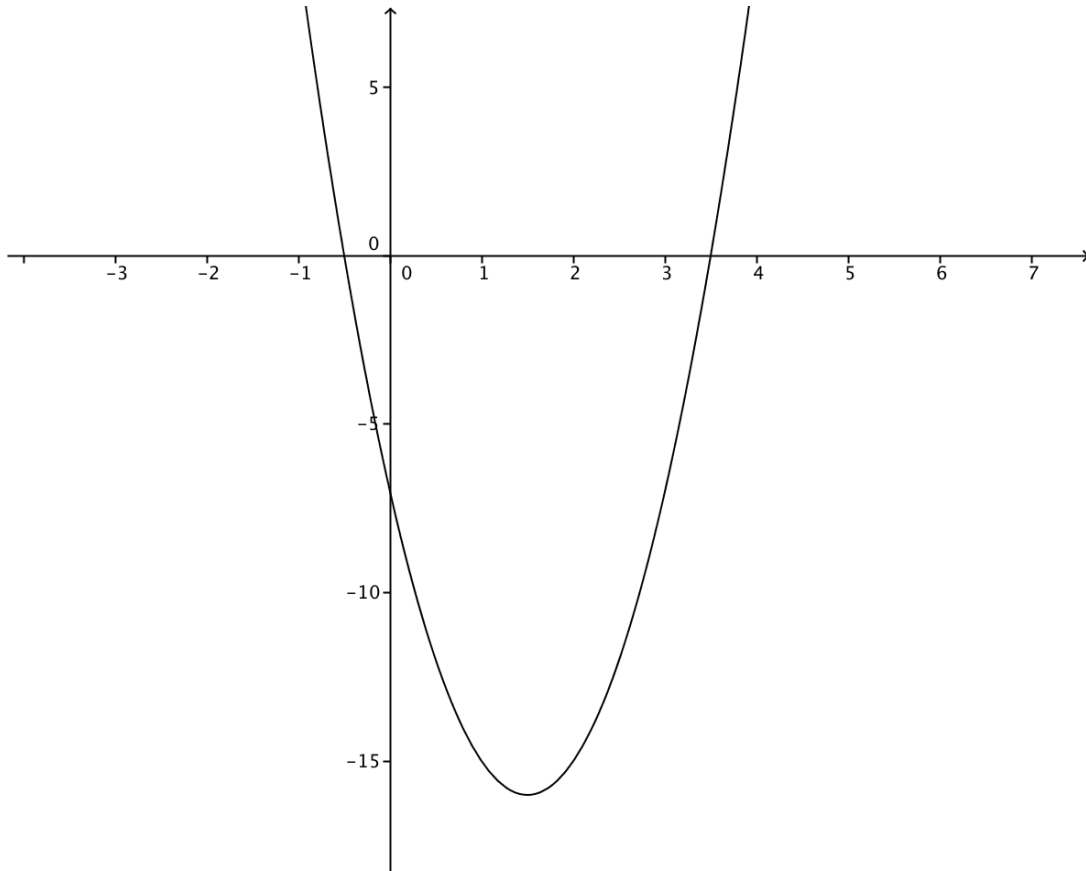

36. $x^2 + 14x + 49 = 3$

1. vertex $(-7, -3)$
2. x-intercepts $(-8.732, 0)$ $(-5.268, 0)$
3. y-intercept $(0, 46)$
4. The parabola opens up.
- 5.

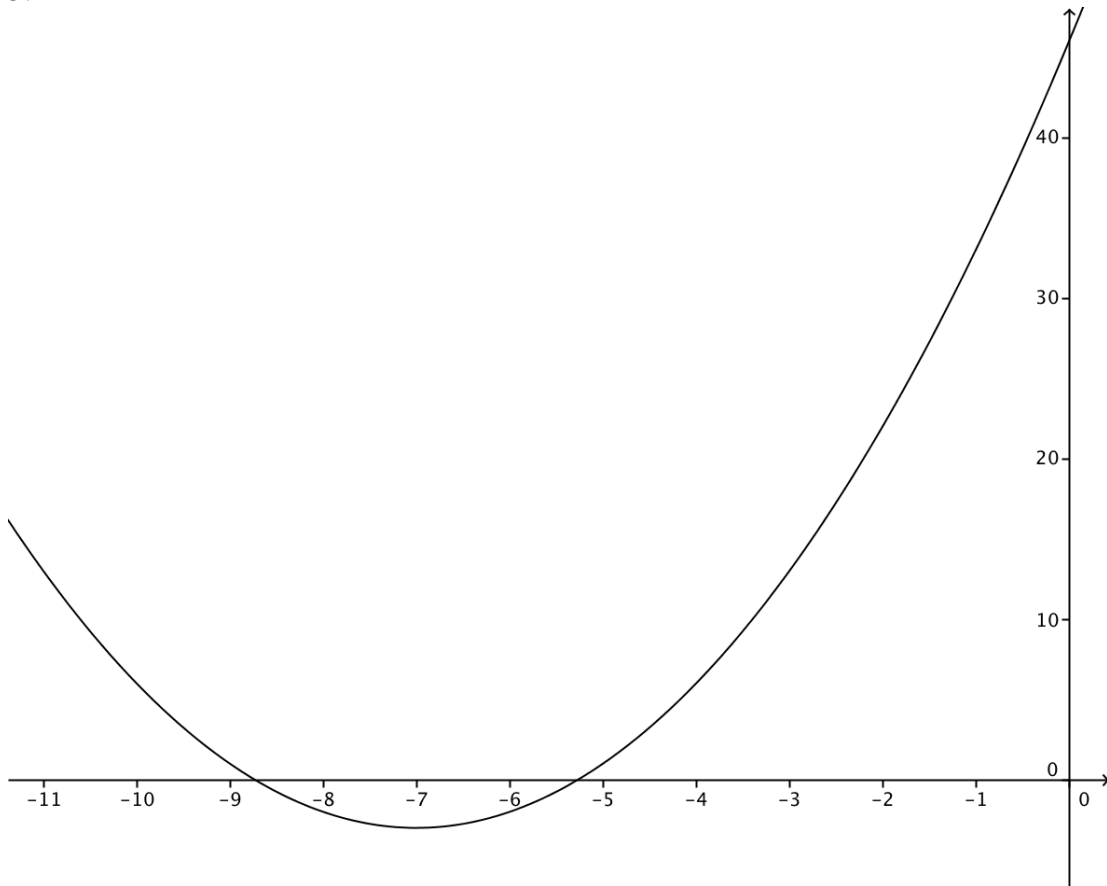

37. $4x^2 - 20x + 25 = 9$

1. vertex (2.5,-9)
2. x-intercepts (1,0) (4,0)
3. y-intercept (0,16)
4. The parabola opens up.
- 5.

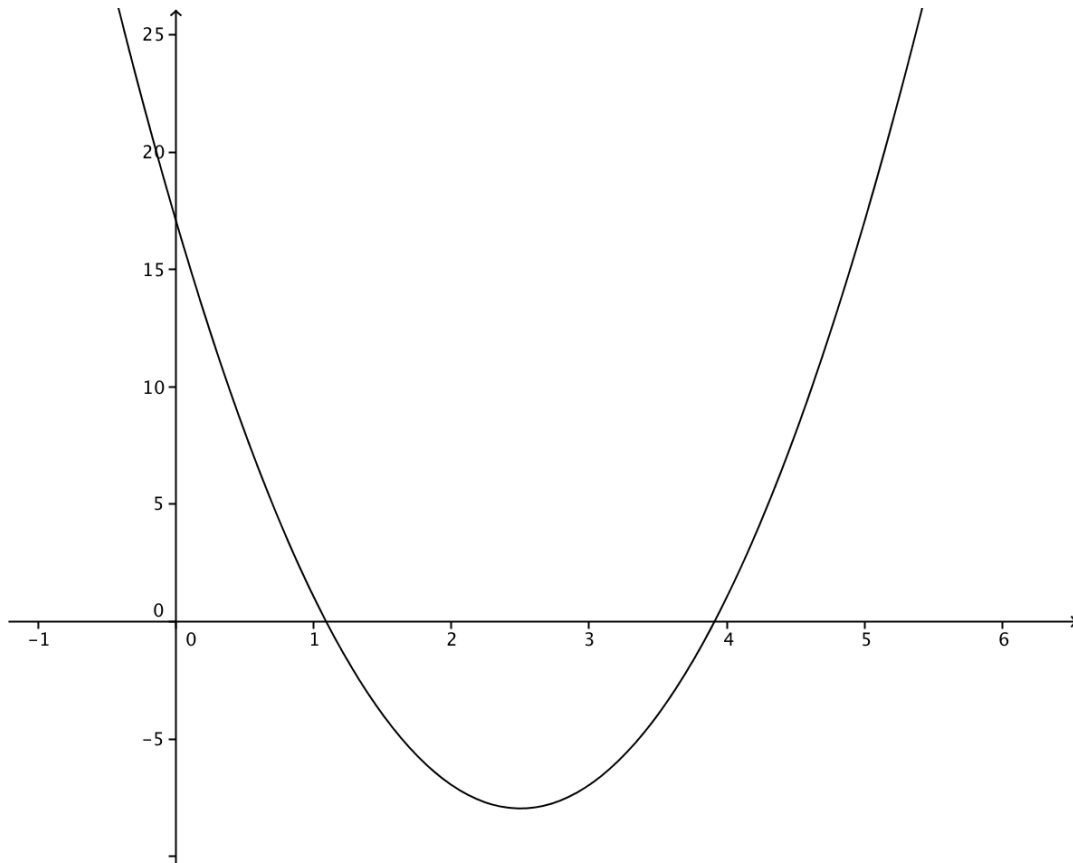

38. $x^2 + 8x + 16 = 25$

1. vertex $(-4, -25)$
2. x-intercepts $(-9, 0)$ $(1, 0)$
3. y-intercept $(0, -9)$
4. The parabola opens up.
- 5.

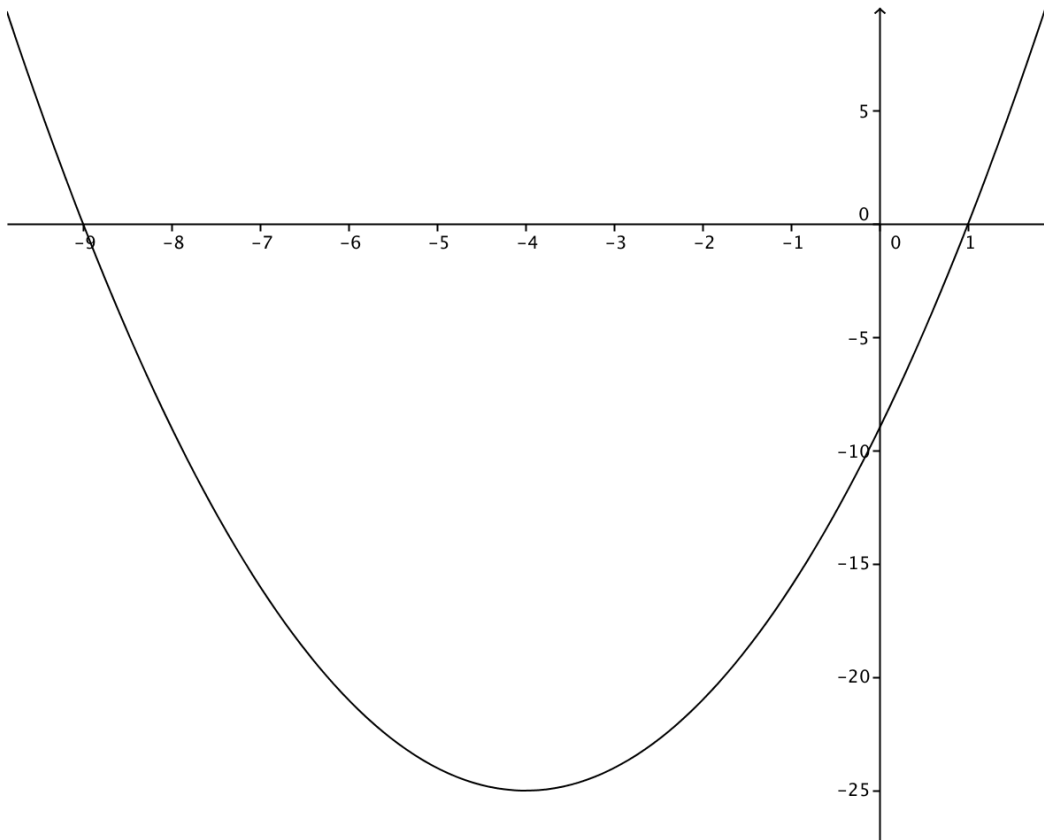

39.

$$h(t) = -\frac{1}{2}(g)t^2 + v_0t + h_0$$

$$h(t) = -\frac{1}{2}(32)t^2 + 16t + 25$$

$$h(t) = -16t^2 + 16t + 25$$

$$0 = -16t^2 + 16t + 25$$

$$0 - 25 = -16t^2 + 16t$$

$$-25 = -16t^2 + 16t$$

$$-25 = -16(t^2 - t)$$

$$-25 + \frac{1}{4}(-16) = -16\left(t^2 - t + \frac{1}{4}\right)$$

$$-25 - 4 = -16\left(t - \frac{1}{2}\right)^2$$

$$-29 = -16\left(t - \frac{1}{2}\right)^2$$

$$-29 \div -16 = \left(t - \frac{1}{2}\right)^2$$

$$\frac{29}{16} = \left(t - \frac{1}{2}\right)^2$$

$$\sqrt{\frac{29}{16}} = \sqrt{\left(t - \frac{1}{2}\right)^2}$$

$$\frac{\sqrt{29}}{4} = t - \frac{1}{2}$$

$$t = \frac{\sqrt{29}}{4} + \frac{1}{2}$$

$$t = \frac{\sqrt{29}}{4} + \frac{2}{4}$$

$$t \approx 1.8463$$

40.

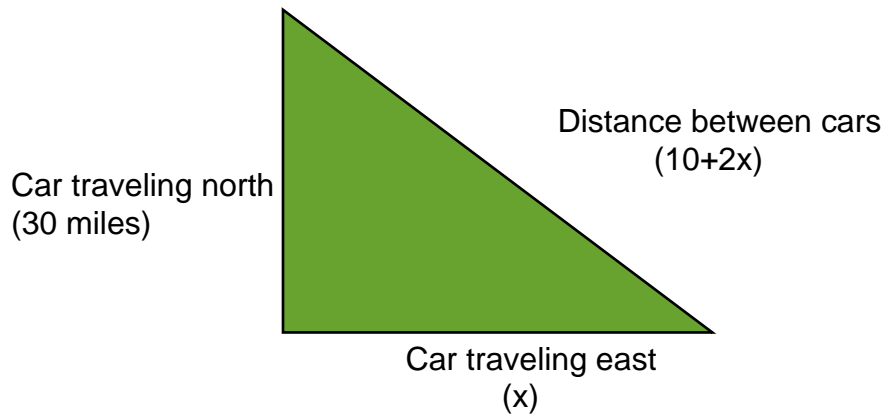

If the car traveling north goes 30 miles and the car traveling east goes x and the distance between the two cars is $10+2x$, then it creates the right triangle above. We can find the distance between the two cars (the hypotenuse) by using the pythagorean theorem.

$$a^2 + b^2 = c^2$$

$$x^2 + 30^2 = (10 + 2x)^2$$

$$x^2 + 900 = 4x^2 + 40x + 100$$

$$900 = 3x^2 + 40x + 100$$

$$0 = 3x^2 + 40x - 800$$

$$0 = 3\left(x^2 + \frac{40}{3}x - \frac{800}{3}\right)$$

$$0 = 3\left(x^2 + \frac{40}{3}x + \frac{400}{9}\right) - \frac{400}{9}(3) - \frac{800}{3}(3)$$

$$0 = 3\left(x + \frac{20}{3}\right)^2 - \frac{400}{3} - 800$$

$$0 = 3\left(x + \frac{20}{3}\right)^2 - \frac{2800}{3}$$

$$\frac{2800}{3} = 3\left(x + \frac{20}{3}\right)^2$$

$$\frac{2800}{3} \div 3 = \left(x + \frac{20}{3}\right)^2$$

$$\frac{2800}{9} = \left(x + \frac{20}{3}\right)^2$$

$$\sqrt{\frac{2800}{9}} = \sqrt{\left(x + \frac{20}{3}\right)^2}$$

$$\frac{\sqrt{2800}}{3} = x + \frac{20}{3}$$

$$x = \frac{\sqrt{2800}}{3} - \frac{20}{3}$$

$$x \approx 10.9717$$

$$c = 10 + 2x$$

$$c = 10 + 2(10.9717)$$

$$c = 10 + 21.9434$$

$$c = 31.9434$$

The distance between the two cars is approximately 31.9434 miles.

41.

Distance walked by Amanda in 1/2 an hour
(x)

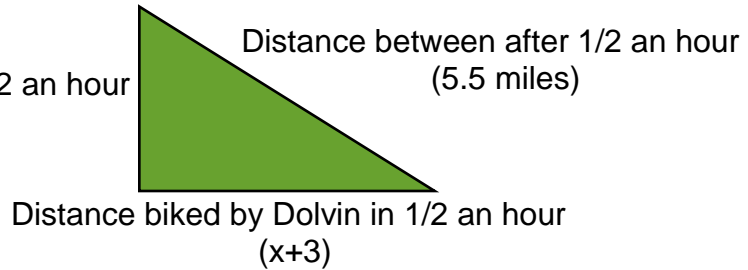

If the distance walked by Amanda is x and the distance biked by Dolvin is $x+3$, with the distance between them being 5.5 miles, we have the right triangle seen above. We can use the pythagorean theorem to find x and determine the distances traveled by Amanda and Dolvin.

$$a^2 + b^2 = c^2$$

$$x^2 + (x + 3)^2 = (5.5)^2$$

$$x^2 + (x^2 + 6x + 9) = 30.25$$

$$2x^2 + 6x + 9 - 30.25 = 0$$

$$2x^2 + 6x - 21.25 = 0$$

$$2(x^2 + 3x - 10.625) = 0$$

$$2(x^2 + 3x + 2.25) + 2.25(2) - 10.625(2)$$

$$2(x + 1.5)^2 + 4.5 - 21.25 = 0$$

$$2(x + 1.5)^2 - 16.75 = 0$$

$$2(x + 1.5)^2 = 16.75$$

$$(x + 1.5)^2 = 8.375$$

$$\sqrt{(x + 1.5)^2} = \sqrt{8.375}$$

$$x + 1.5 = \sqrt{8.375}$$

$$x = \sqrt{8.375} - 1.5$$

$$x \approx 1.3940$$

$$b = x + 3$$

$$b = 1.394 + 3$$

$$b = 4.394$$

Amanda walked approximately 1.394 miles and Dolvin biked approximately 4.394 miles.

Mixed Review

42.

Original Height	1st Bounce	2nd Bounce	3rd Bounce	4th Bounce	5th Bounce
4ft	2.8ft	1.96 ft	1.372 ft	0.9604 ft	0.6723 ft

The ball will reach a height of 0.2306 ft on the 8th bounce.

43.

$$y = \frac{2}{7}x - 11$$

$$-\frac{2}{7}x + y = 11$$

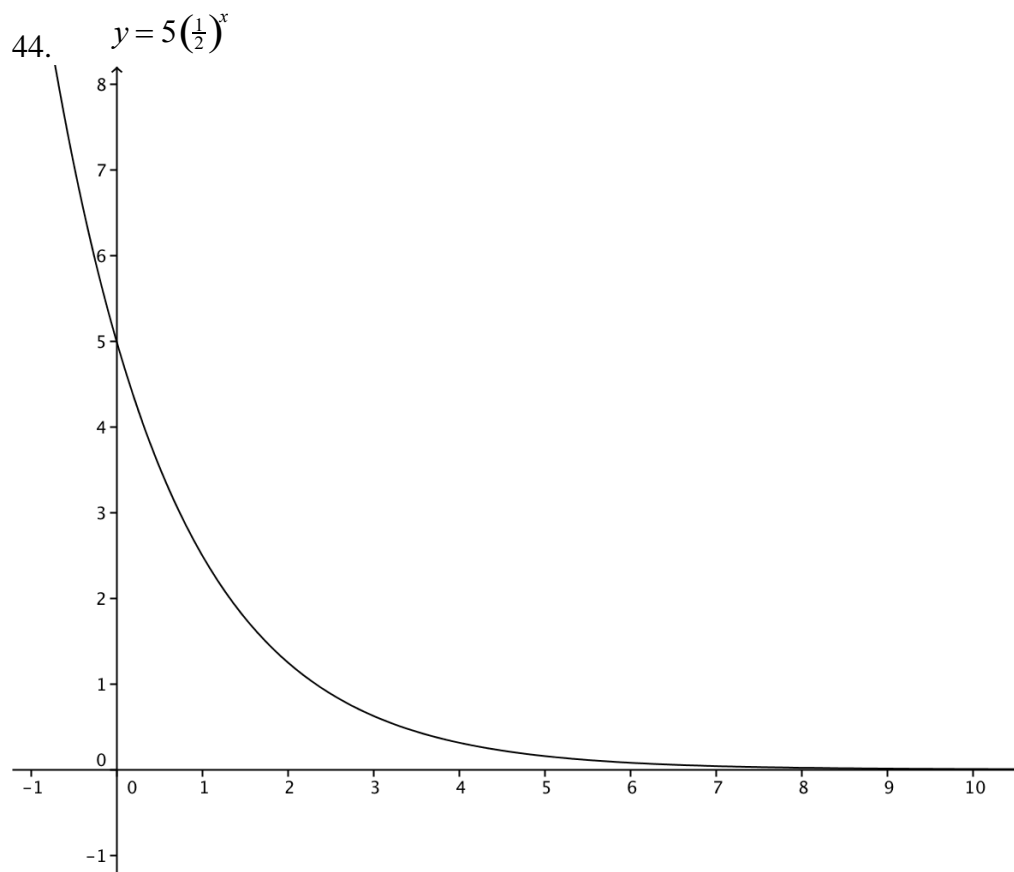

This is exponential decay. The growth(decay) factor is $1/2$.

45.

$$|3r - 4| \leq 2$$

$$3r - 4 \leq 2$$

$$3r \leq 6$$

$$r \leq 6$$

$$3r - 4 \geq -2$$

$$3r \geq 2$$

$$r \geq \frac{2}{3}$$

$$\frac{2}{3} \leq r \leq 6$$

46.

$$-2m + 6 = -8(5m + 4)$$

$$-2m + 6 = -40m - 32$$

$$-2m = -40m - 32 - 6$$

$$-2m + 40m = -38$$

$$38m = -38$$

$$m = -1$$

47.

$$4a^2 + 36a - 40$$

$$4(a^2 + 9a - 10)$$

$$4(a + 10)(a - 1)$$

Quick Quiz

1. $y = -3x^2 - 12x - 13$

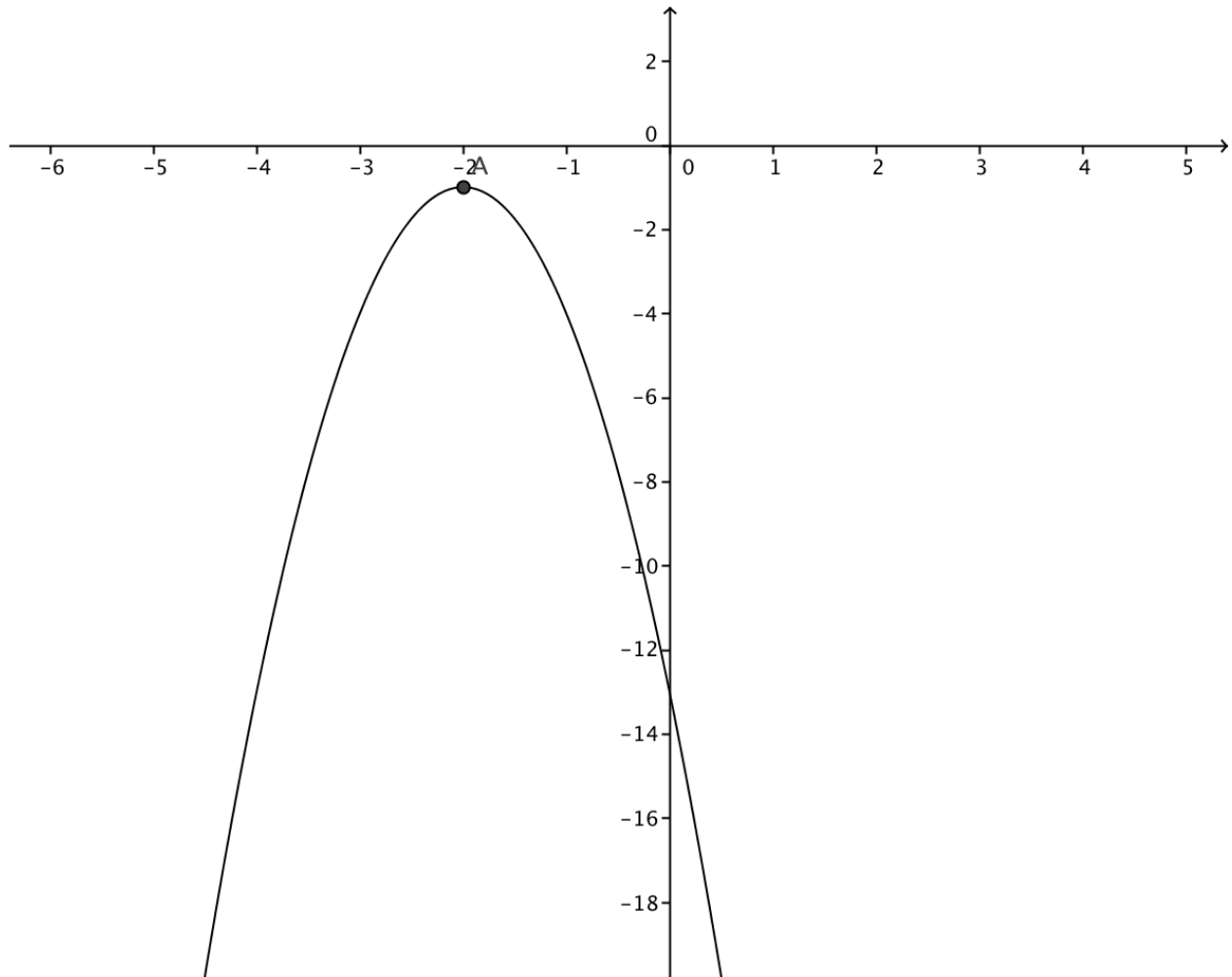

1. The vertex is $(-2, -1)$.
2. The axis of symmetry is $x = -2$.
3. The domain is all real numbers. The range is y is less than or equal to -1 .
4. The y -intercept is $(0, -13)$.
5. There are no x -intercepts.

2.

$$y = x^2 + 9x + 20$$

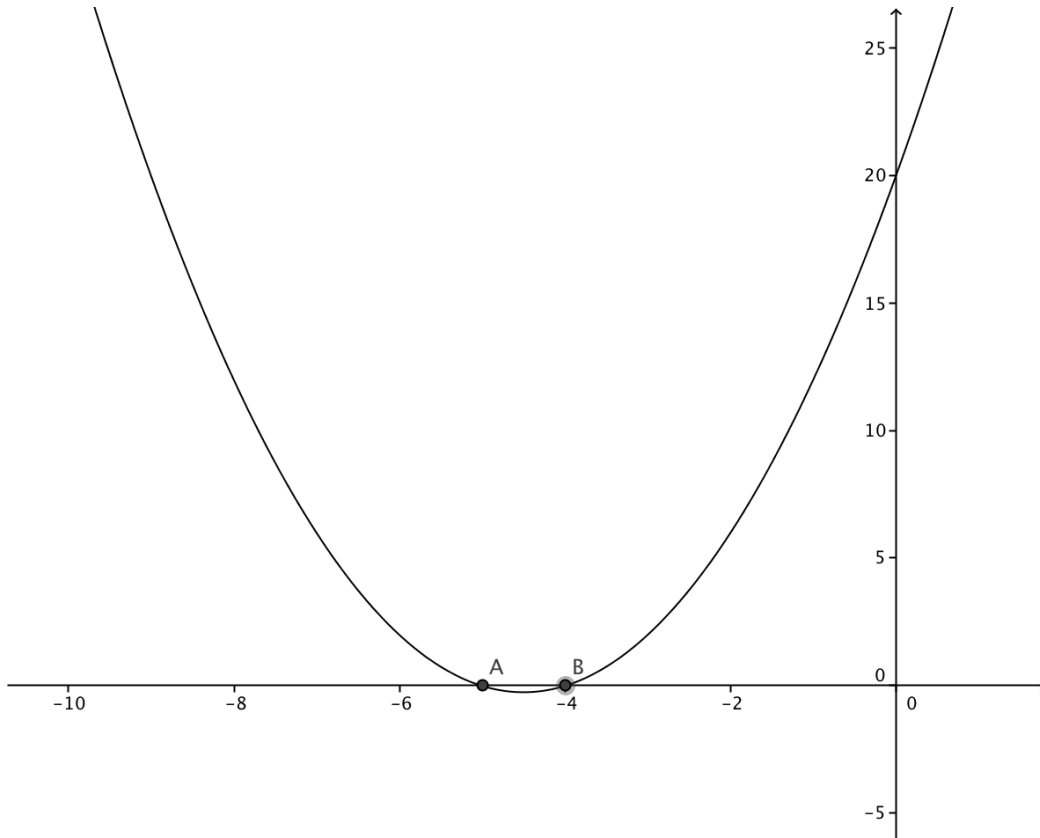

$$x = -4, -5$$

3.

$$74 = x^2 - 7$$

$$x^2 - 7 = 74$$

$$x^2 = 74 + 7$$

$$x^2 = 81$$

$$\sqrt{x^2} = \sqrt{81}$$

$$x = \pm 9$$

4.

$$h(t) = -\frac{1}{2}(g)t^2 + v_0t + h_0$$

$$h(t) = -\frac{1}{2}(32)t^2 + 100t + 5$$

$$h(t) = -16t^2 + 100t + 5$$

$$\text{vertex} = (h, k)$$

$$h = -\frac{b}{2a}$$

$$h(t) = -16t^2 + 100t + 5$$

$$b = 100$$

$$a = -16$$

$$h = -\frac{100}{2(-16)}$$

$$h = -\frac{100}{-32}$$

$$h = \frac{100}{32}$$

$$h = 3.125$$

$$h(t) = -16t^2 + 100t + 5$$

$$k = -16(3.125)^2 + 100(3.125) + 5$$

$$k = 161.25$$

1. vertex = (3.125, 161.25)

$$h(t) = -16t^2 + 100t + 5$$

$$0 = -16t^2 + 100t + 5$$

$$-5 = -16t^2 + 100t$$

$$-5 = -16\left(t^2 - \frac{100}{16}t\right)$$

$$-5 = -16\left(t^2 - \frac{25}{4}t\right)$$

$$-5 + \frac{625}{64}(-16) = -16\left(t^2 - \frac{25}{4}t + \frac{625}{64}\right)$$

$$-5 - \frac{10,000}{64} = -16\left(t - \frac{25}{8}\right)^2$$

$$-5 - \frac{625}{4} = -16\left(t - \frac{25}{8}\right)^2$$

$$-\frac{20}{4} - \frac{625}{4} = -16\left(t - \frac{25}{8}\right)^2$$

$$-\frac{645}{4} = -16\left(t - \frac{25}{8}\right)^2$$

$$-\frac{645}{4} = -16\left(t - \frac{25}{8}\right)^2$$

$$-\frac{645}{4} \div (-16) = \left(t - \frac{25}{8}\right)^2$$

$$\frac{645}{64} = \left(t - \frac{25}{8}\right)^2$$

$$\sqrt{\frac{645}{64}} = \sqrt{\left(t - \frac{25}{8}\right)^2}$$

$$\sqrt{\frac{645}{64}} = t - \frac{25}{8}$$

$$t = \frac{\sqrt{645}}{8} + \frac{25}{8}$$

2. $t \approx 6.2996$

$$h(t) = -16t^2 + 100t + 5$$

$$90 = -16t^2 + 100t + 5$$

$$85 = -16t^2 + 100t$$

$$85 = -16\left(t^2 - \frac{100}{16}t\right)$$

$$85 = -16\left(t^2 - \frac{25}{4}t\right)$$

$$85 + \frac{625}{64}(-16) = -16\left(t^2 - \frac{25}{4}t + \frac{625}{64}\right)$$

$$85 - \frac{10,000}{64} = -16\left(t - \frac{25}{8}\right)^2$$

$$85 - \frac{625}{4} = -16\left(t - \frac{25}{8}\right)^2$$

$$\frac{340}{4} - \frac{625}{4} = -16\left(t - \frac{25}{8}\right)^2$$

$$-\frac{285}{4} = -16\left(t - \frac{25}{8}\right)^2$$

$$-\frac{285}{4} \div (-16) = \left(t - \frac{25}{8}\right)^2$$

$$\frac{285}{64} = \left(t - \frac{25}{8}\right)^2$$

$$\sqrt{\frac{285}{64}} = \sqrt{\left(t - \frac{25}{8}\right)^2}$$

$$\sqrt{\frac{285}{64}} = t - \frac{25}{8}$$

$$t = \frac{\sqrt{285}}{8} + \frac{25}{8}$$

3. $t \approx 5.2352$

5.

$$v^2 - 20v + 25 = 6$$

$$v^2 - 20v = 6 - 25$$

$$v^2 - 20v = -19$$

$$v^2 - 20v + 100 = -19 + 100$$

$$(v - 10)^2 = 81$$

$$\sqrt{(v - 10)^2} = \sqrt{81}$$

$$v - 10 = \pm 9$$

$$v - 10 = 9$$

$$v = 19$$

$$v - 10 = -9$$

$$v = 1$$

$$v = 19, 1$$

Lesson 10.5

Solving Quadratic Equations Using the Quadratic Formula

1. The Quadratic Formula is a mathematical formula that can be used to solve a quadratic equation in standard form. Any quadratic equation can be solved using the quadratic formula, and it is the most common way to solve a quadratic equation. It is most useful when the equation is already in standard form. It is a good choice when graphing is too imprecise, when factoring is too difficult or complicated, or when square roots are not easily found.

2. The first known solution of a quadratic equation was recorded in 628 AD by an Indian mathematician named Brahmagupta.

3.

$$x^2 - 14x + 45 = 0$$

$$a = 1$$

$$b = -14$$

$$c = 45$$

$$x = -\frac{b}{a}$$

$$x = -\frac{(-14)}{1}$$

$$x = 14$$

4.

$$8x^2 - 16x - 42 = 0$$

$$a = 8$$

$$b = -16$$

$$c = -42$$

$$x = -\frac{b}{a}$$

$$x = -\frac{(-16)}{8}$$

$$x = 2$$

5.

$$4x^2 + 16x + 12 = 0$$

$$a = 4$$

$$b = 16$$

$$c = 12$$

$$x = -\frac{b}{a}$$

$$x = -\frac{(16)}{4}$$

$$x = -4$$

6.

$$x^2 + 2x - 15 = 0$$

$$a = 1$$

$$b = 2$$

$$c = -15$$

$$x = -\frac{b}{a}$$

$$x = -\frac{(2)}{1}$$

$$x = -2$$

7.

$$ax^2 + bx + c = 0$$

$$x = \frac{-b \pm \sqrt{b^2 - 4ac}}{2a}$$

$$x^2 + 4x - 21 = 0$$

$$x = \frac{-4 \pm \sqrt{(4^2) - 4(1)(-21)}}{2(1)}$$

$$x = \frac{-4 \pm \sqrt{16 + 84}}{2}$$

$$x = \frac{-4 \pm \sqrt{100}}{2}$$

$$x = \frac{-4 + \sqrt{100}}{2} = \frac{-4 + 10}{2} = \frac{6}{2} = 3$$

$$x = \frac{-4 - \sqrt{100}}{2} = \frac{-4 - 10}{2} = \frac{-14}{2} = -7$$

$$x = 3, -7$$

8.

$$ax^2 + bx + c = 0$$

$$x = \frac{-b \pm \sqrt{b^2 - 4ac}}{2a}$$

$$x^2 - 6x = 12$$

$$x^2 - 6x - 12 = 0$$

$$x = \frac{-(-6) \pm \sqrt{(-6)^2 - 4(1)(-12)}}{2(1)}$$

$$x = \frac{6 \pm \sqrt{36 + 48}}{2}$$

$$x = \frac{6 \pm \sqrt{84}}{2}$$

$$x = \frac{6 + \sqrt{84}}{2} \approx \frac{6 + 9.1652}{2} \approx \frac{15.1652}{2} \approx 5.0551$$

$$x = \frac{6 - \sqrt{84}}{2} \approx \frac{6 - 9.1652}{2} \approx \frac{-3.1652}{2} \approx -1.5826$$

$$x \approx 5.0551, -1.5826$$

9.

$$ax^2 + bx + c = 0$$

$$x = \frac{-b \pm \sqrt{b^2 - 4ac}}{2a}$$

$$3x^2 - \frac{1}{2}x = \frac{3}{8}$$

$$3x^2 - \frac{1}{2}x - \frac{3}{8} = 0$$

$$x = \frac{-(-\frac{1}{2}) \pm \sqrt{(-\frac{1}{2})^2 - 4(3)(-\frac{3}{8})}}{2(3)}$$

$$x = \frac{\frac{1}{2} \pm \sqrt{\frac{1}{4} + \frac{36}{8}}}{6}$$

$$x = \frac{0.5 \pm \sqrt{4.75}}{6}$$

$$x = \frac{0.5 + \sqrt{4.75}}{6} \approx \frac{0.5 + 2.1794}{6} = \frac{2.6794}{6} = 0.4466$$

$$x = \frac{0.5 - \sqrt{4.75}}{6} \approx \frac{0.5 - 2.1794}{6} = \frac{-1.6794}{6} = -0.2799$$

$$x = 0.4466, -0.2799$$

10.

$$ax^2 + bx + c = 0$$

$$x = \frac{-b \pm \sqrt{b^2 - 4ac}}{2a}$$

$$2x^2 + x - 3 = 0$$

$$x = \frac{-1 \pm \sqrt{(1)^2 - 4(2)(-3)}}{2(2)}$$

$$x = \frac{-1 \pm \sqrt{1 + 24}}{4}$$

$$x = \frac{-1 \pm \sqrt{25}}{4}$$

$$x = \frac{-1 + \sqrt{25}}{4} = \frac{-1 + 5}{4} = \frac{4}{4} = 1$$

$$x = \frac{-1 - \sqrt{25}}{4} = \frac{-1 - 5}{4} = \frac{-6}{4} = -1.5$$

$$x = 1, -1.5$$

11.

$$ax^2 + bx + c = 0$$

$$x = \frac{-b \pm \sqrt{b^2 - 4ac}}{2a}$$

$$-x^2 - 7x + 12 = 0$$

$$x = \frac{-(-7) \pm \sqrt{(-7)^2 - 4(-1)(12)}}{2(-1)}$$

$$x = \frac{7 \pm \sqrt{49 + 48}}{-2}$$

$$x = \frac{7 \pm \sqrt{97}}{-2}$$

$$x = \frac{7 + \sqrt{97}}{-2} \approx \frac{7 + 9.8489}{-2} \approx \frac{16.8489}{-2} \approx -8.4245$$

$$x = \frac{7 - \sqrt{97}}{-2} \approx \frac{7 - 9.8489}{-2} \approx \frac{-2.8489}{-2} \approx 1.4245$$

$$x = -8.4245, 1.4245$$

12.

$$ax^2 + bx + c = 0$$

$$x = \frac{-b \pm \sqrt{b^2 - 4ac}}{2a}$$

$$-3x^2 + 5x = 0$$

$$x = \frac{-(5) \pm \sqrt{(5)^2 - 4(-3)(0)}}{2(-3)}$$

$$x = \frac{-5 \pm \sqrt{25 + 0}}{-6}$$

$$x = \frac{-5 \pm \sqrt{25}}{-6}$$

$$x = \frac{-5 + \sqrt{25}}{-6} = \frac{-5 + 5}{-6} = \frac{0}{-6} = 0$$

$$x = \frac{-5 - \sqrt{25}}{-6} = \frac{-5 - 5}{-6} = \frac{-10}{-6} \approx 1.6667$$

$$x = 0, 1.6667$$

13.

$$ax^2 + bx + c = 0$$

$$x = \frac{-b \pm \sqrt{b^2 - 4ac}}{2a}$$

$$4x^2 = 0$$

$$x = \frac{-(0) \pm \sqrt{(0^2) - 4(4)(0)}}{2(4)}$$

$$x = \frac{0 \pm \sqrt{0+0}}{8}$$

$$x = \frac{0 \pm \sqrt{0}}{8}$$

$$x = \frac{0}{8} = 0$$

$$x = 0$$

14.

$$ax^2 + bx + c = 0$$

$$x = \frac{-b \pm \sqrt{b^2 - 4ac}}{2a}$$

$$x^2 + 6x + 2 = 0$$

$$x = \frac{-(6) \pm \sqrt{(6^2) - 4(1)(2)}}{2(1)}$$

$$x = \frac{-6 \pm \sqrt{36 - 8}}{2}$$

$$x = \frac{-6 \pm \sqrt{28}}{2}$$

$$x = \frac{-6 + \sqrt{28}}{2} \approx \frac{-6 + 5.2915}{2} \approx \frac{-0.7085}{2} \approx -0.3543$$

$$x = \frac{-6 - \sqrt{28}}{2} \approx \frac{-6 - 5.2915}{2} \approx \frac{-11.2915}{2} \approx -5.6458$$

$$x = -0.3543, -5.6458$$

For questions 15 through 26 the steps and process may differ according to the method chosen to solve the equation. The answers however, should always be the same. Listed are possible choices for the easiest method of solution.

15.

$$x^2 - x = 6$$

$$x^2 - x - 6 = 0$$

$$(x - 3)(x + 2) = 0$$

$$x - 3 = 0$$

$$x = 3$$

$$x + 2 = 0$$

$$x = -2$$

$$x = 3, -2$$

16.

$$x^2 - 12 = 0$$

$$x^2 = 12$$

$$\sqrt{x^2} = \sqrt{12}$$

$$x = \sqrt{12}$$

$$x \approx \pm 3.4641$$

17.

$$-2x^2 + 5x - 3 = 0$$

$$x = \frac{-b \pm \sqrt{b^2 - 4ac}}{2a}$$

$$x = \frac{-5 \pm \sqrt{5^2 - 4(-2)(-3)}}{2(-2)}$$

$$x = \frac{-5 \pm \sqrt{25 - 24}}{-4}$$

$$x = \frac{-5 \pm \sqrt{1}}{-4}$$

$$x = \frac{-5 + \sqrt{1}}{-4} = \frac{-5 + 1}{-4} = \frac{-4}{-4} = 1$$

$$x = \frac{-5 - \sqrt{1}}{-4} = \frac{-5 - 1}{-4} = \frac{-6}{-4} = 1.5$$

$$x = 1, 1.5$$

18.

$$x^2 + 7x - 18 = 0$$

$$x^2 + 7x = 18$$

$$x^2 + 7x + 12.25 = 18 + 12.25$$

$$(x + 3.5)^2 = 30.25$$

$$\sqrt{(x + 3.5)^2} = \sqrt{30.25}$$

$$x + 3.5 = \pm 5.5$$

$$x + 3.5 = 5.5$$

$$x = 2$$

$$x + 3.5 = -5.5$$

$$x = -9$$

$$x = 2, -9$$

19. $3x^2 + 6x = -10$

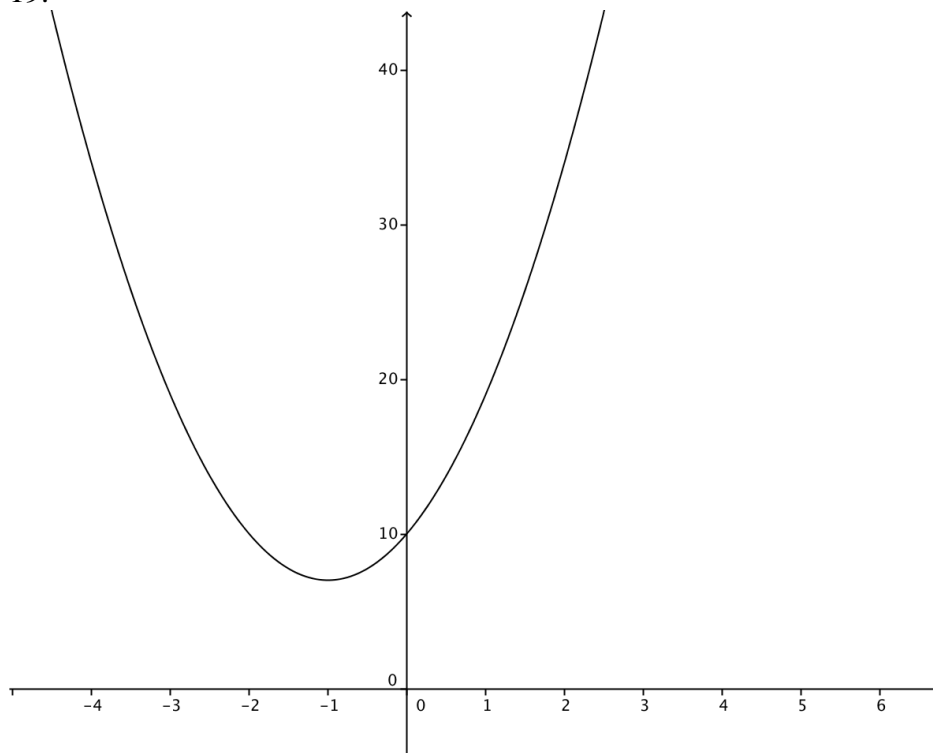

The graphs shows that the parabola does not intersect the x-axis, therefore there are no roots.

20.

$$-4x^2 + 400x = 0$$

$$-4(x^2 - 100x) = 0$$

$$-4(x^2 - 100x + 2500) = 0 + 2500(-4)$$

$$-4(x - 50)^2 = -10000$$

$$(x - 50)^2 = 2500$$

$$\sqrt{(x - 50)^2} = \sqrt{2500}$$

$$x - 50 = \pm 50$$

$$x - 50 = 50$$

$$x = 100$$

$$x - 50 = -50$$

$$x = 0$$

$$x = 100, 0$$

21.

$$-3x^2 + 12x + 1 = 0$$

$$-3x^2 + 12x = -1$$

$$-3(x^2 - 4x) = -1$$

$$-3(x^2 - 4x + 4) = -1 + 4(3)$$

$$-3(x - 2)^2 = -12$$

$$(x - 2)^2 = 4$$

$$\sqrt{(x - 2)^2} = \sqrt{4}$$

$$x - 2 = \pm 2$$

$$x - 2 = 2$$

$$x = 4$$

$$x - 2 = -2$$

$$x = 0$$

$$x = 4, 0$$

22.

$$x^2 + 6x + 9 = 0$$

$$(x + 3)(x + 3) = 0$$

$$(x + 3)^2 = 0$$

$$x + 3 = 0$$

$$x = -3$$

23.

$$81x^2 + 1 = 0$$

$$\sqrt{81x^2 + 1} = \sqrt{0}$$

$$(9x + 1) = 0$$

$$9x + 1 = 0$$

$$9x = -1$$

$$x = -\frac{1}{9}$$

24. $-4x^2 + 4x = 9$

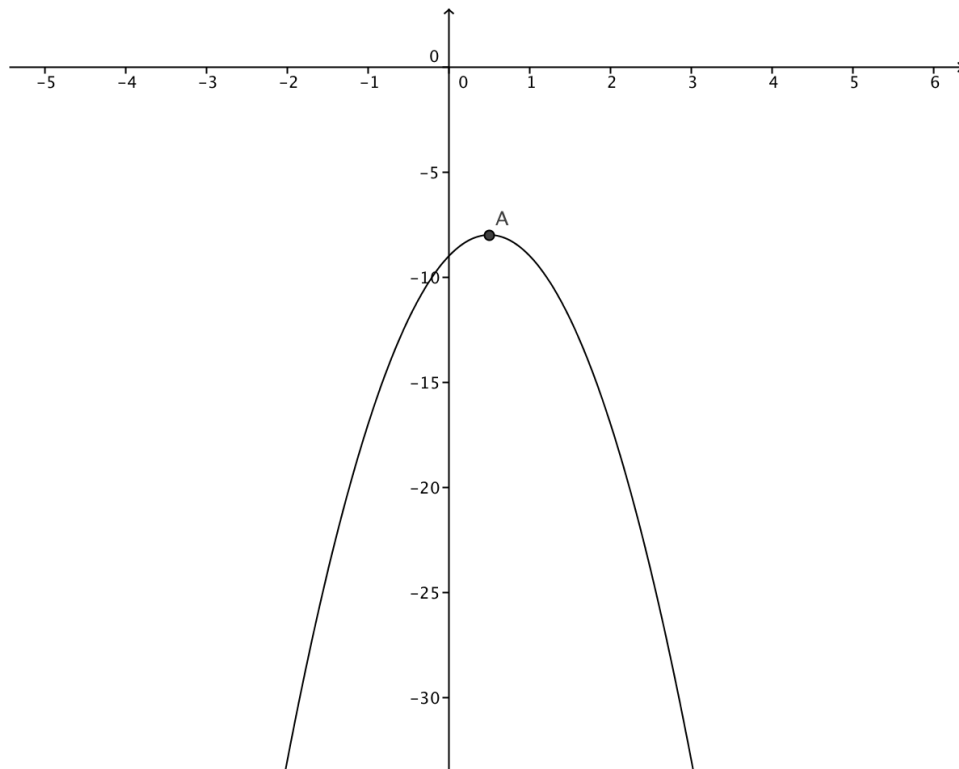

The graph shows that the parabola does not intersect the x-axis, therefore there are no roots.

25.

$$36x^2 - 21 = 0$$

$$\sqrt{36x^2 - 21} = \sqrt{0}$$

$$(6x - 4.5826) = 0$$

$$6x - 4.5826 = 0$$

$$6x = 4.5826$$

$$x \approx 0.7638$$

26.

$$x^2 + 2x - 3 = 0$$

$$(x + 3)(x - 1) = 0$$

$$x + 3 = 0$$

$$x = -3$$

$$x - 1 = 0$$

$$x = 1$$

$$x = -3, 1$$

27.

If we call one number x , then the second number is $x+1$. We know their product is 72, therefore:

$$x(x+1) = 72$$

$$x^2 + x = 72$$

$$\left(x^2 + x + \frac{1}{4}\right) = 72 + \frac{1}{4}$$

$$\left(x + \frac{1}{2}\right)^2 = \frac{289}{4}$$

$$\sqrt{\left(x + 0.5\right)^2} = \sqrt{72.25}$$

$$x + 0.5 = \pm 8.5$$

$$x + 0.5 = 8.5$$

$$x = 8$$

$$x + 0.5 = -8.5$$

$$x = -9$$

(There are two possibilities for x : 8 and -9. However -9 does not meet the requirements, because the next number consecutively is -10 and their product is not 72.)

The two consecutive integers are 8 and 9.

28.

If we call one number x , then the second number is $x+2$. Their product is $3(x+(x+2))-1$.

Therefore:

$$x(x+2) = 3(x+(x+2))-1$$

$$x^2 + 2x = 3(2x+2)-1$$

$$x^2 + 2x = 6x + 6 - 1$$

$$x^2 + 2x = 6x + 5$$

$$x^2 + 2x - 6x - 5 = 0$$

$$x^2 - 4x - 5 = 0$$

$$x^2 - 4x - 5 = 0$$

$$x^2 - 4x = 5$$

$$x^2 - 4x + 4 = 5 + 4$$

$$x^2 - 4x + 4 = 9$$

$$(x-2)^2 = 9$$

$$\sqrt{(x-2)^2} = \sqrt{9}$$

$$x-2 = 3$$

$$x = 3+2$$

$$x = 5$$

The two consecutive odd integers are 5 and 7.

29.

If we call the width x , then the length is $x+3$ and the rectangle looks like this:

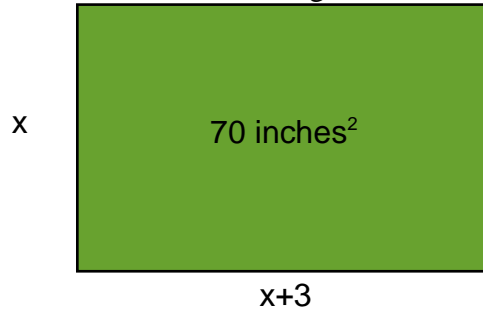

The Area of a rectangle is equal to its length times its width, therefore:

$$x(x+3) = 70$$

$$x^2 + 3x = 70$$

$$x^2 + 3x - 70 = 0$$

$$x = \frac{-b \pm \sqrt{b^2 - 4ac}}{2a}$$

$$x = \frac{-3 \pm \sqrt{3^2 - 4(1)(-70)}}{2(1)}$$

$$x = \frac{-3 \pm \sqrt{9 + 280}}{2}$$

$$x = \frac{-3 \pm \sqrt{289}}{2}$$

$$x = \frac{-3 + \sqrt{289}}{2} = \frac{-3 + 17}{2} = \frac{14}{2} = 7$$

$$x = \frac{-3 - \sqrt{289}}{2} = \frac{-3 - 17}{2} = \frac{-20}{2} = -10$$

$$x = 7, -10 \qquad \qquad \qquad l = 10$$

(There are two possible solutions for x , but since we are talking about distance the answer cannot be negative.)

The dimensions of the rectangle are 7inches by 10inches.

30.

The problem tells us that the width of the entire garden is x and the length of the entire garden is $2x$. It also tells us that the area of the entire garden is 200 sq ft. By using these pieces of information we can solve for x and then compute the amount of fence needed.

$$x(2x) = 200$$

$$2x^2 = 200$$

$$x^2 = 100$$

$$\sqrt{x^2} = \sqrt{100}$$

$$x = 10$$

Now we know that the width equals 10 ft and therefore the length equals 20 ft. We also know that the additional fencing needed to close off the three sections are also each equal to the width.

Now we add together all the pieces of fence.

$$x + x + x + x + 2x + 2x = y$$

$$4x + 4x = y$$

$$8x = y$$

$$8(10) = y$$

$$y = 80$$

Suzie will need 80 feet of fencing to enclose her entire garden and separate the sections.

31.

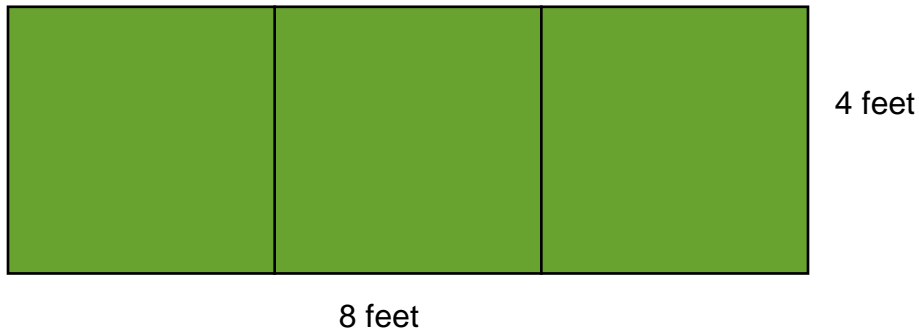

The rectangle above represents the larger board that Angel is cutting. It is divided into 3 equal squares. The area of the overall rectangle is $8 * 4 = 32$ sq feet. The cut off square is one third of this. The area of a square is side squared. Therefore:

$$\frac{1}{3} * 32 \approx 10.6667$$

$$x^2 \approx 10.6667$$

$$\sqrt{x^2} \approx \sqrt{10.6667}$$

$$x \approx 3.266$$

The length of the side of the square is approximately 3.266 feet.

32.

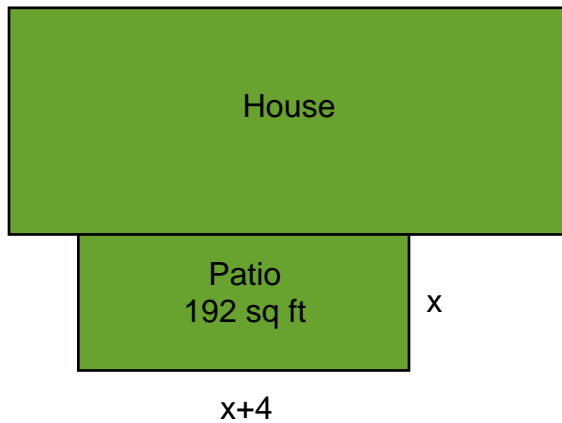

The diagram above shows what the house and patio would look like. We can call the width of the patio x and the length $x+4$. We know the total area of the patio is 192 sq ft, therefore:

$$x(x+4) = 192$$

$$x^2 + 4x = 192$$

$$x^2 + 4x - 192 = 0$$

$$x = \frac{-b \pm \sqrt{b^2 - 4ac}}{2a}$$

$$x = \frac{-4 \pm \sqrt{4^2 - 4(1)(-192)}}{2(1)}$$

$$x = \frac{-4 \pm \sqrt{16 + 768}}{2}$$

$$x = \frac{-4 \pm \sqrt{784}}{2}$$

$$x = \frac{-4 + \sqrt{784}}{2} = \frac{-4 + 28}{2} = \frac{24}{2} = 12$$

$$x = \frac{-4 - \sqrt{784}}{2} = \frac{-4 - 28}{2} = \frac{-32}{2} = -16$$

Because this is a distance problem, we only use the positive value of x , which is 12. If Mike is fencing in three sides then he needs:

$$x + x + x + 4 = y$$

$$3x + 4 = y$$

$$3(12) + 4 = y$$

$$36 + 4 = y$$

$$y = 40$$

Mike needs 40 feet of fencing to enclose the three sides of the patio.

Mixed Review

33.

Let's call the # of balcony seats x . This means the # of floor seats is $4x$. The number of box seats is $x+200$. We also know that the total number of seats is 1100, therefore:

$$x + 4x + (x + 200) = 1100$$

$$6x + 200 = 1100$$

$$6x = 900$$

$$x = 150$$

$$4x = 4(150) = 600$$

$$x + 200 = 150 + 200 = 350$$

The theatre has 150 balcony seats, 600 floor seats, and 350 box seats.

34.

$(10, 65)$ & $(5, 30)$

$$m = \frac{y_2 - y_1}{x_2 - x_1}$$

$$m = \frac{30 - 65}{5 - 10} = \frac{-35}{-5} = 7$$

$$y - 65 = 7(x - 10)$$

$$y - 65 = 7x - 70$$

$$y = 7x - 5$$

35.

$$120\%(x) = 60$$

$$1.2x = 60$$

$$x = 50$$

36.

$$\sqrt{16} = 4$$

4 is a Positive Real Number, an Integer, a Rational Number and a Natural or Whole Number.

37.

$$6\frac{1}{7} \div -2\frac{3}{4} = \frac{43}{7} \div -\frac{11}{4} = \frac{43}{7} \times -\frac{4}{11} = -\frac{172}{77} = -2\frac{18}{77}$$

38.

The most appropriate domain for a set of books in a library is whole numbers. It is not possible to have negative numbers of books, nor is it possible to have a fraction of a book, therefore the answer must be whole numbers.

Lesson 10.6

The Discriminant

1. The Discriminant is the value under the radical in the Quadratic Formula. It tells us how many real roots the quadratic equation has.

2. $D = b^2 - 4ac$

3. No you cannot find the discriminant of a linear equation. You need a quadratic equation in standard form to determine what the values of a, b, and c are. In a linear equation these values do not exist.

4.

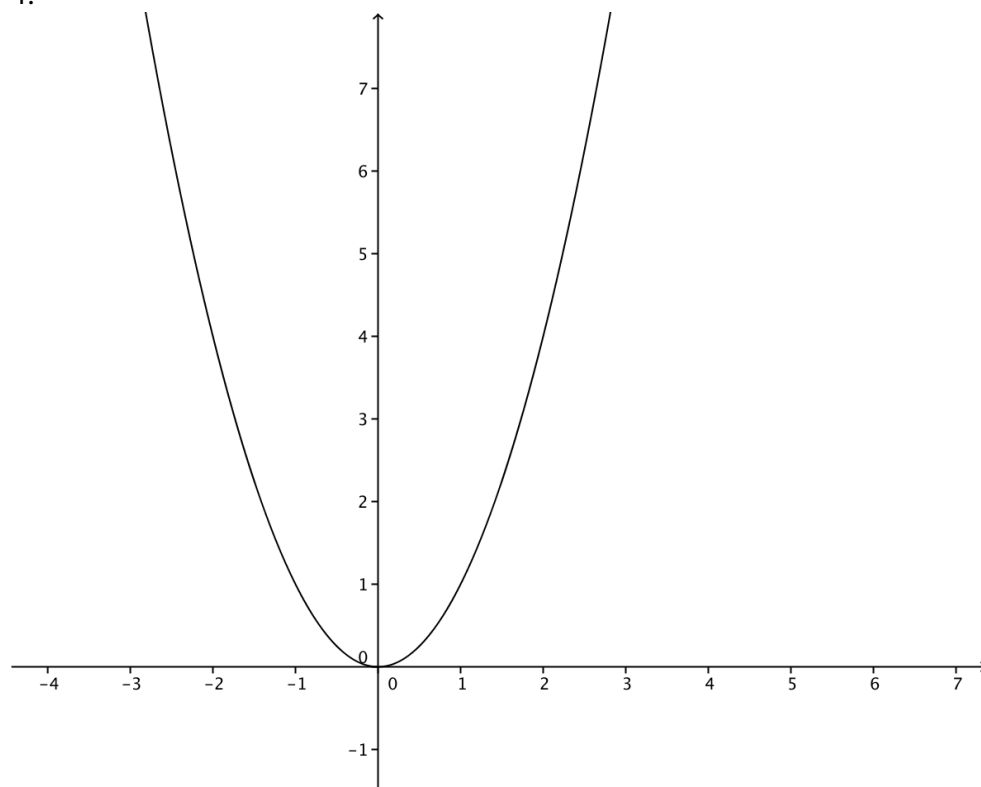

When $D=0$ there is one real solution.

5.

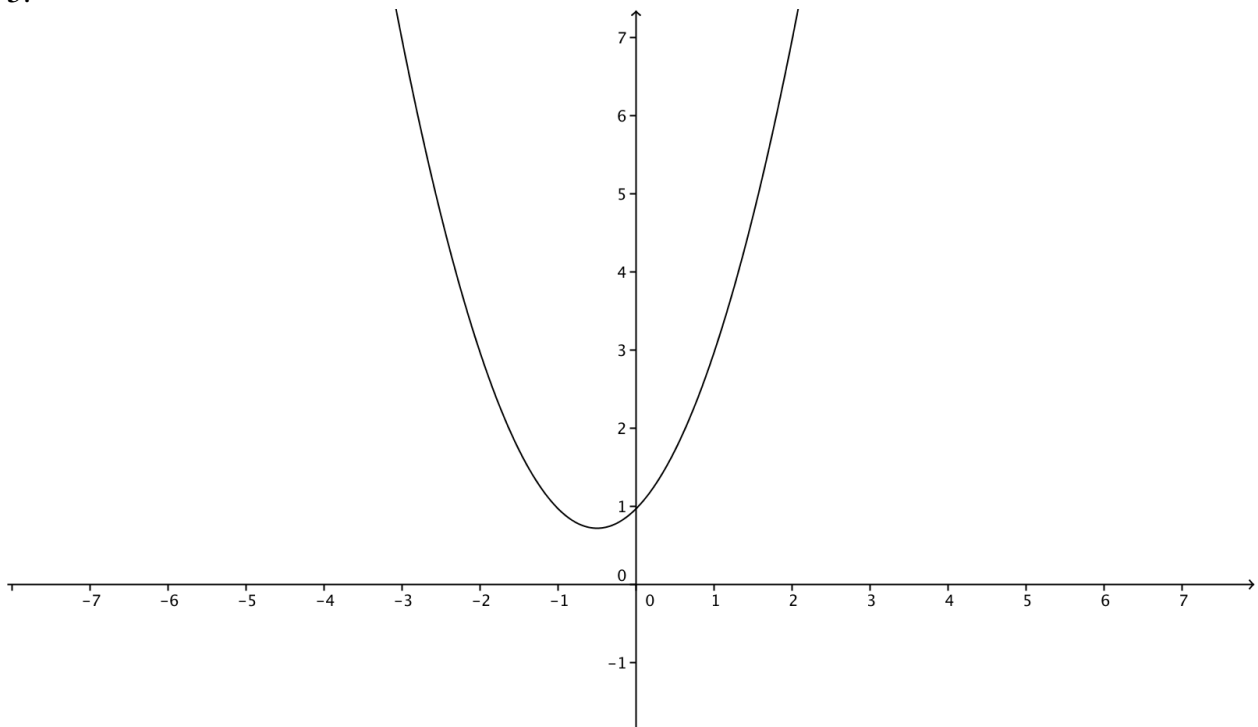

When $D = -2.85$ then the equation has no real solutions.

6.

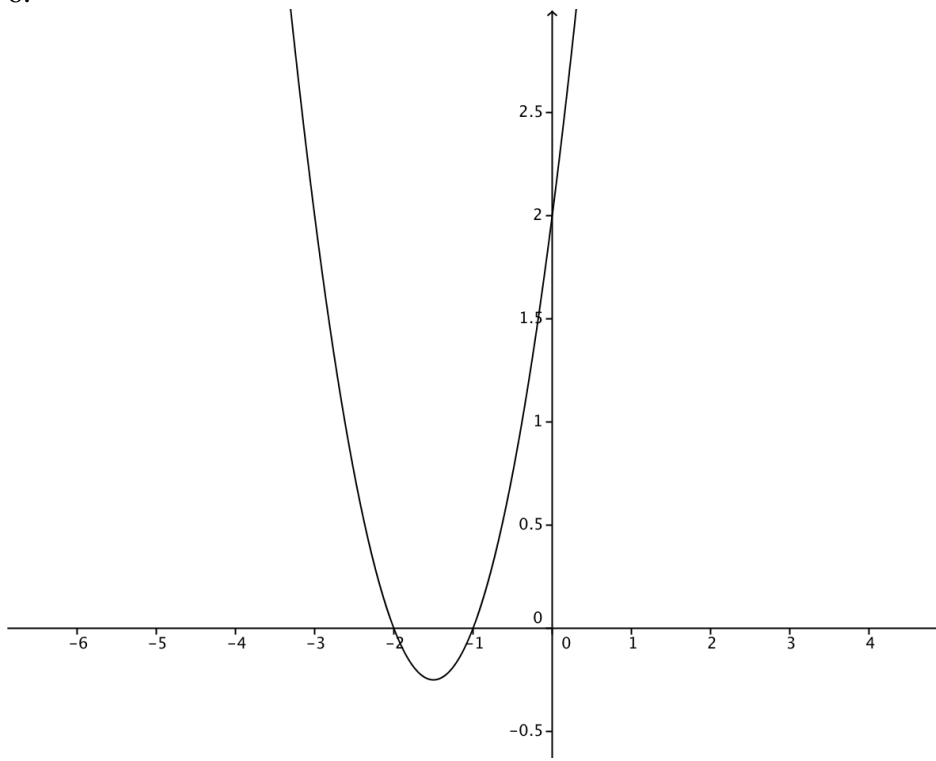

When $D > 0$ then there will be two real solutions.

7.

$$2x^2 - 4x + 5 = 0$$

$$D = b^2 - 4ac$$

$$D = (-4)^2 - 4(2)(5)$$

$$D = 16 - 40$$

$$D = -24$$

8.

$$x^2 - 5x = 8$$

$$x^2 - 5x - 8 = 0$$

$$D = b^2 - 4ac$$

$$D = (-5)^2 - 4(1)(-8)$$

$$D = 25 + 32$$

$$D = 57$$

9.

$$4x^2 - 12x + 9 = 0$$

$$D = b^2 - 4ac$$

$$D = (-12)^2 - 4(4)(9)$$

$$D = 144 - 144$$

$$D = 0$$

10.

$$x^2 + 3x + 2 = 0$$

$$D = b^2 - 4ac$$

$$D = (3)^2 - 4(1)(2)$$

$$D = 9 - 8$$

$$D = 1$$

11.

$$x^2 - 16x = 32$$

$$x^2 - 16x - 32 = 0$$

$$D = b^2 - 4ac$$

$$D = (-16)^2 - 4(1)(32)$$

$$D = 256 - 128$$

$$D = 128$$

12.

$$-5x^2 + 5x - 6 = 0$$

$$D = b^2 - 4ac$$

$$D = (5)^2 - 4(-5)(-6)$$

$$D = 25 - 120$$

$$D = -95$$

13.

$$-x^2 + 3x - 6 = 0$$

$$D = b^2 - 4ac$$

$$D = (3)^2 - 4(-1)(-6)$$

$$D = 9 - 24$$

$$D = -15$$

This quadratic equation will have no real solutions.

14.

$$5x^2 = 6x$$

$$5x - 6x = 0$$

$$D = b^2 - 4ac$$

$$D = (-6)^2 - 4(5)(0)$$

$$D = 36 - 0$$

$$D = 36$$

This quadratic equation will have two real solutions.

15.

$$41x^2 - 31x - 52 = 0$$

$$D = b^2 - 4ac$$

$$D = (-31)^2 - 4(41)(-52)$$

$$D = 961 + 8528$$

$$D = 9489$$

This quadratic equation will have two real solutions.

16.

$$x^2 - 8x + 16 = 0$$

$$D = b^2 - 4ac$$

$$D = (-8)^2 - 4(1)(16)$$

$$D = 64 - 64$$

$$D = 0$$

This quadratic equation will have one real solution.

17.

$$-x^2 + 3x - 10 = 0$$

$$D = b^2 - 4ac$$

$$D = (3)^2 - 4(-1)(10)$$

$$D = 9 - 40$$

$$D = -31$$

This quadratic equation will have no real solutions.

18.

$$x^2 - 64 = 0$$

$$D = b^2 - 4ac$$

$$D = (0)^2 - 4(1)(-64)$$

$$D = 0 + 256$$

$$D = 256$$

This quadratic equation will have two real solutions.

19.

$$x^2 = -4x + 20$$

$$x^2 + 4x - 20 = 0$$

$$D = b^2 - 4ac$$

$$D = (4)^2 - 4(1)(-20)$$

$$D = 16 + 80$$

$$D = 96$$

The Discriminant is NOT a perfect square, so the solutions will be irrational numbers.

20.

$$x^2 + 2x - 3 = 0$$

$$D = b^2 - 4ac$$

$$D = (2)^2 - 4(1)(-3)$$

$$D = 4 + 12$$

$$D = 16$$

The Discriminant IS a perfect square, so the solutions will be rational numbers.

21.

$$3x^2 - 11x = 10$$

$$3x^2 - 11x - 10 = 0$$

$$D = b^2 - 4ac$$

$$D = (-11)^2 - 4(3)(-10)$$

$$D = 121 + 120$$

$$D = 241$$

The Discriminant is NOT a perfect square, so the solutions will be irrational numbers.

22.

$$\frac{1}{2}x^2 + 2x + \frac{2}{3} = 0$$

$$D = b^2 - 4ac$$

$$D = (2)^2 - 4\left(\frac{1}{2}\right)\left(\frac{2}{3}\right)$$

$$D = 4 - \frac{4}{3}$$

$$D = \frac{8}{3}$$

The Discriminant is NOT a perfect square, so the solutions will be irrational numbers.

23.

$$x^2 - 10x + 25 = 0$$

$$D = b^2 - 4ac$$

$$D = (-10)^2 - 4(1)(25)$$

$$D = 100 - 100$$

$$D = 0$$

The Discriminant equals 0, so the solution will be a rational number.

24.

$$x^2 = 5x$$

$$x^2 - 5x = 0$$

$$D = b^2 - 4ac$$

$$D = (-5)^2 - 4(1)(0)$$

$$D = 25 - 0$$

$$D = 25$$

The Discriminant IS a perfect square, so the solutions will be rational.

25.

$$h(t) = -32t^2 + 55t + 4$$

$$36 = -32t^2 + 55t + 4$$

$$0 = -32t^2 + 55t + 4 - 36$$

$$0 = -32t^2 + 55t - 32$$

$$D = b^2 - 4ac$$

$$D = (55)^2 - 4(-32)(-32)$$

$$D = 3025 - 4096$$

$$D = -1071$$

The Discriminant is a negative number so the equation has no real solutions. Therefore: when Marty throws the phone it will not reach Yolanda.

26.

$$R = x(200 - 0.4x)$$

$$R = 200x - 0.4x^2$$

$$-0.4x^2 - 200x = R$$

$$-0.4x^2 - 200x = 20,000$$

$$-0.4x^2 - 200x - 20,000 = 0$$

$$D = b^2 - 4ac$$

$$D = (-200)^2 - 4(-0.4)(-20,000)$$

$$D = 40,000 - 32,000$$

$$D = 8,000$$

The Discriminant of the equation is a positive number so there are two real solutions.

Yes, there are two possible ways in which Bryson's business can generate a revenue of \$20,000 in the month of July.

27.

$$y = -\frac{32}{6400}x^2 + x$$

$$10 = -\frac{32}{6400}x^2 + x$$

$$0 = -\frac{32}{6400}x^2 + x - 10$$

$$D = b^2 - 4ac$$

$$D = (1)^2 - 4\left(-\frac{32}{6400}\right)(-10)$$

$$D = 1 - \frac{1}{5}$$

$$D = \frac{4}{5}$$

The Discriminant of the equation is a positive number so there are two real solutions.

Yes, Marcus kicked the ball hard enough to go over the goal post.

Mixed Review

28.

$$6x^2 - x - 12$$

$$(3x + 4)(2x - 3)$$

29.

$$y = a(x - h)^2 + k$$

$$y = -\frac{1}{4}x^2 - 3x - 12$$

$$12 = -\frac{1}{4}x^2 - 3x$$

$$12 = -\frac{1}{4}(x^2 + 12x)$$

$$12 + 36\left(-\frac{1}{4}\right) = -\frac{1}{4}(x^2 + 12x + 36)$$

$$12 - 9 = -\frac{1}{4}(x + 6)^2$$

$$3 = -\frac{1}{4}(x + 6)^2$$

$$0 = -\frac{1}{4}(x + 6)^2 - 3$$

$$y = -\frac{1}{4}(x + 6)^2 - 3$$

$$\text{vertex} = (-6, -3)$$

30.

$$-4x^2 - 15 = -4x$$

$$-4x^2 - 15 + 4x = 0$$

$$-4x^2 + 4x - 15 = 0$$

$$x = \frac{-b \pm \sqrt{b^2 - 4ac}}{2a}$$

$$x = \frac{-4 \pm \sqrt{4^2 - 4(-4)(-15)}}{2(-4)}$$

$$x = \frac{-4 \pm \sqrt{16 - 240}}{-8}$$

$$x = \frac{-4 \pm \sqrt{-224}}{-8}$$

The quadratic equation has no real solutions.

31.

$$1 \text{ fathom} = 6 \text{ feet}$$

$$4 \text{ fathoms} = 6 * 4 = 24 \text{ feet}$$

$$1 \text{ foot} = 30.48 \text{ cm}$$

$$24 \text{ ft} = 30.48 * 24 = 731.52 \text{ cm}$$

$$4 \text{ fathoms} = 731.52 \text{ cm}$$

32.
$$\begin{cases} 3x + 2y \leq -4 \\ x - y > -3 \end{cases}$$

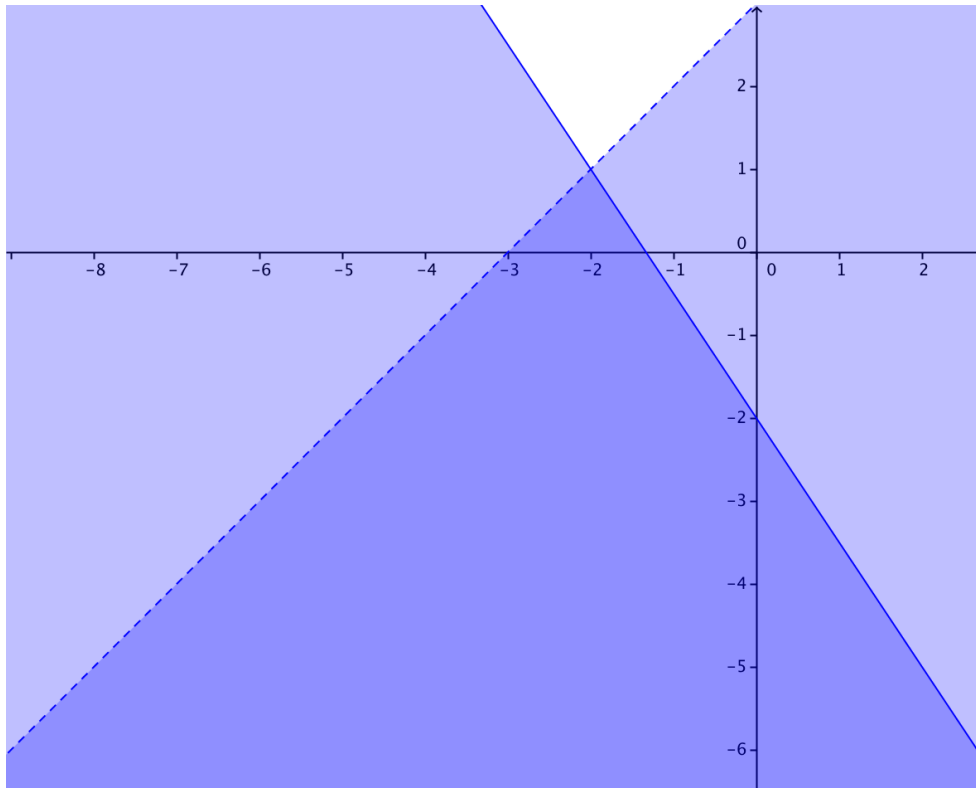

33.

Assuming that the order does not matter, and that you CAN repeat toppings:

$$7 * 7 * 7 = 343 \text{ ways.}$$

Assuming that the order does not matter and that you CANNOT repeat toppings:

$${}_7C_3 = 35$$

Lesson 10.7

Linear, Exponential, and Quadratic Models

1. If the second set of differences have the same value it can be concluded that the equation is a quadratic.
2. If you have to find the difference 5 times you can safely assume that the degree of the polynomial is 5. It is an equation with a degree of 5.
3. You would test the ratio of differences to determine if the equation is exponential.
4. If you have a cubic function you can conclude that you would have to take the differences 3 times.
5. The first difference is always 3, therefore the data can be modeled by a linear function.
6. Neither the first or second differences are equal so the equation is neither linear nor quadratic.
7. The first difference is always 25, therefore the data can be modeled by a linear function.
8. The second difference is always 5, therefore the data can be modeled by a quadratic function.
9. The second difference is always 2, therefore the data can be modeled by a quadratic function.
10. Neither the first or second differences are equal so the equation is neither linear nor quadratic.
11. This data CANNOT be modeled by an exponential function because the ratios are not equal.
12. This data CAN be modeled by an exponential function because the ratios are equal.
13. This data CAN be modeled by an exponential function because the ratios are equal.

14.

$$500/400=1.25$$

$$625/500=1.25$$

$$781.25/625=1.25$$

$$876.5625/781.25=1.25$$

Because the ratios are equal, this is an exponential function.

$$y = a(b)^x$$

$$a = 400$$

$$b = 1.25$$

$$y = 400(1.25)^x$$

15.

$$(-3)-(-2)=-1$$

$$(-2)-(-1)=-1$$

$$(-1)-0=-1$$

$$0-1=-1$$

$$1-2=-1$$

Because the first set of differences are equal, this is a linear function.

$$y = mx + b$$

$$m = 0.5$$

$$b = 1.5$$

$$y = 0.5x + 1.5$$

16.

$$14-4=10$$

$$4-(-2)=6$$

$$(-2)-(-4)=2$$

$$(-4)-(-2)=-2$$

$$(-2)-4=-6$$

$$4-14=-10$$

$$10-6=4$$

$$6-2=4$$

$$2-(-2)=4$$

$$(-2)-(-6)=4$$

$$(-6)-(-10)=4$$

Because the second set of differences are equal, this is a quadratic function.

$$y = ax^2 + bx + c$$

$$a = 2$$

$$b = 0$$

$$c = -4$$

$$y = 2x^2 - 4$$

17.

1. & 3.

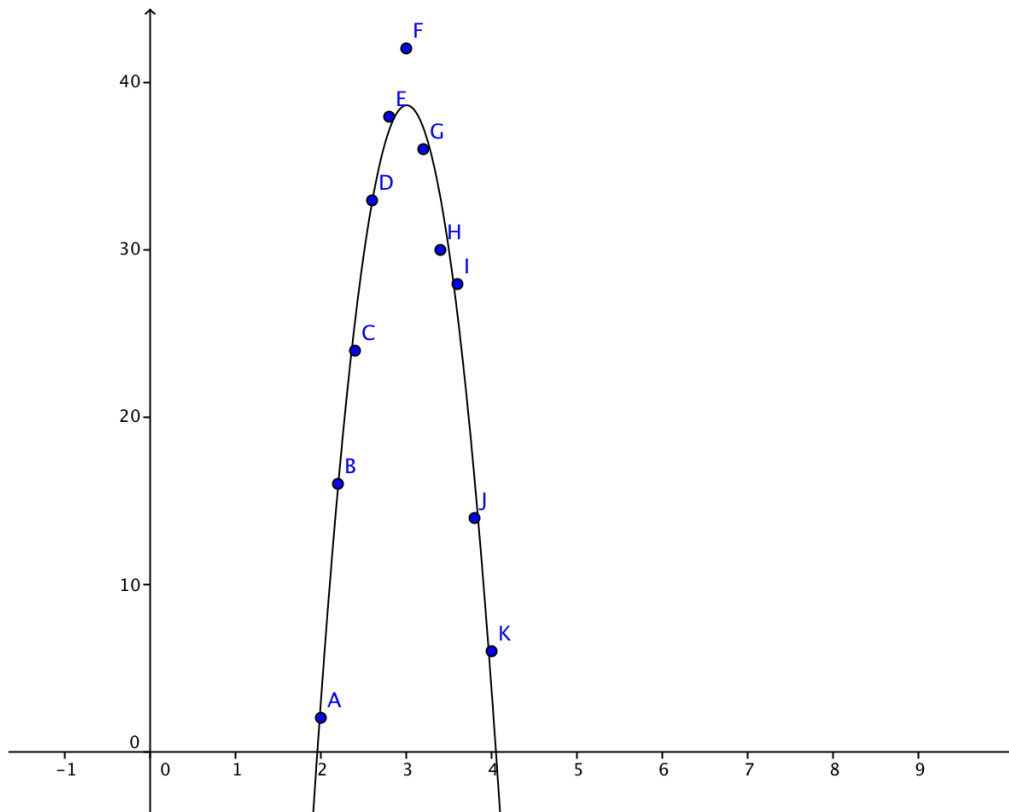

2. $y = -35.43x^2 + 213.31x - 282.44$

4. The maximum height is 42.

$$y = -35.43x^2 + 213.31x - 282.44$$

$$y = -35.43(2.5)^2 + 213.31(2.5) - 282.44$$

$$y = -221.4375 + 533.275 - 282.44$$

5. $y = 29.3975$

At 2.5 seconds the ball will be at approximately 29.3975.

18.

1.

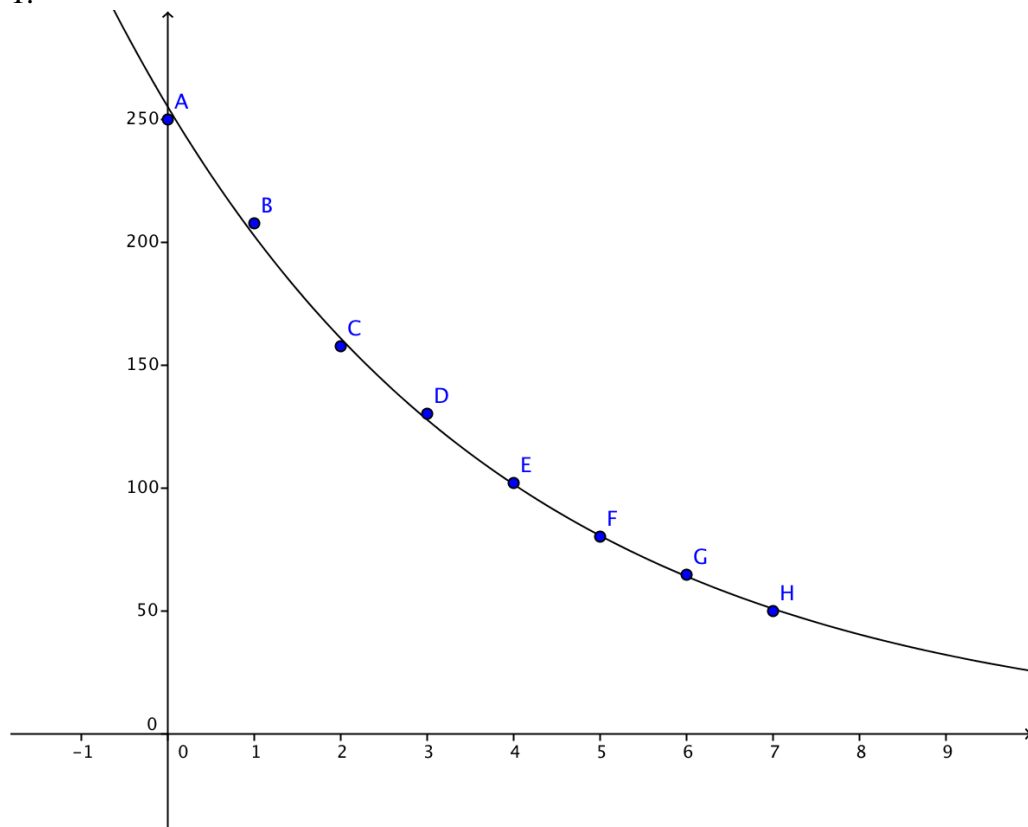

2. An exponential function best suits the data.

$$y = a(b)^x$$

$$a = 255.25$$

$$b = 0.79$$

3. $y = 255.25(0.79)^x$

$$y = 255.25(0.79)^x$$

$$y = 255.25(0.79)^{10}$$

4. $y = 24.1678$

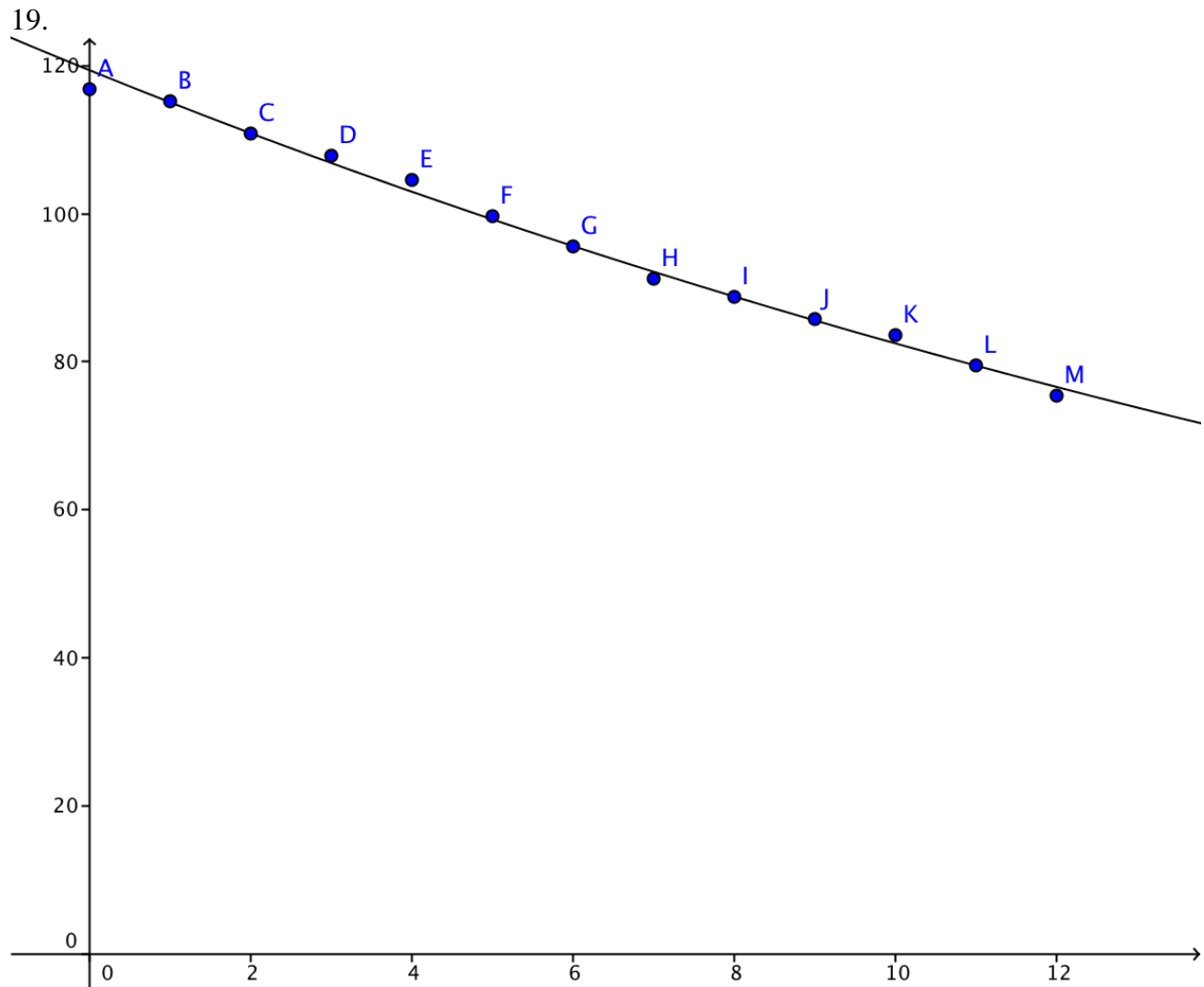

$$y = a(b)^x$$

$$a = 119.41$$

$$b = 0.96$$

$$y = 119.41(0.96)^x$$

The model that best fits the data is the exponential function $y = 119.41(0.96)^x$

$$y = 119.41(0.96)^x$$

$$y = 119.41(0.96)^{20}$$

$$y = 52.7795$$

Based on this model the rate of pregnancy in 2010 will be 52.7795

Mixed Review

20.

$$y = mx + b$$

$$y = 2.5x$$

$$16 = 2.5x$$

$$x = 6.4$$

The equation for this scenario is $y=2.5x$.

Cam will run out of flour after 6.4 loaves of bread.

21.

$$h(t) = -\frac{1}{2}(g)t^2 + v_0t + h_0$$

$$h(t) = -\frac{1}{2}(32)t^2 + 10t + 7$$

1. $h(t) = -16t^2 + 10t + 7$

$$h(t) = -16t^2 + 10t + 7$$

$$0 = -16t^2 + 10t + 7$$

$$-7 = -16t^2 + 10t$$

$$-7 = -16\left(t^2 - \frac{10}{16}t\right)$$

$$-7 + \frac{100}{1024}(-16) = -16\left(t^2 - \frac{10}{16}t + \frac{100}{1024}\right)$$

$$-7 - \frac{100}{64} = -16\left(t - \frac{10}{32}\right)^2$$

$$-8.5625 = -16(t - 0.3125)^2$$

$$y = -16(t - 0.3125)^2 + 8.5625$$

2. $(h, k) = (0.3125, 8.5625)$

The maximum height the ball reaches is 8.5625 ft.

3. The y-intercept is (0,7). It represents the initial height the basketball is being shot from.

$$\begin{aligned}
h(t) &= -16t^2 + 10t + 7 \\
0 &= -16t^2 + 10t + 7 \\
-7 &= -16t^2 + 10t \\
-7 &= -16\left(t^2 - \frac{10}{16}t\right) \\
-7 + \frac{100}{1024}(-16) &= -16\left(t^2 - \frac{10}{16}t + \frac{100}{1024}\right) \\
-7 - \frac{100}{64} &= -16\left(t - \frac{10}{32}\right)^2 \\
-8.5625 &= -16(t - 0.3125)^2 \\
0.5352 &= (t - 0.3125)^2 \\
\sqrt{0.5352} &= \sqrt{(t - 0.3125)^2} \\
0.7316 &= t - 0.3125
\end{aligned}$$

4. $t \approx 1.0441$

The ball will hit the ground at approximately 1.044 seconds.

$$\begin{aligned}
h(t) &= -16t^2 + 10t + 7 \\
11 &= -16t^2 + 10t + 7 \\
0 &= -16t^2 + 10t + 7 - 11 \\
0 &= -16t^2 + 10t - 4 \\
a &= -16 \\
b &= 10 \\
c &= -4 \\
D &= b^2 - 4ac \\
D &= 10^2 - 4(-16)(-4) \\
D &= 100 - 256
\end{aligned}$$

5. $D = -156$

The ball will NOT reach 11 feet because the discriminant is a negative number, meaning that this equation has no solutions.

22.

$$y = |x - 2| + 3$$

x	$ x-2 +3$	y
3	$ 3-2 +3=1+3=4$	4
2	$ 2-2 +3=0+3=3$	3
1	$ 1-2 +3=1+3=4$	4
0	$ 0-2 +3=2+3=5$	5
-1	$ -1-2 +3=3+3=6$	6
-2	$ -2-2 +3=4+3=7$	7
-3	$ -3-2 +3=5+3=8$	8

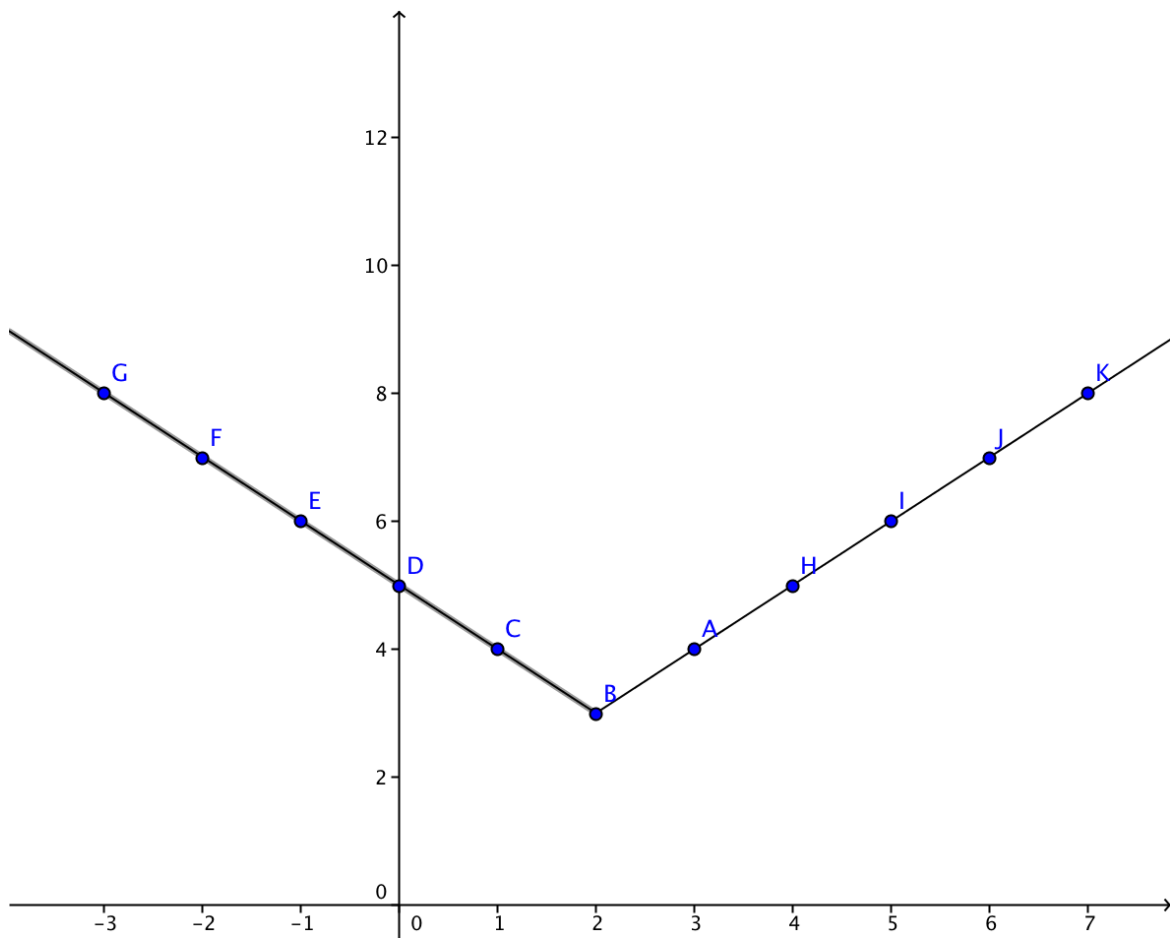

Domain= all Real numbers

Range= all Real numbers >3

23.

$$6 \geq -5(c + 4) + 10$$

$$6 \geq -5c - 20 + 10$$

$$6 \geq -5c - 10$$

$$6 + 10 \geq -5c$$

$$16 \geq -5c$$

$$-3.2 \geq c$$

$$c \leq -3.2$$

24.

Yes this relation is a function. Its domain is $2 \geq x \geq -6$. Its range is $5 \geq y \geq -3$.

25.

Graphing Quadratic Equations: by graphing a quadratic function we can determine the vertex, x-intercepts (solutions, roots) and y-intercept

Solving Quadratic Equations Using Square Roots: when a function is in the form $0 = ax^2 - c$ then you can solve by taking moving the c to the other side of the equation and taking the square roots of both sides

Completing the Square: any quadratic equation can be solved by completing the square. You must create a perfect square trinomial which looks like $a^2 + 2ab + b^2 = (a + b)^2$. You do this by eliminating any leading coefficient through division so that $a = x$ and then dividing b by 1/2 and adding the square of b to the entire equation. (Remember whatever you do to one side of the equation you have to do to the other side.)

Solving Using the Quadratic Formula: for any quadratic equation in standard form, $y = ax^2 + bx + c$, you solve by plugging a, b, and c into the quadratic formula.

$$y = \frac{-b \pm \sqrt{b^2 - 4ac}}{2a}$$

Using the Discriminant: the Discriminant (D) is the value under the radical sign in the quadratic formula ($D = b^2 - 4ac$) If D is negative, then your function has no solutions. If D is 0 then your function has only one solution. If D is positive, then your function has 2 solutions. If D is a perfect square, then your solutions will be rational. If D is not a perfect square, then your solutions will be irrational.

Lesson 10.8

Problem Solving Strategies: Choose a Function Model

1.

1. An exponential function seems to be the best model for this situation.

2.

$$y = mx + b$$

$$m \approx -2.736$$

$$b \approx 43.3989$$

$$y = -2.736x + 43.3989$$

$$y = -2.736x + 43.3989$$

$$y = -2.736(4.2) + 43.3989$$

$$y = 31.9077$$

3.

$$y = ax^2 + bx + c$$

$$a \approx 0.0748$$

$$b \approx -3.8682$$

$$c \approx 49.9791$$

$$y = 0.0748x^2 - 3.8682x + 49.9791$$

$$y = 0.0748x^2 - 3.8682x + 49.9791$$

$$y = 0.0748(4.2)^2 - 3.8682(4.2) + 49.9791$$

$$y = 35.0522$$

4.

$$y = ax^3 + bx^2 + cx + d$$

$$a \approx -4.6 \times 10^{-14}$$

$$b \approx 0.0748$$

$$c \approx -3.8682$$

$$d \approx 49.9791$$

$$y = (-4.6 \times 10^{-14})x^3 + 0.0748x^2 - 3.8682x + 49.9791$$

$$y = (-4.6 \times 10^{-14})x^3 + 0.0748x^2 - 3.8682x + 49.9791$$

$$y = (-4.6 \times 10^{-14})(4.2)^3 + 0.0748(4.2)^2 - 3.8682(4.2) + 49.9791$$

$$y = 35.0522$$

5. The quadratic or cubic regressions seem to be the models that best fit.

6.

$$y = 0.0748x^2 - 3.8682x + 49.9791$$

$$y = 0.0748(5)^2 - 3.8682(5) + 49.9791$$

$$y = 32.5081$$

The height of the water at 5 seconds is about 32.5081 cm.

7.

$$y = 0.0748x^2 - 3.8682x + 49.9791$$

$$y = 0.0748(13)^2 - 3.8682(13) + 49.9791$$

$$y = 12.3337$$

The height of the water at 13 seconds is about 12.3337 cm.

2.

1. Of the three options, quadratic seems the best fit.

$$2. y = -0.4264x^3 + 18.9454x^2 - 127.2956x + 80.2576$$

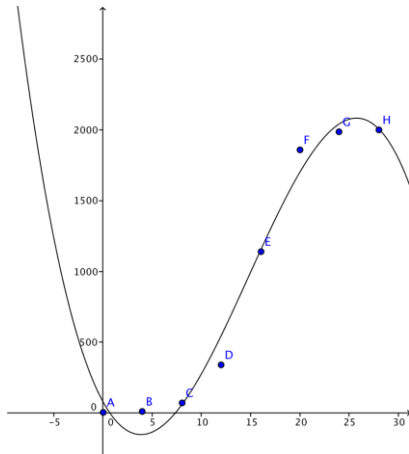

$$3. n(g) = -0.4264g^3 + 18.9454g^2 - 127.2956g + 80.2576$$

4.

$$n(g) = -0.4264g^3 + 18.9454g^2 - 127.2956g + 80.2576$$

$$n(10) = -0.4264(10^3) + 18.9454(10^2) - 127.2956(10) + 80.2576$$

$$n(10) = -0.4264(1000) + 18.9454(100) - 1272.956 + 80.2576$$

$$n(10) = -426.4 + 1894.54 - 1272.956 + 80.2576$$

$$n(10) = 275.4416$$

5.

$$n(g) = -0.4264g^3 + 18.9454g^2 - 127.2956g + 80.2576$$

$$n(25) = -0.4264(25^3) + 18.9454(25^2) - 127.2956(25) + 80.2576$$

$$n(25) = -0.4264(15625) + 18.9454(625) - 3182.39 + 80.2576$$

$$n(25) = -6662.5 + 11840.875 - 3182.39 + 80.2576$$

$$n(25) = 2076.2426$$

3.

$$y = -4.92x^2 + 34.7x + 1.2$$

$$0 = -4.92x^2 + 34.7x + 1.2$$

$$-1.2 = -4.92x^2 + 34.7x$$

$$-1.2 = -4.92(x^2 - 7.0528x)$$

$$-1.2 + 12.4355(-4.92) = -4.92(x^2 - 7.0528x + 12.4355)$$

$$-1.2 - 61.1827 = -4.92(x - 3.5264)^2$$

$$-62.3827 = -4.92(x - 3.5264)^2$$

$$0 = -4.92(x - 3.5264)^2 + 62.3827$$

$$y = a(x - h)^2 + k$$

$$y = -4.92(x - 3.5264)^2 + 62.3827$$

$$(h, k) = (3.5264, 62.3827)$$

The maximum height of the golf ball is approximately 62.3827 meters.

4.

$$y = -4.92x^2 + 34.7x + 1.2$$

$$x = 5.2$$

$$y = -4.92(5.2)^2 + 34.7(5.2) + 1.2$$

$$y = -4.92(27.04) + 180.44 + 1.2$$

$$y = -133.0368 + 180.44 + 1.2$$

$$y = 48.6032$$

At 5.2 seconds the height of the golf ball will be approximately 48.6032 meters.

Mixed Review

5.

$$2 \div 6 * 5 + 3^2 - 11 * 9 \frac{1}{2}$$

$$2 \div 6 * 5 + 9 - 11 * 9 \frac{1}{2}$$

$$(2 \div 6) * 5 + -11 * 9 \frac{1}{2}$$

$$\left(\frac{2}{6} * 5\right) + -11 * 9 \frac{1}{2}$$

$$\frac{10}{6} + (-11 * 9 \frac{1}{2})$$

$$\frac{10}{6} + \frac{209}{2} = \frac{10}{6} + \frac{627}{6} = \frac{637}{6} = 106 \frac{1}{6}$$

6.

(60,812)(115,1126)

$$m = \frac{y_2 - y_1}{x_2 - x_1}$$

$$m = \frac{1126 - 812}{115 - 60} = \frac{314}{55} \approx 5.7091$$

$$y - y_1 = m(x - x_1)$$

$$y - 812 = 5.7091(x - 60)$$

$$y - 812 = 5.7091x - 342.546$$

$$y = 5.7091x - 342.546 + 812$$

$$y = 5.7091x + 469.454$$

1. start up cost = \$469.45

2. slope = 5.0791 It represents the cost per shirt (\$5.08)

7.

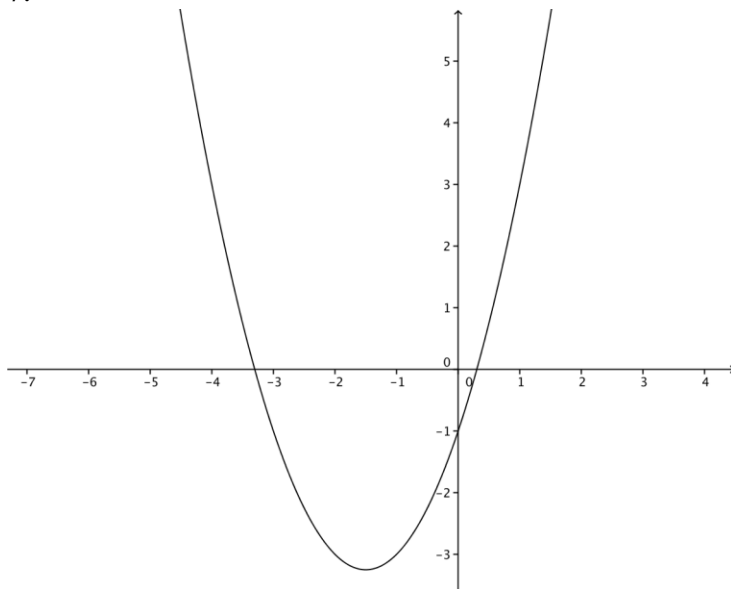

$$y = x^2 + 3x - 1$$

$$x = 0.3, -3.3$$

8.

$$\frac{\frac{6}{7}}{\frac{1}{2}} = \frac{6}{7} \div \frac{1}{2} = \frac{6}{7} \times \frac{2}{1} = \frac{12}{7}$$

9.

$$F = m \cdot a$$

$$\frac{F}{a} = m$$

$$m = \frac{F}{a}$$

$$m = \frac{300}{70} = \frac{30}{7} \approx 4.2857$$

$$m \approx 4.2857$$

10.

$$A = s^2$$

$$256 = s^2$$

$$\sqrt{256} = \sqrt{s^2}$$

$$16 = s$$

The length of one side equals 16 inches,

11. $\frac{3}{1000} = 0.003$

Lesson 10.9
Chapter 10 Review

1. Vertex: The vertex is the point which represents the maximum or minimum value of a parabola. The line of symmetry goes through the vertex and the parabola rises or falls symmetrically on both sides of the vertex.

2. Standard form for a quadratic equation: $y = ax^2 + bx + c$

3. Model: the function that best fits a set of data

4. Discriminant: the value under the radical sign in the quadratic formula, $D = b^2 - 4ac$. The discriminant tells us how many solutions the function will have and whether the solutions will be rational or irrational.

5. $y = x^2 - 6x + 11$

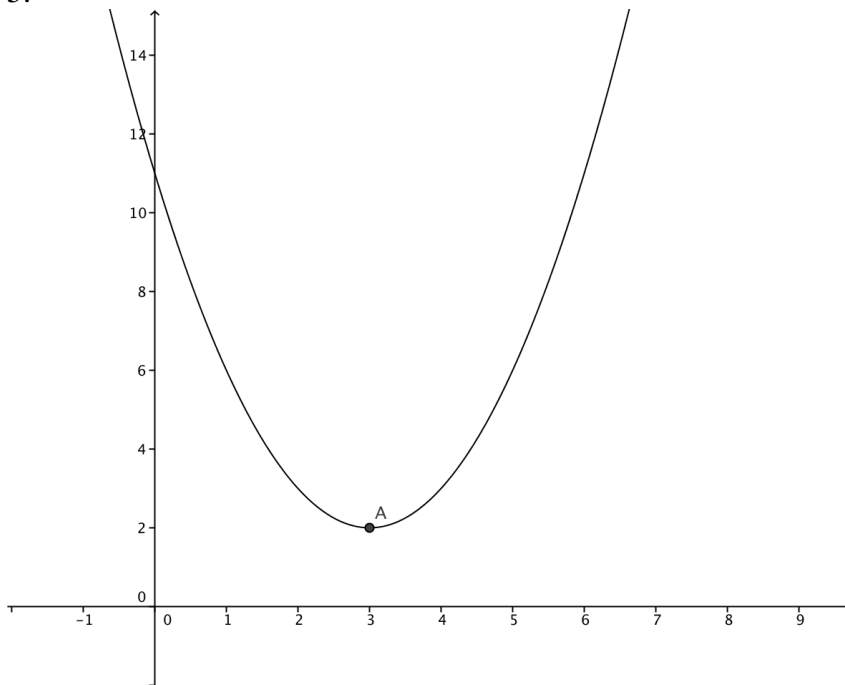

Vertex = (3, 2)

Range: $y \geq 2$

6. $y = -4x^2 + 16x - 19$

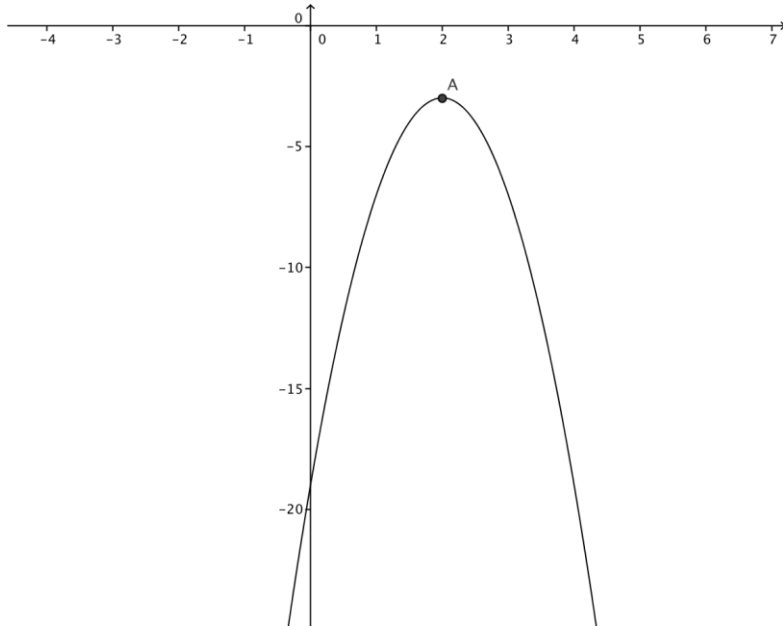

Vertex = $(2, -3)$
Range: $y \leq -3$

7. $y = -x^2 - 2x + 1$

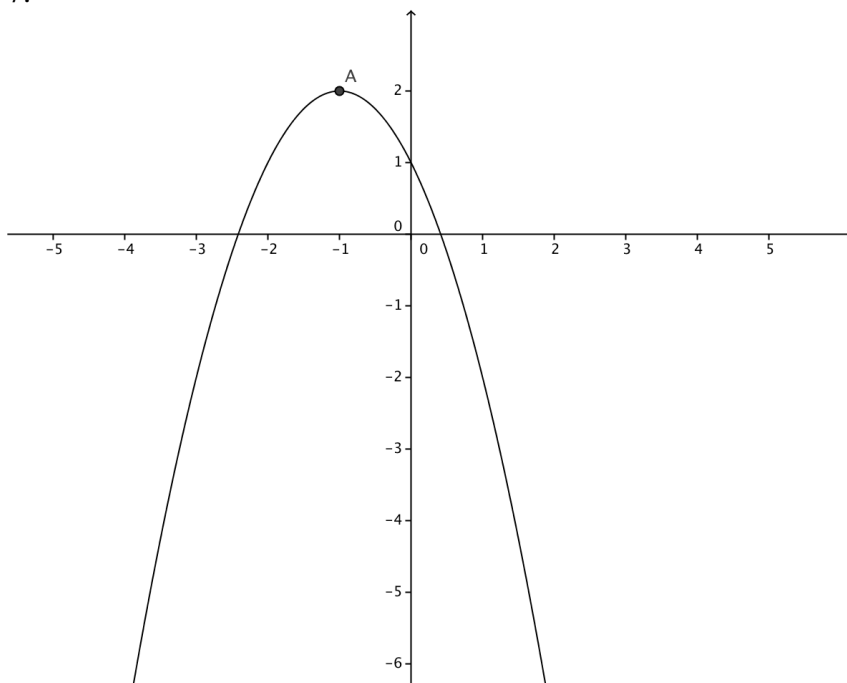

Vertex = $(-1, 2)$
Range: $y \leq 2$

8. $y = \frac{1}{2}x^2 + 8x + 6$

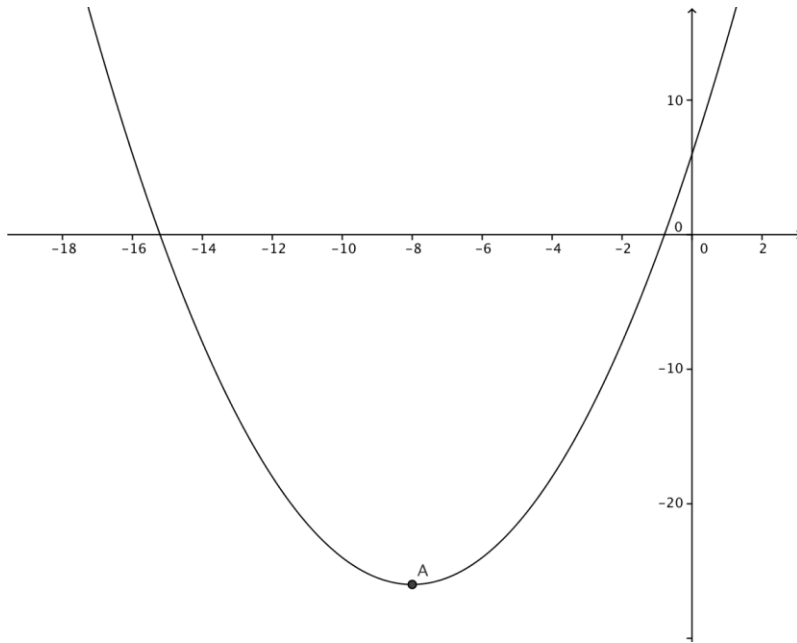

Vertex = $(-8, -26)$
Range: $y \geq -26$

9. $y = x^2 + 4x$

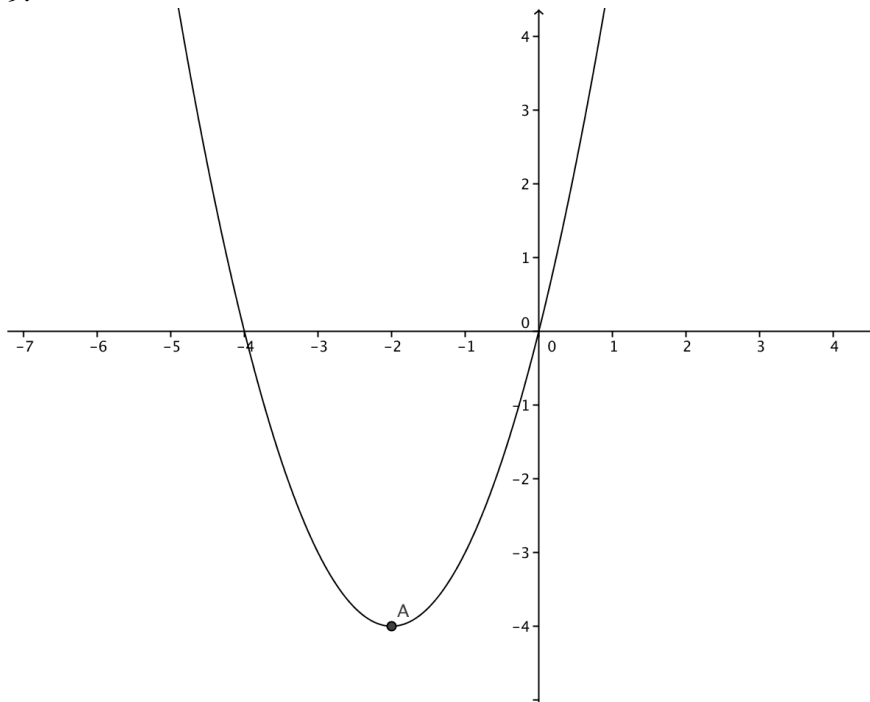

Vertex = $(-2, -4)$
Range: $y \geq -4$

10. $y = -\frac{1}{4}x^2 + 8x - 4$

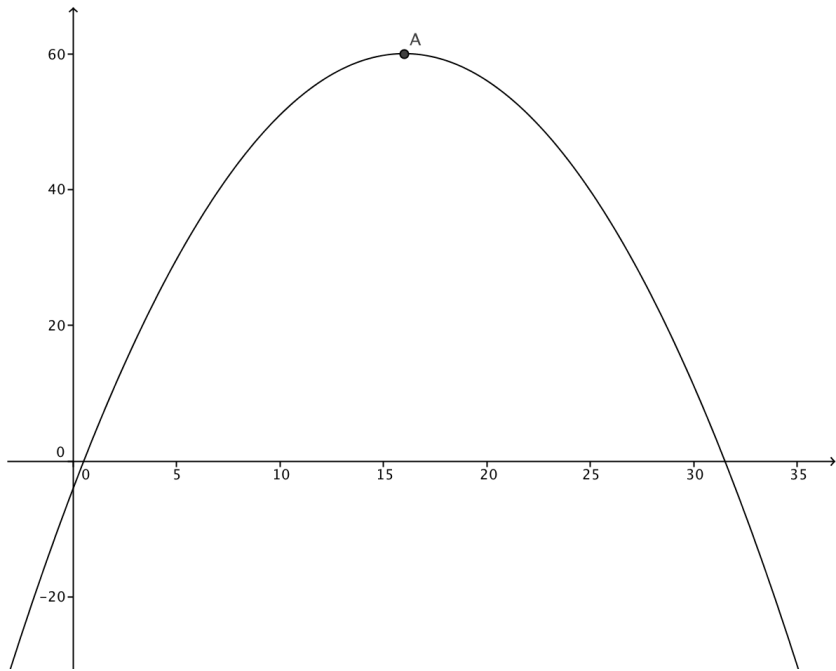

Vertex = (16, 60)

Range: $y \leq 60$

11. $y = (x + 4)^2 + 3$

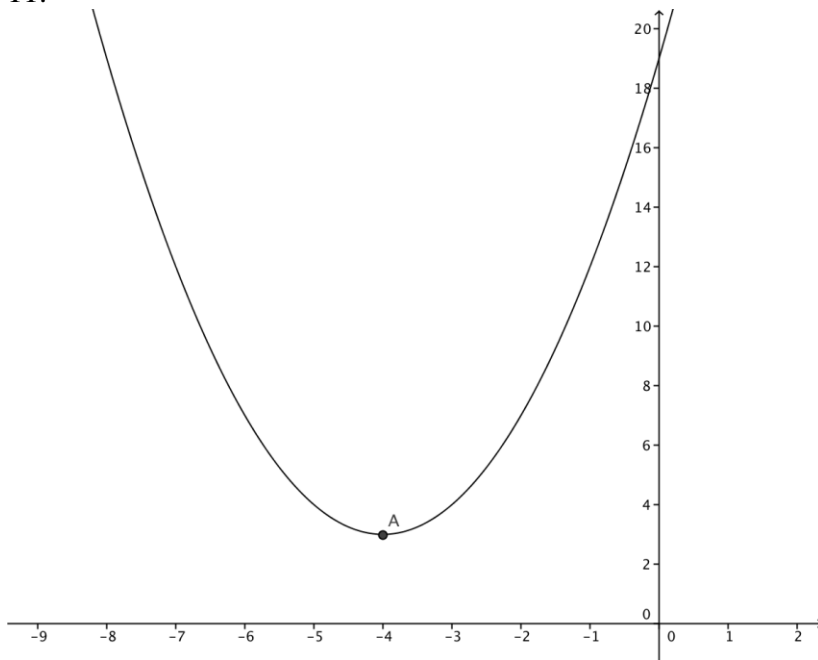

Vertex = (-4, 3)

Range: $y \geq 3$

12. $y = -(x-3)^2 - 6$

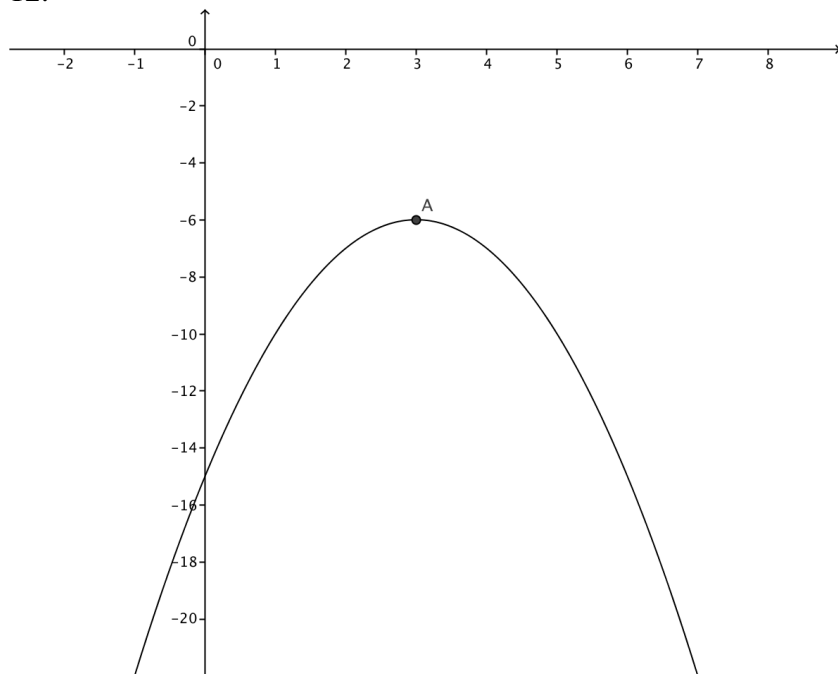

Vertex = (3, -6)
Range: $y \leq -6$

13. $y = (x-2)^2 + 2$

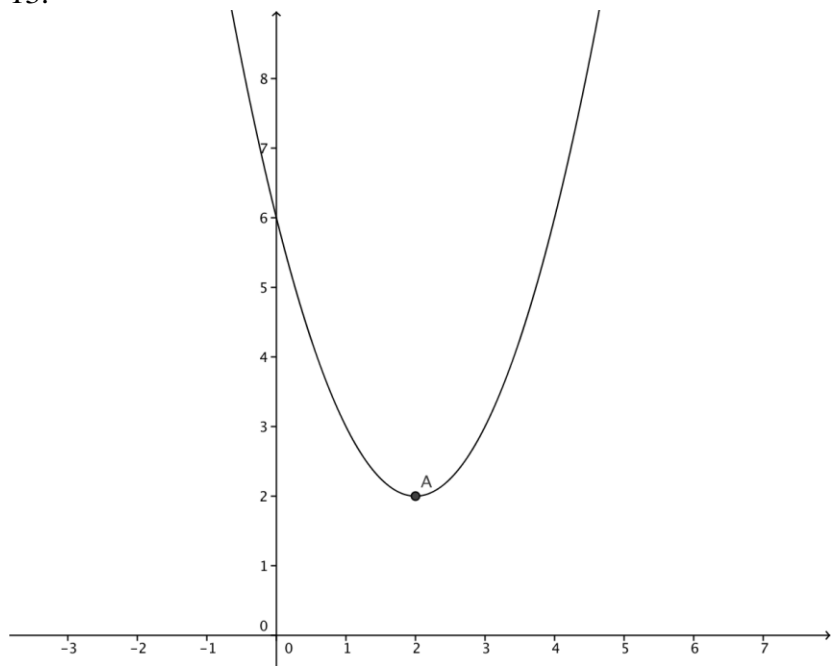

Vertex = (2, 2)
Range: $y \geq 2$

14. $y = -(x+5)^2 - 1$

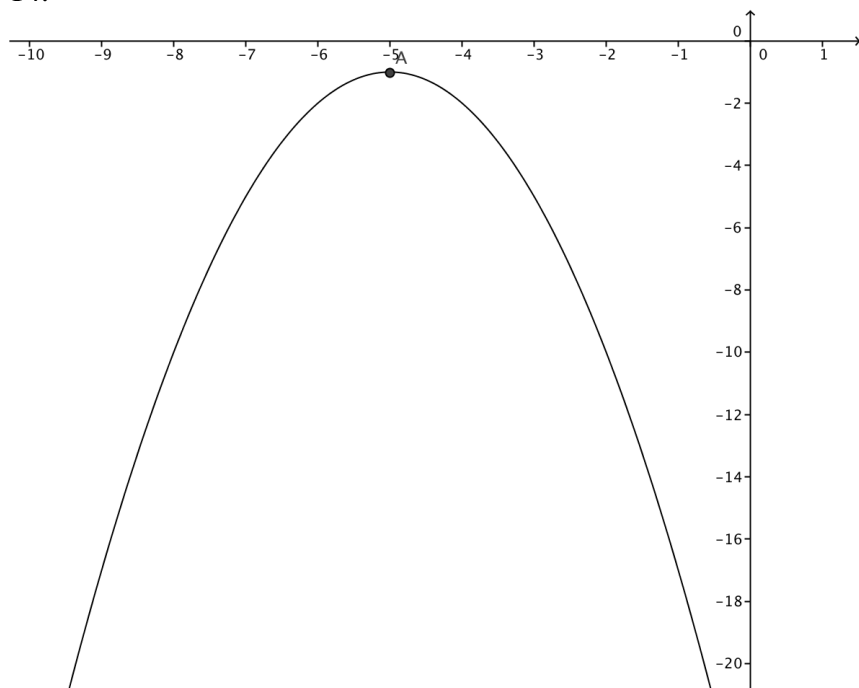

Vertex = $(-5, -1)$
Range: $y \leq -1$

15.

$$x - 24 = -5x^2$$

$$x - 24 + 5x^2 = 0$$

$$5x^2 + x - 24 = 0$$

$$y = 5x^2 + x - 24$$

16.

$$5 + 4a = a^2$$

$$0 = a^2 - 5 - 4a$$

$$y = a^2 - 4a - 5$$

17.

$$-6 - 18a^2 = -528$$

$$-18a^2 = -528 + 6$$

$$-18a^2 = -522$$

$$0 = 18a^2 - 522$$

$$y = 18a^2 - 522$$

18.

$$y = -(x+4)^2 + 2$$

$$y = -(x^2 + 4x + 4x + 16) + 2$$

$$y = -x^2 - 8x - 16 + 2$$

$$y = -x^2 - 8x - 14$$

19. $x^2 - 8x + 87 = 9$

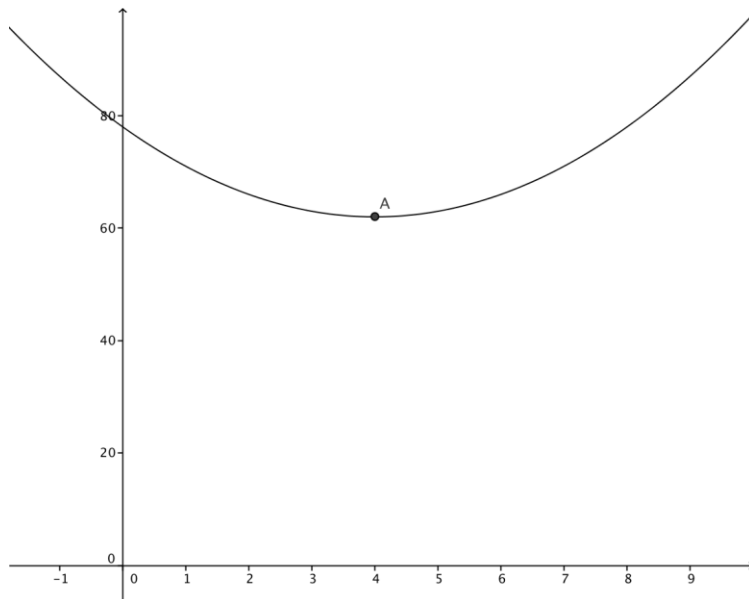

There are no solutions.

20. $23x + x^2 - 104 = 4$

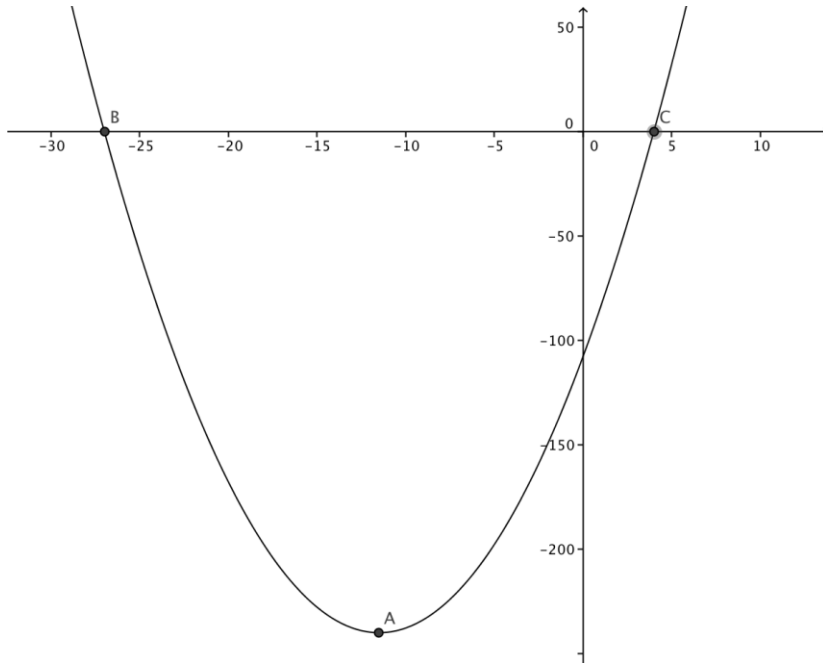

The solutions are $x=4$ and $x=-27$

21. $13 + 26x = -x^2 + 11x$

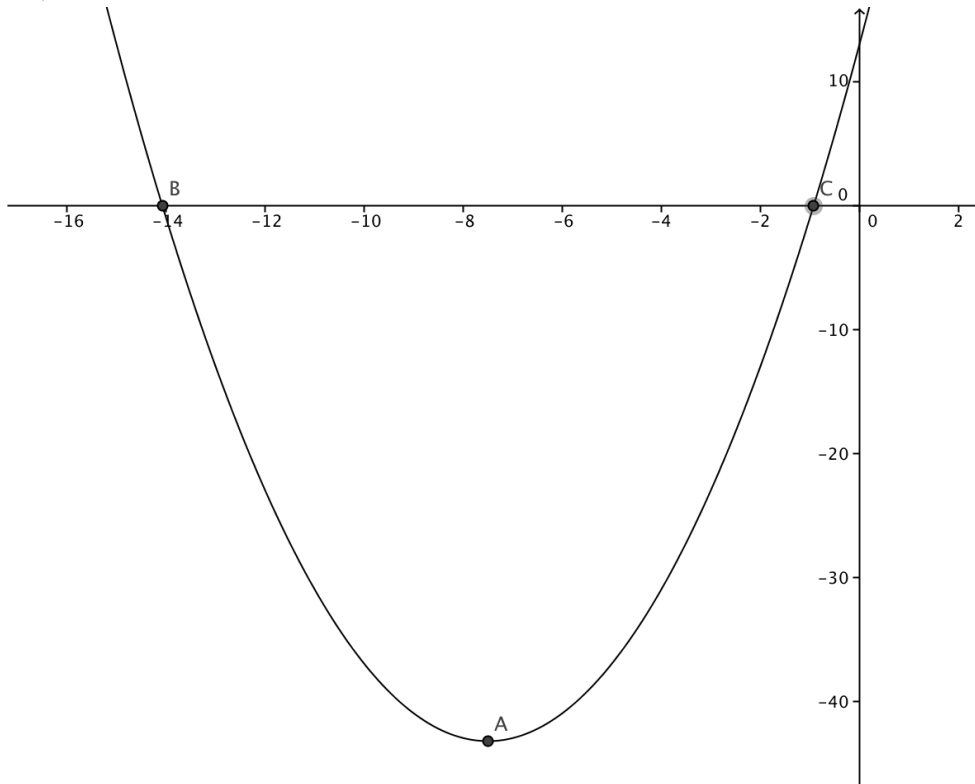

The solutions are $x=-14.08$ and $x=-0.92$

22. $x^2 - 9x = 119$

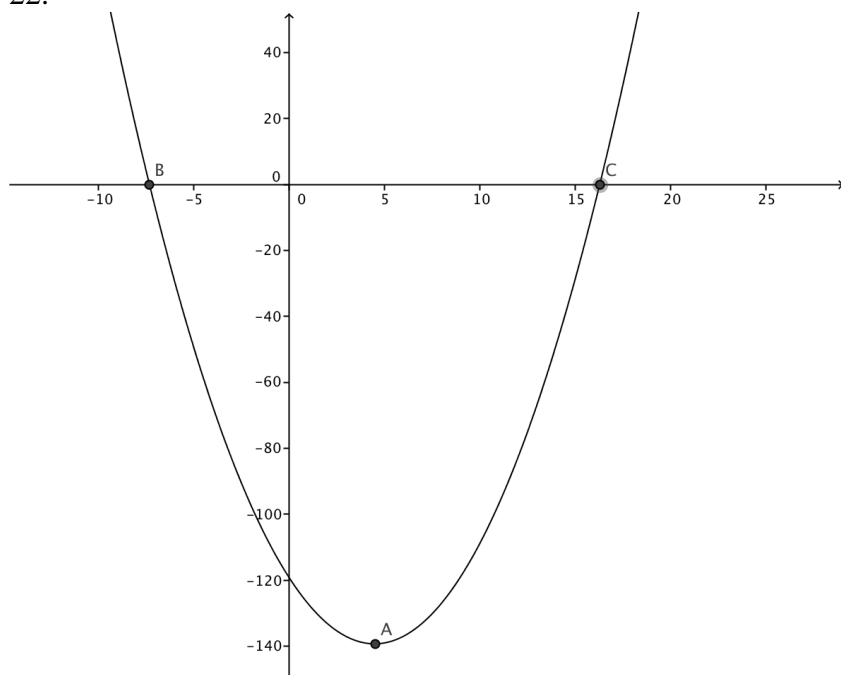

The solutions are $x = -7.3$ and $x = 16.3$

23. $-32 + 6x^2 - 4x = 0$

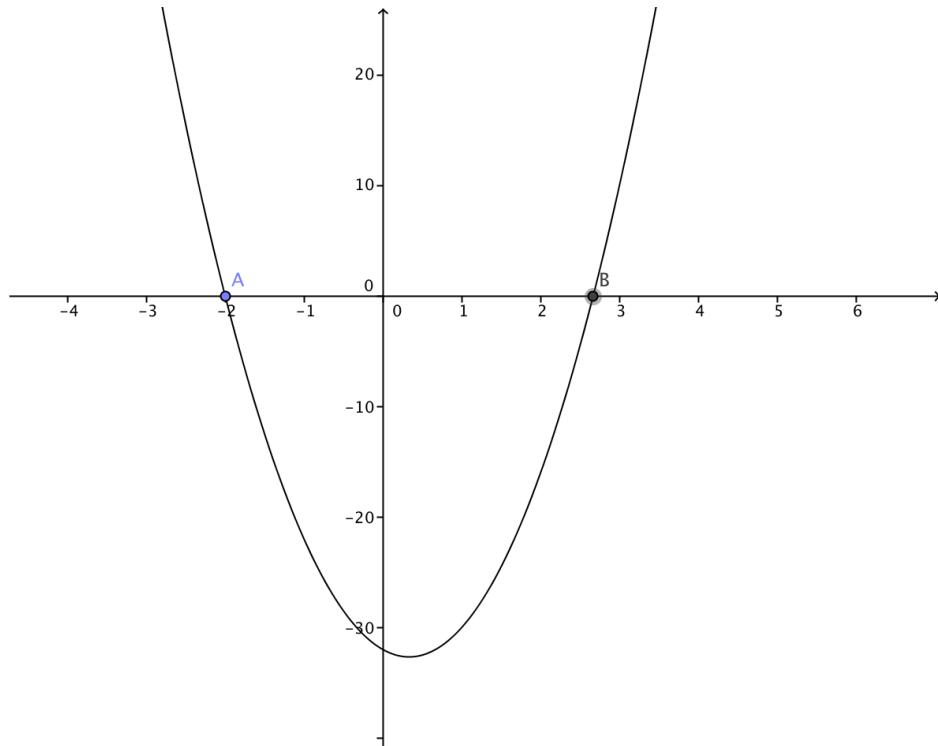

The solutions are $x = -2$ and $x = 2.67$

24.

$$x^2 = 225$$

$$\sqrt{x^2} = \sqrt{225}$$

$$x = \pm 15$$

25.

$$x^2 - 2 = 79$$

$$x^2 = 81$$

$$\sqrt{x^2} = \sqrt{81}$$

$$x = \pm 9$$

26.

$$x^2 + 100 = 200$$

$$x^2 = 100$$

$$\sqrt{x^2} = \sqrt{100}$$

$$x = \pm 10$$

27.

$$8x^2 - 2 = 262$$

$$8x^2 = 264$$

$$x^2 = 33$$

$$\sqrt{x^2} = \sqrt{33}$$

$$x = \sqrt{33}$$

$$x \approx \pm 5.7446$$

28.

$$-6 - 4x^2 = -65$$

$$-4x^2 = -59$$

$$x^2 = 14.75$$

$$\sqrt{x^2} = \sqrt{14.75}$$

$$x = \sqrt{14.75}$$

$$x \approx \pm 3.8406$$

29.

$$703 = 7x^2 + 3$$

$$700 = 7x^2$$

$$100 = x^2$$

$$\sqrt{100} = \sqrt{x^2}$$

$$x = \pm 10$$

30.

$$10 + 6x^2 = 184$$

$$6x^2 = 174$$

$$x^2 = 29$$

$$\sqrt{x^2} = \sqrt{29}$$

$$x = \sqrt{29}$$

$$x \approx \pm 5.3852$$

31.

$$2 + 6x^2 = 152$$

$$6x^2 = 150$$

$$x^2 = 25$$

$$\sqrt{x^2} = \sqrt{25}$$

$$x = \pm 5$$

32.

$$n - 2 = \pm 4$$

$$n^2 - 4n - 3 = 9$$

$$n - 2 = 4$$

$$n^2 - 4n = 12$$

$$n = 6$$

$$n^2 - 4n + 4 = 12 + 4$$

$$n - 2 = -4$$

$$(n - 2)^2 = 16$$

$$n = -2$$

$$\sqrt{(n - 2)^2} = \sqrt{16}$$

$$n - 2 = \pm 4$$

$$n = -2, 6$$

33.

$$h = \sqrt{27} - 5$$
$$h \approx \pm 5.1962 - 5$$

$$h^2 + 10h + 1 = 3$$

$$h^2 + 10h = 2$$

$$h^2 + 10h + 25 = 2 + 25$$

$$(h + 5)^2 = 27$$

$$\sqrt{(h + 5)^2} = \sqrt{27}$$

$$h + 5 = \sqrt{27}$$

$$h = \sqrt{27} - 5$$

$$h \approx 5.1962 - 5$$

$$h \approx 0.1962$$

$$h \approx -5.1962 - 5$$

$$h \approx -10.1962$$

$$h \approx 0.1962, -10.1962$$

34.

$$x + 7 = \pm 9$$

$$x^2 + 14x - 22 = 10$$

$$x^2 + 14x = 32$$

$$x^2 + 14x + 49 = 32 + 49$$

$$(x + 7)^2 = 81$$

$$\sqrt{(x + 7)^2} = \sqrt{81}$$

$$x + 7 = \pm 9$$

$$x + 7 = 9$$

$$x = 2$$

$$x + 7 = -9$$

$$x = -16$$

$$x = 2, -16$$

35.

$$t - 5 = \pm 4$$

$$t^2 - 10t = -9$$

$$t^2 - 10t + 25 = -9 + 25$$

$$(t - 5)^2 = 16$$

$$\sqrt{(t - 5)^2} = \sqrt{16}$$

$$t - 5 = \pm 4$$

$$t - 5 = 4$$

$$t = 9$$

$$t - 5 = -4$$

$$t = 1$$

$$t = 1, 9$$

36.

$$x^2 - 20x + 28 = -8$$

$$x^2 - 20x = -36$$

$$x^2 - 20x + 100 = -36 + 100$$

$$(x - 10)^2 = 64$$

$$(x - 10)^2 - 64 = 0$$

$$y = (x - 10)^2 - 64$$

$$y = a(x - h)^2 + k$$

$$(h, k) = (10, -64)$$

The minimum point of the function is (10,-64)

37.

$$a^2 + 2a - 63 = -5$$

$$a^2 + 2a = 58$$

$$a^2 + 2a + 1 = 58 + 1$$

$$(a + 1)^2 = 59$$

$$(a + 1)^2 - 59 = 0$$

$$y = (a + 1)^2 - 59$$

$$y = a(x - h)^2 + k$$

$$(h, k) = (-1, -59)$$

The minimum point of the function is (-1,-59)

38.

$$x^2 + 6x - 33 = 4$$

$$x^2 + 6x = 37$$

$$x^2 + 6x + 9 = 37 + 9$$

$$(x + 3)^2 = 46$$

$$(x + 3)^2 - 46 = 0$$

$$y = (x + 3)^2 - 46$$

$$y = a(x - h)^2 + k$$

$$(h, k) = (-3, -46)$$

The minimum point of the function is (-3,-46)

39.

$$4x^2 - 3x = 45$$

$$4x^2 - 3x - 45 = 0$$

$$y = 4x^2 - 3x - 45$$

$$y = \frac{-b \pm \sqrt{b^2 - 4ac}}{2a}$$

$$y = \frac{-(-3) \pm \sqrt{(-3)^2 - 4(4)(-45)}}{2(4)}$$

$$y = \frac{3 \pm \sqrt{9 + 720}}{8}$$

$$y = \frac{3 \pm \sqrt{729}}{8}$$

$$y = \frac{3 + \sqrt{729}}{8} = \frac{3 + 27}{8} = \frac{30}{8} = 3.75$$

$$y = \frac{3 - \sqrt{729}}{8} = \frac{3 - 27}{8} = \frac{-24}{8} = -3$$

$$y = 3.75, -3$$

40.

$$-5x + 11x^2 = 15$$

$$11x^2 - 5x - 15 = 0$$

$$y = 11x^2 - 5x - 15$$

$$y = \frac{-b \pm \sqrt{b^2 - 4ac}}{2a}$$

$$y = \frac{-(-5) \pm \sqrt{(-5)^2 - 4(11)(-15)}}{2(11)}$$

$$y = \frac{5 \pm \sqrt{25 + 660}}{22}$$

$$y = \frac{5 \pm \sqrt{685}}{22}$$

$$y = \frac{5 + \sqrt{685}}{22} \approx \frac{5 + 26.1725}{22} \approx \frac{31.1725}{22} \approx 1.4169$$

$$y = \frac{5 - \sqrt{685}}{22} \approx \frac{5 - 26.1725}{22} \approx \frac{-21.1725}{22} \approx -0.9624$$

$$y \approx 1.4169, -0.9624$$

41.

$$-3r = 12r^2 - 3$$

$$0 = 12r^2 - 3 + 3r$$

$$y = 12r^2 + 3r - 3$$

$$y = \frac{-b \pm \sqrt{b^2 - 4ac}}{2a}$$

$$y = \frac{-3 \pm \sqrt{(3)^2 - 4(12)(-3)}}{2(12)}$$

$$y = \frac{-3 \pm \sqrt{9 + 144}}{24}$$

$$y = \frac{-3 \pm \sqrt{153}}{24}$$

$$y = \frac{-3 + \sqrt{153}}{24} \approx \frac{-3 + 12.3693}{24} \approx \frac{9.3693}{24} \approx 0.3904$$

$$y = \frac{-3 - \sqrt{153}}{24} \approx \frac{-3 - 12.3693}{24} \approx \frac{-15.3693}{24} \approx -0.6404$$

$$y \approx 0.3904, -0.6404$$

42.

$$2m^2 + 10m = 8$$

$$2m^2 + 10m - 8 = 0$$

$$y = 2m^2 + 10m - 8$$

$$y = \frac{-b \pm \sqrt{b^2 - 4ac}}{2a}$$

$$y = \frac{-10 \pm \sqrt{10^2 - 4(2)(-8)}}{2(2)}$$

$$y = \frac{-10 \pm \sqrt{100 + 64}}{4}$$

$$y = \frac{-10 \pm \sqrt{164}}{4}$$

$$y = \frac{-10 + \sqrt{164}}{4} \approx \frac{-10 + 12.8062}{4} \approx \frac{2.8062}{4} \approx 0.7016$$

$$y = \frac{-10 - \sqrt{164}}{4} \approx \frac{-10 - 12.8062}{4} \approx \frac{-22.8062}{4} \approx -5.7016$$

$$y \approx 0.7016, -5.7016$$

43.

$$7c^2 + 14c - 28 = -7$$

$$7c^2 + 14c - 21 = 0$$

$$y = 7c^2 + 14c - 21$$

$$y = \frac{-b \pm \sqrt{b^2 - 4ac}}{2a}$$

$$y = \frac{-14 \pm \sqrt{14^2 - 4(7)(-21)}}{2(7)}$$

$$y = \frac{-14 \pm \sqrt{196 + 588}}{14}$$

$$y = \frac{-14 \pm \sqrt{784}}{14}$$

$$y = \frac{-14 + \sqrt{784}}{14} = \frac{-14 + 28}{14} = \frac{14}{14} = 1$$

$$y = \frac{-14 - \sqrt{784}}{14} = \frac{-14 - 28}{14} = \frac{-42}{14} = -3$$

$$y = 1, -3$$

44.

$$3w^2 - 15 = -3w$$

$$3w^2 - 15 + 3w = 0$$

$$y = 3w^2 + 3w - 15$$

$$y = \frac{-b \pm \sqrt{b^2 - 4ac}}{2a}$$

$$y = \frac{-3 \pm \sqrt{3^2 - 4(3)(-15)}}{2(3)}$$

$$y = \frac{-3 \pm \sqrt{9 + 180}}{6}$$

$$y = \frac{-3 \pm \sqrt{189}}{6}$$

$$y = \frac{-3 + \sqrt{189}}{6} \approx \frac{-3 + 13.7477}{6} \approx \frac{10.7477}{6} \approx 1.7913$$

$$y = \frac{-3 - \sqrt{189}}{6} \approx \frac{-3 - 13.7477}{6} \approx \frac{-16.7477}{6} \approx -2.7913$$

$$y \approx 1.7913, -2.7913$$

45.

$$4x^2 - 4x + 1 = 0$$

$$D = b^2 - 4ac$$

$$D = (-4)^2 - 4(4)(1)$$

$$D = 16 - 16$$

$$D = 0$$

The equation will have only 1 solution and it will be rational.

46.

$$2x^2 - x - 3 = 0$$

$$D = b^2 - 4ac$$

$$D = (-1)^2 - 4(2)(-3)$$

$$D = 1 + 24$$

$$D = 25$$

The equation will have 2 solutions and they will be rational.

47.

$$-2x^2 - x - 1 = -2$$

$$-2x^2 - x + 1 = 0$$

$$D = b^2 - 4ac$$

$$D = (-1)^2 - 4(-2)(1)$$

$$D = 1 + 8$$

$$D = 9$$

The equation will have 2 solutions and they will be rational.

48.

$$4x^2 - 8x + 4 = 0$$

$$D = b^2 - 4ac$$

$$D = (-8)^2 - 4(4)(4)$$

$$D = 64 - 64$$

$$D = 0$$

The equation will have only 1 solution and it will be rational.

49.

$$-5x^2 + 10x - 5 = 0$$

$$D = b^2 - 4ac$$

$$D = (10)^2 - 4(-5)(-5)$$

$$D = 100 - 100$$

$$D = 0$$

The equation will have only 1 solution and it will be rational.

50.

$$4x^2 + 3x + 6 = 0$$

$$D = b^2 - 4ac$$

$$D = (3)^2 - 4(4)(6)$$

$$D = 9 - 96$$

$$D = -87$$

The equation will have no real solutions.

51.

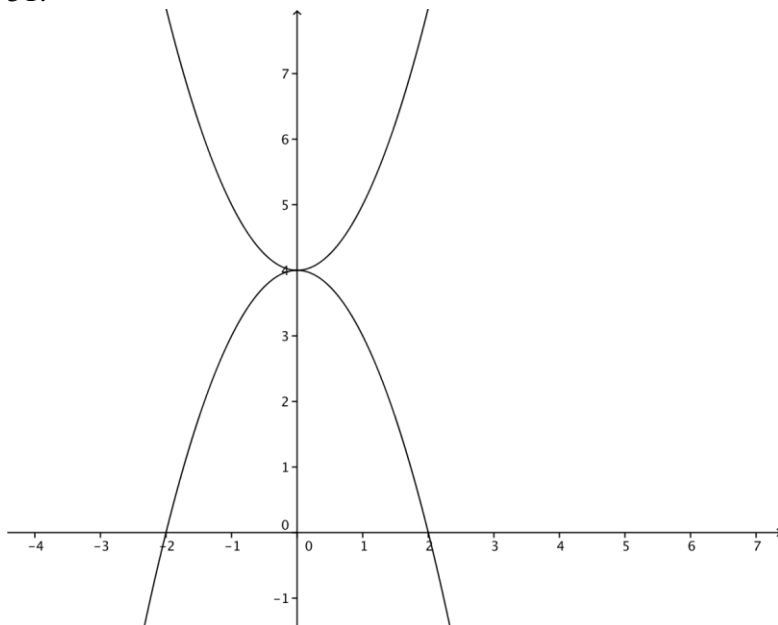

The graph on top is $y = x^2 + 4$, while the lower graph is $y = -x^2 + 4$

While they have the same vertex and y-intercept, the first parabola opens upward with its vertex as a minimum and the second parabola opens downward with its vertex as a maximum. As a result of their opposite orientations the first equation will have no solutions but the second equation will have two.

52.

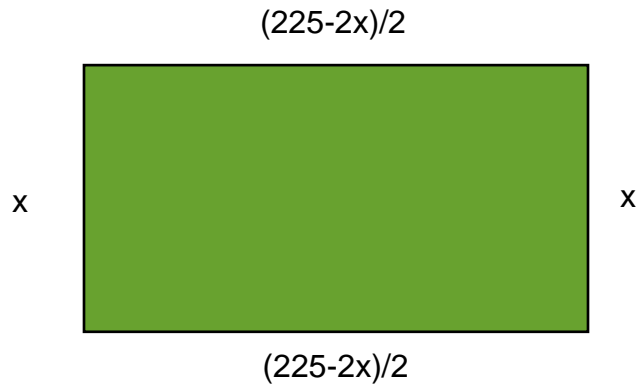

$$A = x * \frac{(225 - 2x)}{2}$$

$$A = \frac{1}{2} * x(225 - 2x)$$

$$A = \frac{1}{2} * 225x - 2x^2$$

$$A = 112.5x - x^2$$

$$0 = -x^2 + 112.5x$$

$$0 = -1(x^2 - 112.5x)$$

$$0 + 3164.0625(-1) = -1(x^2 - 112.5x + 3164.0625)$$

$$-3164.0625 = -1(x - 56.25)^2$$

$$3164.0625 = (x - 56.25)^2$$

$$\sqrt{3164.0625} = \sqrt{(x - 56.25)^2}$$

$$56.25 = x - 56.25$$

$$112.5 = x$$

The dimensions of the garden are 112.5 ft by 112.5 ft

53.

$$h(t) = -\frac{1}{2}(g)t^2 + v_0t + h_0$$

$$h(t) = -\frac{1}{2}(9.8)t^2 + 0t + 70$$

1. $h(t) = -4.9t^2 + 70$

2. The leading coefficient is -4.9 It tells us that the parabola will open downward (because it is negative) and will be narrow about its line of symmetry (because it is less than -1).

$$h(t) = -4.9t^2 + 70$$

$$0 = -4.9t^2 + 0t + 70$$

$$-70 = -4.9t^2 + 0t$$

$$-70 = -4.9(t^2 - 0t)$$

$$-70 + 0 = -4.9(t^2 - 0t + 0)$$

$$-70 = -4.9(t - 0)^2$$

$$0 = -4.9(t - 0)^2 + 70$$

$$y = a(x - h) + k$$

3. $(h, k) = (0, 70)$

The maximum height of the ball is 70 meters.

$$h(t) = -4.9t^2 + 70$$

$$h(t) = -4.9(0.65)^2 + 70$$

$$h(t) = -4.9(.4225) + 70$$

$$h(t) = -2.07025 + 70$$

4. $h(t) = 67.92975$

After 0.65 seconds the ball will be 67.92975 meters from the ground.

$$h(t) = -4.9t^2 + 70$$

$$0 = -4.9t^2 + 70$$

$$-70 = -4.9t^2$$

$$4.9t^2 = 70$$

$$t^2 = 14.2857$$

$$\sqrt{t^2} = \sqrt{14.2857}$$

5. $t = 3.7796$

The ball will reach the ground at approximately 3.7796 seconds.

54.

1. The best function for this data seems to be a linear regression.

2.

$$y = mx + b$$

$$m = 9.8286$$

$$b = -914.9524$$

$$y = 9.8286x - 914.9524$$

The function of best fit is $y = 9.8286x - 914.9524$

3.

$$y = 9.8286x - 914.9524$$

$$x = 2012 = 112$$

$$y = 9.8286(112) - 914.9524$$

$$y = 1100.8032 - 914.9524$$

$$y = 185.8508$$

Based on the equation, in 2012 a person would be playing approximately 186 hours of video games.

4. Yes this seems like a viable answer, both because the math fits with the data we already have, (a linear increasing trend) and because of the reality of the greater availability and popularity of video games in recent years. One would expect an substantial increase.

55.

1.

$$y = mx + b$$

$$m = 1.5617$$

$$b = 15.22$$

$$y = 1.5617x + 15.22$$

$$x = 2008 = 18$$

$$y = 1.5617(18) + 15.22$$

$$y = 28.1106 + 15.22$$

$$y = 43.3306$$

Based on this model the amount spent in 2008 would be approximately 43.3 billion.

2.

$$y = ax^2 + bx + c$$

$$a = 0.0919$$

$$b = 0.8266$$

$$c = 16.0776$$

$$y = 0.0919x^2 + 0.8266x + 16.0776$$

$$x = 2008 = 18$$

$$y = 0.0919(18)^2 + 0.8266(18) + 16.0776$$

$$y = 0.0919(324) + 14.8788 + 16.0776$$

$$y = 29.7756 + 14.8788 + 16.0776$$

$$y = 60.732$$

Based on this model the amount spent in 2008 would be approximately 60.7 billion.

3. The linear model seems more accurate.

$$y = 1.5617x + 15.22$$

$$x = 2012 = 22$$

$$y = 1.5617(22) + 15.22$$

$$y = 34.3574 + 15.22$$

$$y = 49.5774$$

Based on this model the amount spent in 2012 would be approximately 49.6 billion.

4. The amount of money spent in 2012 could be changed by any number of factors. More or less books printed. The price of books going up or down. The rate of books being bought changes dramatically making the equation an inaccurate predictor.

56.

1.

$$y = ax^2 + bx + c$$

$$a = -1.6607$$

$$b = 6549.6902$$

$$c = -6450876.9468$$

$$y = -1.6607x^2 + 6549.6902x - 6,450,876.9468$$

2.

$$y = -1.6607x^2 + 6549.6902x - 6,450,876.9468$$

$$0 = -1.6607x^2 + 6549.6902x - 6,450,876.9468$$

$$6,450,876.9468 = -1.6607x^2 + 6549.6902x$$

$$6,450,876.9468 = -1.6607(x^2 - 3943.9334x)$$

$$6,450,876.9468 + 3888652.6659(-1.6607) = -1.6607(x^2 - 3943.9334x + 3888652.6659)$$

$$-7008.5355 = -1.6607(x - 1971.9667)$$

$$0 = -1.6607(x - 1971.9667) + 7008.5355$$

$$y = a(x - h)^2 + k$$

$$(h, k) = (1972, 7009)$$

BASED ON THE MODEL the maximum number of hospitals is 7009.

3. BASED ON THE MODEL the maximum occurs in 1972.

4.

$$y = -1.6607x^2 + 6549.6902x - 6,450,876.9468$$

$$7000 = -1.6607x^2 + 6549.6902x - 6,450,876.9468$$

$$0 = -1.6607x^2 + 6549.6902x - 6,450,876.9468 - 7000$$

$$0 = -1.6607x^2 + 6549.6902x - 6457876.9468$$

$$y = \frac{-b \pm \sqrt{b^2 - 4ac}}{2a}$$

$$y = \frac{-6549.6902 \pm \sqrt{6549.6902^2 - 4(-1.6607)(-6457876.9468)}}{2(-1.6607)}$$

$$y = \frac{-6549.6902 \pm \sqrt{42898441.716 - 42898384.9822}}{-3.3214}$$

$$y = \frac{-6549.6902 \pm \sqrt{56.7338}}{-3.3214}$$

$$y = \frac{-6549.6902 + \sqrt{56.7338}}{-3.3214} \approx \frac{-6549.6902 + 7.5322}{-3.3214} \approx \frac{-6542.158}{-3.3214} \approx 1969.6989$$

$$y = \frac{-6549.6902 - \sqrt{56.7338}}{-3.3214} \approx \frac{-6549.6902 - 7.5322}{-3.3214} \approx \frac{-6557.2224}{-3.3214} \approx 1974.2344$$

$$y \approx 1970, 1974$$

5. The trend appears to be that the # of hospitals was increasing before the 1980's and has been decreasing since.

57.

1. The best model for the data seems to be an exponential function.

2.

$$y = ax^2 + bx + c$$

$$a = 0.8764$$

$$b = -10.4074$$

$$c = 34.1418$$

$$y = 0.8764x^2 - 10.4074x + 34.1418$$

$$x = 7$$

$$y = 0.8764(7^2) - 10.4074(7) + 34.1418$$

$$y = 42.9436 - 72.8518 + 34.1418$$

$$y = 4.2336$$

Based on this model, the length of the seventh swing is approximately 4.2336

3.

$$y = a(b)^x$$

$$a = 38.4606$$

$$b = 0.65$$

$$y = 38.4606(0.65)^x$$

$$x = 7$$

$$y = 38.4606(0.65)^7$$

$$y = 38.4606(0.049)$$

$$y = 1.8846$$

Based on this model, the length of the seventh swing is approximately 1.8846

Lesson 10.10
Chapter 10 Test

1. False, the vertex determines the range of the quadratic function.

2. When $a = -\frac{1}{3}$ the parabola opens downward and the vertex is a maximum (because a is negative). In addition we know that the parabola will be wide about its line of symmetry (because $-1 < a < 1$).

3.

$$0 = -2x^2 + 3x - 2$$

$$a = -2$$

$$b = 3$$

$$c = -2$$

$$D = b^2 - 4ac$$

$$D = 3^2 - 4(-2)(-2)$$

$$D = 9 - 16$$

$$D = -7$$

This equation has NO real solutions.

4.

1.

$$h(t) = -\frac{1}{2}(g)t^2 + v_0t + h_0$$

$$h(t) = -\frac{1}{2}(32)t^2 + 45t + 4$$

$$h(t) = -16t^2 + 45t + 4$$

2.

$$h(t) = -16t^2 + 45t + 4$$

$$0 = -16t^2 + 45t + 4$$

$$-4 = -16t^2 + 45t$$

$$-4 = -16(t^2 - 2.8125t)$$

$$-4 + 1.9775(-16) = -16(t^2 - 2.8125t + 1.9775)$$

$$-33.6625 = -16(t - 1.4063)^2$$

$$0 = -16(t - 1.4063)^2 + 33.6625$$

$$y = -16(t - 1.4063)^2 + 33.6625$$

$$y = a(x - h)^2 + k$$

$$(h, k) = (1.4063, 33.6625)$$

The maximum height of the ball is 33.6525 feet.

3.

$$h(t) = -16t^2 + 45t + 4$$

$$10 = -16t^2 + 45t + 4$$

$$0 = -16t^2 + 45t - 6$$

$$y = \frac{-b \pm \sqrt{b^2 - 4ac}}{2a}$$

$$y = \frac{-45 \pm \sqrt{45^2 - 4(-16)(-6)}}{2(-16)}$$

$$y = \frac{-45 \pm \sqrt{2025 - 384}}{-32}$$

$$y = \frac{-45 \pm \sqrt{1641}}{-32}$$

$$y = \frac{-45 + \sqrt{1641}}{-32} \approx \frac{-45 + 40.5093}{-32} \approx \frac{-4.4907}{-32} \approx 0.1403$$

$$y = \frac{-45 - \sqrt{1641}}{-32} \approx \frac{-45 - 40.5093}{-32} \approx \frac{-85.5093}{-32} \approx 2.6722$$

$$y \approx 0.1403, 2.6722$$

The ball will reach 10 ft at 0.1403 and 2.6722 seconds.

4. No the ball will not reach 36.7 ft because the maximum height of the ball is 33.6525 ft.

$$h(t) = -16t^2 + 45t + 4$$

$$0 = -16t^2 + 45t + 4$$

$$y = \frac{-b \pm \sqrt{b^2 - 4ac}}{2a}$$

$$y = \frac{-45 \pm \sqrt{45^2 - 4(-16)(4)}}{2(-16)}$$

$$y = \frac{-45 \pm \sqrt{2025 + 256}}{-32}$$

$$y = \frac{-45 \pm \sqrt{2281}}{-32}$$

$$y = \frac{-45 + \sqrt{2281}}{-32} \approx \frac{-45 + 47.7598}{-32} \approx \frac{50.5196}{-32} \approx -1.5787$$

$$y = \frac{-45 - \sqrt{2281}}{-32} \approx \frac{-45 - 47.7598}{-32} \approx \frac{-92.7598}{-32} \approx 2.8987$$

5. $y \approx -1.5787, 2.8987$

The ball will hit the ground at 2.8987

5.

$$2x^2 = 2x + 40$$

$$2x^2 - 2x - 40 = 0$$

$$2(x^2 - x - 20) = 0$$

$$2(x - 5)(x + 4) = 0$$

$$x - 5 = 0$$

$$x = 5$$

$$x + 4 = 0$$

$$x = -4$$

$$x = 5, -4$$

6.

$$11j^2 = j + 24$$

$$11j^2 - j - 24 = 0$$

$$y = \frac{-b \pm \sqrt{b^2 - 4ac}}{2a}$$

$$y = \frac{-(-1) \pm \sqrt{(-1)^2 - 4(11)(-24)}}{2(11)}$$

$$y = \frac{1 \pm \sqrt{1 + 1056}}{22}$$

$$y = \frac{1 \pm \sqrt{1057}}{22}$$

$$y = \frac{1 + \sqrt{1057}}{22} \approx \frac{1 + 32.5115}{22} \approx \frac{33.5115}{22} \approx 1.5233$$

$$y = \frac{1 - \sqrt{1057}}{22} \approx \frac{1 - 32.5115}{22} \approx \frac{-31.5115}{22} \approx -1.4323$$

$$y \approx 1.5233, -1.4323$$

7.

$$g^2 = 1$$

$$\sqrt{g^2} = \sqrt{1}$$

$$g = \pm 1$$

8.

$$-11r^2 - 5 = -178$$

$$-11r^2 = -173$$

$$r^2 = \frac{173}{11}$$

$$\sqrt{r^2} = \sqrt{\frac{173}{11}}$$

$$r = \sqrt{\frac{173}{11}}$$

$$r \approx \pm 3.9658$$

9.

$$x^2 + 8x - 65 = -8$$

$$x^2 + 8x - 57 = 0$$

$$x^2 + 8x = 57$$

$$x^2 + 8x + 16 = 57 + 16$$

$$(x + 4)^2 = 73$$

$$\sqrt{(x + 4)^2} = \sqrt{73}$$

$$x + 4 = \sqrt{73}$$

$$x + 4 \approx \pm 8.544$$

$$x + 4 \approx 8.544$$

$$x \approx 4.544$$

$$x + 4 \approx -8.544$$

$$x \approx -12.544$$

$$x \approx 4.544, -12.544$$

10.

$$y = -(x - 6)^2 + 5$$

$$y = a(x - h) + k$$

$$a = -1$$

$$h = 6$$

$$k = 5$$

$$\text{Vertex} = (6, 5)$$

The parabola opens downward.

The vertex is a maximum.

11. $y = (x + 2)^2 - 3$

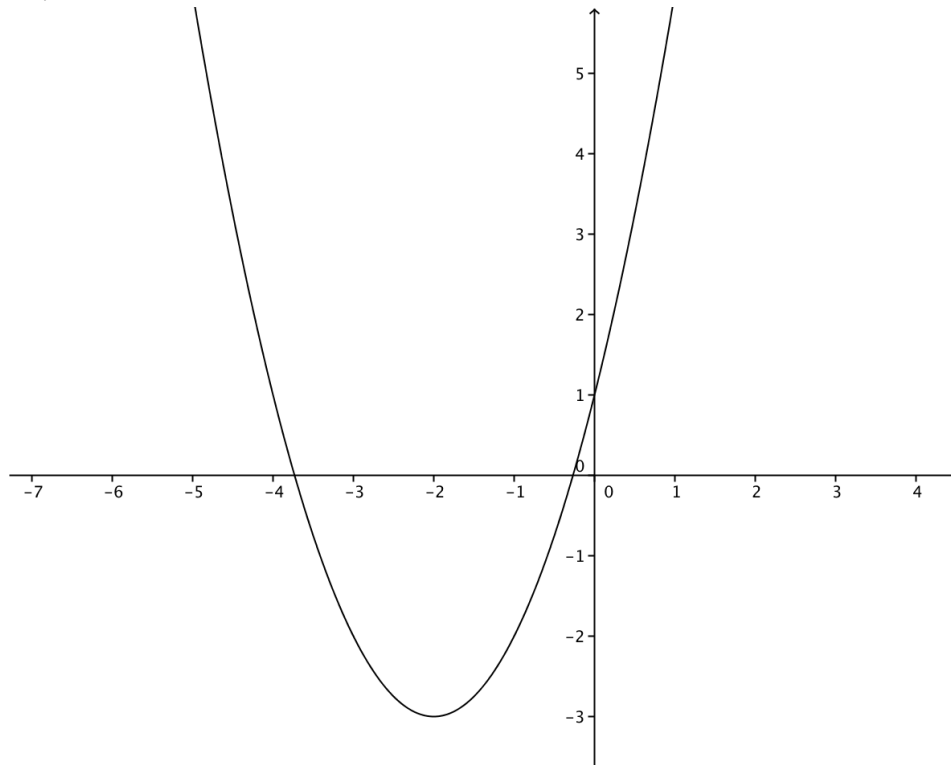

12.

$$-5x^2 - 6x = 1$$

$$-5x^2 - 6x - 1 = 0$$

$$D = b^2 - 4ac$$

$$D = (-6)^2 - 4(-5)(-1)$$

$$D = 36 - 20$$

$$D = 16$$

The equation has two real solutions.

13. If $D = -14$ then the quadratic equations has no real solutions.

14.

$$y - 7 = -2(x + 1)^2$$

$$y - 7 = -2(x^2 + 2x + 1)$$

$$y - 7 = -2x^2 - 4x - 2$$

$$y = -2x^2 - 4x + 5$$

15. $y = -x^2 + 2x - 2$

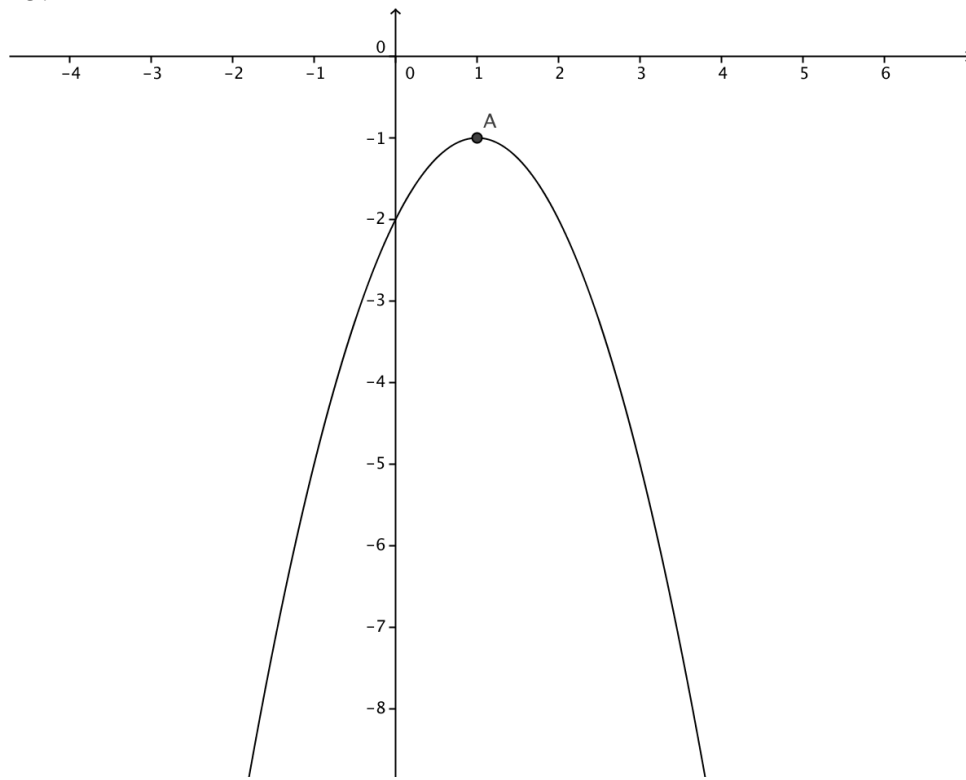

Vertex = (1, -1)
Range: $y \leq -1$

16. $y = \frac{1}{2}x^2 + 4x + 5$

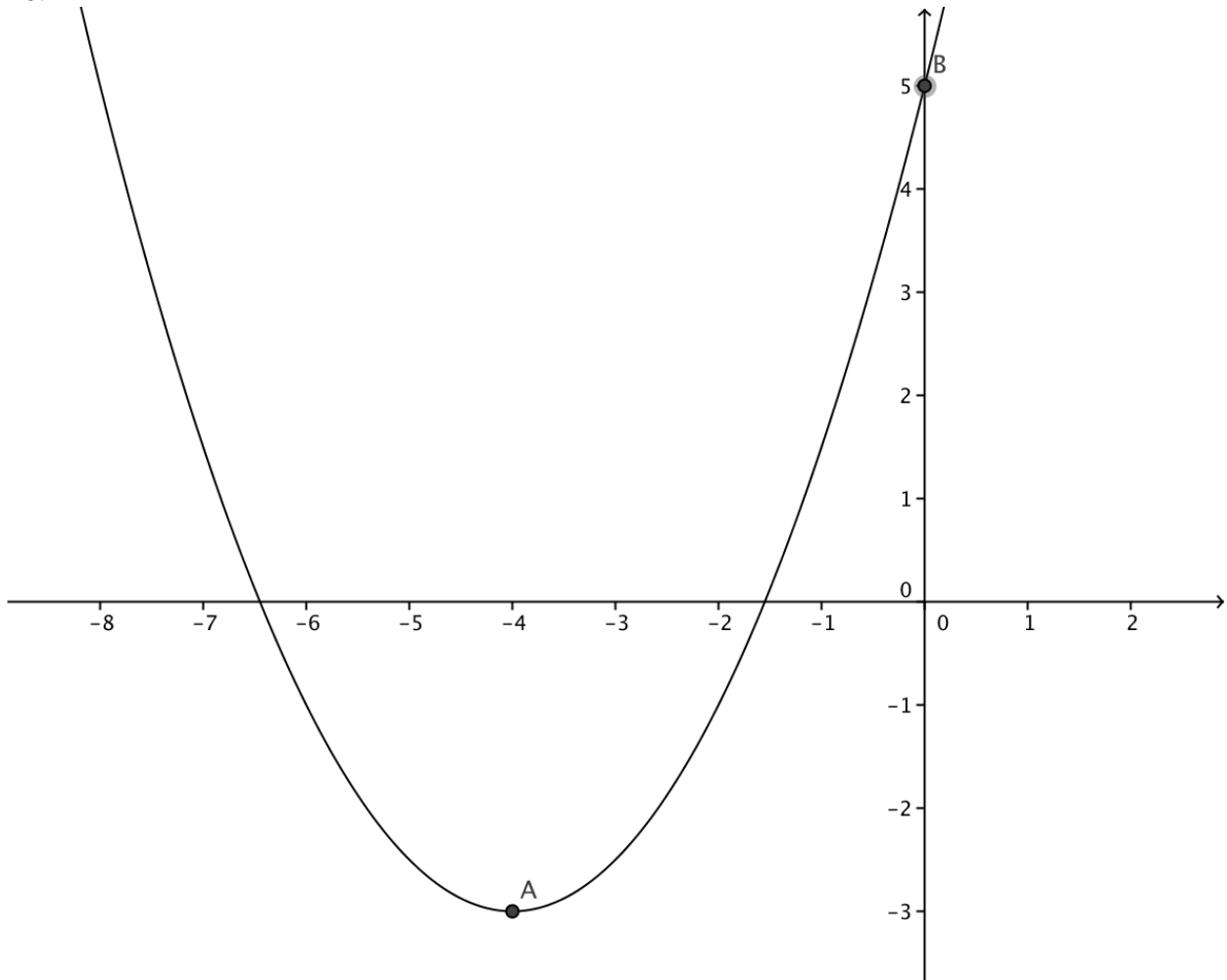

Range: $y \geq -3$
y-intercept: (0,5)

17.

1.

$$y = mx + b$$

$$m = -0.1391$$

$$b = 222.2557$$

$$y = -0.1391x + 222.2557$$

$$x = 1999 = 99$$

$$y = -0.1391(99) + 222.2557$$

$$y = -13.7709 + 222.2557$$

$$y = 208.4848$$

2.

$$y = ax^2 + bx + c$$

$$a = -0.1763$$

$$b = 31.0581$$

$$c = -1151.7613$$

$$y = -0.1763x^2 + 31.0581x - 1151.7613$$

$$x = 1999 = 99$$

$$y = -0.1763(99^2) + 31.0581(99) - 1151.7613$$

$$y = -0.1763(9801) + 3074.7519 - 1151.7613$$

$$y = -1727.9163 + 3074.7519 - 1151.7613$$

$$y = 195.0743$$

3.

$$y = a(b)^x$$

$$a = 222.9965$$

$$b = 0.9993$$

$$y = 222.9965(0.9993)^x$$

$$x = 1999 = 99$$

$$y = 222.9965(0.9993)^{99}$$

$$y = (222.9965)(0.933)$$

$$y = 208.0557$$

4. The quadratic function seems to be the best fit for this model.

Basic Algebra Flexbook Solution Key

Chapter 11

Radicals and Geometry Connections; Data Analysis

Lesson 11.1

Graphs of Square Root Functions

1. In the definition of a square root function, $(x-h)$ must always be greater than or equal to zero because a negative number under a radical gives you an imaginary number. If the number under the radical were negative there would be no real solution and it would be impossible to graph or solve.

2. $f(x) = \sqrt{x}$

Domain: $x \geq 0$

Range: $y \geq 0$

3.

$$f(x) = \sqrt{x-2}$$

$$h = 2$$

$$k = 0$$

$$(h, k) = (2, 0)$$

4.

$$g(x) = \sqrt{x+4} + 6$$

$$h = -4$$

$$k = 6$$

$$(h, k) = (-4, 6)$$

5.

$$h(x) = \sqrt{x-1} - 1$$

$$h = 1$$

$$k = -1$$

$$(h, k) = (1, -1)$$

6.

$$y = \sqrt{x} + 3$$

$$h = 0$$

$$k = 3$$

$$(h, k) = (0, 3)$$

7.

$$f(x) = \sqrt{2x} + 4$$

$$h = 0$$

$$k = 4$$

$$(h, k) = (0, 4)$$

8.

$$y = \sqrt{x}$$

$$y = 2.5\sqrt{x}$$

$$y = -2.5\sqrt{x}$$

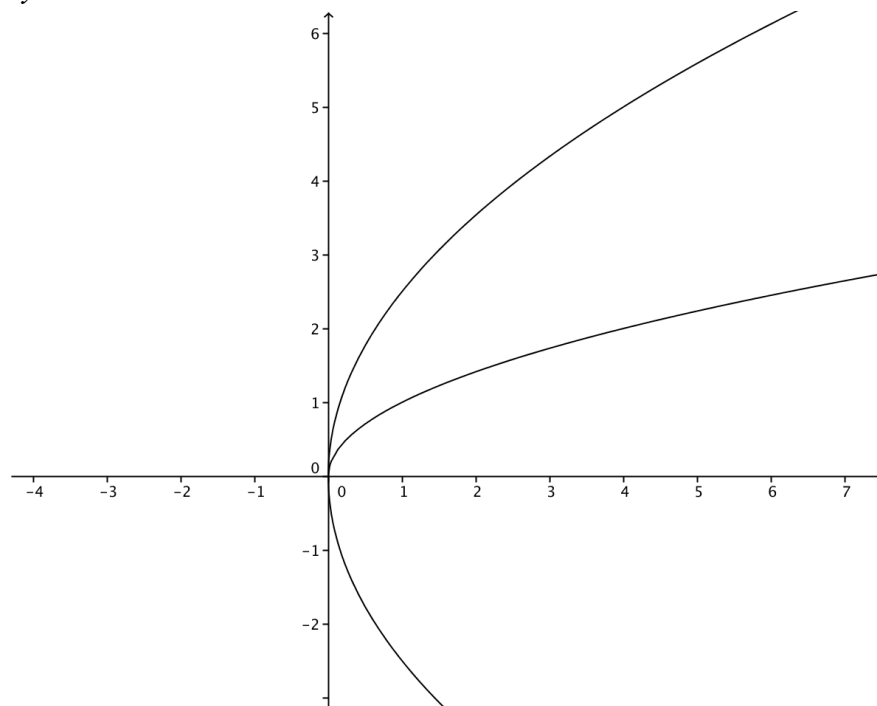

9.

$$y = \sqrt{x}$$

$$y = 0.3\sqrt{x}$$

$$y = 0.6\sqrt{x}$$

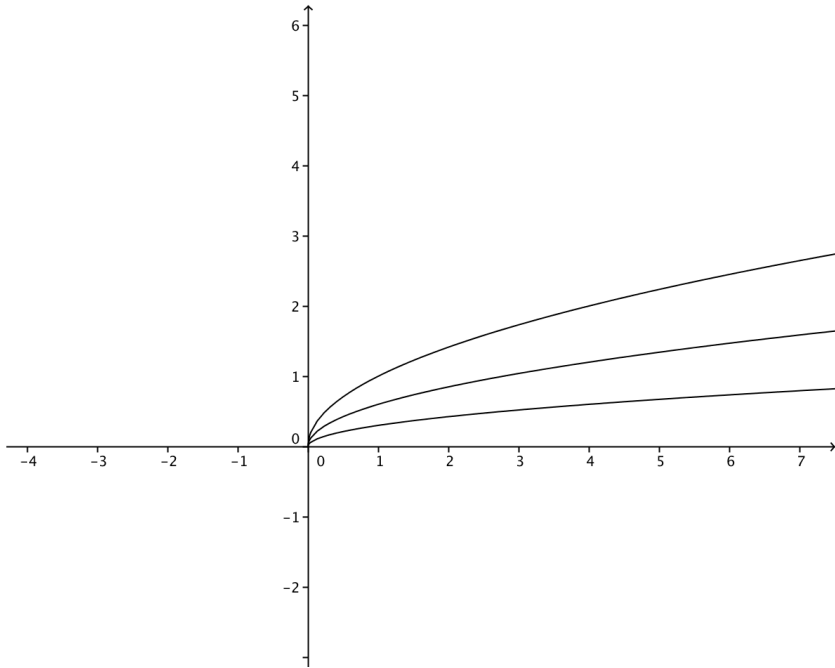

10.

$$y = \sqrt{x}$$

$$y = \sqrt{x-5}$$

$$y = \sqrt{x+5}$$

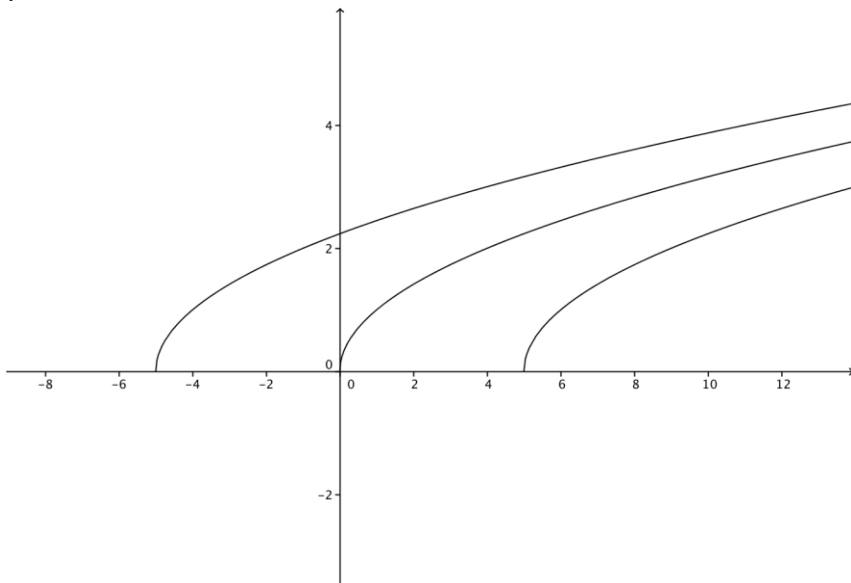

11.

$$y = \sqrt{x}$$

$$y = \sqrt{x} + 8$$

$$y = \sqrt{x} - 8$$

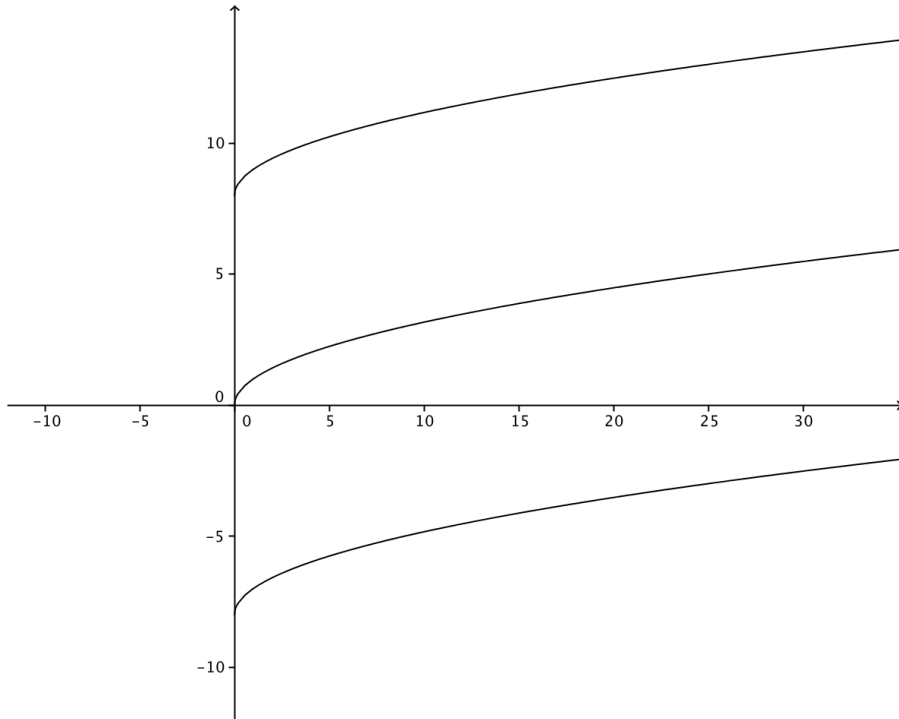

12. $y = \sqrt{2x-1}$

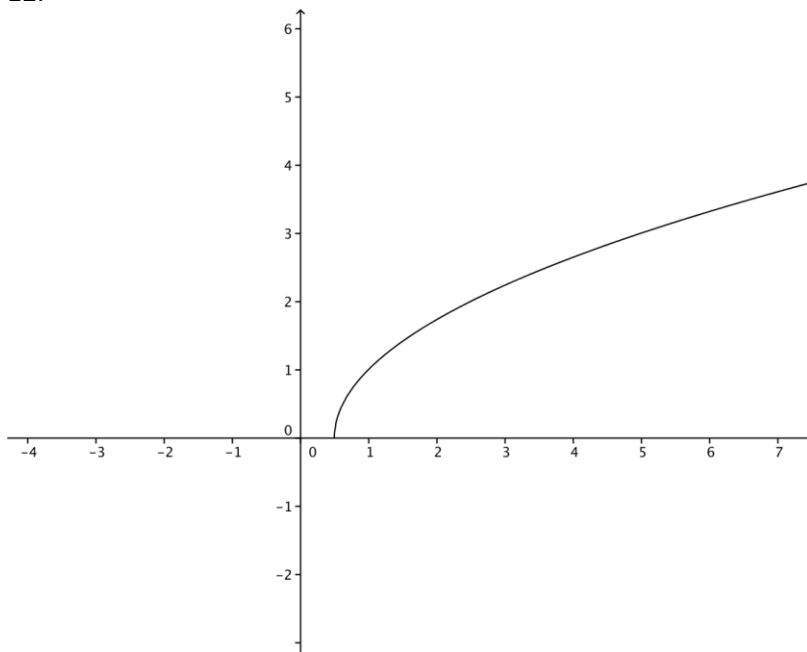

13. $y = \sqrt{4x+4}$

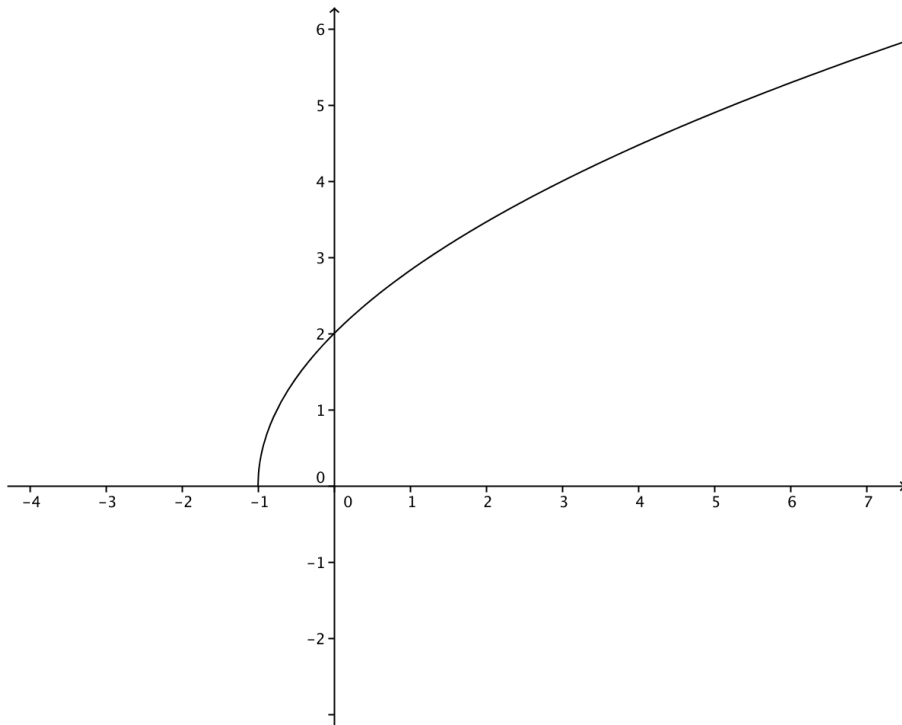

14. $y = \sqrt{5-x}$

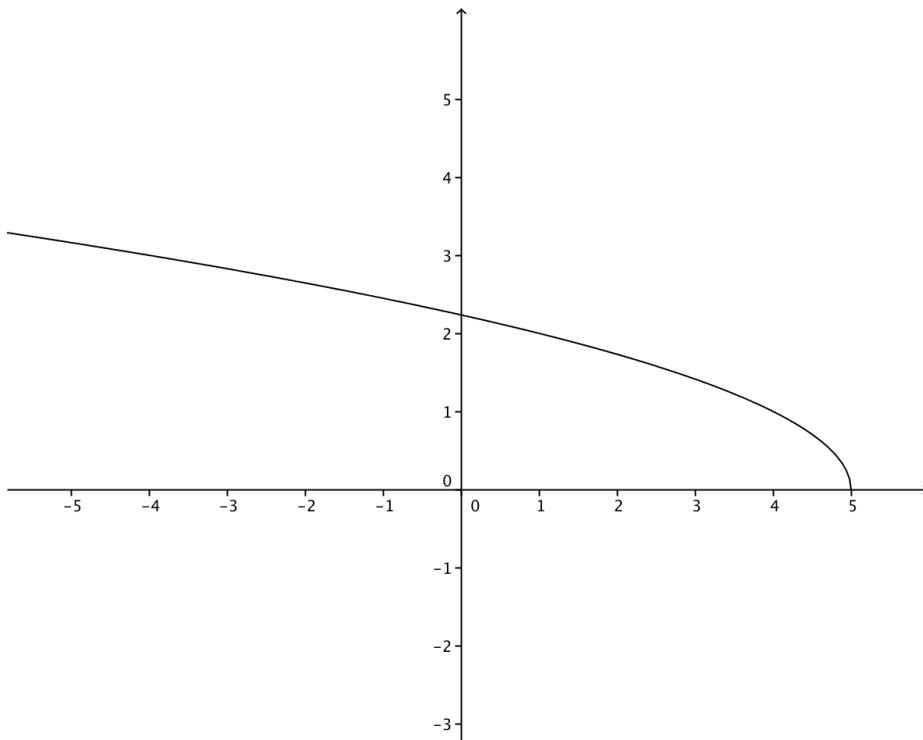

15. $y = 2\sqrt{x} + 5$

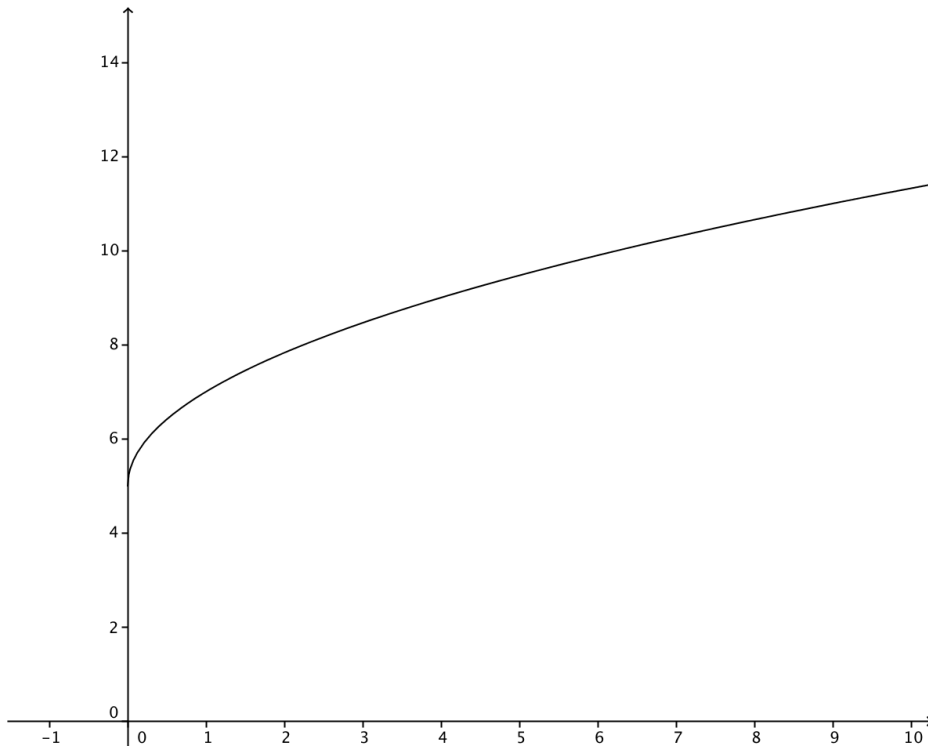

16. $y = 3 - \sqrt{x}$

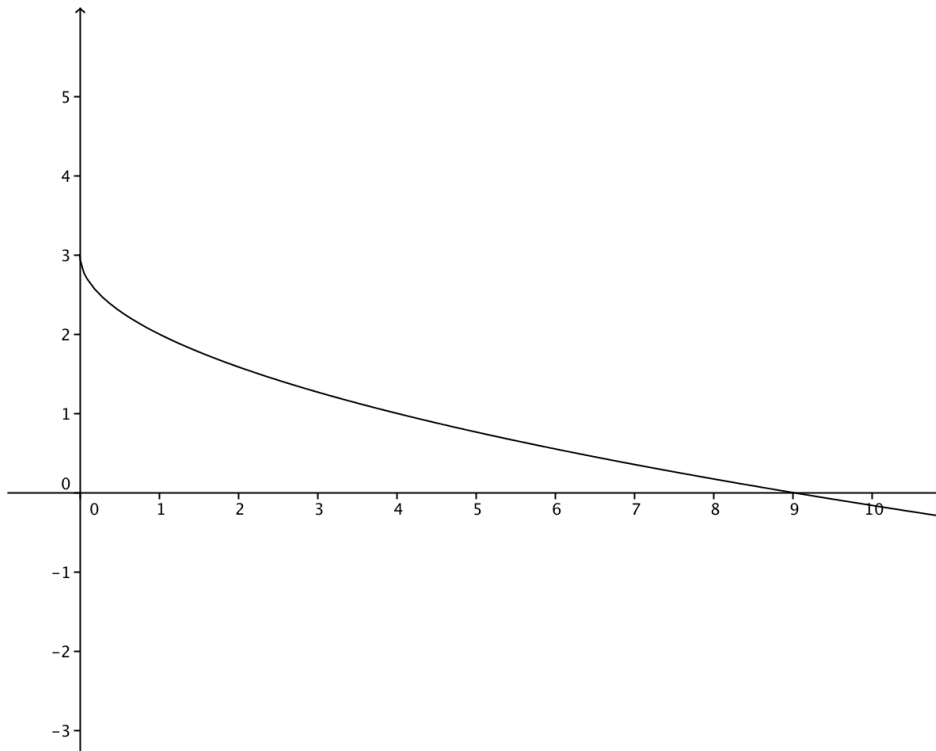

17. $y = 4 + 2\sqrt{x}$

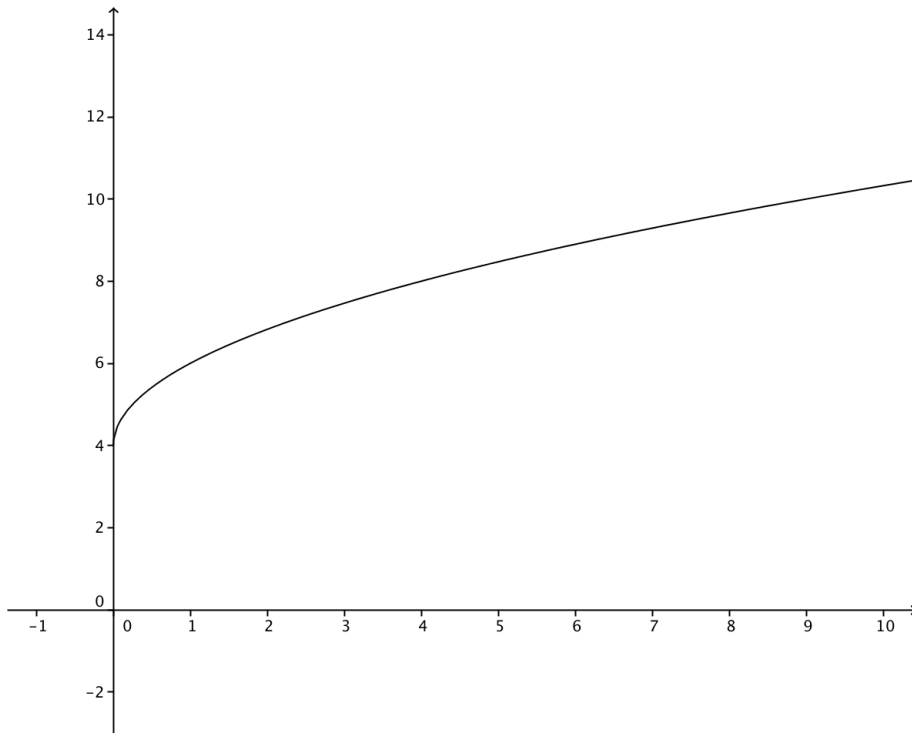

18. $y = 2\sqrt{2x+3} + 1$

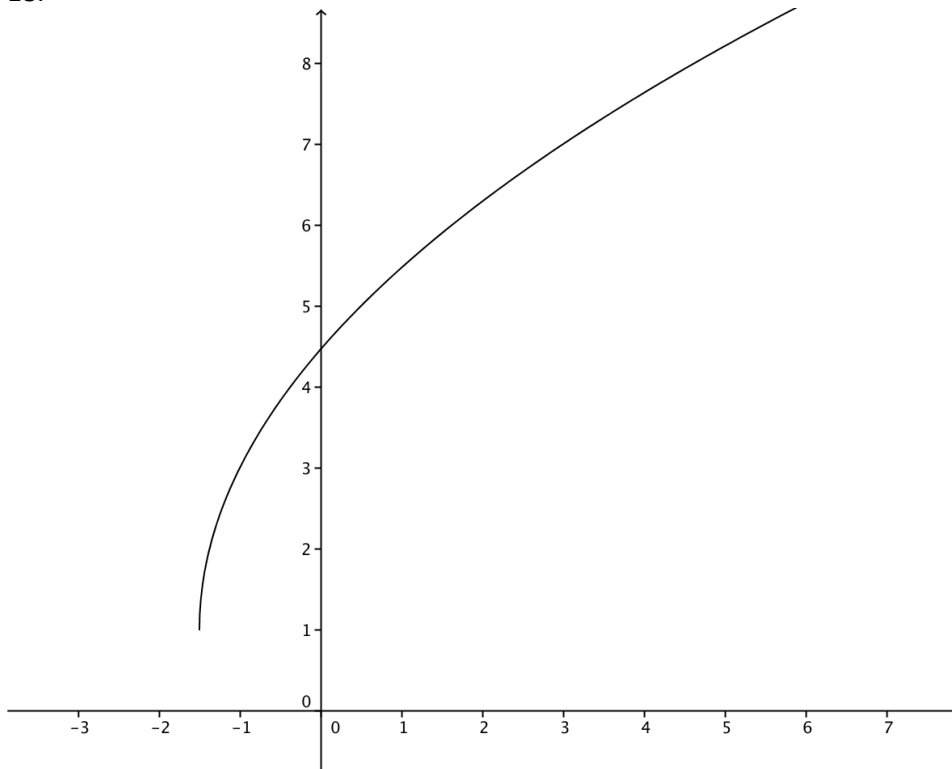

19. $y = 4 + 2\sqrt{2-x}$

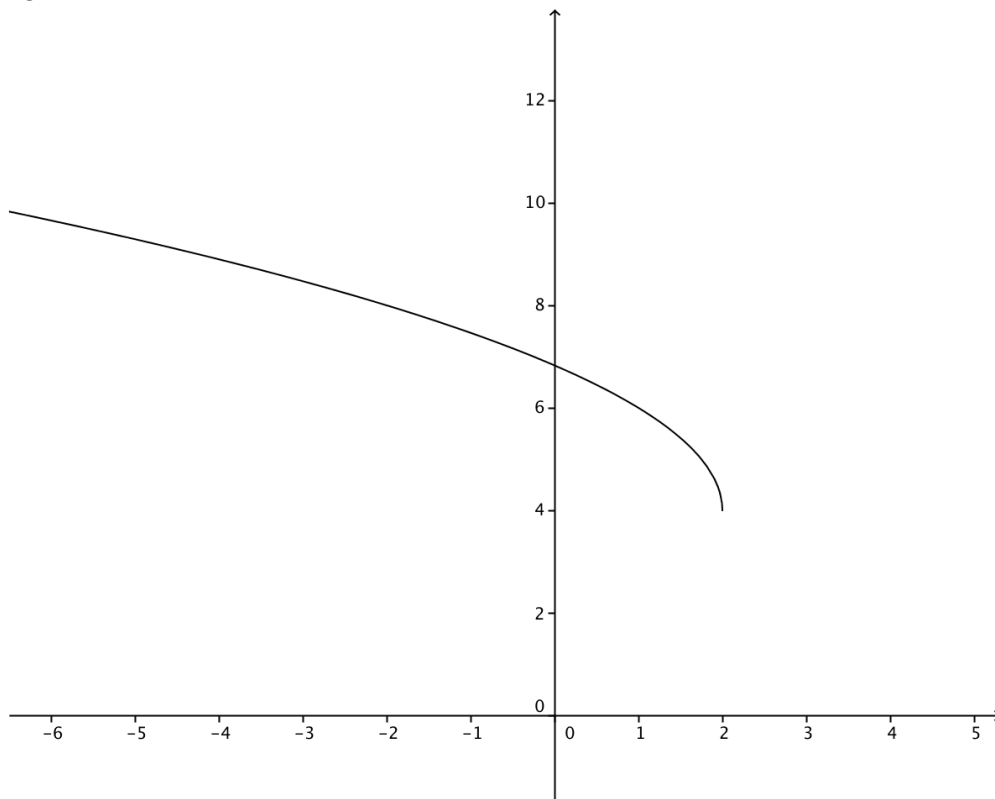

20. $y = \sqrt{x+1} - \sqrt{4x-5}$

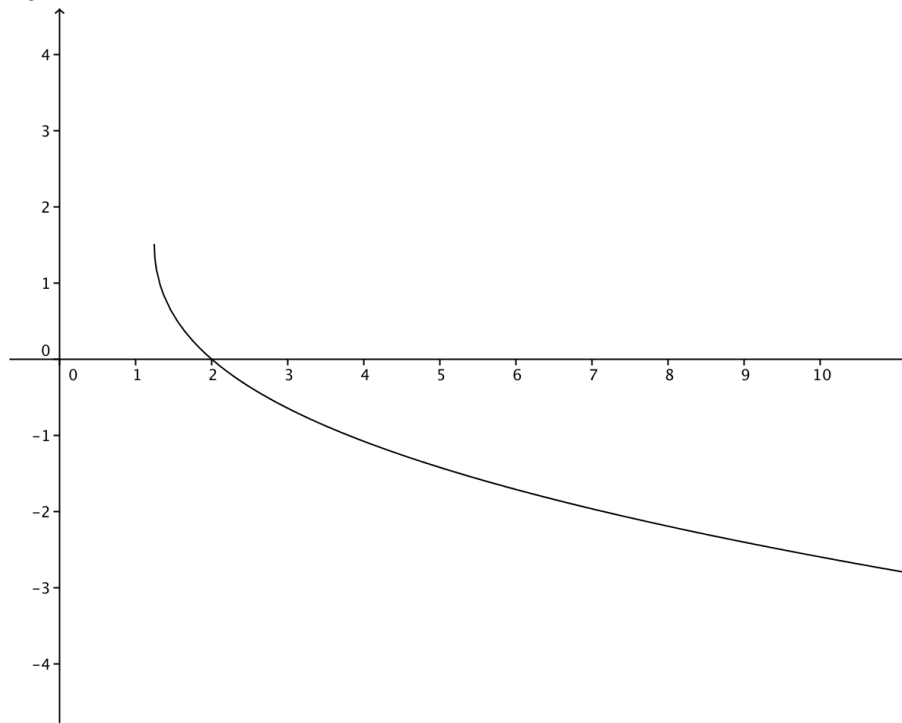

21.

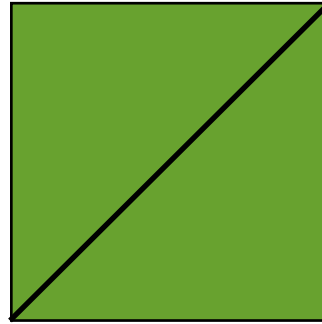
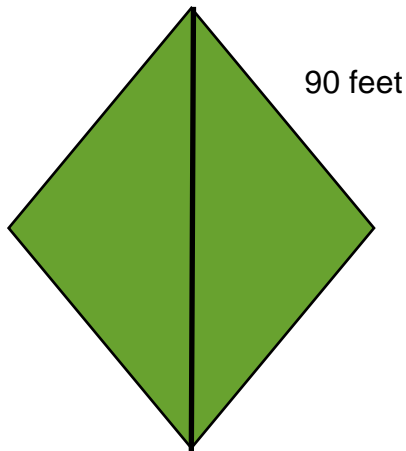

The diagonal walked by the catcher is the hypotenuse of a right triangle, so we can use pythagorean theorem.

$$a^2 + b^2 = c^2$$

$$90^2 + 90^2 = c^2$$

$$8100 + 8100 = c^2$$

$$16200 = c^2$$

$$\sqrt{16200} = \sqrt{c^2}$$

$$c = \sqrt{16200}$$

$$c \approx 127.2792$$

The distance run by the runner is $90 + 90 = 180$ feet.

The distance covered by the catcher is approximately 127.2792 feet.

The catcher goes $(180 - 127.2792 = 52.7208)$ approximately 53 feet less.

22.

$$T = 2\pi\sqrt{\frac{L}{g}}$$

$$T = 2\pi\sqrt{\frac{L}{32}}$$

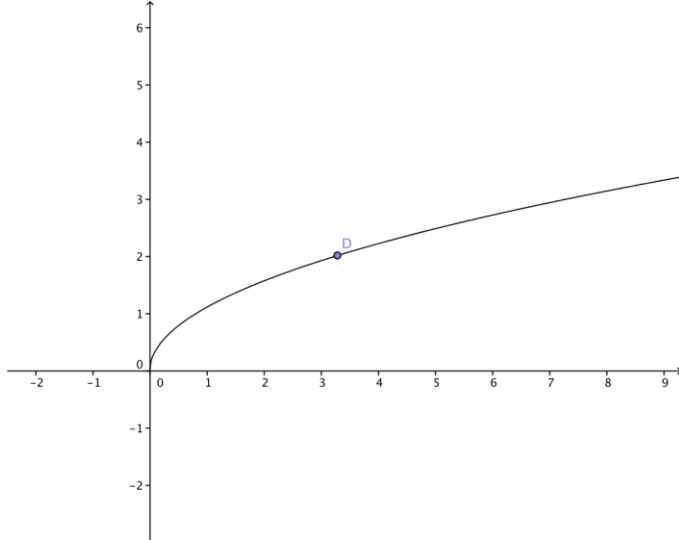

When $T=2$ then the length of the pendulum is 3.24ft

23.

$$T = 2\pi\sqrt{\frac{L}{g}}$$

$$T = 2\pi\sqrt{\frac{L}{1.6}}$$

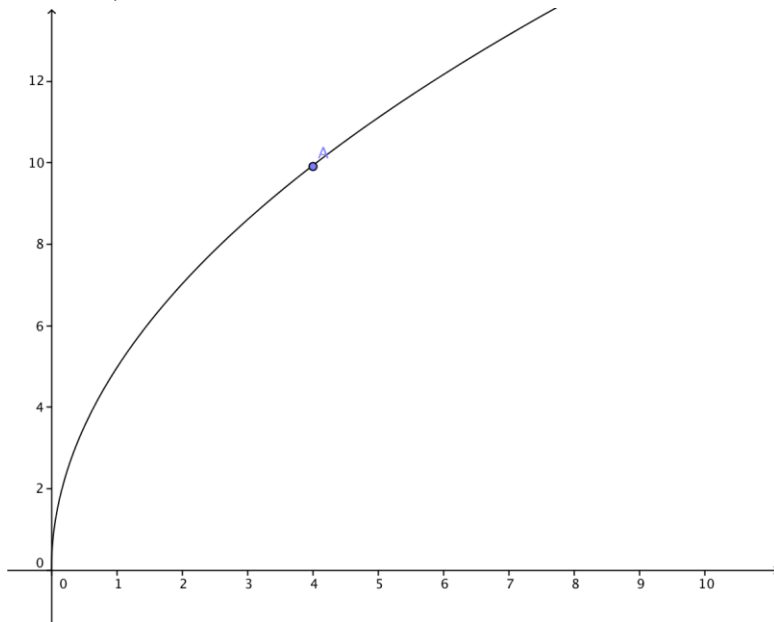

When $T=10$ then the length of the pendulum is 4.052 m

24.

$$T = 2\pi\sqrt{\frac{L}{g}}$$

$$T = 2\pi\sqrt{\frac{L}{3.69}}$$

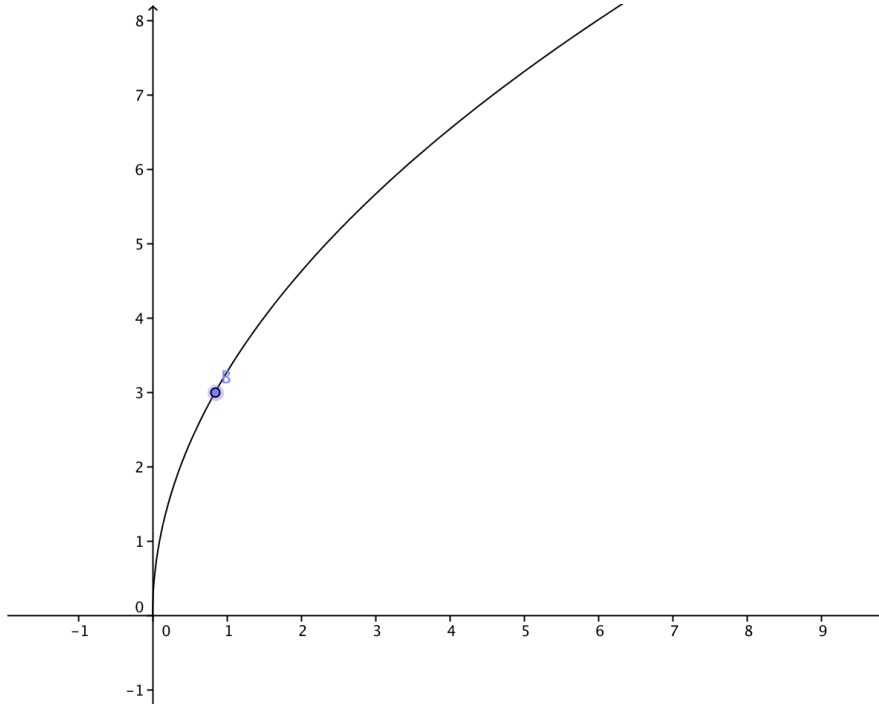

When $T=3$ then the length of the pendulum is 0.8412 m

25.

$$T = 2\pi\sqrt{\frac{L}{g}}$$

$$T = 2\pi\sqrt{\frac{L}{9.819}}(\text{Helsinki})$$

$$T = 2\pi\sqrt{\frac{L}{9.796}}(\text{LosAngeles})$$

$$T = 2\pi\sqrt{\frac{L}{9.779}}(\text{MexicoCity})$$

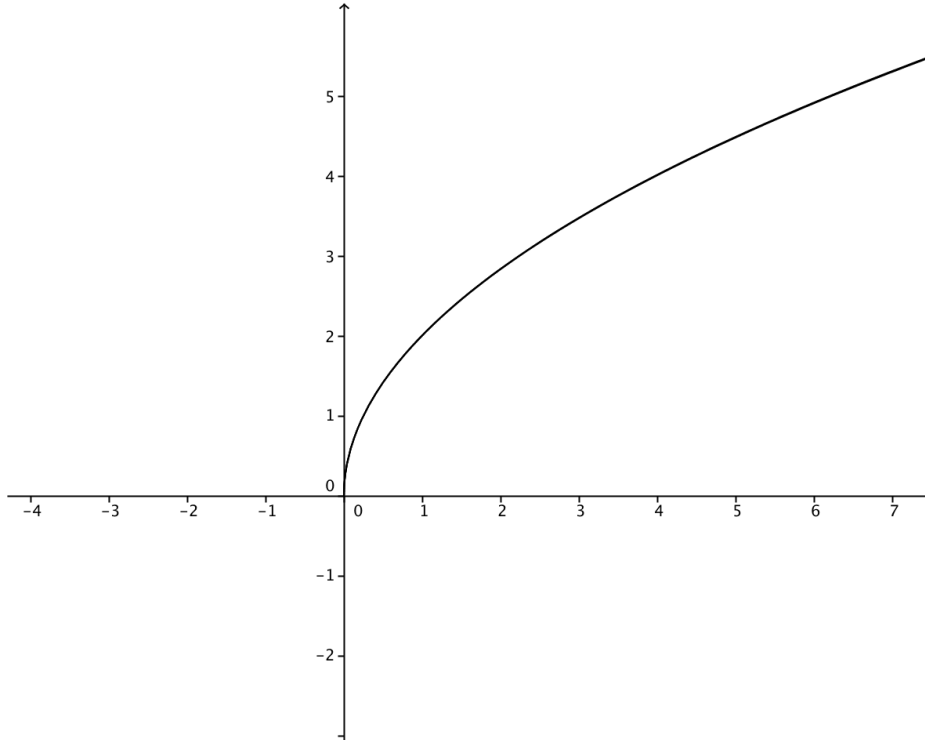

(The functions are so close they graph on top of on another.)

$$T = 2\pi\sqrt{\frac{L}{9.819}}(\text{Helsinki})$$

$$T = 2\pi\sqrt{\frac{L}{9.796}}(\text{LosAngeles})$$

$$T = 2\pi\sqrt{\frac{L}{9.779}}(\text{MexicoCity})$$

$$8 = 2(3.14)\sqrt{\frac{L}{9.819}}$$

$$8 = 2(3.14)\sqrt{\frac{L}{9.796}}$$

$$8 = 2(3.14)\sqrt{\frac{L}{9.779}}$$

$$8 = 6.28\sqrt{\frac{L}{9.819}}$$

$$8 = 6.28\sqrt{\frac{L}{9.796}}$$

$$8 = 6.28\sqrt{\frac{L}{9.779}}$$

$$1.2739 = \sqrt{\frac{L}{9.819}}$$

$$1.2739 = \sqrt{\frac{L}{9.796}}$$

$$1.2739 = \sqrt{\frac{L}{9.779}}$$

$$1.2739 = \sqrt{L} \div \sqrt{9.819}$$

$$1.2739 = \sqrt{L} \div \sqrt{9.796}$$

$$1.2739 = \sqrt{L} \div \sqrt{9.779}$$

$$1.2739 = \sqrt{L} \div 3.1335$$

$$1.2739 = \sqrt{L} \div 3.1299$$

$$1.2739 = \sqrt{L} \div 3.1271$$

$$3.9918 = \sqrt{L}$$

$$3.9872 = \sqrt{L}$$

$$3.9836 = \sqrt{L}$$

$$3.9918^2 = (\sqrt{L})^2$$

$$3.9872^2 = (\sqrt{L})^2$$

$$3.9836^2 = (\sqrt{L})^2$$

$$L = 15.9345$$

$$L = 15.8978$$

$$L = 15.8691$$

When the period is 8 seconds the length of the pendulum in Helsinki is 15.9345 meters.

When the period is 8 seconds the length of the pendulum in Los Angeles is 15.8978 meters.

When the period is 8 seconds the length of the pendulum in Mexico City is 15.8691 meters

26. $y = \sqrt{3x-2}$

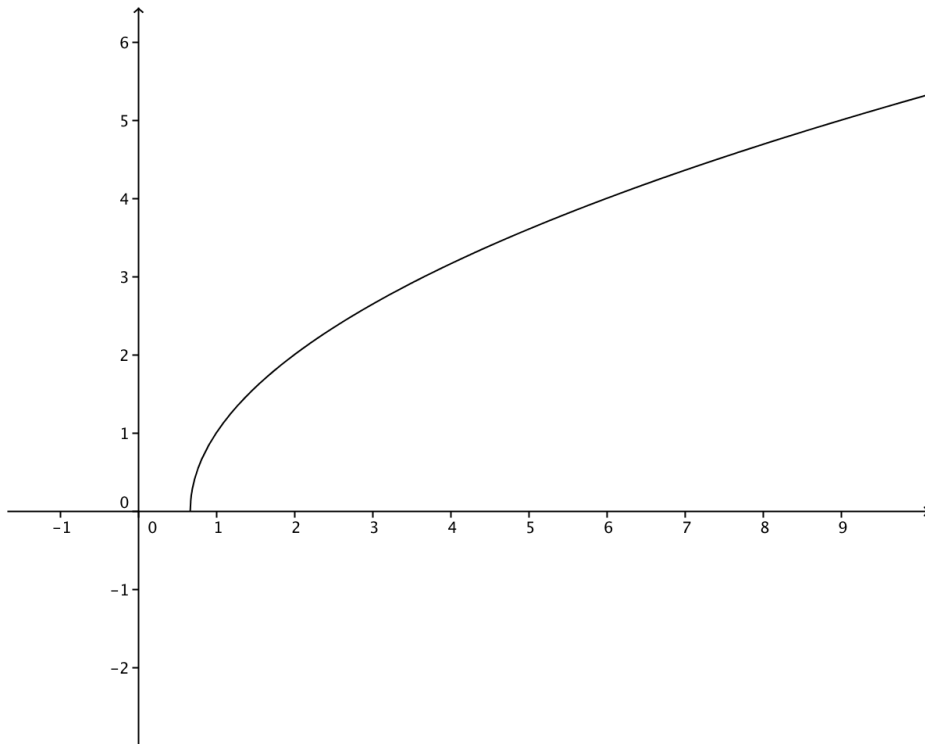

27. $y = 4 + \sqrt{2-x}$

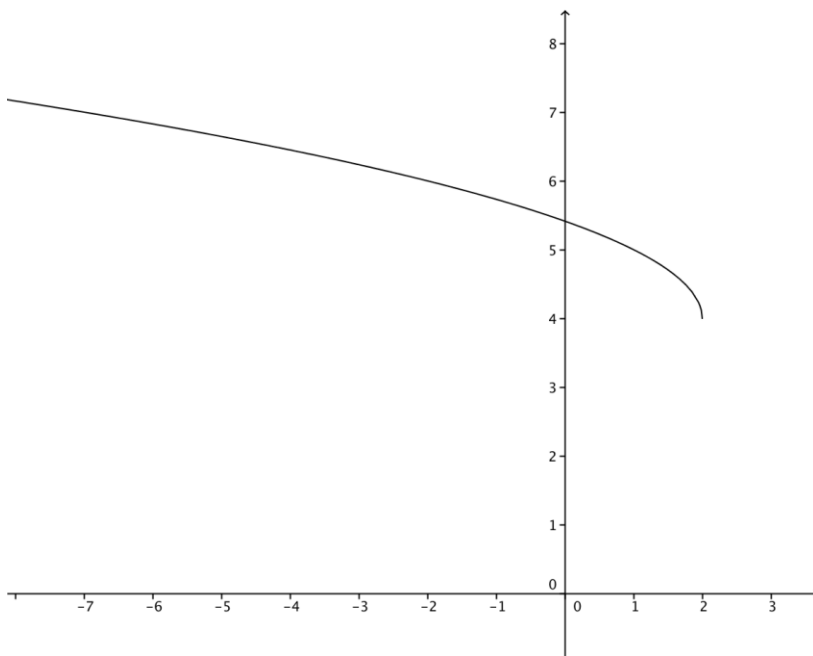

28. $y = \sqrt{x^2 - 9}$

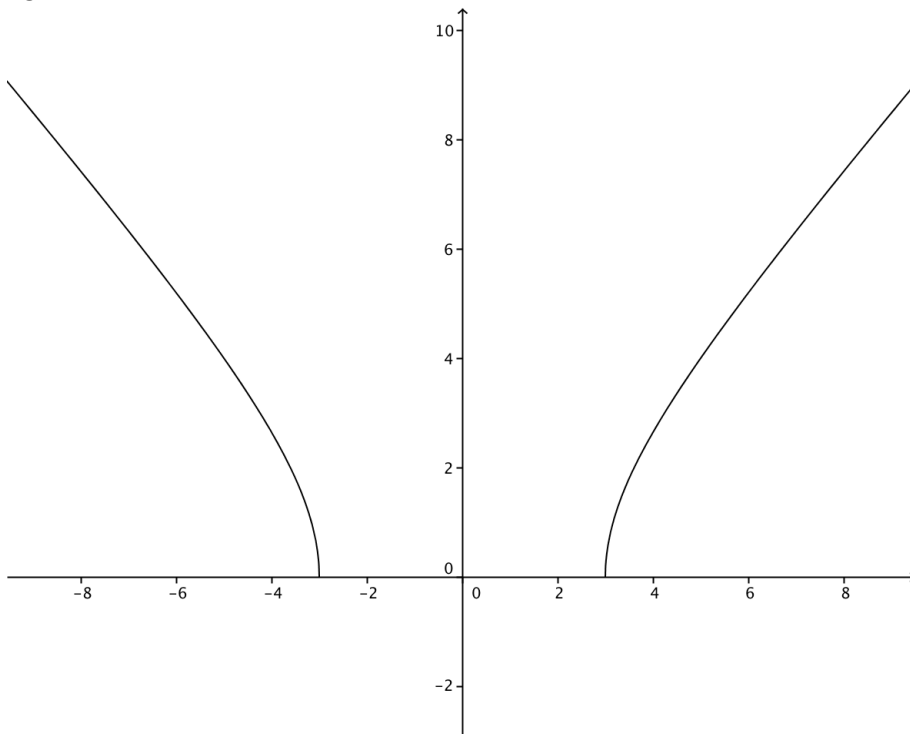

29. $y = \sqrt{x} - \sqrt{x+2}$

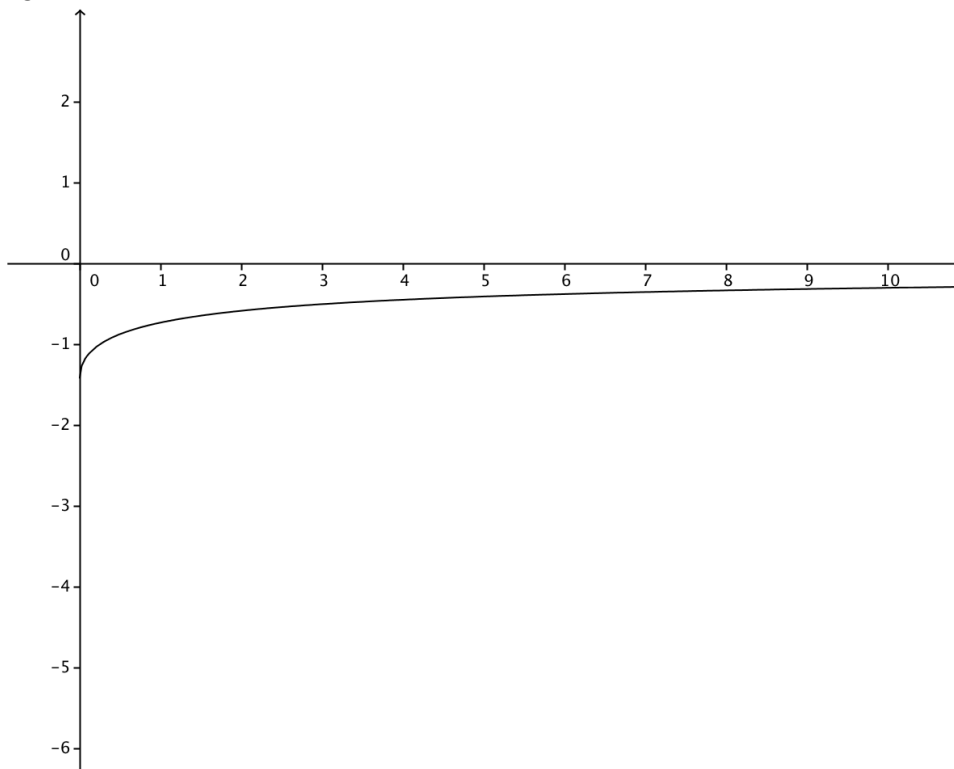

Mixed Review

30.

$$16 = 2x^2 - 3x + 4$$

$$0 = 2x^2 - 3x - 12$$

$$y = \frac{-b \pm \sqrt{b^2 - 4ac}}{2a}$$

$$y = \frac{-(-3) \pm \sqrt{(-3)^2 - 4(2)(-12)}}{2(2)}$$

$$y = \frac{3 \pm \sqrt{9 + 96}}{4}$$

$$y = \frac{3 \pm \sqrt{105}}{4}$$

$$y = \frac{3 + \sqrt{105}}{4} \approx \frac{3 + 10.247}{4} \approx \frac{13.247}{4} \approx 3.3118$$

$$y = \frac{3 - \sqrt{105}}{4} \approx \frac{3 - 10.247}{4} \approx \frac{-7.247}{4} \approx -1.8118$$

$$y \approx 3.3118, -1.8118$$

31.

$$y - y_1 = m(x - x_1)$$

$$y - 10 = 0.2(x - 1)$$

$$y - 10 = 0.2x - 0.2$$

$$y = 0.2x + 9.8$$

$$x + 5y = 16$$

32. $y = 5x - 3$

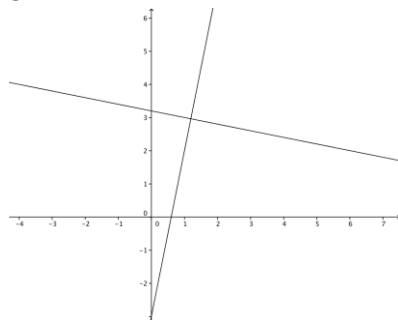

The lines are perpendicular.

33.

$$20x + 32y$$

$$(50, 0)$$

$$20(50) + 32(0) = 1000$$

$$(0, 60)$$

$$20(0) + 32(60) = 1920$$

$$(15, 30)$$

$$20(15) + 32(30) = 1260$$

The vertex (50,0) minimizes the expression $20x + 32y$

34. No the graph is not a function. Many of the x-values have more than one corresponding y-value.

35. The square root of 205 is between 14 and 15.

Lesson 11.2
Radical Expressions

1. $\sqrt[n]{-16}$ is undefined when n is even.

2. $\sqrt{169} = 13$

3. $\sqrt[4]{81} = 3$

4. $\sqrt[3]{-125} = -5$

5. $\sqrt[5]{1024} = 4$

6. $\sqrt[3]{14} = 14^{\frac{1}{3}}$

7. $\sqrt[4]{zw} = (zw)^{\frac{1}{4}}$

8. $\sqrt{a} = a^{\frac{1}{2}}$

9. $\sqrt[9]{y^3} = y^{\frac{3}{9}} = y^{\frac{1}{3}}$

10. $\sqrt{24} = \sqrt{4} * \sqrt{6} = 2\sqrt{6}$

11. $\sqrt{300} = \sqrt{3} * \sqrt{100} = 10\sqrt{3}$

12. $\sqrt[5]{96} = \sqrt[5]{32} * \sqrt[5]{3} = 2\sqrt[5]{3}$

13.

$$\sqrt{\frac{240}{567}} =$$

$$\sqrt{240} \div \sqrt{567} =$$

$$(\sqrt{16} * \sqrt{15}) \div (\sqrt{4} * \sqrt{141.75}) =$$

$$4\sqrt{15} \div 2\sqrt{141.75} =$$

$$\frac{2\sqrt{15}}{\sqrt{141.75}}$$

$$14. \sqrt[3]{500} = \sqrt[3]{125} * \sqrt[3]{4} = 5\sqrt[3]{4}$$

$$15. \sqrt[6]{64x^8} = \left(\sqrt[6]{64} * \sqrt[6]{x^6} * \sqrt[6]{x^2}\right) = 2x\sqrt[6]{x^2} = 2x\sqrt[3]{x}$$

$$16. \sqrt[3]{48a^3b^7} = \sqrt[3]{8} * \sqrt[3]{6} * a * b^{\frac{7}{3}} = 2\sqrt[3]{6} * a * b^2 * b^{\frac{1}{3}} = 2ab^2\sqrt[3]{6b}$$

17.

$$\begin{aligned} &\sqrt[3]{\frac{16x^5}{135y^4}} = \\ &\sqrt[3]{16x^5} \div \sqrt[3]{135y^4} = \\ &\left(\sqrt[3]{8} * \sqrt[3]{2} * x^{\frac{5}{3}}\right) \div \left(\sqrt[3]{27} * \sqrt[3]{5} * y^{\frac{4}{3}}\right) = \\ &\left(2 * \sqrt[3]{2} * x * x^{\frac{2}{3}}\right) \div \left(3 * \sqrt[3]{5} * y * y^{\frac{1}{3}}\right) = \\ &2x\sqrt[3]{2x^2} \div 3y\sqrt[3]{5y} = \frac{2x\sqrt[3]{2x^2}}{3y\sqrt[3]{5y}} \end{aligned}$$

18. FALSE

$$\begin{aligned} &\left(\sqrt[3]{5} * \sqrt[6]{6} = \sqrt[12]{30}\right) \\ &5^{\frac{1}{3}} * 6^{\frac{1}{6}} = 5^{\frac{2}{6}} * 6^{\frac{1}{6}} = 30^{\frac{13}{12}} = \sqrt[12]{30^{13}} \end{aligned}$$

19.

$$\begin{aligned} &3\sqrt{8} - 6\sqrt{32} = \\ &\left(3 * \sqrt{4} * \sqrt{2}\right) - \left(6 * \sqrt{16} * \sqrt{2}\right) = \\ &\left(3 * 2 * \sqrt{2}\right) - \left(6 * 4 * \sqrt{2}\right) = \\ &6\sqrt{2} - 24\sqrt{2} = \\ &-18\sqrt{2} \end{aligned}$$

20.

$$\begin{aligned} &\sqrt{180} + 6\sqrt{405} = \\ &\left(\sqrt{36} * \sqrt{5}\right) + \left(6 * \sqrt{81} * \sqrt{5}\right) = \\ &\left(6 * \sqrt{5}\right) + \left(6 * 9 * \sqrt{5}\right) = \\ &6\sqrt{5} + 54\sqrt{5} = \\ &60\sqrt{5} \end{aligned}$$

21.

$$\begin{aligned}\sqrt{6} - \sqrt{27} + 2\sqrt{54} + 3\sqrt{48} &= \\ (\sqrt{6}) - (\sqrt{9} * \sqrt{3}) + (2 * \sqrt{9} * \sqrt{6}) + (3 * \sqrt{4} * \sqrt{4} * \sqrt{3}) &= \\ (\sqrt{6}) - (3 * \sqrt{3}) + (2 * 3 * \sqrt{6}) + (3 * 2 * 2 * \sqrt{3}) &= \\ \sqrt{6} - 3\sqrt{3} + 6\sqrt{6} + 12\sqrt{3} &= \\ 7\sqrt{6} + 9\sqrt{3} &\end{aligned}$$

22.

$$\begin{aligned}\sqrt{8x^3} - 4x\sqrt{98x} &= \\ (\sqrt{4} * \sqrt{2} * \sqrt{x^2} * \sqrt{x}) - (4x * \sqrt{49} * \sqrt{2} * \sqrt{x}) &= \\ (2 * \sqrt{2} * x * \sqrt{x}) - (4x * 7 * \sqrt{2} * \sqrt{x}) &= \\ 2x\sqrt{2x} - 28x\sqrt{2x} &= \\ -26x\sqrt{2x} &\end{aligned}$$

23.

$$\begin{aligned}\sqrt{48a} + \sqrt{27a} &= \\ (\sqrt{16} * \sqrt{3} * \sqrt{a}) + (\sqrt{9} * \sqrt{3} * \sqrt{a}) &= \\ 4\sqrt{3a} + 3\sqrt{3a} &= \\ 7\sqrt{3a} &\end{aligned}$$

24.

$$\begin{aligned}\sqrt[3]{4x^3} + x\sqrt[3]{256} &= \\ (\sqrt[3]{4} * \sqrt[3]{x^3}) + (x * \sqrt[3]{64} * \sqrt[3]{4}) &= \\ x\sqrt[3]{4} + 4x\sqrt[3]{4} &= \\ 5x\sqrt[3]{4} &\end{aligned}$$

25. $\sqrt{6}(\sqrt{10} + \sqrt{8}) = \sqrt{60} + \sqrt{48} = (\sqrt{4} * \sqrt{15}) + (\sqrt{16} * \sqrt{3}) = 2\sqrt{15} + 4\sqrt{3}$

$$26. (\sqrt{a} - \sqrt{b})(\sqrt{a} + \sqrt{b}) = (\sqrt{a^2} + \sqrt{ab} - \sqrt{ab} - \sqrt{b^2}) = a - b$$

$$27. (2\sqrt{x} + 5)(2\sqrt{x} + 5) = (4\sqrt{x^2} + 10\sqrt{x} + 10\sqrt{x} + 25) = 4x + 20\sqrt{x} + 25$$

$$28. \frac{7}{\sqrt{15}} = \frac{7 * \sqrt{15}}{\sqrt{15} * \sqrt{15}} = \frac{7\sqrt{15}}{15}$$

$$29. \frac{9}{\sqrt{10}} = \frac{9 * \sqrt{10}}{\sqrt{10} * \sqrt{10}} = \frac{9\sqrt{10}}{10}$$

$$30. \frac{2x}{\sqrt{5x}} = \frac{2x * \sqrt{5x}}{\sqrt{5x} * \sqrt{5x}} = \frac{2x\sqrt{5x}}{5x}$$

$$31. \frac{\sqrt{5}}{\sqrt{3y}} = \frac{\sqrt{5} * \sqrt{3y}}{\sqrt{3y} * \sqrt{3y}} = \frac{\sqrt{15y}}{3y}$$

32.

$$V = \frac{4}{3}\pi R^3$$

$$950 = \frac{4}{3}\pi R^3$$

$$950 = \left(\frac{4}{3}\right)(3.14)R^3$$

$$950 = 4.1867R^3$$

$$227.8888 = R^3$$

$$\sqrt[3]{227.8888} = \sqrt[3]{R^3}$$

$$R \approx 6.1081$$

The radius of the balloon is approximately 6.1081.

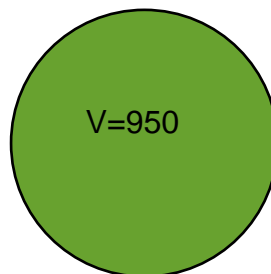

33.

$$A = (9 + 2W)(12 + 2W)$$

$$180 = (9 + 2W)(12 + 2W)$$

$$180 = 108 + 18W + 24W + 4W^2$$

$$72 = 42W + 4W^2$$

$$0 = 4W^2 + 42W - 72$$

$$y = \frac{-b \pm \sqrt{b^2 - 4ac}}{2a}$$

$$y = \frac{-42 \pm \sqrt{42^2 - 4(4)(-72)}}{2(4)}$$

$$y = \frac{-42 \pm \sqrt{1764 + 1152}}{8}$$

$$y = \frac{-42 \pm \sqrt{2916}}{8}$$

$$y = \frac{-42 + \sqrt{2916}}{8} = \frac{-42 + 54}{8} = \frac{12}{8} = 1.5$$

$$y = \frac{-42 - \sqrt{2916}}{8} = \frac{-42 - 54}{8} = \frac{-96}{8} = -12$$

$$y = 1.5$$

The width of the frame is 1.5 inches.

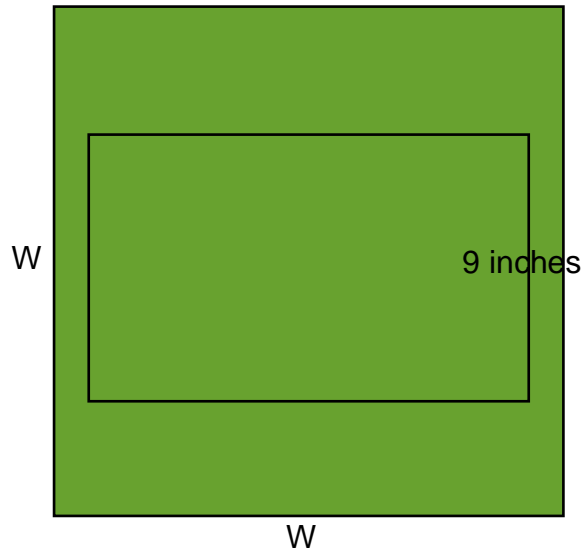

34.

$$V = \pi r^2 h$$

$$h = 4r^2$$

$$V = 355$$

$$355 = \pi r^2 (4r^2)$$

$$355 = 3.14r^2 (4r^2)$$

$$355 = 12.56r^4$$

$$28.2643 = r^4$$

$$\sqrt[4]{28.2643} = \sqrt[4]{r^4}$$

$$r = 2.3057$$

The radius of the base of the cylinder is approximately 2.3057 cm.

Mixed Review

35.

$$c - 15\% = 612.99$$

$$c - 0.15c = 612.99$$

$$.85c = 812.99$$

$$c = 956.4588$$

The original price of the item was \$956.46

36.

$$\frac{x+3}{6} = \frac{21}{x}$$

$$x(x+3) = 21 * 6$$

$$x^2 + 3x = 126$$

$$x^2 + 3x + 2.25 = 126 + 2.25$$

$$(x+1.5)^2 = 128.25$$

$$\sqrt{(x+1.5)^2} = \sqrt{128.25}$$

$$x+1.5 = \sqrt{128.25}$$

$$x = \sqrt{128.25} - 1.5$$

$$x \approx \pm 11.3248 - 1.5$$

$$x \approx 11.3248 - 1.5$$

$$x \approx 9.8248$$

$$x \approx -11.3248 - 1.5$$

$$x \approx -12.8248$$

$$x \approx 9.8248, -12.8248$$

37.

$$m = \frac{y_2 - y_1}{x_2 - x_1}$$

$$m = \frac{7.25 - 3.35}{2009 - 1989}$$

$$m = \frac{3.9}{20} = 0.195$$

The average rate of change is approximately \$0.20 per year.

38.

$$y = a(x - h)^2 + k$$

$$y = 2(x + 1)^2 + 4$$

$$a = 2$$

$$h = -1$$

$$k = 4$$

Vertex = (-1,4)

The vertex is a minimum.

39.

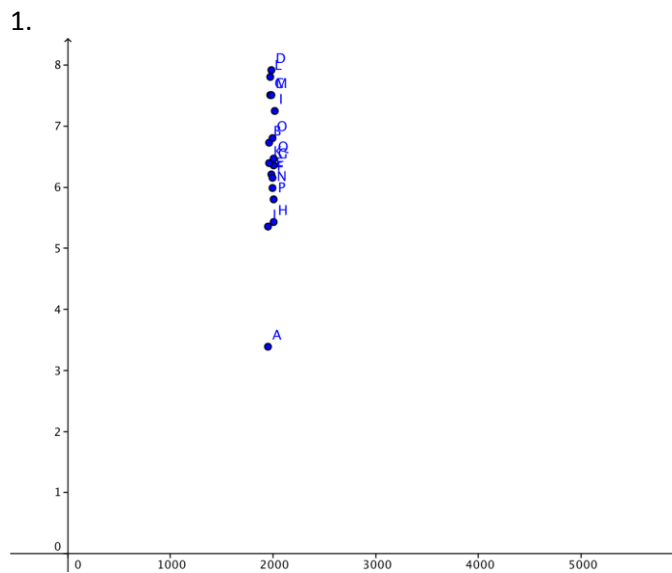

2. The best model for this data is linear.

$$y = mx + b$$

$$m = 0.0105$$

$$b = 5.5606$$

$$y = 0.0105x + 5.5606$$

$$x = 1999 = 99$$

$$y = 0.0105(99) + 5.5606$$

$$y = 1.0395 + 5.5606$$

3. $y = 6.6001$

Using the model of best fit the minimum wage (adj. for inflation) in 1999 would be \$6.60

4. My prediction was only \$0.2 off the EPI data.

$$m = \frac{y_2 - y_1}{x_2 - x_1}$$

$$m = \frac{7.52 - 6.40}{1965 - 1960} = \frac{1.12}{5} = 0.224$$

$$y - y_1 = m(x - x_1)$$

$$y - 6.40 = 0.224(x - 1960)$$

$$y - 6.40 = 0.224x - 439.04$$

$$y = 0.224x - 432.64$$

$$x = 1962$$

$$y = 0.224(1962) - 432.64$$

$$5. y = 6.848$$

Using interpolation, the minimum wage in 1962 would be approximately \$6.85

Lesson 11.3
Radical Equations

1.

$$\sqrt{x+2} - 2 = 0$$

$$\sqrt{x+2} = 2$$

$$(\sqrt{x+2})^2 = 2^2$$

$$x+2 = 4$$

$$x = 2$$

$$\sqrt{2+2} - 2 = 0$$

$$\sqrt{4} - 2 = 0$$

$$2 - 2 = 0$$

$$0 = 0$$

2.

$$\sqrt{3x-1} = 5$$

$$(\sqrt{3x-1})^2 = 5^2$$

$$3x-1 = 25$$

$$3x = 26$$

$$x = \frac{26}{3}$$

$$x \approx 8.6667$$

$$\sqrt{3\left(\frac{26}{3}\right)-1} = 5$$

$$\sqrt{26-1} = 5$$

$$\sqrt{25} = 5$$

$$5 = 5$$

3.

$$2\sqrt{4-3x} + 3 = 0$$

$$2\sqrt{4-3x} = -3$$

$$\sqrt{4-3x} = -1.5$$

$$(\sqrt{4-3x})^2 = (-1.5)^2$$

$$4-3x = 2.25$$

$$-3x = -1.75$$

$$x = 0.5833$$

$$2\sqrt{4-3(0.5833)} + 3 = 0$$

$$2\sqrt{4-1.7499} + 3 = 0$$

$$2\sqrt{2.2501} + 3 = 0$$

$$2(1.5) + 3 = 0$$

$$3 + 3 = 0$$

$$6 \neq 0$$

This is an extraneous solution. The equation has no real roots.

4.

$$\sqrt[3]{x-3} = 1$$

$$(\sqrt[3]{x-3})^3 = 1^3$$

$$x-3 = 1$$

$$x = 4$$

$$\sqrt[3]{4-3} = 1$$

$$\sqrt[3]{1} = 1$$

$$1 = 1$$

5.

$$\sqrt[4]{x^2 - 9} = 2$$

$$\left(\sqrt[4]{x^2 - 9}\right)^4 = 2^4$$

$$x^2 - 9 = 16$$

$$x^2 = 25$$

$$x = 5$$

$$\sqrt[4]{5^2 - 9} = 2$$

$$\sqrt[4]{25 - 9} = 2$$

$$\sqrt[4]{16} = 2$$

$$2 = 2$$

6.

$$\sqrt[3]{-2 - 5x} + 3 = 0$$

$$\sqrt[3]{-2 - 5x} = -3$$

$$\left(\sqrt[3]{-2 - 5x}\right)^3 = (-3)^3$$

$$-2 - 5x = -27$$

$$-5x = -25$$

$$x = 5$$

$$\sqrt[3]{-2 - 5(5)} + 3 = 0$$

$$\sqrt[3]{-2 - 25} + 3 = 0$$

$$\sqrt[3]{-27} + 3 = 0$$

$$-3 + 3 = 0$$

$$0 = 0$$

7.

$$\sqrt{x} = x - 6$$

$$(\sqrt{x})^2 = (x - 6)^2$$

$$x = x^2 - 12x + 36$$

$$0 = x^2 - 13x + 36$$

$$y = \frac{-b \pm \sqrt{b^2 - 4ac}}{2a}$$

$$y = \frac{-(-13) \pm \sqrt{(-13)^2 - 4(1)(36)}}{2(1)}$$

$$y = \frac{13 \pm \sqrt{169 - 144}}{2}$$

$$y = \frac{13 \pm \sqrt{25}}{2}$$

$$y = \frac{13 + \sqrt{25}}{2} = \frac{13 + 5}{2} = \frac{18}{2} = 9$$

$$y = \frac{13 - \sqrt{25}}{2} = \frac{13 - 5}{2} = \frac{8}{2} = 4$$

$$\sqrt{9} = 9 - 6$$

$$3 = 3$$

$$\sqrt{4} = 9 - 4$$

$$2 \neq 5$$

There is one real solution ($x=9$) and one extraneous solution ($x=4$).

8.

$$\sqrt{x^2 - 5x} - 6 = 0$$

$$\sqrt{x^2 - 5x} = 6$$

$$\left(\sqrt{x^2 - 5x}\right)^2 = 6^2$$

$$x^2 - 5x = 36$$

$$x^2 - 5x + 6.25 = 36 + 6.25$$

$$(x - 2.5)^2 = 42.25$$

$$\sqrt{(x - 2.5)^2} = \sqrt{42.25}$$

$$x - 2.5 = \pm 6.5$$

$$x = \pm 6.5 + 2.5$$

$$x = 6.5 + 2.5$$

$$x = 9$$

$$x = -6.5 + 2.5$$

$$x = -4$$

$$\sqrt{9^2 - 5(9)} - 6 = 0$$

$$\sqrt{81 - 45} - 6 = 0$$

$$\sqrt{36} - 6 = 0$$

$$6 - 6 = 0$$

$$\sqrt{(-4)^2 - 5(-4)} - 6 = 0$$

$$\sqrt{16 + 20} - 6 = 0$$

$$\sqrt{36} - 6 = 0$$

$$6 - 6 = 0$$

$$0 = 0$$

There are two real solutions, $x=9$ and $x=-4$

9.

$$\sqrt{(x+1)(x-3)} = x$$

$$\left(\sqrt{(x+1)(x-3)}\right)^2 = x^2$$

$$(x+1)(x-3) = x^2$$

$$x^2 - 2x - 3 = x^2$$

$$-2x - 3 = 0$$

$$-2x = 3$$

$$x = -1.5$$

$$\sqrt{(-1.5+1)(-1.5-3)} = -1.5$$

$$\sqrt{(-0.5)(-4.5)} = -1.5$$

$$\sqrt{2.25} = -1.5$$

$$-1.5 = -1.5$$

10.

$$\sqrt{x+6} = x+4$$

$$\left(\sqrt{x+6}\right)^2 = (x+4)^2$$

$$x+6 = x^2 + 8x + 16$$

$$6 = x^2 + 7x + 16$$

$$0 = x^2 + 7x + 10$$

$$(x+5)(x+2) = 0$$

$$x+5 = 0$$

$$x = -5$$

$$x+2 = 0$$

$$x = -2$$

$$\sqrt{-5+6} = -5+4$$

$$\sqrt{1} = -1$$

$$-1 = -1$$

$$\sqrt{-2+6} = -2+4$$

$$\sqrt{4} = 2$$

$$2 = 2$$

There are two real solutions, $x=-5$ and $x=-2$

11.

$$\sqrt{x} = \sqrt{x-9} + 1$$

$$\sqrt{x} - 1 = \sqrt{x-9}$$

$$(\sqrt{x} - 1)^2 = (\sqrt{x-9})^2$$

$$(\sqrt{x})^2 - 1\sqrt{x} - 1\sqrt{x} + 1 = x - 9$$

$$x - 2\sqrt{x} + 1 = x - 9$$

$$-2\sqrt{x} = -10$$

$$\sqrt{x} = 5$$

$$x = 25$$

$$\sqrt{25} = \sqrt{25-9} + 1$$

$$5 = \sqrt{16} + 1$$

$$5 = 4 + 1$$

$$5 = 5$$

12.

$$\sqrt{3x+4} = -6$$

$$(\sqrt{3x+4})^2 = (-6)^2$$

$$3x + 4 = 36$$

$$3x = 32$$

$$x = \frac{32}{3}$$

$$x \approx 10.6667$$

$$\sqrt{3\left(\frac{32}{3}\right) + 4} = -6$$

$$\sqrt{32 + 4} = -6$$

$$\sqrt{36} = -6$$

$$-6 = -6$$

13.

$$\sqrt{10-5x} + \sqrt{1-x} = 7$$

$$\sqrt{10-5x} = -\sqrt{1-x} + 7$$

$$(\sqrt{10-5x})^2 = (-\sqrt{1-x} + 7)^2$$

$$10-5x = (-\sqrt{1-x})^2 - 7\sqrt{1-x} - 7\sqrt{1-x} + 49$$

$$10-5x = 1-x-14\sqrt{1-x}+49$$

$$10-5x = 50-x-14\sqrt{1-x}$$

$$-4x = 40-14\sqrt{1-x}$$

$$-4x-40 = -14\sqrt{1-x}$$

$$\frac{-4x-40}{-14} = \sqrt{1-x}$$

$$\left(\frac{-4x-40}{-14}\right)^2 = (\sqrt{1-x})^2$$

$$\frac{16x^2+1600}{196} = 1-x$$

$$16x^2+1600 = 196(1-x)$$

$$16x^2+1600 = -196x+196$$

$$16x^2-196x+1404 = 0$$

$$16x^2-196x = -1404$$

$$16(x^2-12.25x) = -1404$$

$$16(x^2-12.25x+37.5156) = -1404+37.5156(16)$$

$$16(x-6.125)^2 = -803.7504$$

$$(x-6.125)^2 = -50.2344$$

$$\sqrt{(x-6.125)^2} = \sqrt{-50.2344}$$

$$x-6.125 = \sqrt{-50.2344}$$

$$x = \sqrt{-50.2344} + 6.125$$

The equation has no real roots.

14.

$$\sqrt{2x-2} - 2\sqrt{x} + 2 = 0$$

$$\sqrt{2x-2} = 2\sqrt{x} - 2$$

$$(\sqrt{2x-2})^2 = (2\sqrt{x} - 2)^2$$

$$2x - 2 = 4x - 4\sqrt{x} - 4\sqrt{x} + 4$$

$$2x - 2 = 4x - 8\sqrt{x} + 4$$

$$-6 = 2x - 8\sqrt{x}$$

$$-2x - 6 = -8\sqrt{x}$$

$$\frac{-2x - 6}{-8} = \sqrt{x}$$

$$\left(\frac{-2x - 6}{-8}\right)^2 = (\sqrt{x})^2$$

$$\frac{4x^2 + 36}{64} = x$$

$$4x^2 + 36 = 36x$$

$$4x^2 - 36x + 36 = 0$$

$$y = \frac{-b \pm \sqrt{b^2 - 4ac}}{2a}$$

$$y = \frac{-(-36) \pm \sqrt{(-36)^2 - 4(4)(36)}}{2(4)}$$

$$y = \frac{36 \pm \sqrt{1296 - 576}}{8}$$

$$y = \frac{36 \pm \sqrt{720}}{8}$$

$$y = \frac{36 + \sqrt{720}}{8} \approx \frac{36 + 26.8328}{8} \approx \frac{62.8328}{8} \approx 7.8541$$

$$y = \frac{36 - \sqrt{720}}{8} \approx \frac{36 - 26.8328}{8} \approx \frac{9.1672}{8} \approx 1.1459$$

$$\sqrt{2(7.8541) - 2} - 2\sqrt{7.8541} + 2 \approx 0$$

$$3.7025 - 5.605 + 2 \approx 0$$

$$0 = 0$$

$$\sqrt{2(1.1459) - 2} - 2\sqrt{1.1459} + 2 \approx 0$$

$$0.5402 - 2.1409 + 2 \approx 0$$

$$.3992 \neq 0$$

This equation has one real root (x is approximately 7.8541) and one extraneous solution.

15.

$$\sqrt{2x+5} - 3\sqrt{2x-3} = \sqrt{2-x}$$

$$\left(\sqrt{2x+5} - 3\sqrt{2x-3}\right)^2 = \left(\sqrt{2-x}\right)^2$$

$$(2x+5) - 3^2(2x-3) = 2-x$$

$$2x+5+9(2x-3) = 2-x$$

$$2x+5+18x-27 = 2-x$$

$$20x-22 = 2-x$$

$$21x = 24$$

$$x = \frac{24}{21}$$

$$x \approx 1.1429$$

$$\sqrt{2(1.1429)+5} - 3\sqrt{2(1.1429)-3} = \sqrt{2-(1.1429)}$$

$$\sqrt{2.2858+5} - 3\sqrt{2.2858-3} = \sqrt{0.8571}$$

$$\sqrt{7.2858} - 3\sqrt{-0.7142} = \sqrt{0.8571}$$

This is an extraneous solution.

16.

$$3\sqrt{x} - 9 = \sqrt{2x - 14}$$

$$(3\sqrt{x} - 9)^2 = (\sqrt{2x - 14})^2$$

$$9x - 27\sqrt{x} - 27\sqrt{x} + 81 = 2x - 14$$

$$7x - 54\sqrt{x} + 95 = 0$$

$$7x + 95 = 54\sqrt{x}$$

$$\frac{7x + 95}{54} = \sqrt{x}$$

$$\left(\frac{7x + 95}{54}\right)^2 = (\sqrt{x})^2$$

$$\frac{49x^2 + 9025}{2916} = x$$

$$49x^2 + 9025 = 2916x$$

$$49x^2 - 2916x + 9025 = 0$$

$$y = \frac{-b \pm \sqrt{b^2 - 4ac}}{2a}$$

$$y = \frac{-(-2916) \pm \sqrt{(-2916)^2 - 4(49)(9025)}}{2(9025)}$$

$$y = \frac{2916 \pm \sqrt{8503056 - 1768900}}{18050}$$

$$y = \frac{2916 \pm \sqrt{6734156}}{18050}$$

$$y = \frac{2916 + \sqrt{6734156}}{18050} \approx \frac{2916 + 2595.0252}{18050} \approx \frac{5511.0252}{18050} \approx 0.3053$$

$$y = \frac{2916 - \sqrt{6734156}}{18050} \approx \frac{2916 - 2595.0252}{18050} \approx \frac{320.9748}{18050} \approx 0.01778$$

$$3\sqrt{0.3053} - 9 = \sqrt{2(0.3053) - 14}$$

$$-7.3424 \neq \sqrt{-13.3894}$$

$$3\sqrt{0.01778} - 9 = \sqrt{2(0.01778) - 14}$$

$$-8.6 \neq \sqrt{-13.9644}$$

These are extraneous solutions. The equation has no real roots.

17.

$$A = \frac{1}{2}bh$$

$$A = \frac{1}{2}b(2b)$$

$$24 = \frac{1}{2}b(2b)$$

$$24 = \frac{b}{2}(2b)$$

$$24 = \frac{2b^2}{2}$$

$$24 = b^2$$

$$b = \sqrt{24}$$

$$b = 4.899$$

$$24 = \frac{1}{2}(4.899)(2 * 4.899)$$

$$24 = 2.4495(9.798)$$

$$24 = 24$$

The base of the triangle is 4.899 in and the height of the triangle is 9.798 in

18.

$$V = \frac{A(h)}{3}$$

$$1600 = \frac{A(10)}{3}$$

$$4800 = A(10)$$

$$480 = A$$

The area of the base is 480 meters squared.

19.

$$V = \pi r^2 h$$

$$245 = \left(\frac{22}{7}\right)\left(\frac{1}{2}d\right)^2\left(\frac{1}{3}d\right)$$

$$245 = \left(\frac{22}{7}\right)\left(\frac{1}{4}d^2\right)\left(\frac{1}{3}d\right)$$

$$245 = \left(\frac{22}{7}\right)\left(\frac{1}{12}d^3\right)$$

$$245 = \frac{22}{84}d^3$$

$$\frac{20580}{22} = d^3$$

$$\sqrt[3]{\frac{20580}{22}} = \sqrt[3]{d^3}$$

$$d = \sqrt[3]{\frac{20580}{22}}$$

$$d \approx 9.78$$

$$h \approx 3.26$$

$$h = 3.26 + 2 = 5.26$$

$$r = 9.78 \div 2 = 4.89$$

$$V = \pi r^2 h$$

$$V = (3.14)(4.89^2)(5.26)$$

$$V = (3.14)(21.0681)(5.26)$$

$$V = 347.9692$$

The volume of the new cylinder is approximately 347.9692 cm cubed

20.

$$h = -16t^2 + 256$$

$$120 = -16t^2 + 256$$

$$-136 = -16t^2$$

$$8.5 = t^2$$

$$\sqrt{8.5} = \sqrt{t^2}$$

$$t = \sqrt{8.5}$$

$$t \approx 2.9155$$

The golf ball will reach a height of 120 feet at approximately 2.9155 seconds.

21.

s = the number of synthetic skeins and w = the number of wool skeins

$$12w + 9s = 432$$

$$12w + 9(16) = 432$$

$$12w + 144 = 432$$

$$12w = 288$$

$$w = 24$$

Joy sold 24 skeins of wool yarn.

22.

$$16 \geq |x - 4|$$

$$|x - 4| \leq 16$$

$$x - 4 \leq 16$$

$$x \leq 20$$

$$x - 4 \geq -16$$

$$x \geq -12$$

$$20 \geq x \geq -12$$

23.

$$\begin{cases} y \leq 2x - 4 \\ y > -\frac{1}{4}x + 6 \end{cases}$$

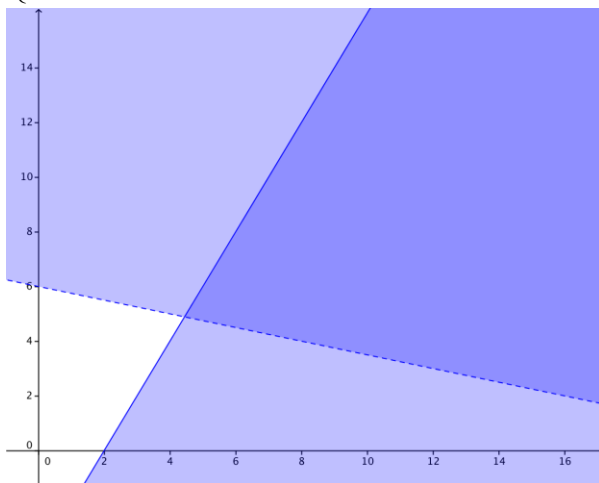

24.

February 2011 had 28 and 4 Mondays. The probability of landing on a Monday is $4/28$ or $1/7$.

25.

$$y = a(b)^x$$

$a = \text{initial amount}$

$$b = \text{decay factor} = \frac{1}{2}$$

$$x = \text{time} \div 5730$$

$$y = a\left(\frac{1}{2}\right)^{\frac{x}{5730}}$$

26.

Inconsistent systems have no solutions.

Lesson 11.4

The Pythagorean Theorem and its Converse

1.

$$a^2 + b^2 = c^2$$

$$12^2 + 9^2 = 15^2$$

$$144 + 81 = 225$$

$$225 = 225$$

Yes this is a right triangle.

2.

$$a^2 + b^2 = c^2$$

$$6^2 + 6^2 = (6\sqrt{2})^2$$

$$36 + 36 = 36 * 2$$

$$72 = 72$$

Yes this is a right triangle.

3.

$$a^2 + b^2 = c^2$$

$$8^2 + (8\sqrt{3})^2 = 16^2$$

$$64 + (64 * 3) = 256$$

$$256 = 256$$

Yes this is a right triangle.

4.

$$a^2 + b^2 = c^2$$

$$12^2 + 16^2 = c^2$$

$$144 + 256 = c^2$$

$$400 = c^2$$

$$\sqrt{400} = \sqrt{c^2}$$

$$c = 20$$

5.

$$a^2 + b^2 = c^2$$

$$a^2 + 20^2 = 30^2$$

$$a^2 + 400 = 900$$

$$a^2 = 500$$

$$\sqrt{a^2} = \sqrt{500}$$

$$a = \sqrt{100} * \sqrt{5}$$

$$a = 10\sqrt{5}$$

6.

$$a^2 + b^2 = c^2$$

$$4^2 + b^2 = 11^2$$

$$16 + b^2 = 121$$

$$b^2 = 105$$

$$\sqrt{b^2} = \sqrt{105}$$

$$b = \sqrt{100} * \sqrt{1.05}$$

$$b = 10\sqrt{1.05}$$

7.

$$a^2 + b^2 = c^2$$

$$9^2 + 7^2 = c^2$$

$$81 + 49 = c^2$$

$$130 = c^2$$

$$\sqrt{130} = \sqrt{c^2}$$

$$c = \sqrt{100} * \sqrt{1.3}$$

$$c = 10\sqrt{1.3}$$

8.

$$a^2 + b^2 = c^2$$

$$a^2 + 21^2 = 35^2$$

$$a^2 + 441 = 1225$$

$$a^2 = 784$$

$$\sqrt{a^2} = \sqrt{784}$$

$$a = 28$$

9.

$$a^2 + b^2 = c^2$$

$$12^2 + b^2 = 24^2$$

$$144 + b^2 = 576$$

$$b^2 = 432$$

$$\sqrt{b^2} = \sqrt{432}$$

$$b = \sqrt{144} * \sqrt{3}$$

$$b = 12\sqrt{3}$$

10.

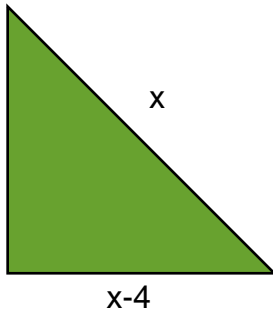

$$a^2 + b^2 = c^2$$

$$12^2 + (x-4)^2 = x^2$$

$$144 + (x^2 - 8x + 16) = x^2$$

$$144 + x^2 - 8x + 16 - x^2 = 0$$

$$-8x + 160 = 0$$

$$-8x = -160$$

$$x = 20$$

The hypotenuse = 20

leg one = 12

leg two = 16

11.

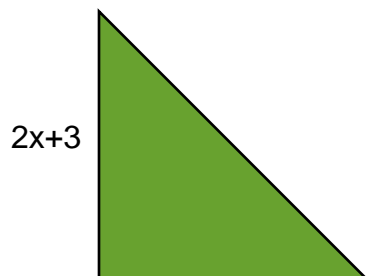

$$a^2 + b^2 = c^2$$

$$x^2 + (2x + 3)^2 = (3x)^2$$

$$x^2 + 4x^2 + 12x + 9 = 9x^2$$

$$0 = 4x^2 - 12x - 9$$

$$y = \frac{-b \pm \sqrt{b^2 - 4ac}}{2a}$$

$$y = \frac{-(-12) \pm \sqrt{(-12)^2 - 4(4)(-9)}}{2(4)}$$

$$y = \frac{12 \pm \sqrt{144 + 144}}{8}$$

$$y = \frac{12 \pm \sqrt{288}}{8}$$

$$y = \frac{12 + \sqrt{288}}{8} \approx \frac{12 + 16.9706}{8} \approx \frac{28.9706}{8} \approx 3.6213$$

$$y = \frac{12 - \sqrt{288}}{8} \approx \frac{12 - 16.9706}{8} \approx \frac{-4.9706}{8} \approx -0.6213$$

The sides of a triangle cannot be negative, so the solution is:

$$x = 3.6213$$

$$2x + 3 = 2(3.6213) + 3 = 10.2426$$

$$3x = 3(3.6213) = 10.8639$$

12.

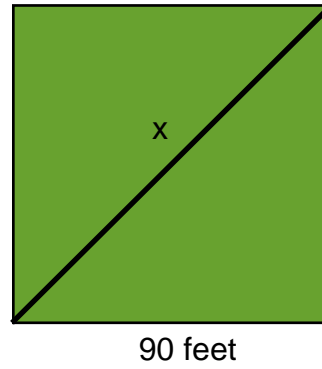
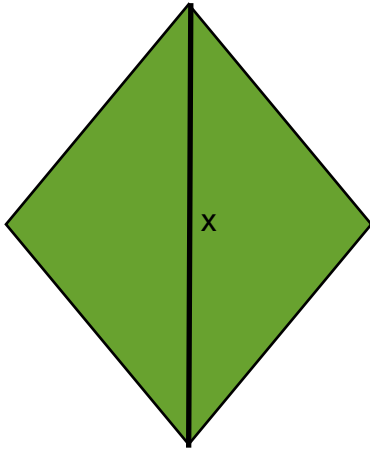

The diagonal created by home plate and second base is the hypotenuse of a right triangle.

$$a^2 + b^2 = c^2$$

$$90^2 + 90^2 = c^2$$

$$8100 + 8100 = c^2$$

$$16200 = c^2$$

$$\sqrt{16200} = \sqrt{c^2}$$

$$c = \sqrt{16200}$$

$$c \approx 127.2792$$

Second base is approximately 127.2792 feet from home plate.

13.

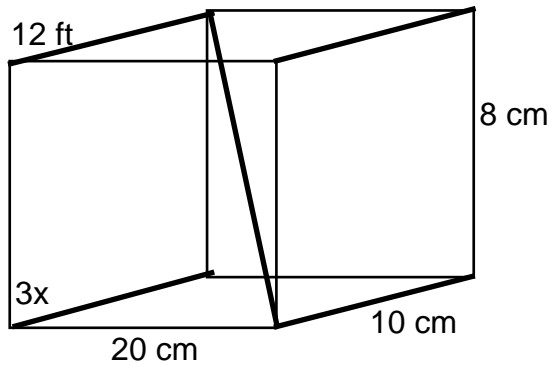

The diagonal we have to find is the hypotenuse of a right triangle whose legs are the height and the diagonal of the bottom of the box. Let's find that diagonal first.

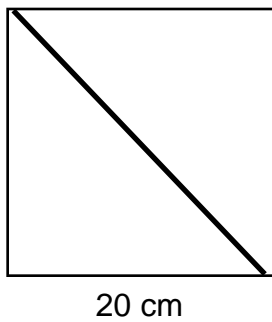

$$\begin{aligned}
 a^2 + b^2 &= c^2 \\
 20^2 + 10^2 &= c^2 \\
 400 + 100 &= c^2 \\
 500 &= c^2 \\
 \sqrt{500} &= \sqrt{c^2} \\
 c &\approx 22.3607
 \end{aligned}$$

Now we have two legs of the triangle and can find the hypotenuse (the diagonal of the box).

$$\begin{aligned}
 a^2 + b^2 &= c^2 \\
 8^2 + 22.3607^2 &= c^2 \\
 64 + 500 &= c^2 \\
 564 &= c^2 \\
 \sqrt{564} &= \sqrt{c^2} \\
 c &\approx 23.7487
 \end{aligned}$$

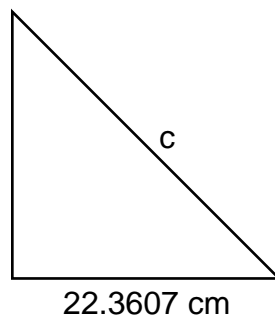

The diagonal is approximately 23.75 cm.

14.

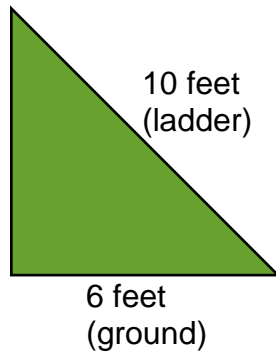

$$a^2 + b^2 = c^2$$

$$x^2 + 6^2 = 10^2$$

$$x^2 + 36 = 100$$

$$x^2 = 64$$

$$\sqrt{x^2} = \sqrt{64}$$

$$x = 8$$

The ladder touches the wall of the house 8 feet above the ground.

15.

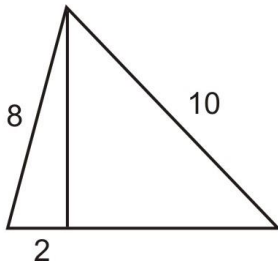

We can find the height by using Pythagorean Theorem on the smaller triangle.

$$a^2 + b^2 = c^2$$

$$a^2 + 2^2 = 8^2$$

$$a^2 + 4 = 64$$

$$a^2 = 60$$

$$\sqrt{a^2} = \sqrt{60}$$

$$a = \sqrt{4} * \sqrt{15}$$

$$a = 2\sqrt{15}$$

We can find the base by again using Pythagorean Theorem on the bigger triangle and adding 2.

$$a^2 + b^2 = c^2$$

$$(2\sqrt{15})^2 + b^2 = 10^2$$

$$(4 * 15) + b^2 = 100$$

$$60 + b^2 = 100$$

$$b^2 = 40$$

$$\sqrt{b^2} = \sqrt{40}$$

$$b = \sqrt{4} * \sqrt{10}$$

$$a = 2\sqrt{10}$$

Now we use the formula to find the area.

$$A = \frac{1}{2}bh$$

$$A = \frac{1}{2}(2\sqrt{10} + 2)(2\sqrt{15})$$

$$A = \frac{1}{2}(4\sqrt{150} + 4\sqrt{15})$$

$$A = 2\sqrt{150} + 2\sqrt{15}$$

$$A \approx 32.2409$$

The area of the triangle is approximately 32. 2409

16.

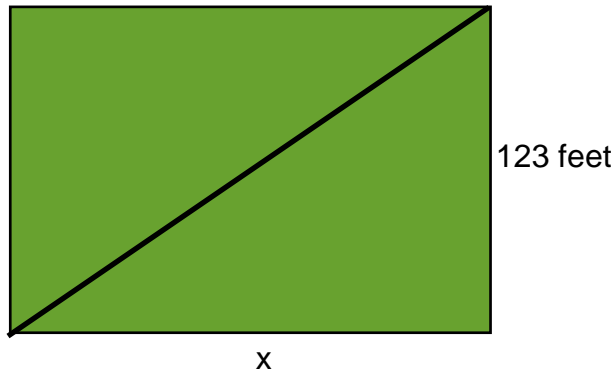

We know the short side is 123 feet. We know the diagonal (hypotenuse) saves Mario $\frac{1}{2}$ the length of the long side. If we call the long side x then the hypotenuse is $123 + \frac{1}{2}x$. Now we solve using the Pythagorean Theorem.

$$a^2 + b^2 = c^2$$

$$x^2 + 123^2 = (0.5x + 123)^2$$

$$x^2 + 15129 = 0.25x^2 + 123x + 15129$$

$$x^2 + 15129 - 0.25x^2 - 123x - 15129 = 0$$

$$0.75x^2 - 123x = 0$$

$$x = \frac{-b \pm \sqrt{b^2 - 4ac}}{2a}$$

$$x = \frac{-(-123) \pm \sqrt{(-123)^2 - 4(0.75)(0)}}{2(0.75)}$$

$$x = \frac{123 \pm \sqrt{15129 - 0}}{1.5}$$

$$x = \frac{123 \pm \sqrt{15129}}{1.5}$$

$$x = \frac{123 \pm \sqrt{15129}}{1.5} = \frac{123 + 123}{1.5} = \frac{246}{1.5} = 164$$

$$x = \frac{123 \pm \sqrt{15129}}{1.5} = \frac{123 - 123}{1.5} = \frac{0}{1.5} = 0$$

The long side is 164 feet.

17.

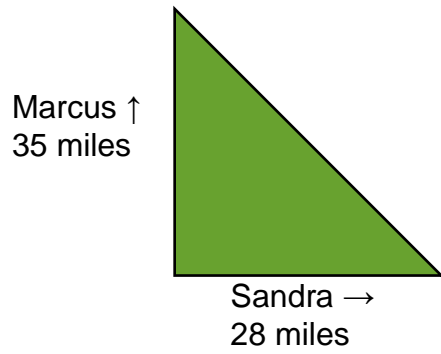

$$a^2 + b^2 = c^2$$

$$28^2 + 35^2 = c^2$$

$$784 + 1225 = c^2$$

$$2009 = c^2$$

$$\sqrt{2009} = \sqrt{c^2}$$

$$c = \sqrt{2009}$$

$$c \approx 44.8219$$

The two boats are approximately 44.8219 miles apart after two hours.

18.

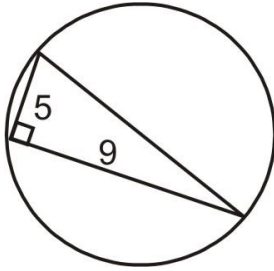

The hypotenuse of the triangle is the diameter of the circle. We will find the length of the hypotenuse using Pythagorean Theorem.

$$a^2 + b^2 = c^2$$

$$5^2 + 9^2 = c^2$$

$$25 + 81 = c^2$$

$$106 = c^2$$

$$\sqrt{106} = \sqrt{c^2}$$

$$c = \sqrt{106}$$

$$c \approx 10.2956$$

The diameter of the circle is approximately 10.2956. To find the area we need the radius, which is half of the diameter. $10.2956/2=5.1478$

$$A = \pi r^2$$

$$A = (3.14)(5.1478^2)$$

$$A = (3.14)(26.4998)$$

$$A = 83.2094$$

The area of the circle is approximately 83.2094

19.

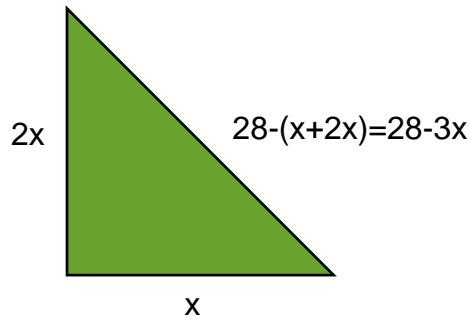

$$a^2 + b^2 = c^2$$

$$x^2 + (2x)^2 = (28 - 3x)^2$$

$$x^2 + 4x^2 = 784 - 84x - 84x + 9x^2$$

$$5x^2 = 9x^2 - 168x + 784$$

$$0 = 4x^2 - 168x + 784$$

$$y = \frac{-b \pm \sqrt{b^2 - 4ac}}{2a}$$

$$y = \frac{-(-168) \pm \sqrt{(-168)^2 - 4(4)(784)}}{2(4)}$$

$$y = \frac{168 \pm \sqrt{28224 - 12544}}{8}$$

$$y = \frac{168 \pm \sqrt{15680}}{8}$$

$$y = \frac{168 + \sqrt{15680}}{8} \approx \frac{168 + 125.2198}{8} \approx \frac{293.2198}{8} \approx 36.6525$$

$$y = \frac{168 - \sqrt{15680}}{8} \approx \frac{168 - 125.2198}{8} \approx \frac{42.7802}{8} \approx 5.3475$$

There are two possible sets of solutions.

$$x = 36.6525$$

$$2x = 73.305$$

$$28 - 3x = -81.9575$$

This is an extraneous solution. (The length of the hypotenuse cannot be negative.)

$$x = 5.3475$$

$$2x = 10.695$$

$$28 - 3x = 11.9575$$

The sides of the triangle are approximately 5.3475, 10.695, and 11.9575

20.

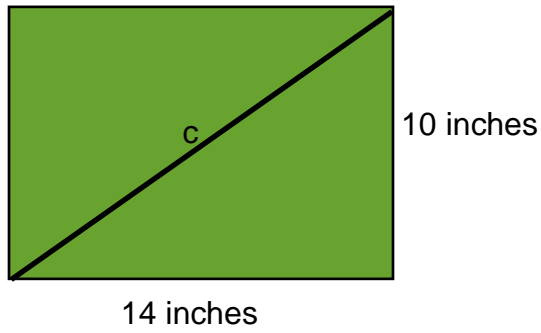

$$a^2 + b^2 = c^2$$

$$10^2 + 14^2 = c^2$$

$$100 + 196 = c^2$$

$$296 = c^2$$

$$\sqrt{296} = \sqrt{c^2}$$

$$c = \sqrt{296}$$

$$c \approx 17.2047$$

The length of the diagonal is approximately 17.2047 inches

21.

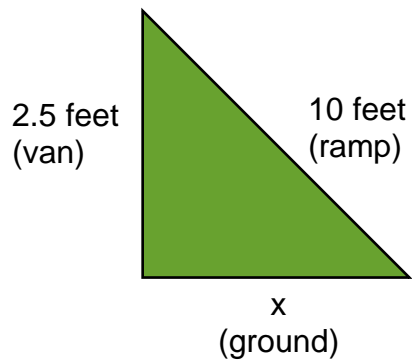

$$a^2 + b^2 = c^2$$

$$2.5^2 + x^2 = 10^2$$

$$6.25 + x^2 = 100$$

$$x^2 = 93.75$$

$$\sqrt{x^2} = \sqrt{93.75}$$

$$x = \sqrt{93.75}$$

$$x \approx 9.6825$$

The ramp extends approximately 9.6825 feet past the back of the van.

Mixed Review

22.

1.

$$y = a(b)^x$$

$$y = 121000(100\% + 1.2\%)^x$$

$$y = 121000(1.012)^x$$

$$y = 121000(1.012)^{13}$$

$$y = 121000(1.1677)$$

$$y = 141291.7$$

The population in 13 years will be approximately 141,292

2.

$$y = a(b)^x$$

$$y = 121000(100\% - 1.2\%)^x$$

$$y = 121000(0.988)^x$$

$$y = 121000(0.988)^5$$

$$y = 121000(0.9414)$$

$$y = 113909.4$$

$$y = 113909.4$$

The population 5 years ago was approximately 113,909

23. $1.29651843 \cdot 10^5 = 129651.843$

24.

$$4, 2, 1, \frac{1}{2}, \frac{1}{6}, \frac{1}{8} \dots$$

$$2 \div 4 = \frac{1}{2}$$

$$2 \div 1 = \frac{1}{2}$$

$$1 \div \frac{1}{2} = 2$$

$$\frac{1}{2} \div \frac{1}{6} = 3$$

$$\frac{1}{6} \div \frac{1}{8} = 1\frac{1}{3}$$

No, this is not a geometric sequence. In a geometric sequence each successive number is found by multiplying the number before by a common ratio. Since these numbers do not have a common ratio, it is not a geometric sequence.

25.

$$6x^3(4xy^2 + y^3z) = 24x^4y^2 + 6x^3y^3z$$

26.

$$0 = (x-2)(x+1)(x-3)$$

$$0 = (x^2 + x - 2x - 2)(x-3)$$

$$0 = (x^2 - x - 2)(x-3)$$

$$0 = x^3 - x^2 - 2x - 3x^2 - 3x + 6$$

$$0 = x^3 - 4x^2 - 5x + 6$$

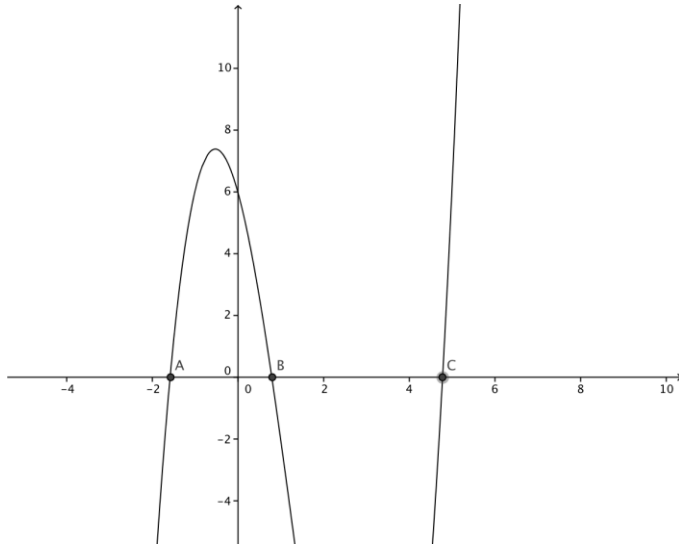

x-intercepts = (-1.58, 0) (0.79, 0) (4.78, 0)

27. $\sqrt{300} = \sqrt{100} * \sqrt{3} = 10\sqrt{3} \approx 17.3205$

Quick Quiz

1.

$$f(x) = \sqrt{x-h} + k$$

$$h(x) = \sqrt{x-2} + 5$$

$$(h, k) = (2, 5)$$

The origin of the curve is (2,5).

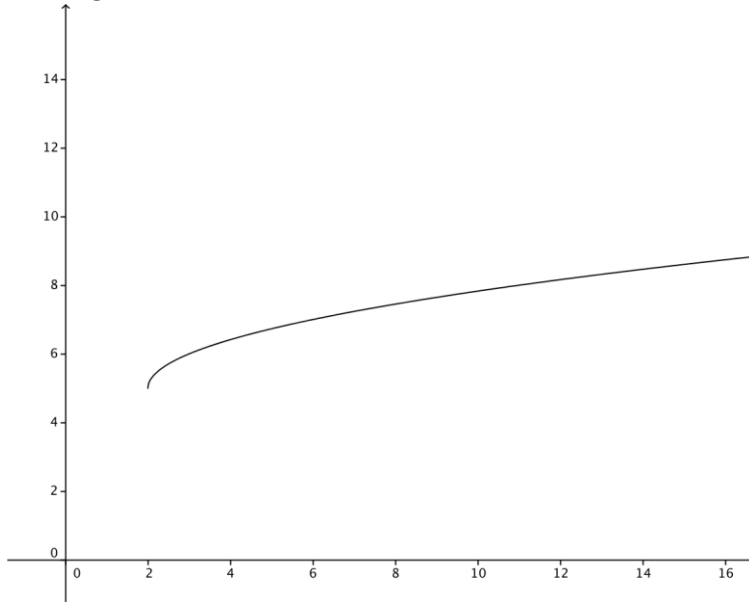

2.

$$\frac{6}{\sqrt[3]{2}} = \frac{6}{\sqrt[3]{2}} * \frac{\sqrt[3]{2^2}}{\sqrt[3]{2^2}} = \frac{6\sqrt[3]{4}}{2} = 3\sqrt[3]{4}$$

3. $\sqrt[4]{-32}$ This problem has no real solution. It is impossible to take an even root (4) of a negative number (-32).

4. An extraneous solution is a solution that occurs when a radical equation is solved, but the solution is not a possible solution for the equation. These solutions occur because you cannot have an even root of a negative number and sometimes the solution that you find results in this situation.

5.

$$a^2 + b^2 = c^2$$

$$3^2 + 4^2 = 6^2$$

$$9 + 16 = 36$$

$$25 \neq 36$$

No 3,4,6 cannot form a right triangle.

6.

$$5 = \sqrt[3]{y+6}$$

$$5^3 = (\sqrt[3]{y+6})^3$$

$$125 = y+6$$

$$119 = y$$

Lesson 11.5

The Distance and Midpoint Formulas

$$1. d = \sqrt{(y_2 - y_1)^2 + (x_2 - x_1)^2}$$

2.

$$d = \sqrt{(y_2 - y_1)^2 + (x_2 - x_1)^2}$$

$$d = \sqrt{(7 - 7)^2 + (-7 - 7)^2}$$

$$d = \sqrt{(0)^2 + (-14)^2}$$

$$d = \sqrt{0 + 196}$$

$$d = \sqrt{196}$$

$$d = 14$$

3.

$$d = \sqrt{(y_2 - y_1)^2 + (x_2 - x_1)^2}$$

$$d = \sqrt{(-6 - 6)^2 + (3 - (-3))^2}$$

$$d = \sqrt{(-12)^2 + (6)^2}$$

$$d = \sqrt{144 + 36}$$

$$d = \sqrt{180}$$

$$d = \sqrt{36} * \sqrt{5} = 6\sqrt{5}$$

$$d \approx 13.4164$$

4.

$$d = \sqrt{(y_2 - y_1)^2 + (x_2 - x_1)^2}$$

$$d = \sqrt{(-8 - (-1))^2 + (-5 - (-3))^2}$$

$$d = \sqrt{(-7)^2 + (-2)^2}$$

$$d = \sqrt{49 + 4}$$

$$d = \sqrt{53}$$

$$d \approx 7.2801$$

5.

$$d = \sqrt{(y_2 - y_1)^2 + (x_2 - x_1)^2}$$

$$d = \sqrt{(0 - (-4))^2 + (6 - 3)^2}$$

$$d = \sqrt{(4)^2 + (3)^2}$$

$$d = \sqrt{16 + 9}$$

$$d = \sqrt{25}$$

$$d = 5$$

6.

$$d = \sqrt{(y_2 - y_1)^2 + (x_2 - x_1)^2}$$

$$d = \sqrt{(2 - 0)^2 + (4 - (-1))^2}$$

$$d = \sqrt{(2)^2 + (5)^2}$$

$$d = \sqrt{4 + 25}$$

$$d = \sqrt{29}$$

$$d \approx 5.3852$$

7.

$$d = \sqrt{(y_2 - y_1)^2 + (x_2 - x_1)^2}$$

$$d = \sqrt{(2 - 2)^2 + (6 - (-3))^2}$$

$$d = \sqrt{(0)^2 + (9)^2}$$

$$d = \sqrt{0 + 81}$$

$$d = \sqrt{81}$$

$$d = 9$$

8.

$$d = \sqrt{(y_2 - y_1)^2 + (x_2 - x_1)^2}$$

$$d = \sqrt{(-4 - (-2.5))^2 + (4 - 0.5)^2}$$

$$d = \sqrt{(-1.5)^2 + (3.5)^2}$$

$$d = \sqrt{2.25 + 12.25}$$

$$d = \sqrt{14.5}$$

$$d \approx 3.8079$$

9.

$$d = \sqrt{(y_2 - y_1)^2 + (x_2 - x_1)^2}$$

$$d = \sqrt{(-6 - (-10))^2 + (0 - 12)^2}$$

$$d = \sqrt{(4)^2 + (12)^2}$$

$$d = \sqrt{16 + 144}$$

$$d = \sqrt{160} = \sqrt{16} * \sqrt{10} = 4\sqrt{10}$$

$$d \approx 12.6491$$

10.

$$d = \sqrt{(y_2 - y_1)^2 + (x_2 - x_1)^2}$$

$$d = \sqrt{(-5.2 - 4.5)^2 + (-3.4 - 2.3)^2}$$

$$d = \sqrt{(-9.7)^2 + (-5.7)^2}$$

$$d = \sqrt{94.09 + 32.49}$$

$$d = \sqrt{126.58}$$

$$d \approx 11.2508$$

11.

$$d = \sqrt{(y_2 - y_1)^2 + (x_2 - x_1)^2}$$

$$10 = \sqrt{(2 - y)^2 + (4 - (-4))^2}$$

$$10 = \sqrt{(2 - y)^2 + (8)^2}$$

$$10 = \sqrt{(2 - y)^2 + 64}$$

$$10^2 = \left(\sqrt{(2 - y)^2 + 64} \right)^2$$

$$100 = (2 - y)^2 + 64$$

$$36 = 4 - 2y - 2y + y^2$$

$$0 = y^2 - 4y + 4 - 36$$

$$0 = y^2 - 4y - 32$$

$$32 = y^2 - 4y$$

$$32 + 4 = y^2 - 4y + 4$$

$$36 = (y - 2)^2$$

$$\sqrt{36} = \sqrt{(y - 2)^2}$$

$$6 = \pm(y - 2)$$

$$6 = (y - 2)$$

$$8 = y$$

$$6 = -(y - 2)$$

$$6 = -y + 2$$

$$4 = -y$$

$$-4 = y$$

The points are (-4,8) and (-4,-4)

12.

$$d = \sqrt{(y_2 - y_1)^2 + (x_2 - x_1)^2}$$

$$8 = \sqrt{(5 - 3)^2 + (-2 - x)^2}$$

$$8 = \sqrt{(2)^2 + (-2 - x)^2}$$

$$8 = \sqrt{4 + (-2 - x)^2}$$

$$8^2 = \left(\sqrt{4 + (-2 - x)^2} \right)^2$$

$$64 = 4 + (-2 - x)^2$$

$$60 = (-2 - x)^2$$

$$60 = 4 + 2x + 2x + x^2$$

$$0 = x^2 + 4x + 4 - 60$$

$$0 = x^2 + 4x - 56$$

$$56 = x^2 + 4x$$

$$56 + 4 = x^2 + 4x + 4$$

$$60 = (x + 2)^2$$

$$\sqrt{60} = \sqrt{(x + 2)^2}$$

$$\sqrt{4} * \sqrt{15} = \pm(x + 2)$$

$$7.746 = x + 2$$

$$5.746 = x$$

$$-7.746 = x + 2$$

$$-9.746 = x$$

The points are (5.746, 3) and (-9.746, 3)

$$13. \quad (x_m, y_m) = \frac{(x_1 + x_2)}{2}, \frac{(y_1 + y_2)}{2}$$

14.

$$(x_m, y_m) = \frac{(x_1 + x_2)}{2}, \frac{(y_1 + y_2)}{2}$$

$$(x_m, y_m) = \frac{(7 + (-7))}{2}, \frac{(7 + 7)}{2}$$

$$(x_m, y_m) = \frac{(0)}{2}, \frac{(14)}{2} = (0, 7)$$

15.

$$(x_m, y_m) = \frac{(x_1 + x_2)}{2}, \frac{(y_1 + y_2)}{2}$$

$$(x_m, y_m) = \frac{(-3 + 3)}{2}, \frac{(6 + (-6))}{2}$$

$$(x_m, y_m) = \frac{(0)}{2}, \frac{(0)}{2} = (0, 0)$$

16.

$$(x_m, y_m) = \frac{(x_1 + x_2)}{2}, \frac{(y_1 + y_2)}{2}$$

$$(x_m, y_m) = \frac{(-3 + (-5))}{2}, \frac{(-1 + (-8))}{2}$$

$$(x_m, y_m) = \frac{(-8)}{2}, \frac{(-9)}{2} = (-4, -4.5)$$

17.

$$(x_m, y_m) = \frac{(x_1 + x_2)}{2}, \frac{(y_1 + y_2)}{2}$$

$$(x_m, y_m) = \frac{(3 + 6)}{2}, \frac{(-4 + 1)}{2}$$

$$(x_m, y_m) = \frac{(9)}{2}, \frac{(-3)}{2} = (4.5, -1.5)$$

18.

$$(x_m, y_m) = \frac{(x_1 + x_2)}{2}, \frac{(y_1 + y_2)}{2}$$

$$(x_m, y_m) = \frac{(2 + 2)}{2}, \frac{(-3 + 4)}{2}$$

$$(x_m, y_m) = \frac{(4)}{2}, \frac{(1)}{2} = (2, 0.5)$$

19.

$$(x_m, y_m) = \frac{(x_1 + x_2)}{2}, \frac{(y_1 + y_2)}{2}$$

$$(x_m, y_m) = \frac{(4 + 8)}{2}, \frac{(-5 + 2)}{2}$$

$$(x_m, y_m) = \frac{(12)}{2}, \frac{(-3)}{2} = (6, -1.5)$$

20.

$$(x_m, y_m) = \frac{(x_1 + x_2)}{2}, \frac{(y_1 + y_2)}{2}$$

$$(x_m, y_m) = \frac{(1.8 + (-0.4))}{2}, \frac{(-3.4 + 1.4)}{2}$$

$$(x_m, y_m) = \frac{(1.4)}{2}, \frac{(-2)}{2} = (0.7, -1)$$

21.

$$(x_m, y_m) = \frac{(x_1 + x_2)}{2}, \frac{(y_1 + y_2)}{2}$$

$$(x_m, y_m) = \frac{(5 + (-4))}{2}, \frac{(-1 + 0)}{2}$$

$$(x_m, y_m) = \frac{(1)}{2}, \frac{(-1)}{2} = (0.5, -0.5)$$

22.

$$(x_m, y_m) = \frac{(x_1 + x_2)}{2}, \frac{(y_1 + y_2)}{2}$$

$$(x_m, y_m) = \frac{(10 + 2)}{2}, \frac{(2 + (-4))}{2}$$

$$(x_m, y_m) = \frac{(12)}{2}, \frac{(-2)}{2} = (6, -1)$$

23.

$$x_m = \frac{(x_1 + x_2)}{2}$$

$$3 = \frac{(4 + x)}{2}$$

$$6 = 4 + x$$

$$2 = x$$

$$y_m = \frac{(y_1 + y_2)}{2}$$

$$-2 = \frac{(5 + y)}{2}$$

$$-4 = 5 + y$$

$$-9 = y$$

$$(x, y) = (2, -9)$$

24.

$$x_m = \frac{(x_1 + x_2)}{2}$$

$$0 = \frac{(-10 + x)}{2}$$

$$0 = -10 + x$$

$$10 = x$$

$$y_m = \frac{(y_1 + y_2)}{2}$$

$$4 = \frac{(-2 + y)}{2}$$

$$8 = -2 + y$$

$$10 = y$$

$$(x, y) = (10, 10)$$

25. If we say that Michelle's starting point is the origin, the following is the graph of her trip.

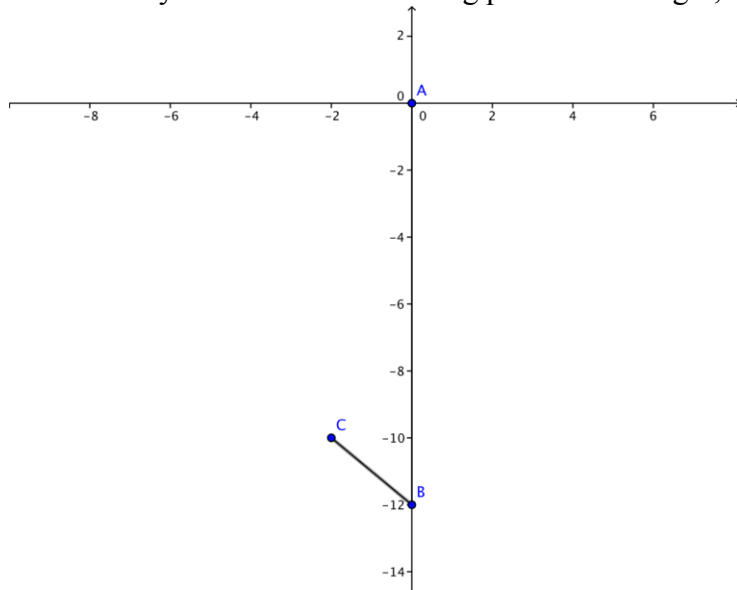

We know the distance from A to B is 12 miles, so we need to use the distance formula to find the distance between B and C.

$$d = \sqrt{(y_2 - y_1)^2 + (x_2 - x_1)^2}$$

$$d = \sqrt{(-10 - (-12))^2 + (-2 - 0)^2}$$

$$d = \sqrt{(2)^2 + (-2)^2}$$

$$d = \sqrt{4 + 4}$$

$$d = \sqrt{8}$$

$$d \approx 2.8284$$

The total distance is approximately 2.8284 miles + 12 miles = 14.8284 miles

26. The following graph represents the town.

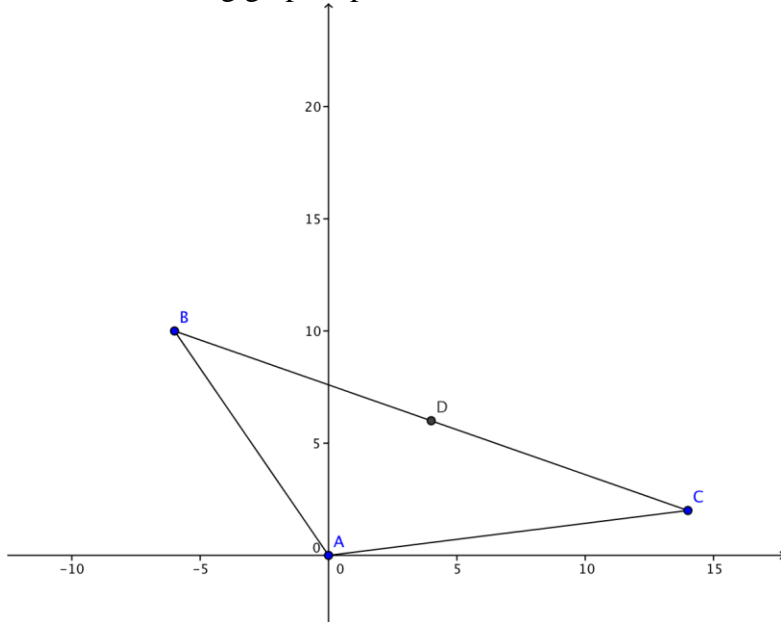

Point A (0,0) is the center of town.

Point B (-6,10) is Shawn's house.

Point C (14,2) is Kenya's house.

1.

$$d = \sqrt{(y_2 - y_1)^2 + (x_2 - x_1)^2}$$

$$d = \sqrt{(2 - 10)^2 + (14 - (-6))^2}$$

$$d = \sqrt{(-8)^2 + (20)^2}$$

$$d = \sqrt{64 + 400}$$

$$d = \sqrt{464} = \sqrt{16} * \sqrt{29} = 4\sqrt{29}$$

$$d \approx 21.5407$$

The two girls' houses are approximately 21.5407 blocks apart "as the crow flies".

2.

$$(x_m, y_m) = \left(\frac{x_1 + x_2}{2}, \frac{y_1 + y_2}{2} \right)$$

$$(x_m, y_m) = \left(\frac{-6 + 14}{2}, \frac{10 + 2}{2} \right)$$

$$(x_m, y_m) = \left(\frac{8}{2}, \frac{12}{2} \right) = (4, 6)$$

The halfway point between their houses is (4,6) or 4 blocks north and 6 blocks east of the center of town.

Mixed Review

27.

$$(x-4)^2 = 121$$

$$x^2 - 4x - 4x + 16 = 121$$

$$x^2 - 8x + 16 = 121$$

$$x^2 - 8x + 16 - 121 = 0$$

$$x^2 - 8x - 105 = 0$$

$$x^2 - 8x = 105$$

$$x^2 - 8x + 16 = 105 + 16$$

$$(x-4)^2 = 121$$

$$\sqrt{(x-4)^2} = \sqrt{121}$$

$$x-4 = \pm 11$$

$$x-4 = 11$$

$$x = 15$$

$$x-4 = -11$$

$$x = -7$$

$$x = 15, -7$$

28.

$$\left. \begin{array}{l} 21ab^4 \\ 15a^7b^2 \end{array} \right\} 3ab^2$$

29.

${}_{10}C_7$ is the symbol for a combination. A combination is an arrangement of objects in no particular order. 10 is the number of possible objects to choose from and 7 is the number of objects chosen at a time.

$${}_n C_k = \frac{n!}{k!(n-k)!}$$

$${}_{10} C_7 = \frac{10!}{7!(10-7)!}$$

$${}_{10} C_7 = \frac{3628800}{5040 * 6}$$

$${}_{10} C_7 = \frac{3628800}{30240}$$

$${}_{10} C_7 = 120$$

30.

$$6x^2 + 17x + 5$$

$$6x^2 + 2x + 15x + 5$$

$$2x(3x+1) + 5(3x+1)$$

$$(2x+5)(3x+1)$$

31.

$$A = l * w$$

$$l = 16 + 2m$$

$$w = 12 + 2m$$

$$A = (16 + 2m) * (12 + 2m)$$

$$A = 192 + 32m + 24m + 4m^2$$

$$A = 4m^2 + 56m + 192$$

$$A = 4(m^2 + 14m + 48)$$

$$A = 4(m + 6)(m + 8)$$

$$m + 6 = 0$$

$$m = -6$$

$$m + 8 = 0$$

$$m = -8$$

$$A = (16 + 2m) * (12 + 2m)$$

$$A = (16 + 2(-6)) * (12 + 2(-6))$$

$$A = (16 - 12)(12 - 12)$$

$$A = 4 * 0$$

$$A = 4$$

$$A = (16 + 2m) * (12 + 2m)$$

$$A = (16 + 2(-8)) * (12 + 2(-8))$$

$$A = (16 - 16)(12 - 16)$$

$$A = 0 * -4$$

$$A \neq -4$$

The area of the rectangle is 4.

32.

$$x^2 - 81$$

$$(x + 9)(x - 9)$$

Lesson 11.6

Measures of Central Tendency and Dispersion

1. Measures of Central Tendency are the central values of a data set. This lesson describes mean, median, and mode.

2. The Median is the the middle of the data set when put in ascending order. It may not be a number in the data set if the number of items in the set is even. If so, it will be the number exactly halfway between the two middle numbers of the set.

The mean is the traditional average. You find it by adding all of the numbers of the set and dividing that sum by the number of pieces of data in the set.

When data has a high range the median is a more accurate measure. The very high and very low numbers will skew the mean.

3. Bimodal is when a data set has two modes. (Answers to example will vary, any is correct as long as there are two numbers in the set that appear most often.)

4. The three measures of dispersion described in the lesson are range, variance, and standard deviation. Range is the easiest to compute.

$$\sigma^2 = \frac{(x_1 - \bar{x})^2 + (x_2 - \bar{x})^2 + \dots + (x_n - \bar{x})^2}{n}$$

5.

x_1 = the first number in the data set

x_2 = the second number in the data set

x_n = the last or nth number in the data set

n = the number of items in the data set

\bar{x} = is the mean of the data set

σ^2 = is the symbol for variance

6. Because the variance is squared, the number is often much larger than is useful. In the housing example the variance is in the billions, while the costs of the houses are all less than a million.

7. The standard deviation measures how closely the data clusters around the mean of the set. It is found by taking the square root of the variance.

8. Logically the standard deviation of a set where all the values are the same is zero because the standard deviation is a measure of the dispersion of the numbers. If all the values are the same, there is no dispersion.

Mathematically the standard deviation of a set where all the values are the same is zero because each set of parentheses in the formula will result in a zero (the value - the mean, the mean of a set of numbers that is all the same is the number) If each pair of parentheses results in zero, then the only possible answer, even after squaring, adding, dividing, and finding the square root, is 0.

9.

Mean = \bar{x} = average

$$\bar{x} = \frac{19630 + 28920 + 56330 + 49930 + 69030 + 39130 + 35460 + 2476590}{8}$$

$$\bar{x} = \$346,877.50$$

Median = middle#

$$Med = 19630, 28920, 35460, (39130, 49930), 56330, 69030, 2476590$$

$$Med = \frac{(39130 + 49930)}{2}$$

$$Med = \frac{89060}{2}$$

$$Med = \$44,530$$

Range = highest – lowest

$$R = 2476590 - 19630$$

$$R = \$2,456,960$$

10.

Mean = \bar{x} = average

$$\bar{x} = \frac{11+16+9+15+5+18}{6}$$

$$\bar{x} = \frac{74}{6}$$

$$\bar{x} \approx 12.3333$$

Median = middle#

Med = 5, 9, (11, 15), 16, 18

$$\text{Med} = \frac{(11+15)}{2}$$

$$\text{Med} = \frac{26}{2}$$

$$\text{Med} = 13$$

Mode = # appears > times

Mode = 5, 9, 11, 15, 16, 18

Mode = NONE

Range = highest - lowest

$$R = 18 - 5$$

$$R = 13$$

11.

Mean = \bar{x} = average

$$\bar{x} = \frac{53 + 32 + 49 + 24 + 62}{5}$$

$$\bar{x} = \frac{220}{5}$$

$$\bar{x} = 44$$

Median = middle#

Med = 24, 32, (49), 53, 62

Med = 49

Mode = # appears > times

Mode = 24, 32, 49, 53, 62

Mode = NONE

Range = highest – lowest

$$R = 62 - 24$$

$$R = 38$$

12.

Mean = \bar{x} = average

$$\bar{x} = \frac{11+9+19+9+19+9+13+11}{8}$$

$$\bar{x} = \frac{100}{8}$$

$$\bar{x} = 12.5$$

Median = middle#

Med = 9, 9, 9, (11, 11), 13, 19, 19

Med = 11

Mode = # appears > times

Mode = 9, 9, 9, 11, 11, 13, 19, 19

Mode = 9

Range = highest - lowest

$$R = 19 - 9$$

$$R = 10$$

13.

Mean = \bar{x} = average

$$\bar{x} = \frac{3+2+6+9+0+1+6+6+3+2+3+5}{12}$$

$$\bar{x} = \frac{46}{12}$$

$$\bar{x} \approx 3.8333$$

Median = middle#

Med = 0,1,2,2,3,(3,3),5,6,6,6,9

Med = 3

Mode = # appears > times

Mode = 0,1,2,2,3,3,3,5,6,6,6,9

Mode = 3,6

Range = highest – lowest

$$R = 9 - 0$$

$$R = 9$$

14.

Mean = \bar{x} = average

$$\bar{x} = \frac{2+17+1+-3+12+8+12+16}{8}$$

$$\bar{x} = \frac{65}{8}$$

$$\bar{x} = 8.125$$

Median = middle#

$$\text{Med} = -3, 1, 2, (8, 12), 12, 16, 17$$

$$\text{Med} = \frac{(8+12)}{2}$$

$$\text{Med} = \frac{20}{2}$$

$$\text{Med} = 10$$

Mode = # appears > times

$$\text{Mode} = -3, 1, 2, 8, 12, 12, 16, 17$$

$$\text{Mode} = 12$$

Range = highest - lowest

$$R = 17 - (-3)$$

$$R = 14$$

15.

Mean = \bar{x} = average

$$\bar{x} = \frac{11+21+6+17+9}{5}$$

$$\bar{x} = \frac{64}{5}$$

$$\bar{x} = 12.8$$

Median = middle#

$$\text{Med} = 6, 9, (11), 17, 21$$

$$\text{Med} = 11$$

Mode = # appears > times

$$\text{Mode} = 6, 9, 11, 17, 21$$

$$\text{Mode} = \text{NONE}$$

Range = highest – lowest

$$R = 21 - 6$$

$$R = 15$$

16.

Mean = \bar{x} = average

$$\bar{x} = \frac{223 + 121 + 227 + 433 + 122 + 193 + 397 + 276 + 303 + 199 + 197 + 265 + 366 + 401 + 222}{15}$$

$$\bar{x} = \frac{3945}{15}$$

$$\bar{x} = 263$$

Median = middle#

Med = 121, 122, 193, 197, 199, 222, 223, (227), 265, 276, 303, 366, 397, 401, 433

Med = 227

Mode = # appears > times

Mode = 121, 122, 193, 197, 199, 222, 223, 227, 265, 276, 303, 366, 397, 401, 433

Mode = NONE

Range = highest – lowest

R = 433 – 121

R = 312

17.

Mean = \bar{x} = average

$$\bar{x} = \frac{15+19+15+16+11+11+18+21+165+9+11+20+16+8+17+10+12+11+16+14}{20}$$

$$\bar{x} = \frac{435}{20}$$

$$\bar{x} = 21.75$$

Median = middle#

Med = 8,9,10,11,11,11,11,12,14,(15,15),16,16,16,17,18,19,20,21,165

Med = 15

$$\sigma = \sqrt{\frac{(x_1 - \bar{x})^2 + (x_2 - \bar{x})^2 + \dots + (x_n - \bar{x})^2}{n}}$$
$$\sigma = \sqrt{\frac{(8 - 21.75)^2 + (9 - 21.75)^2 + (10 - 21.75)^2 + (11 - 21.75)^2 + (11 - 21.75)^2 + (11 - 21.75)^2 + (11 - 21.75)^2 + (12 - 21.75)^2 + (14 - 21.75)^2 + (15 - 21.75)^2 + (15 - 21.75)^2 + (16 - 21.75)^2 + (16 - 21.75)^2 + (16 - 21.75)^2 + (17 - 21.75)^2 + (18 - 21.75)^2 + (19 - 21.75)^2 + (20 - 21.75)^2 + (21 - 21.75)^2 + (165 - 21.75)^2}{20}}$$

$$\sigma = \sqrt{\frac{21865.75}{20}}$$

$$\sigma = \sqrt{1093.2875}$$

$$\sigma \approx 33.0649$$

The median gives the best average.

18.

Mean = \bar{x} = average

$$\bar{x} = \frac{11+12+14+14+14+14+19}{7}$$

$$\bar{x} = \frac{98}{7}$$

$$\bar{x} = 14$$

Median = middle#

$$\text{Med} = 11, 12, 14, (14), 14, 14, 19$$

$$\text{Med} = 14$$

$$\sigma = \sqrt{\frac{(x_1 - \bar{x})^2 + (x_2 - \bar{x})^2 + \dots + (x_n - \bar{x})^2}{n}}$$

$$\sigma = \sqrt{\frac{(11-14)^2 + (12-14)^2 + (14-14)^2 + (14-14)^2 + (14-14)^2 + (14-14)^2 + (19-14)^2}{7}}$$

$$\sigma = \sqrt{\frac{38}{7}}$$

$$\sigma \approx \sqrt{5.4286}$$

$$\sigma \approx 2.3299$$

The mean and the median are the same.

19.

Mean = \bar{x} = average

$$\bar{x} = \frac{11+12+14+16+17+17+18}{7}$$

$$\bar{x} = \frac{105}{7}$$

$$\bar{x} = 15$$

Median = middle#

$$\text{Med} = 11, 12, 14, (16), 17, 17, 18$$

$$\text{Med} = 16$$

$$\sigma = \sqrt{\frac{(x_1 - \bar{x})^2 + (x_2 - \bar{x})^2 + \dots + (x_n - \bar{x})^2}{n}}$$

$$\sigma = \sqrt{\frac{(11-15)^2 + (12-15)^2 + (14-15)^2 + (16-15)^2 + (17-15)^2 + (17-15)^2 + (18-15)^2}{7}}$$

$$\sigma = \sqrt{\frac{44}{7}}$$

$$\sigma \approx \sqrt{6.2857}$$

$$\sigma \approx 2.5071$$

The mean and the median are so close that either makes an acceptable average.

20.

Mean = \bar{x} = average

$$\bar{x} = \frac{6+7+9+10+13}{5}$$

$$\bar{x} = \frac{45}{5}$$

$$\bar{x} = 9$$

Median = middle#

Med = 6, 7, (9), 10, 13

Med = 9

$$\sigma = \sqrt{\frac{(x_1 - \bar{x})^2 + (x_2 - \bar{x})^2 + \dots + (x_n - \bar{x})^2}{n}}$$

$$\sigma = \sqrt{\frac{(6-9)^2 + (7-9)^2 + (9-9)^2 + (10-9)^2 + (13-9)^2}{5}}$$

$$\sigma = \sqrt{\frac{30}{5}}$$

$$\sigma = \sqrt{6}$$

$$\sigma \approx 2.4495$$

The mean and the median are the same.

21.

Mean = \bar{x} = average

$$\bar{x} = \frac{121+122+193+197+199+222+223+227+265+276+303+366+397+401+433}{15}$$

$$\bar{x} = \frac{3945}{15}$$

$$\bar{x} = 263$$

Median = middle#

Med = 121, 122, 193, 197, 199, 222, 223, (227), 265, 276, 303, 366, 397, 401, 433

Med = 227

$$\sigma = \sqrt{\frac{(x_1 - \bar{x})^2 + (x_2 - \bar{x})^2 + \dots + (x_n - \bar{x})^2}{n}}$$

$$\sigma = \sqrt{\frac{(121-263)^2 + (122-263)^2 + (193-263)^2 + (197-263)^2 + (199-263)^2 + (222-263)^2 + (223-263)^2 + (227-263)^2 + (265-263)^2 + (276-263)^2 + (303-263)^2 + (366-263)^2 + (397-263)^2 + (401-263)^2 + (433-263)^2}{15}}$$

$$\sigma = \sqrt{\frac{136256}{15}}$$

$$\sigma \approx \sqrt{9083.7333}$$

$$\sigma \approx 95.3086$$

The mean is probably the best average.

22.

- a. The mean will also increase by 7 points.
- b. The median will also increase by 7 points.
- c. The mode will also increase by 7 points. If there is no mode, there still will be none.
- d. The range will stay the same.
- e. The standard deviation will remain the same.

23.

- a. The mean is doubled.
- b. The median is doubled.
- c. The mode is doubled. If there is no mode, there still will be none.
- d. The range will be doubled.

24.

$$86 = \frac{88 + 76 + 97 + 84 + x}{5}$$

$$430 = 88 + 76 + 97 + 84 + x$$

$$342 = 76 + 97 + 84 + x$$

$$266 = 97 + 84 + x$$

$$169 = 84 + x$$

$$85 = x$$

Henry must score an 85 on his fifth test to have an average of 86.

25.

$$93 = \frac{88 + 76 + 97 + 84 + x}{5}$$

$$465 = 88 + 76 + 97 + 84 + x$$

$$377 = 76 + 97 + 84 + x$$

$$301 = 97 + 84 + x$$

$$204 = 84 + x$$

$$120 = x$$

It is not possible for Henry to have an average of 93 after his fifth test because it would require scoring 120 on what we can assume is a 100 point test.

26.

$$105 = \frac{x}{9}$$

$$945 = x$$

The sum of the 9 numbers is 945

27.

$$\bar{x} = \frac{163 + 187 + 194 + 188 + 205 + 196}{6}$$

$$\bar{x} = \frac{1133}{6}$$

$$\bar{x} = 188.8333$$

The bowler's average is approximately 189

28.

a.

Mean = \bar{x} = average

$$\bar{x} = \frac{38 + 45 + 58 + 38 + 36}{5}$$

$$\bar{x} = \frac{215}{5}$$

$$\bar{x} = 43$$

b.

$$\sigma = \sqrt{\frac{(x_1 - \bar{x})^2 + (x_2 - \bar{x})^2 + \dots + (x_n - \bar{x})^2}{n}}$$

$$\sigma = \sqrt{\frac{(38 - 43)^2 + (45 - 43)^2 + (58 - 43)^2 + (38 - 43)^2 + (36 - 43)^2}{5}}$$

$$\sigma = \sqrt{\frac{328}{5}}$$

$$\sigma = \sqrt{65.6}$$

$$\sigma \approx 8.0994$$

c. The mean is not necessarily the most accurate measure of central tendency for this example because the one score of 58 is so much larger than the others. This skews the average when finding the mean. Both the median and mode are 38, a more accurate number.

29.

Mean = \bar{x} = average

$$\bar{x} = \left(\frac{1137 + 879 + 950 + 875 + 1499 + 875 + 4000 + 975 + 796.793 + 2100}{10} \right) (1000)$$

$$\bar{x} = \left(\frac{14086.793}{10} \right) (1000)$$

$$\bar{x} = (1408.6793)(1000)$$

$$\bar{x} = \$1408679.30$$

Median = middle#

Med = 796793, 875000, 875000, 879000, (950000, 975000), 1137000, 1499000, 2100000, 4000000

$$\text{Med} = \frac{950000 + 975000}{2}$$

$$\text{Med} = \frac{1925000}{2}$$

$$\text{Med} = \$962,500$$

$$\sigma = \sqrt{\frac{(x_1 - \bar{x})^2 + (x_2 - \bar{x})^2 + \dots + (x_n - \bar{x})^2}{n}}$$

$$\sigma = \sqrt{\frac{(1137000 - 1408679.3)^2 + (879000 - 1408679.3)^2 + (950000 - 1408679.3)^2 + (875000 - 1408679.3)^2 + (1499000 - 1408679.3)^2 + (875000 - 1408679.3)^2 + (4000000 - 1408679.3)^2 + (975000 - 1408679.3)^2 + (796793 - 1408679.3)^2 + (2100000 - 1408679.3)^2}{10}}$$

$$\sigma = \sqrt{\frac{8897891382360}{10}}$$

$$\sigma = \sqrt{889789138236}$$

$$\sigma \approx 943286.35$$

The median is most often used as a measure of house prices in an area because it is not skewed by numbers at the high and low end of the range, which may be much higher or lower than most of the prices. The mean is skewed by these numbers at the far end of the range and the mode is simply unreliable (as there may be no mode or multiple modes.)

30.

(a) median

(b) median

(c) mean

31.

James- James' argument for planting by hand is valid because, as shown in the table, the mean diameter of the cabbages is larger. This means in general the cabbages planted by hand are bigger.

John- Johns' argument for planting by machine is valid because, as shown in the table, the standard deviation for the machine planted cabbages is smaller. This means that the cabbages are closer in size. John will be selling a more uniform product.

32.

(a) Samantha should take Fast-dog travel if she is trying to catch a plane. Their mean time is less and so on any given day it is more likely that she will get there in less time.

(b) Samantha should take the Inter-Cal express if she is making weekly visits and wants to reduce her overall time. Their standard deviation is less so she is more likely to make the mean time on each of her trips and spend less time overall.

Mixed Review

33.

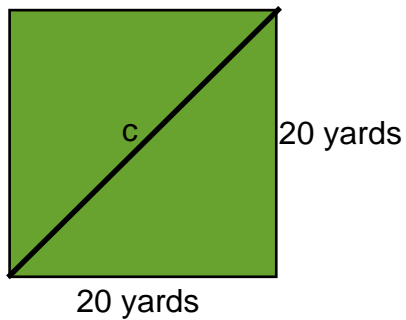

$$a^2 + b^2 = c^2$$

$$20^2 + 20^2 = c^2$$

$$400 + 400 = c^2$$

$$800 = c^2$$

$$\sqrt{800} = \sqrt{c^2}$$

$$c \approx 28.2843$$

The distance to walk around the two joining sides is $20\text{yds} + 20\text{yds} = 40\text{yds}$. The distance to walk the diagonal is 28.2843yds . The difference is $40 - 28.2843 = 11.7157$.

It is approximately 11.7157 yards less to walk the diagonal.

34.

$$y = \frac{1}{6}x - 5$$

$$-\frac{1}{6}x + y = -5$$

35.

$$-2 = \sqrt[4]{x+7}$$

$$(-2)^4 = (\sqrt[4]{x+7})^4$$

$$16 = x+7$$

$$9 = x$$

36.

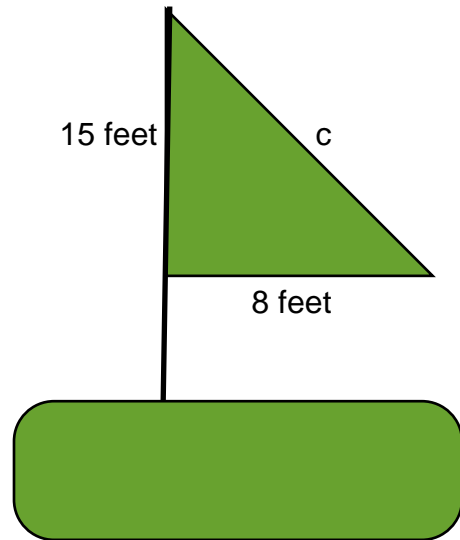

The diagonal of the sail is 17 feet.

$$a^2 + b^2 = c^2$$

$$15^2 + 8^2 = c^2$$

$$225 + 64 = c^2$$

$$289 = c^2$$

$$\sqrt{289} = \sqrt{c^2}$$

$$c = 17$$

37.

$$\frac{2}{\sqrt{2}} * \frac{\sqrt{2}}{\sqrt{2}} = \frac{2\sqrt{2}}{2} = \sqrt{2}$$

Lesson 11.7

Stem and Leaf Plots and Histograms

1. The stem in a stem and leaf plot is the left hand column and lists the digits in the largest place. The leaf in a stem and leaf plot is the right hand column and lists the digits in the smallest place. The advantage to using a stem and leaf plot is that the chart quickly provides information from and about the data. It is also an easy method for sorting numbers manually.

2. A histogram is a bar chart that describes frequency distribution (the number of times a particular category appears in a data set). A histogram allows you to quickly determine information about the data set, such as total number of entries, highest frequency, and lowest frequency.

3.

1. A histogram would allow you take the large number of entries (100) and compare them quickly. A histogram would tell you in a look what the most popular drinks were (important for future ordering or stocking enough) and if any soft drinks were not chosen at all (so money would not be wasted buying these again.)

2. A histogram of this information would help the teacher determine what would be the appropriate amount of time to allot for a similar assignment. You would be able to quickly tell what amount of time it took most of the students (largest bar and any close to it). If many students were on the longer end of time the teacher knows this assignment needs more time, and if many students are on the very short end of the time scale the teacher knows that this is a quick assignment. In addition it would allow the teacher to many students take longer and might need extra help.

3. A histogram would allow the planners and builders of the mall to determine how far is too far (if few or no people parked in the spaces that distance away) and what is the ideal distance.

4.

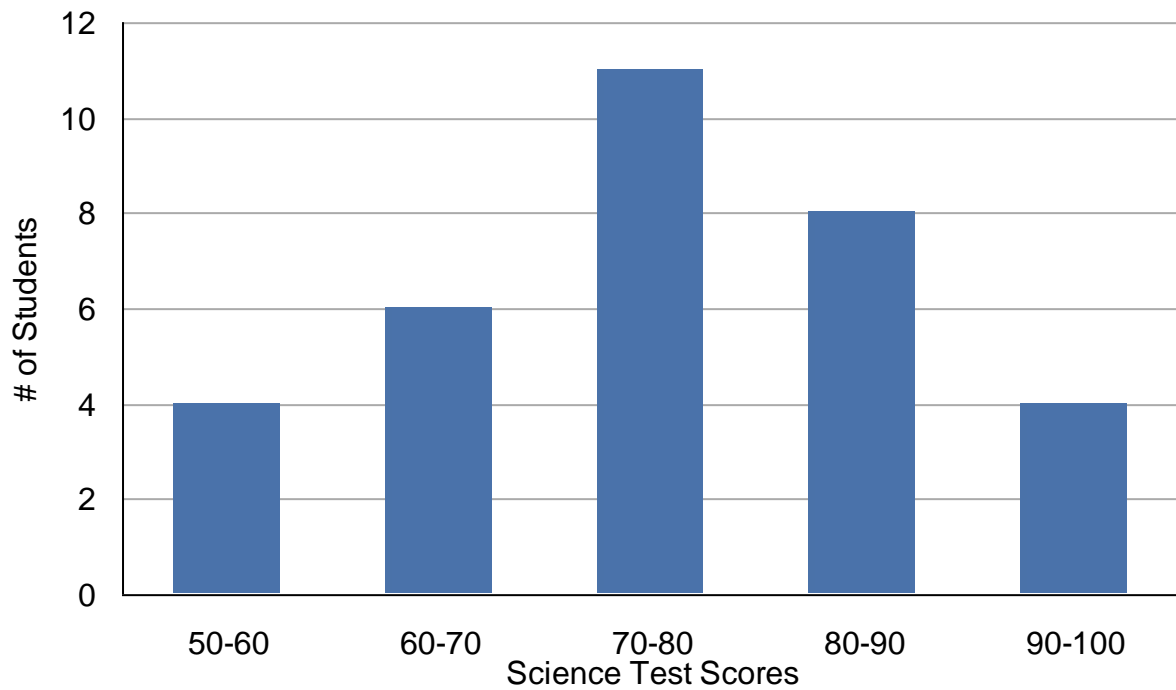

Possible conclusions would be:

The total # of students is 33.

The greatest number of students scored between 70 and 80.

The least number of students scored between 90 and 110 or between 50 and 60.

The scores almost form a typical bell curve.

The range is 50 points.

The mean score is between 70 and 80.

The median score is between 70 and 80.

The mode is between 70 and 80.

(as well as any other data that can be observed or inferred from the histogram)

5.

1.

Stem	Leaf
8	7,9
9	4
10	0
11	8
12	2,3
13	1,7,8
14	1,3,4
15	9
16	3,4,4,5,8
17	5
18	---
19	3
20	4
21	7,9
22	0,6
23	---
24	8,8
25	0
26	6

2. There were 30 chain stores involved in selling the streak-free glass cleaner.

3. The number 11 represents 110 and the number 8 represents 80.

4. 19 out of the 33 stores sold less than 175 bottles. Approximately 58% of the stores sold less than 175 bottles.

6.

A.

Stem	Leaf
6	1,7
7	2,4,4,6,6,7,7,8,9
8	1,1,2,2,2,2,4,5,5,5,6,7,7,8,8,9,9
9	0,0,1,4,4,5,5,5,6,7,9,9

a. Mean = 84.725

b. Mode = 82

c. Median = 85

B.

Number	Tally	Frequency
600-649	I	1
650-699	I	1
700-749	III	3
750-799	IIIIII	6
800-849	IIIIIIII	8
850-899	IIIIIIIIII	10
900-949	IIIII	5
950-999	IIIIII	6

C.

a. bin width of 50

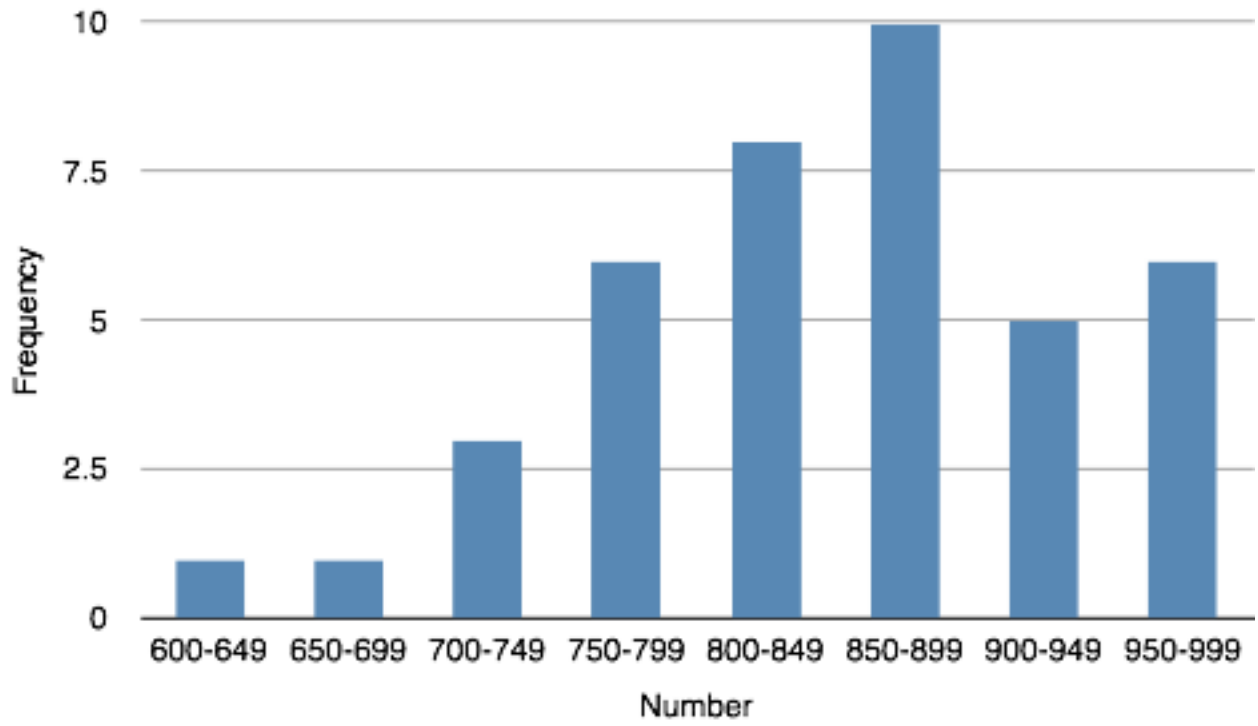

b. bin width of 100

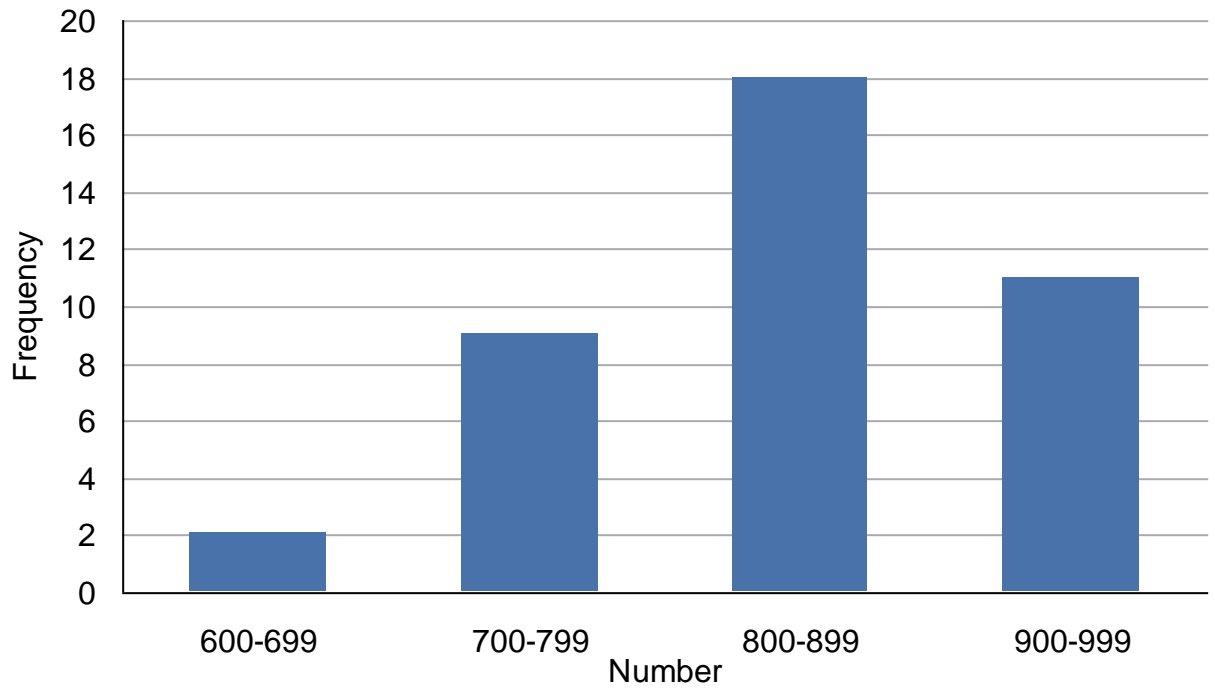

7.

Stem	Leaf
5	0,7,9
6	1,1,2,2,4,5,5,5,7,8,9
7	0,0,1,3,6,7,7,9,9
8	0,0,0,2,2,3,7

8.

Stem	Leaf
1	2, 3
2	1,7
3	3,4,5,7
4	0,0,1

Possible Conclusions:

- The little boy is likely getting more confident (or more afraid).
- The little swimmer does best at just over half an hour in the war.
- They went to the pool 11 days.
- The range is 29 minutes
- The mean time is about 30 minutes.
- The median time is 34 minutes.
- The mode is 40 minutes.

9.

1. Mean= 36.9

Median= 35.5

Mode= 32

2.

Speed in MPH	Frequency
25-29	5
30-34	12
35-39	10
40-44	7
45-49	4
50-54	1
55-59	1

3.

Cars Traveling in a 35MPH Zone

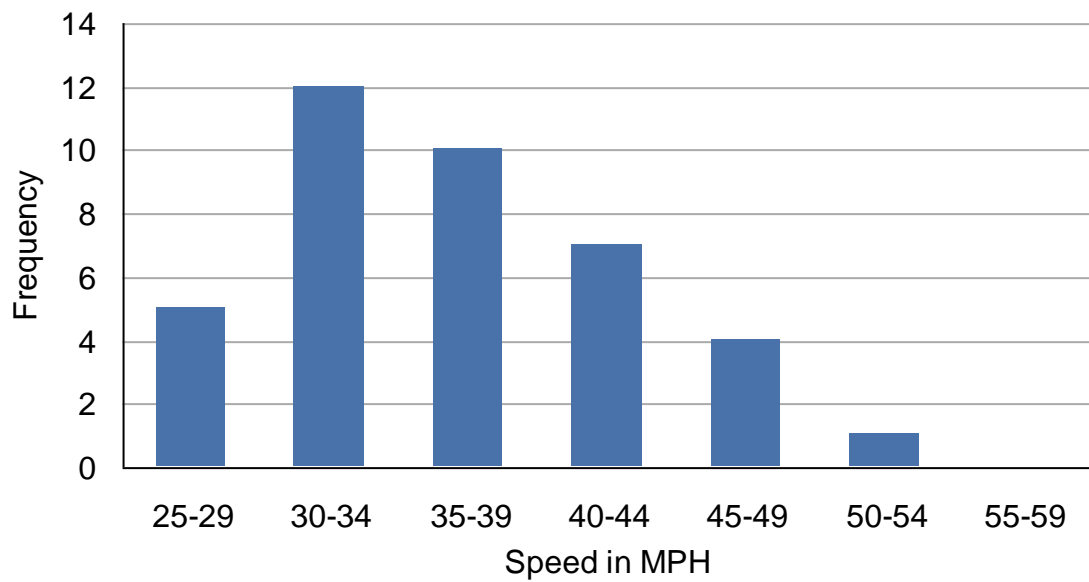

10.

1. Median = 2
2. Mean = 2.5679
3. Mode = 2
4. Odd # of Siblings = 38
5. (# of people with ≥ 4 siblings = 20) % of people with ≥ 4 siblings = 24.69%

11. Answers will vary. Any situation that adequately fits the data (has 4 entries of the correct numbers) is correct.

12.

Regular Gasoline	
Stem	Leaf
50	
51	
52	
53	
54	0
55	0,5
56	
57	0,0
58	0,5,7,8
59	0,1
60	
61	0,5
62	
63	
64	0
65	
66	0
67	
68	
69	
70	

Premium Gasoline	
Stem	Leaf
50	0
51	
52	
53	
54	
55	
56	
57	
58	9
59	
60	
61	8,9
62	9
63	3,5,7,8,9
64	
65	9
66	4
67	
68	9
69	4
70	9

Mixed Review

13.

The soccer team consists of nine players. If the goalie has to be in the center there are 8 places left for the other 8 players to stand in.

As the order in which the players are standing is relevant when the photograph is being taken, the problem involves the use of permutation.

The required number of ways is

$$P(8,8) = \frac{8!}{(8-8)!} = \frac{8!}{1} = 8! = 40320$$

A nine member soccer team can line up in 40320 ways for a photograph if the goalie is in the center.

14.

x-intercept = (5,0)

y-intercept = (0,8)

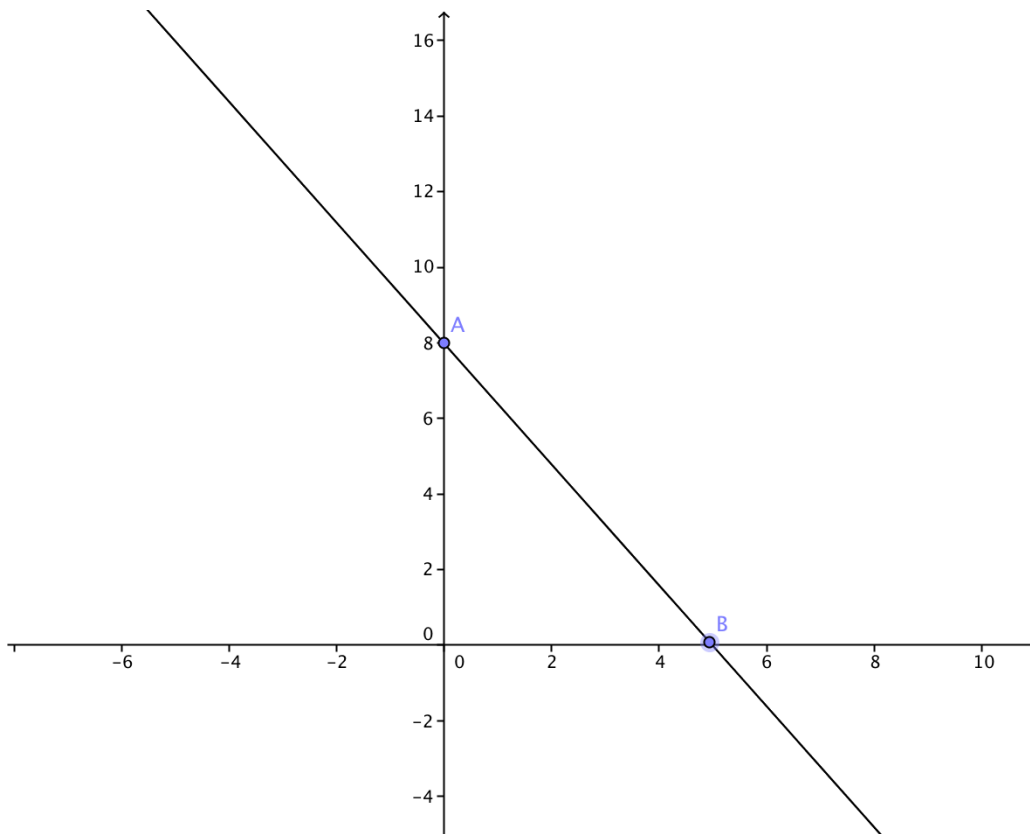

15.

$$\begin{aligned}\left(\frac{7y^{-3}z^2}{4y^4z^{-6}}\right)^{-2} &= \left(\frac{7}{4} * \frac{y^{-3}}{y^4} * \frac{z^2}{z^{-6}}\right)^{-2} = \\ \left(\frac{7}{4} * y^{(-3)-4} * z^{2-(-6)}\right)^{-2} &= \left(\frac{7}{4} * y^{-7} * z^8\right)^{-2} = \\ \left(\frac{7z^8}{4y^7}\right)^{-2} &= \left(\frac{7^{1(-2)} * z^{8(-2)}}{4^{1(-2)} * y^{7(-2)}}\right) = \left(\frac{7^{-2} * z^{-16}}{4^{-2} * y^{-14}}\right) = \frac{16y^{14}}{49z^{16}}\end{aligned}$$

16.

$$y = -3(x-1)^2 + 4$$

$$y = -3(x^2 - x - x + 1) + 4$$

$$y = -3(x^2 - 2x + 1) + 4$$

$$y = -3x^2 + 6x - 3 + 4$$

$$y = -3x^2 + 6x + 1$$

17. $f(x) = \frac{-x+2}{2}$

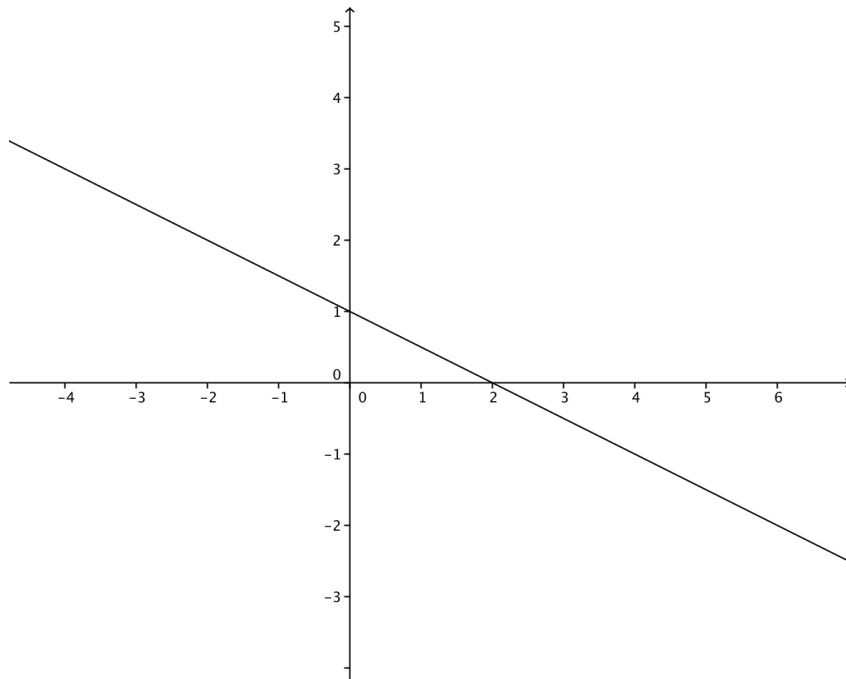

18.

$$h(t) = -\frac{1}{2}(g)t^2 + v_0t + h_0$$

$$h(t) = -\frac{1}{2}(9.8)t^2 + (0)t + 10$$

$$h(t) = -4.9t^2 + 10$$

$$0 = -4.9t^2 + 10$$

$$-10 = -4.9t^2$$

$$2.0408 \approx t^2$$

$$\sqrt{2.0408} \approx \sqrt{t^2}$$

$$t \approx 1.4286$$

The ball will reach the ground at approximately 1.4286 seconds.

19.

$$\begin{cases} 3x + 4y = 9 \\ 9x + 12y = 27 \end{cases}$$

$$-3(3x + 4y = 9) \rightarrow -9x - 12y = -27$$

$$9x + 12y = 27$$

$$\underline{-9x - 12y = -27}$$

$$0 = 0$$

This system is consistent-dependent and has an infinite number of solutions.

Lesson 11.8
Box and Whisker Plots

1. The five-number summary are the numbers needed to construct a box-and-whisker plot: the minimum value, the lower quartile median (Q_1), the median, the upper quartile median (Q_2), and the maximum value.
2. The purpose of a box-and-whisker plot is to display data. It shows how the data are dispersed around a median, without showing specific values. It is often used when the number of data values is large or when two or more data sets are being compared.
3. A disadvantage of representing data with a box-and-whisker plot is that it does not show distribution in as much detail as a stem-and-leaf plot or a histogram. It does not show any specific data values.

4.
25, 28, 34, 35, 35, 35, 40, 40, 42, 47,
49, 50, 50, 50, 50, 55, 55, 58, 60, 60,
64, 65, 70, 70, 70, 75, 75, 80, 80, 80,
84, 85, 90, 90, 93, 95, 95, 100, 110, 120

Minimum = 25

Q_1 = 48

Median = 62

Q_3 = 84

Maximum = 120

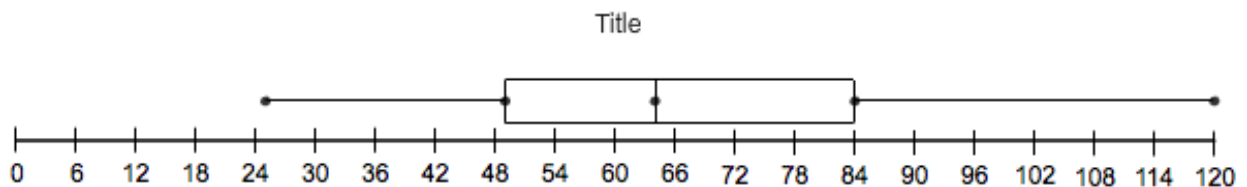

- 5.
- (a) If the pass mark is 65% then 20 students would be allow in the class.
 - (b) If the pass mark is 60% then 10 students would be allow in the class.

6.

5,6,6,7,7,7,8,8,8,8,
8,9,9,9,9,9,10,10,10,10,
10,10,10,10,10,11,11,11,11,12,
12,12,12,12,12,12,12,12,13,13,
13,13,14,14,14,15,15,15,17,17

Minimum = 5

Q_1 = 9

Median = 10.5

Q_3 = 12

Maximum = 17

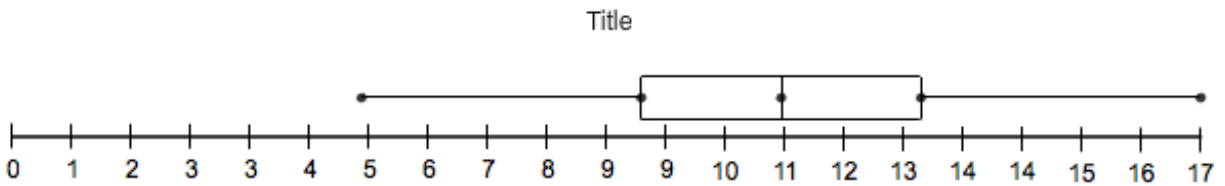

Range = 12

Interquartile Range = 4

7.

Girls

Minimum = 1.7

Q_1 = 2.5

Median = 2.9

Q_3 = 3.3

Maximum = 4.2

The girls have a higher median and their lower 50% is higher than the boys' lower 50%.

Boys

Minimum = 1.5

Q_1 = 2

Median = 2.5

Q_3 = 3.5

Maximum = 5.2

The boys have a higher maximum and their higher 50% is greater than the girls' higher 50%.

8.

49, 49, 49, 50, 50, 51, 52, 53, 53, 54,
56, 57, 57, 57, 58, 59, 67

Minimum = 49

Q_1 = 50

Median = 53

Q_3 = 57

Maximum = 67

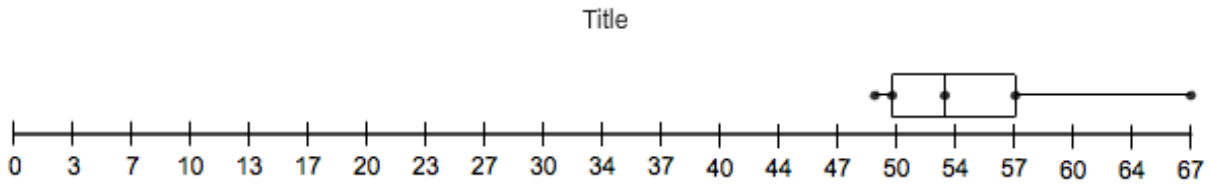

9.

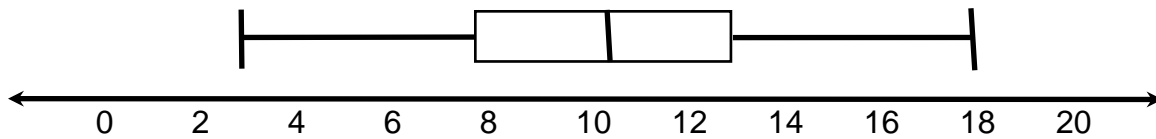

10.

Texas

Minimum = 5

Q_1 = 13

Median = 16

Q_3 = 19.5

Maximum = 35

This data has a large number of outliers. It is harder to make conclusions when this is true.

The interquartile range is higher than in California.

California

Minimum = 6

Q_1 = 9.5

Median = 12

Q_3 = 15.5

Maximum = 22

This data is more centered. The distribution is smaller. The interquartile range and the maximum are lower than Texas, although the minimum is higher.

11. First we must compute the interquartile range (IQR) and determine what the minimums for outliers are

$$IQR = Q_3 - Q_1$$

$$Q_3 = 68$$

$$Q_1 = 39$$

$$68 - 39 = 29$$

$$\text{Outlier} = 1.5 * IQR$$

$$IQR = 29$$

$$1.5 * 29 = 43.5$$

Based on this we know that any point 43.5 units less than 39 (Q_1) or 43.5 units more than 68 (Q_3) is an outlier. Looking at the choices:

(a) 78 is only 10 degrees more than 68: NOT an outlier

(b) -8 is 47 degrees less than 39: OUTLIER

(c) 94 is only 26 degrees more than 68: NOT an outlier

(d) 106 is only 3 degrees more than 68: NOT an outlier.

The answer is b.

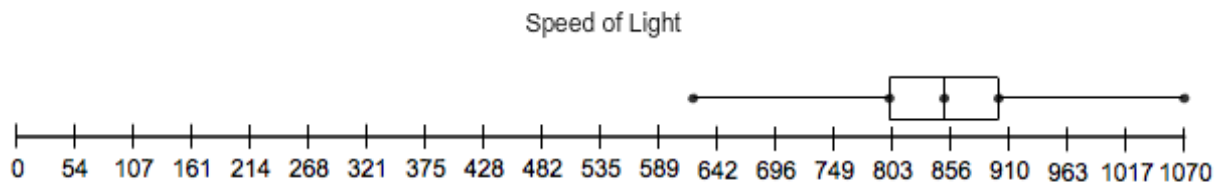

12.

13.

Possible Answers:

The median of the data is 134.

The minimum is 100.

The maximum is 195.

25% of the values fall between 100 and 121.

25% of the values fall between 121 and 134.

25% of the values fall between 134 and 152.

25% of the values fall between 152 and 195.

14.

(a) Males

$$Q_1 = 28$$

$$Q_3 = 68 \text{ Between } \$28 \text{ and } \$68.$$

Females

$$Q_1 = 22$$

$$Q_3 = 58 \text{ Between } \$22 \text{ and } \$58$$

(b) \$42 for males and \$46 for females are the median of each data set.

(c) The middle 50% of males spent more on school lunches than the middle 50% of females. The males spent more overall on lunch than the females.

15. Choice 2

Mixed Review

16.

Mean = average = \bar{x}

$$\bar{x} = \frac{63450 + 45502 + 63450 + 51769 + 63450 + 35120 + 45502 + 63450 + 31100 + 42216 + 49108 + 63450 + 37904}{13}$$

$$\bar{x} = \frac{655471}{13}$$

$$\bar{x} = 50420.85$$

Median = middle#

Median = 31100, 35120, 37904, 42216, 45502, 45502, (49108), 51769, 63450, 63450, 63450, 63450, 63450

Median = 49108

Mode = # appears >

Mode = 31100, 35120, 37904, 42216, 45502, 45502, 49108, 51769, 63450, 63450, 63450, 63450, 63450

Mode = 63450

Range = greatest – least

Range = 63450 – 31100

Range = 32350

The mean is \$50,420.85

The median is \$49,108

The mode is \$63,450

The range is \$32,350

17. $g(x) = 2\sqrt{x-1} - 3$

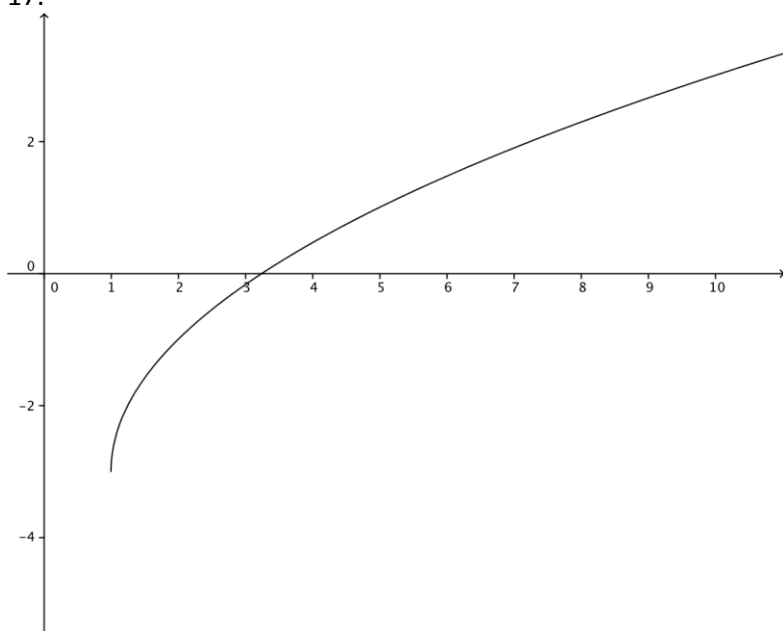

18. $\sqrt{x+6} > 18$

19.

$$6(y-11)+9 = \frac{1}{3}(27+3y)-16$$

$$6y - 66 + 9 = 9 + y - 16$$

$$6y - 57 = y - 7$$

$$5y = 50$$

$$y = 10$$

Check :

$$6(y-11)+9 = \frac{1}{3}(27+3y)-16$$

$$6(10-11)+9 = \frac{1}{3}(27+3(10))-16$$

$$6(-1)+9 = \frac{1}{3}(57)-16$$

$$-6+9 = 19-16$$

$$3 = 3$$

20.

(a)

$$\text{pizza} = p$$

$$\text{cookiedough} = c$$

$$5p + 4c > 550$$

(b)

5p and 4c must each be set equal to values that add up to some number greater than 550, and these values must be evenly divisible by 5 (for p) and 4 (for c).

For example, set 5p=300 and 4c=300, so that p=60 and c=75. 5p + 4c will then equal 600 (which is >550).

Select other values for 5P and 4C that meet the requirements (evenly divisible by the respective coefficients and having a sum > 550).

21.

$$x + 2y = 10$$

$$2y = -x + 10$$

$$y = -\frac{1}{2}x + 5$$

$$m = -\frac{1}{2}$$

$$\text{point} = (2, 1)$$

$$y - 1 = -\frac{1}{2}(x - 2)$$

Lesson 11.9
Chapter 11 Review

1. This function originates at $(0,7)$ instead of $(0,0)$ and all the y-values are 7 units greater than the values of the parent function.
2. This function originates at $(-3,0)$ instead of $(0,0)$ and all the x-values are 3 units less than the values of the parent function.
3. This function is the reflection of the parent function around the x-axis. All the y-values will be the negative of the values of the parent function.
4. This function originates at $(1,3)$ instead of $(0,0)$. All the x-values are 1 unit greater than the values of the parent function and all the y-values are 3 units greater than the values of the parent function.

5. $f(x) = \sqrt{x-2} + 5$

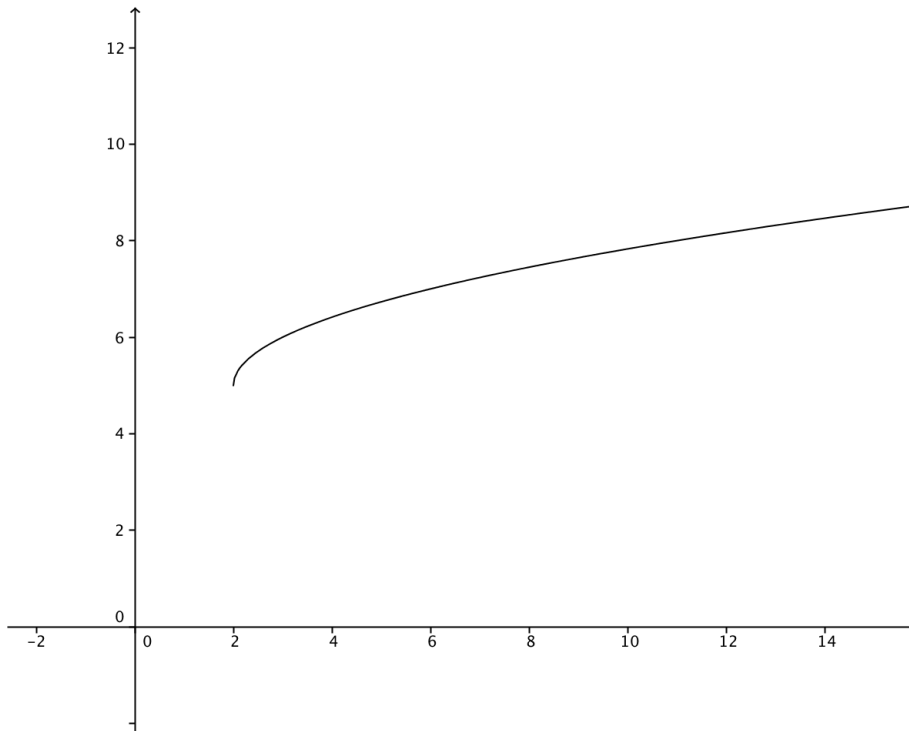

6. $g(x) = -\sqrt{x+1}$

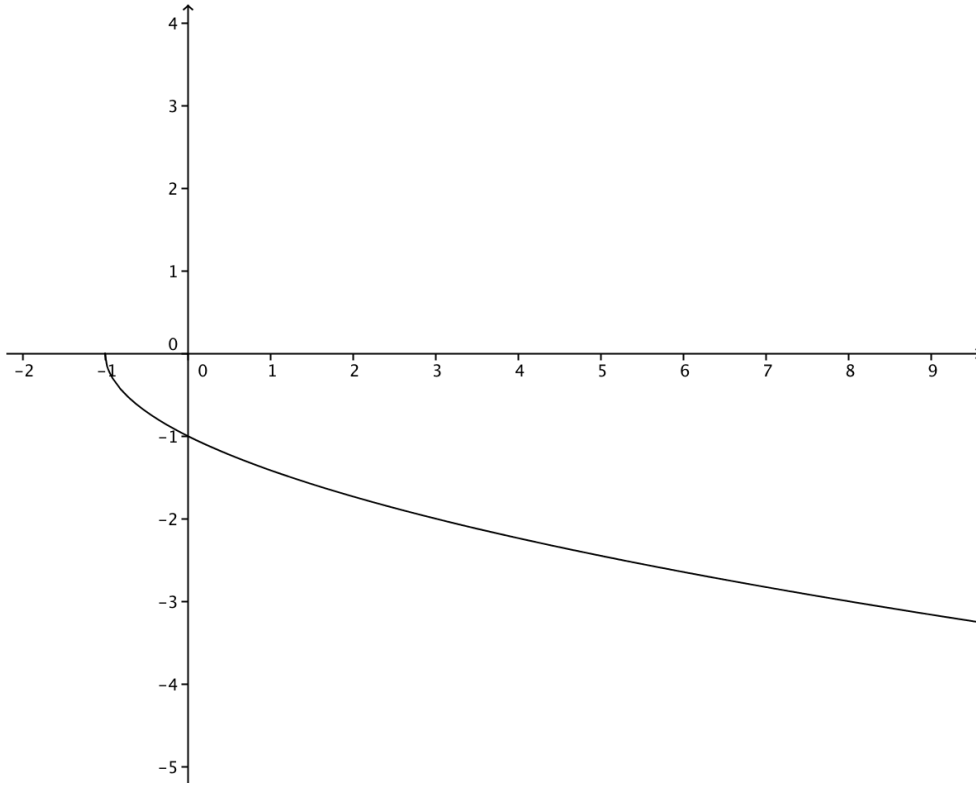

7. $f(x) = \sqrt{2x} - 2$

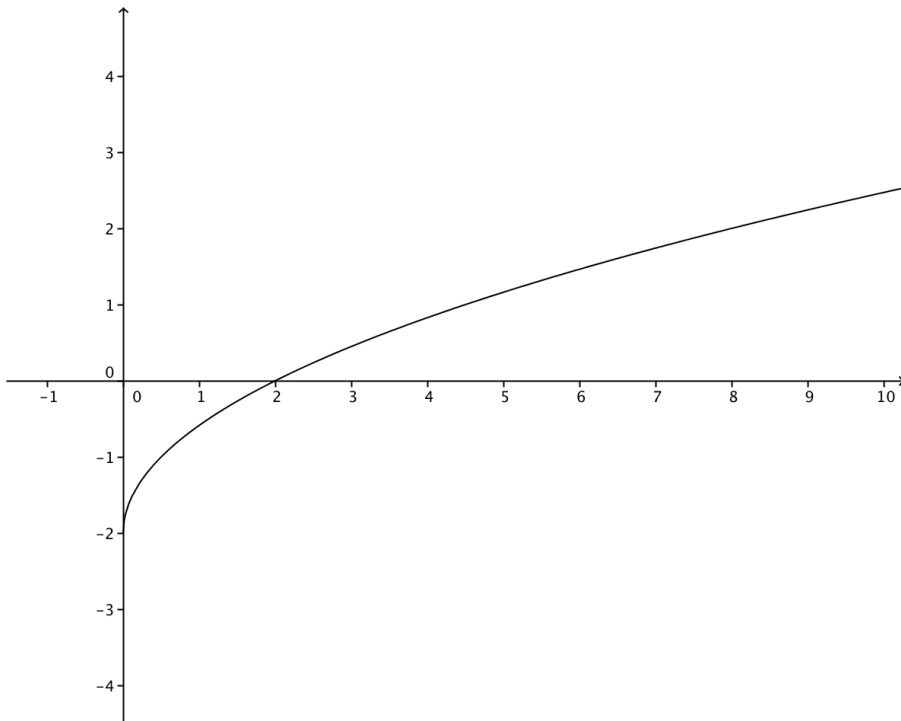

8.

$$\sqrt{\frac{3}{7}} \times \sqrt{\frac{14}{27}} = \sqrt{\frac{3}{7} \times \frac{14}{27}} = \sqrt{\frac{2}{9}}$$

9.

$$\sqrt{5} \cdot \sqrt{7} = \sqrt{35}$$

10.

$$\sqrt{11} \times \sqrt[3]{11} = 11^{\frac{1}{2}} \times 11^{\frac{1}{3}} = 11^{\frac{5}{6}} = \sqrt[6]{11^5} = \sqrt[6]{161051}$$

11.

$$\frac{\sqrt{18}}{\sqrt{2}} = \frac{\sqrt{18}}{\sqrt{2}} * \frac{\sqrt{2}}{\sqrt{2}} = \frac{\sqrt{36}}{2} = \frac{\pm 6}{2} = \pm 3$$

12.

$$8\sqrt[3]{4} + 11\sqrt[3]{4} = (8+11)\sqrt[3]{4} = 19\sqrt[3]{4}$$

13.

$$5\sqrt{80} - 12\sqrt{5}$$

$$5 \cdot \sqrt{16} \cdot \sqrt{5} - 12\sqrt{5}$$

$$\pm 20\sqrt{5} - 12\sqrt{5}$$

$$20\sqrt{5} - 12\sqrt{5} = 8\sqrt{5}$$

$$-20\sqrt{5} - 12\sqrt{5} = -32\sqrt{5}$$

14.

$$\sqrt{10} + \sqrt{2} = \sqrt{5} \cdot \sqrt{2} + \sqrt{2} = (1 + \sqrt{5})\sqrt{2}$$

15.

$$\sqrt{24} - \sqrt{6} = \sqrt{4} \cdot \sqrt{6} - \sqrt{6} = 2\sqrt{6} - \sqrt{6} = \sqrt{6}$$

16.

$$\sqrt[3]{27} + \sqrt[4]{81} = 3 + 3 = 6$$

17.

$$4\sqrt{3} \cdot 2\sqrt{6} = 8\sqrt{18}$$

18.

$$\sqrt[3]{3} \times \sqrt{7}$$

Cannot be simplified

19.

$$6\sqrt{72} = 6 \cdot \sqrt{36} \cdot \sqrt{2} = 6 \cdot \pm 6 \cdot \sqrt{2} = \pm 36\sqrt{2}$$

20.

$$7\sqrt{\left(\frac{40}{49}\right)} = 7 \cdot \frac{\sqrt{40}}{\sqrt{49}} = 7 \cdot \frac{\sqrt{40}}{\pm 7} = \pm\sqrt{40} = \pm(\sqrt{4} \cdot \sqrt{10}) = \pm 2\sqrt{10}$$

21.

$$\frac{5}{\sqrt{75}} = \frac{5}{\sqrt{75}} * \frac{\sqrt{75}}{\sqrt{75}} = \frac{5\sqrt{75}}{75} = \frac{\sqrt{75}}{15} = \frac{\sqrt{3} \cdot \sqrt{25}}{15} = \frac{\pm 5\sqrt{3}}{15} = \frac{\pm\sqrt{3}}{3}$$

22.

$$\frac{\sqrt{45}}{\sqrt{5}} = \frac{\sqrt{45}}{\sqrt{5}} * \frac{\sqrt{5}}{\sqrt{5}} = \frac{\sqrt{225}}{5} = \frac{\pm 15}{5} = \pm 3$$

23.

$$\frac{3}{\sqrt[3]{3}} = \frac{3}{\sqrt[3]{3}} * \frac{\sqrt[3]{3^2}}{\sqrt[3]{3^2}} = \frac{3 \cdot \sqrt[3]{3^2}}{3} = \sqrt[3]{3^2} = \sqrt[3]{9}$$

24.

$$8\sqrt{10} - 3\sqrt{40}$$

$$8\sqrt{10} - (3 \cdot \sqrt{4} \cdot \sqrt{10})$$

$$8\sqrt{10} - (3 \cdot \pm 2 \cdot \sqrt{10})$$

$$8\sqrt{10} - \pm 6\sqrt{10}$$

$$8\sqrt{10} - 6\sqrt{10} = (8 - 6)\sqrt{10} = 2\sqrt{10}$$

$$8\sqrt{10} - (-6)\sqrt{10} = (8 + 6)\sqrt{10} = 14\sqrt{10}$$

25.

$$\sqrt{27} + \sqrt{3}$$

$$(\sqrt{9} \cdot \sqrt{3}) + \sqrt{3}$$

$$\pm 3\sqrt{3} + \sqrt{3}$$

$$3\sqrt{3} + \sqrt{3} = 4\sqrt{3}$$

$$-3\sqrt{3} + \sqrt{3} = -2\sqrt{3}$$

26.

$$8 = \sqrt[3]{2k}$$

$$8^3 = (\sqrt[3]{2k})^3$$

$$512 = 2k$$

$$k = 256$$

Check

$$8 = \sqrt[3]{2k}$$

$$8 = \sqrt[3]{2(256)}$$

$$8 = \sqrt[3]{512}$$

$$8 = 8$$

27.

$$x = \sqrt{7x}$$

$$x^2 = (\sqrt{7x})^2$$

$$x^2 = 7x$$

$$x^2 - 7x = 0$$

$$x^2 - 7x + 12.25 = 12.25$$

$$(x - 3.5)^2 = 12.25$$

$$\sqrt{(x - 3.5)^2} = \sqrt{12.25}$$

$$x - 3.5 = \pm 3.5$$

$$x = 7$$

$$x = 0$$

Check

$$x = \sqrt{7x}$$

$$(7) = \sqrt{7(7)}$$

$$7 = \sqrt{49}$$

$$7 = 7$$

$$x = \sqrt{7x}$$

$$0 = \sqrt{7(0)}$$

$$0 = 0$$

28.

$$\sqrt{2+2m} = \sqrt{4-m}$$

$$\left(\sqrt{2+2m}\right)^2 = \left(\sqrt{4-m}\right)^2$$

$$2+2m = 4-m$$

$$3m = 2$$

$$m = \frac{2}{3}$$

Check

$$\sqrt{2+2m} = \sqrt{4-m}$$

$$\sqrt{2+2\left(\frac{2}{3}\right)} = \sqrt{4-\left(\frac{2}{3}\right)}$$

$$\sqrt{2+\frac{4}{3}} = \sqrt{4-\left(\frac{2}{3}\right)}$$

$$\sqrt{\frac{10}{3}} = \sqrt{\frac{10}{3}}$$

29.

$$\sqrt[4]{35-2x} = -1$$

$$\left(\sqrt[4]{35-2x}\right)^4 = (-1)^4$$

$$35-2x = 1$$

$$-2x = -34$$

$$2x = 34$$

$$x = 17$$

Check

$$\sqrt[4]{35-2x} = -1$$

$$\sqrt[4]{35-2(17)} = -1$$

$$\sqrt[4]{35-34} = -1$$

$$\sqrt[4]{1} = -1$$

$$-1 = -1$$

30.

$$14 = 6 + \sqrt{10 - 6x}$$

$$8 = \sqrt{10 - 6x}$$

$$8^2 = (\sqrt{10 - 6x})^2$$

$$64 = 10 - 6x$$

$$54 = -6x$$

$$x = -9$$

Check

$$14 = 6 + \sqrt{10 - 6x}$$

$$14 = 6 + \sqrt{10 - 6(-9)}$$

$$14 = 6 + \sqrt{10 + 54}$$

$$14 = 6 + \sqrt{64}$$

$$14 = 6 + 8$$

$$14 = 14$$

31.

$$4 + \sqrt{\frac{n}{3}} = 5$$

$$\sqrt{\frac{n}{3}} = 1$$

$$\left(\sqrt{\frac{n}{3}}\right)^2 = 1^2$$

$$\frac{n}{3} = 1$$

$$n = 3$$

Check

$$4 + \sqrt{\frac{n}{3}} = 5$$

$$4 + \sqrt{\frac{3}{3}} = 5$$

$$4 + \sqrt{1} = 5$$

$$4 + 1 = 5$$

$$5 = 5$$

32.

$$\sqrt{-9-2x} = \sqrt{-1-x}$$

$$\left(\sqrt{-9-2x}\right)^2 = \left(\sqrt{-1-x}\right)^2$$

$$-9-2x = -1-x$$

$$-x = 8$$

$$x = -8$$

Check

$$\sqrt{-9-2x} = \sqrt{-1-x}$$

$$\sqrt{-9-2(-8)} = \sqrt{-1-(-8)}$$

$$\sqrt{-9+16} = \sqrt{7}$$

$$\sqrt{7} = \sqrt{7}$$

33.

$$-2 = \sqrt[3]{t-6}$$

$$(-2)^3 = \left(\sqrt[3]{t-6}\right)^3$$

$$-8 = t-6$$

$$t = -2$$

Check

$$-2 = \sqrt[3]{t-6}$$

$$-2 = \sqrt[3]{(-2)-6}$$

$$-2 = \sqrt[3]{-8}$$

$$-2 = -2$$

34.

$$5\sqrt{10} = 6\sqrt{w}$$

$$(5\sqrt{10})^2 = (6\sqrt{w})^2$$

$$25 * 10 = 36w$$

$$250 = 36w$$

$$w \approx 6.9444$$

Check

$$5\sqrt{10} = 6\sqrt{w}$$

$$5\sqrt{10} = 6\sqrt{6.9444}$$

$$5 * 3.1623 = 6 * 2.6352$$

$$15.8115 \approx 15.8112$$

35.

$$\sqrt{x^2 + 3x} = 2$$

$$\left(\sqrt{x^2 + 3x}\right)^2 = 2^2$$

$$x^2 + 3x = 4$$

$$x^2 + 3x + 2.25 = 4 + 2.25$$

$$(x + 1.5)^2 = 6.25$$

$$\sqrt{(x + 1.5)^2} = \sqrt{6.25}$$

$$x + 1.5 = \pm 2.5$$

$$x + 1.5 = 2.5$$

$$x = 1$$

$$x + 1.5 = -2.5$$

$$x = -4$$

Check

$$\sqrt{x^2 + 3x} = 2$$

$$\sqrt{1^2 + 3(1)} = 2$$

$$\sqrt{1 + 3} = 2$$

$$\sqrt{4} = 2$$

$$2 = 2$$

$$\sqrt{x^2 + 3x} = 2$$

$$\sqrt{(-4)^2 + 3(-4)} = 2$$

$$\sqrt{16 - 12} = 2$$

$$\sqrt{4} = 2$$

$$2 = 2$$

36.

$$\sqrt[4]{t} = 5$$

$$(\sqrt[4]{t})^4 = 5^4$$

$$t = 625$$

Check

$$\sqrt[4]{t} = 5$$

$$\sqrt[4]{625} = 5$$

$$5 = 5$$

37.

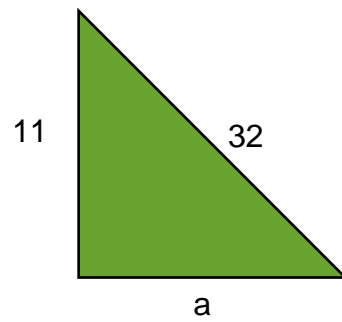

$$a^2 + b^2 = c^2$$

$$a^2 + 11^2 = 32^2$$

$$a^2 + 121 = 1024$$

$$a^2 = 903$$

$$a = \sqrt{903}$$

$$a \approx 30.05$$

38.

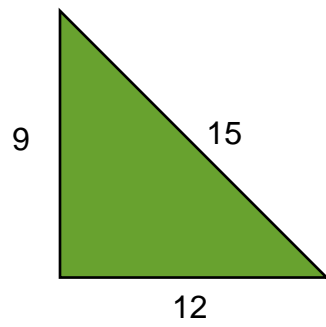

$$a^2 + b^2 = c^2$$

$$9^2 + 12^2 = 15^2$$

$$81 + 144 = 225$$

$$225 = 225$$

Yes 9,12, 15 is a right triangle.

(Also 9,12,15 is a version of a 3,4,5 right triangle.)

39.

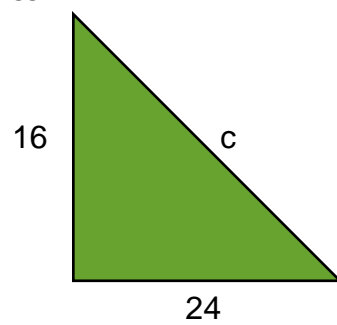

$$a^2 + b^2 = c^2$$

$$16^2 + 24^2 = c^2$$

$$256 + 576 = c^2$$

$$c^2 = 832$$

$$c = \sqrt{832}$$

$$c \approx 28.8444$$

40.

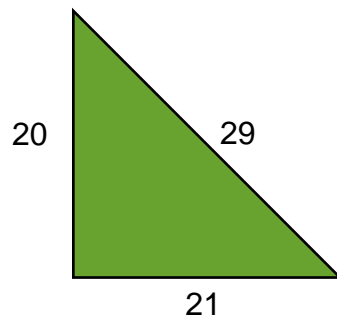

$$a^2 + b^2 = c^2$$

$$20^2 + 21^2 = 29^2$$

$$400 + 441 = 841$$

$$841 = 841$$

Yes 20,21,29 is a right triangle.

41.

$(0,2)$ & $(-5,4)$

$$d = \sqrt{(y_2 - y_1)^2 + (x_2 - x_1)^2}$$

$$d = \sqrt{(4 - 2)^2 + (-5 - 0)^2}$$

$$d = \sqrt{2^2 + (-5)^2}$$

$$d = \sqrt{4 + 25}$$

$$d = \sqrt{29}$$

$$(x_m, y_m) = \left(\frac{x_1 + x_2}{2}, \frac{y_1 + y_2}{2} \right)$$

$$(x_m, y_m) = \left(\frac{0 + (-5)}{2}, \frac{2 + 4}{2} \right)$$

$$(x_m, y_m) = \left(\frac{-5}{2}, \frac{6}{2} \right)$$

$$(x_m, y_m) = (-2.5, 3)$$

42.

$(7, -3) \& (4, -3)$

$$d = \sqrt{(y_2 - y_1)^2 + (x_2 - x_1)^2}$$

$$d = \sqrt{(-3 - (-3))^2 + (4 - 7)^2}$$

$$d = \sqrt{0^2 + (-3)^2}$$

$$d = \sqrt{0 + 9}$$

$$d = \sqrt{9}$$

$$d = 3$$

$$(x_m, y_m) = \frac{(x_1 + x_2)}{2}, \frac{(y_1 + y_2)}{2}$$

$$(x_m, y_m) = \frac{(7 + 4)}{2}, \frac{(-3 + (-3))}{2}$$

$$(x_m, y_m) = \frac{11}{2}, \frac{-6}{2}$$

$$(x_m, y_m) = (5.5, -3)$$

43.

$(4, 6) \& (-3, 0)$

$$d = \sqrt{(y_2 - y_1)^2 + (x_2 - x_1)^2}$$

$$d = \sqrt{(0 - 6)^2 + (-3 - 4)^2}$$

$$d = \sqrt{(-6)^2 + (-7)^2}$$

$$d = \sqrt{36 + 49}$$

$$d = \sqrt{85}$$

$$(x_m, y_m) = \frac{(x_1 + x_2)}{2}, \frac{(y_1 + y_2)}{2}$$

$$(x_m, y_m) = \frac{(4 + (-3))}{2}, \frac{(6 + 0)}{2}$$

$$(x_m, y_m) = \frac{1}{2}, \frac{6}{2}$$

$$(x_m, y_m) = (0.5, 3)$$

44.

$(8, -3) \& (-7, -6)$

$$d = \sqrt{(y_2 - y_1)^2 + (x_2 - x_1)^2}$$

$$d = \sqrt{(-6 - (-3))^2 + (-7 - 8)^2}$$

$$d = \sqrt{(-3)^2 + (-15)^2}$$

$$d = \sqrt{9 + 225}$$

$$d = \sqrt{234}$$

$$d = \sqrt{9} \cdot \sqrt{26}$$

$$d = 3\sqrt{26}$$

$$(x_m, y_m) = \frac{(x_1 + x_2)}{2}, \frac{(y_1 + y_2)}{2}$$

$$(x_m, y_m) = \frac{(8 + (-7))}{2}, \frac{(-3 + (-6))}{2}$$

$$(x_m, y_m) = \frac{1}{2}, \frac{-9}{2}$$

$$(x_m, y_m) = (0.5, -4.5)$$

45.

$$(-8, -7) \& (6, 5)$$

$$d = \sqrt{(y_2 - y_1)^2 + (x_2 - x_1)^2}$$

$$d = \sqrt{(5 - (-7))^2 + (6 - (-8))^2}$$

$$d = \sqrt{(12)^2 + (14)^2}$$

$$d = \sqrt{144 + 196}$$

$$d = \sqrt{340}$$

$$d = \sqrt{4} \cdot \sqrt{85}$$

$$d = 2\sqrt{85}$$

$$(x_m, y_m) = \frac{(x_1 + x_2)}{2}, \frac{(y_1 + y_2)}{2}$$

$$(x_m, y_m) = \frac{(-8 + 6)}{2}, \frac{(-7 + 5)}{2}$$

$$(x_m, y_m) = \frac{-2}{2}, \frac{-2}{2}$$

$$(x_m, y_m) = (-1, -1)$$

46.

$(-6, 6) \& (0, 8)$

$$d = \sqrt{(y_2 - y_1)^2 + (x_2 - x_1)^2}$$

$$d = \sqrt{(8 - 6)^2 + (0 - (-6))^2}$$

$$d = \sqrt{(2)^2 + (6)^2}$$

$$d = \sqrt{4 + 36}$$

$$d = \sqrt{40}$$

$$d = \sqrt{4} \cdot \sqrt{10}$$

$$d = 2\sqrt{10}$$

$$(x_m, y_m) = \frac{(x_1 + x_2)}{2}, \frac{(y_1 + y_2)}{2}$$

$$(x_m, y_m) = \frac{(-6 + 0)}{2}, \frac{(6 + 8)}{2}$$

$$(x_m, y_m) = \frac{-6}{2}, \frac{14}{2}$$

$$(x_m, y_m) = (-3, 7)$$

47.

$$(2, 6)(x, 4)$$

$$d = 6$$

$$d = \sqrt{(y_2 - y_1)^2 + (x_2 - x_1)^2}$$

$$6 = \sqrt{(4 - 6)^2 + (x - 2)^2}$$

$$6 = \sqrt{-2^2 + (x - 2)^2}$$

$$6 = \sqrt{4 + x^2 - 4x + 4}$$

$$6 = \sqrt{x^2 - 4x + 8}$$

$$6^2 = \left(\sqrt{x^2 - 4x + 8}\right)^2$$

$$36 = x^2 - 4x + 8$$

$$28 = x^2 - 4x$$

$$28 + 4 = x^2 - 4x + 4$$

$$32 = (x - 2)^2$$

$$\sqrt{32} = \sqrt{(x - 2)^2}$$

$$\sqrt{32} = x - 2$$

$$x = 2 + \sqrt{32}$$

$$x \approx 2 \pm 5.6569$$

$$x \approx 2 + 5.6569$$

$$x \approx 7.6569$$

$$x \approx 2 - 5.6569$$

$$x \approx -3.6569$$

The two possibilities are approximately (7.6959, 4) and (-3.6959, 4)

48.

$(9,0)(x,3)$

$$d = 5$$

$$d = \sqrt{(y_2 - y_1)^2 + (x_2 - x_1)^2}$$

$$5 = \sqrt{(3 - 0)^2 + (x - 9)^2}$$

$$5 = \sqrt{3^2 + (x - 9)^2}$$

$$5 = \sqrt{9 + x^2 - 18x + 81}$$

$$5 = \sqrt{x^2 - 18x + 90}$$

$$5^2 = \left(\sqrt{x^2 - 18x + 90}\right)^2$$

$$25 = x^2 - 18x + 90$$

$$-65 = x^2 - 18x$$

$$-65 + 81 = x^2 - 18x + 81$$

$$16 = (x - 9)^2$$

$$\sqrt{16} = \sqrt{(x - 9)^2}$$

$$\pm 4 = x - 9$$

$$x = 9 \pm 4$$

$$x = 9 + 4$$

$$x = 13$$

$$x = 9 - 4$$

$$x = 5$$

The two possibilities are $(13,3)$ and $(5,3)$

49.

$$(x_m, y_m) = \frac{(x_1 + x_2)}{2}, \frac{(y_1 + y_2)}{2}$$

$$(7.5, 1.5) = \frac{(-5 + x)}{2}, \frac{(-6 + y)}{2}$$

$$7.5 = \frac{(-5 + x)}{2}$$

$$15 = -5 + x$$

$$20 = x$$

$$1.5 = \frac{(-6 + y)}{2}$$

$$3 = -6 + y$$

$$9 = y$$

The other end of the segment is (20,9)

50.

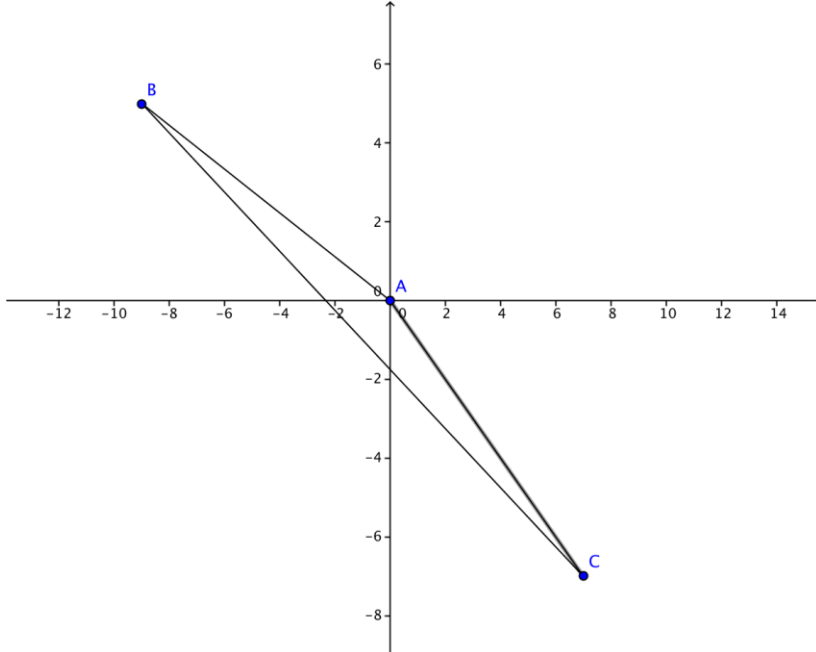

Point A (0,0) is the center of town.

Point B (-9,5) is Maggie's first stop.

Point C (7,-7) is Maggie's final stop.

(7,-7) & (0,0)

$$d = \sqrt{(y_2 - y_1)^2 + (x_2 - x_1)^2}$$

$$d = \sqrt{(0 - (-7))^2 + (0 - 7)^2}$$

$$d = \sqrt{7^2 + (-7)^2}$$

$$d = \sqrt{49 + 49}$$

$$d = \sqrt{98}$$

$$d = \sqrt{49} \cdot \sqrt{2} = 7\sqrt{2}$$

$$(x_m, y_m) = \left(\frac{x_1 + x_2}{2}, \frac{y_1 + y_2}{2} \right)$$

$$(x_m, y_m) = \left(\frac{0 + 7}{2}, \frac{0 + (-7)}{2} \right)$$

$$(x_m, y_m) = \left(\frac{7}{2}, \frac{-7}{2} \right)$$

$$(x_m, y_m) = (3.5, -3.5)$$

51.

$$SA = 6s^2$$

$$337.50 = 6s^2$$

$$56.25 = s^2$$

$$\sqrt{56.25} = \sqrt{s^2}$$

$$s = 7.5$$

52.

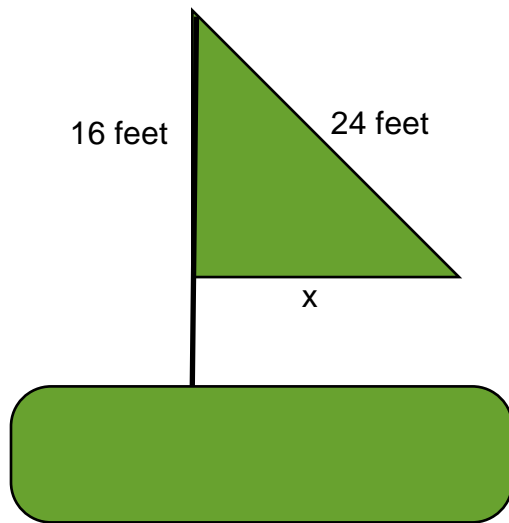

To find the area we need to multiply $1/2$ times 16 feet times x . We will use pythagorean theorem to find x .

$$a^2 + b^2 = c^2$$

$$16^2 + x^2 = 24^2$$

$$256 + x^2 = 576$$

$$x^2 = 320$$

$$x = \sqrt{320}$$

$$x \approx 17.8885$$

$$A = \frac{1}{2}lh$$

$$A = \frac{1}{2}(17.8885)(16)$$

$$A = 143.108$$

The area of the sail is approximately 143.108 square feet.

53.

$$70 = \frac{63 + 65 + 80 + 84 + 73 + x}{6}$$

$$70 = \frac{365 + x}{6}$$

$$420 = 365 + x$$

$$x = 55$$

54.

Mean = \bar{x} = average

$$11 + 12 + 11 + 11 + 11 +$$

$$13 + 13 + 12 + 12 + 11 +$$

$$12 + 13 + 13 + 12 + 13 +$$

$$\bar{x} = \frac{11 + 12 + 12 + 13}{19}$$

$$\bar{x} = \frac{228}{19}$$

$$\bar{x} = 12$$

Median = middle#

$$\text{Med} = 11, 11, 11, 11, 11, 11, 12, 12, 12, (12), 12, 12, 12, 13, 13, 13, 13, 13, 13$$

$$\text{Med} = 12$$

Mode = # appears > times

$$\text{Mode} = 11, 11, 11, 11, 11, 11, 12, 12, 12, 12, 12, 12, 12, 13, 13, 13, 13, 13, 13$$

$$\text{Mode} = 12$$

Range = highest - lowest

$$R = 13 - 11$$

$$R = 2$$

55.

1. Most likely the mean was used to describe this situation.

(Any large value data items raises the mean.)

2. The median should be used to describe this situation.

(The median is more accurate when there are very large or very small data items that don't fit with most of the data.)

56.

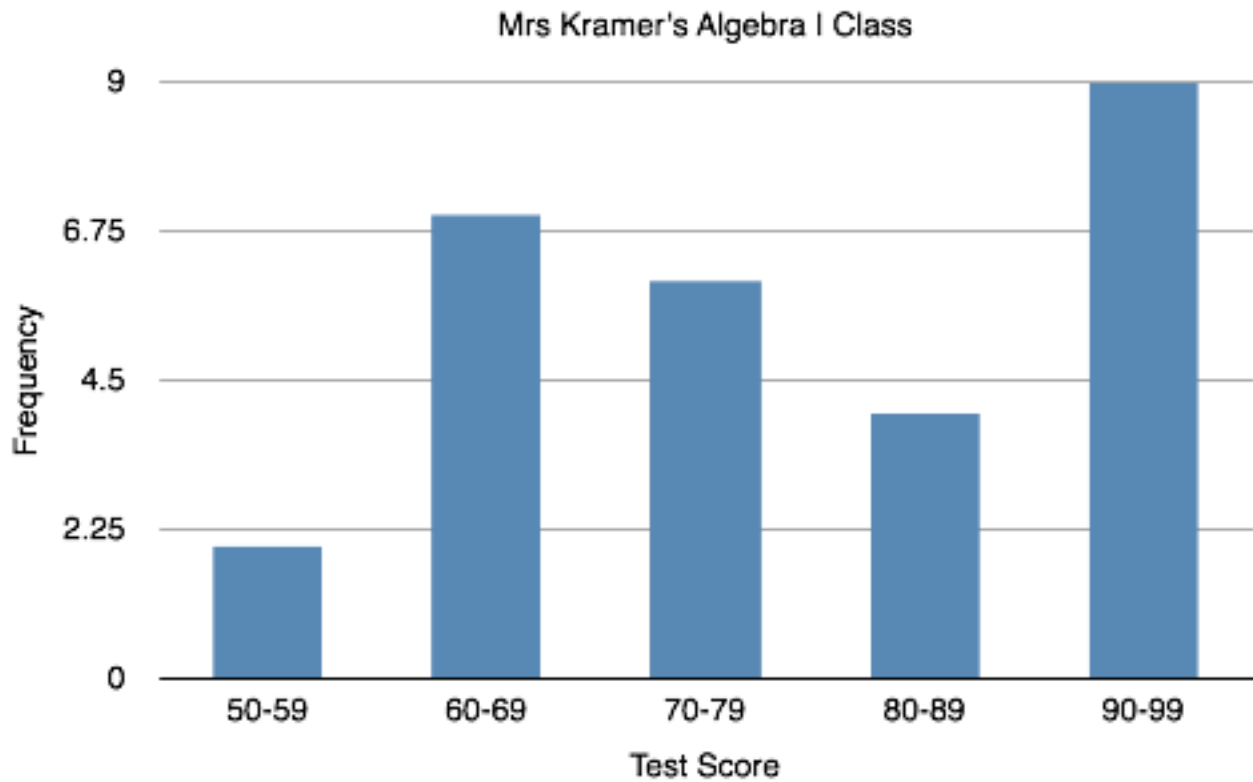

The mode based just on the data is 90. The mode based just on the histogram is 90-99.

From the data we can conclude that more students scored above average on the test than failed.

57.

Tips Earned	
Stem	Leaf
1	7
2	4,7
3	2,8
4	2
5	2,8
6	9
7	3

58.

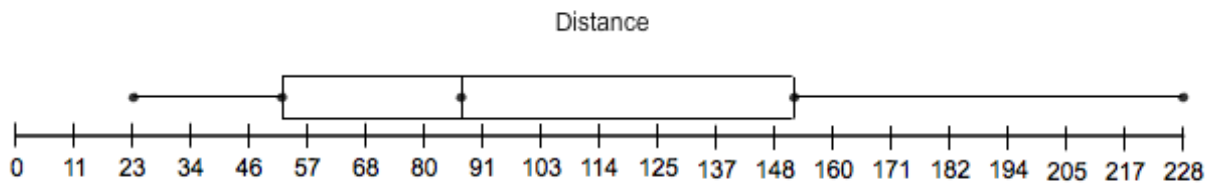

(The number line on this plot has the values multiplied by 10.)

59. Disadvantages to a box-and-whisker plot are that it does not show any specific values for the data, nor does it tell how many values there are in the data.

60.

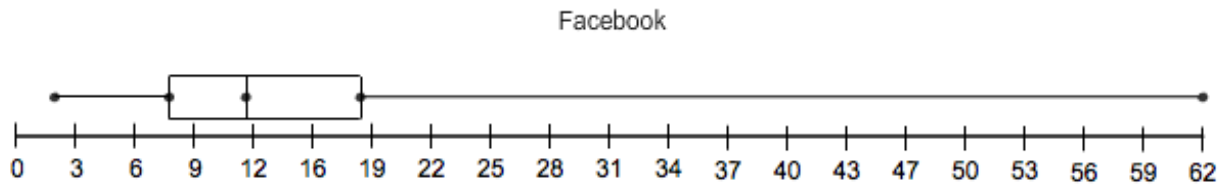

2 and 62 are outliers.

11 is the median value.

About half the students checked Facebook between 11 and 18 times that day.

Approximately 4 to 5 students checked Facebook between 2 and 7 times that day.

Approximately 4 to 5 students checked Facebook between 7 and 11 times that day.

Approximately 4 to 5 students checked Facebook between 11 and 18 times that day.

Approximately 4 to 5 students checked Facebook between 18 and 62 times that day.

61. An outlier causes a box-and-whisker plot to have a long whisker.

62. The median always represents: 4. The 50th percentile

Lesson 11.10
Chapter 11 Test

1.

Stem-and-Leaf Plots: is an organization of numerical data into categories based on place value. For a stem-and-leaf plot, each number will be divided into two parts using place value. The stem is the left-hand column and will contain the digits in the largest place. The right-hand column will be the leaf and it will contain the digits in the smallest place.

One advantage is that they allow you to quickly view the median and mode of the data.

One disadvantage is that they require sorting the data manually.

Histograms: is a bar chart that describes a frequency distribution.

The horizontal axis of the histogram is separated into equal intervals. The vertical bars represent how many items are in each interval.

One advantage of histograms is that they are easy to read and allow use to make conclusions about the data quickly.

One disadvantage of histograms is that they only show frequency distribution and may not include individual data values.

Box-and-Whisker Plots: is another type of graph used to display data. It shows how the data are dispersed around a median. A box-and-whisker plot is a graph based upon medians. It shows the minimum value, the lower median, the median, the upper median and the maximum value of a data set. It is also known as a box plot.

One advantage of this type of graph is it often used when the number of data values is large or when two or more data sets are being compared.

One disadvantage is that it does not show specific values in the data. It does not show a distribution in as much detail as does a stem-and-leaf plot or a histogram.

2. $f(x) = 7 + \sqrt{x-4}$

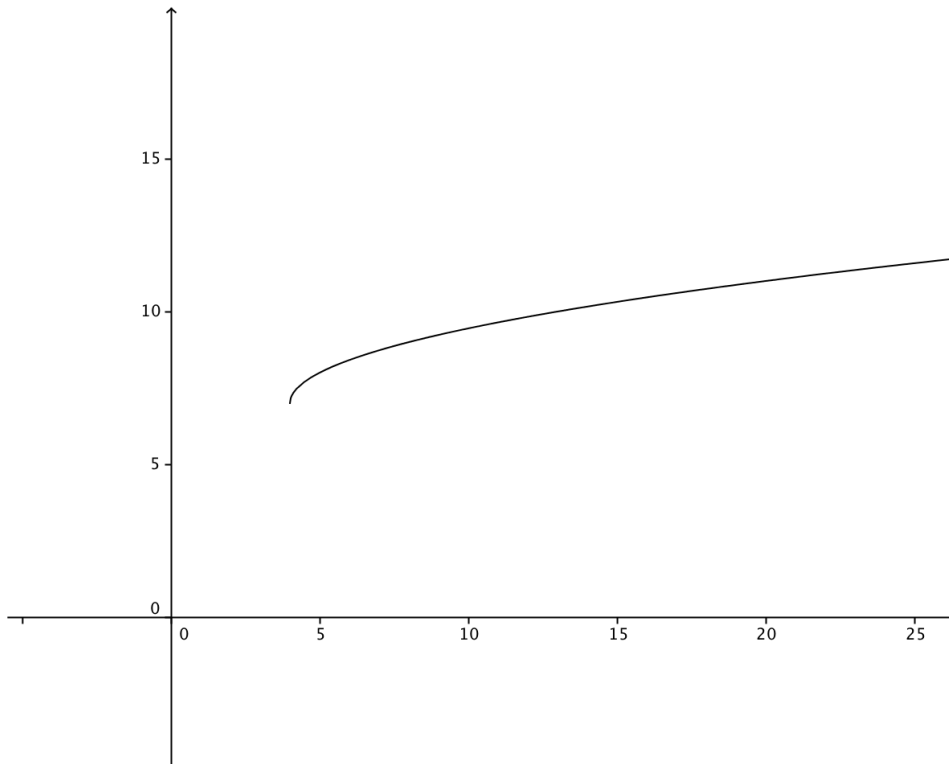

Domain: $x \geq 4$

Range: $y \geq 7$

Origin = (4,7)

3. False: The upper quartile is the MEDIAN of the upper half of the data.

4. Domain: $x \geq 0$

5.

$$-6 = 2\sqrt[3]{c+5}$$

$$-3 = \sqrt[3]{c+5}$$

$$(-3)^3 = (\sqrt[3]{c+5})^3$$

$$-27 = c + 5$$

$$c = -32$$

Check

$$-6 = 2\sqrt[3]{c+5}$$

$$-6 = 2\sqrt[3]{-32+5}$$

$$-6 = 2\sqrt[3]{-27}$$

$$-6 = 2(-3)$$

$$-6 = -6$$

6.

$$\frac{4}{\sqrt{48}} = \frac{4}{\sqrt{48}} * \frac{4}{\sqrt{48}} = \frac{4\sqrt{48}}{48} = \frac{\sqrt{48}}{12} = \frac{\sqrt{16} * \sqrt{3}}{12} = \frac{\pm 4\sqrt{3}}{12} = \frac{\sqrt{3}}{3}$$

7.

$$\sqrt[3]{3} \times \sqrt[3]{81} = \sqrt[3]{243} = \sqrt[3]{27} * \sqrt[3]{9} = 3\sqrt[3]{9}$$

8.

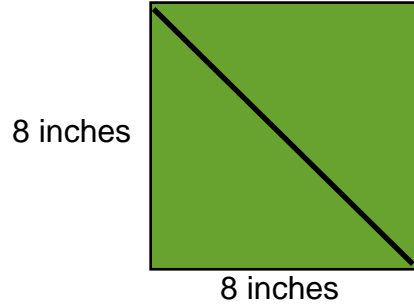

The diagonal of a square baking dish creates the hypotenuse of a right triangle. Let's use Pythagorean Theorem.

$$a^2 + b^2 = c^2$$

$$8^2 + 8^2 = c^2$$

$$64 + 64 = c^2$$

$$128 = c^2$$

$$c = \sqrt{128}$$

$$c = \sqrt{64} * \sqrt{2}$$

$$c = 8\sqrt{2}$$

The length of the diagonal is $8\sqrt{2}$

Now let's find the area of the triangle created by this diagonal.

$$A = \frac{1}{2}bh$$

$$A = \frac{1}{2}(8)(8)$$

$$A = 32$$

The area of half the pan is 32 square inches.

9.

1.

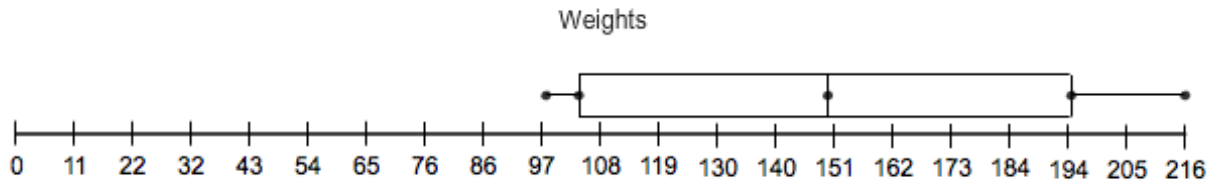

Weights	
Stem	Leaf
9	8, 8, 9
10	0, 0, 0, 4, 6, 8
11	6
12	-----
13	5
14	2
15	0
16	0
17	-----
18	0
19	5, 5, 5, 5
20	6, 6
21	0, 2, 6

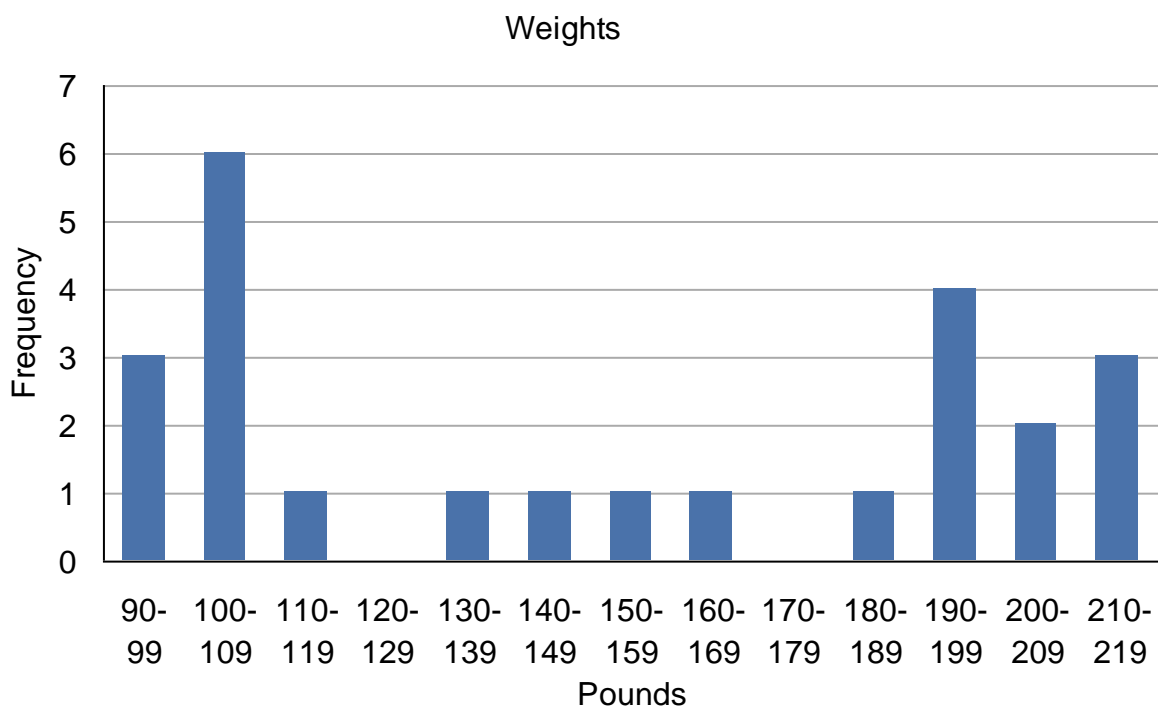

2. Which method is better depends on what you are using the data for, but in general the stem and leaf plot gives the most detail without any difficulty reading it.

3. No: the lowest data is represented more than once and so is the highest data. The range is large, but accurate.

4. There is great variance in the weights of HS students with most of the students falling in the lower end or the higher end with less in the middle.

10.

$$d = \sqrt{(y_2 - y_1)^2 + (x_2 - x_1)^2}$$

$$d = \sqrt{(-2 - (-9))^2 + (-6 - 5)^2}$$

$$d = \sqrt{7^2 + (-11)^2}$$

$$d = \sqrt{49 + 121}$$

$$d = \sqrt{170}$$

$$d \approx 13.0384$$

11.

1.

$$d = \sqrt{(y_2 - y_1)^2 + (x_2 - x_1)^2}$$

$$d = \sqrt{(80.224 - 70.269)^2 + (25.79 - 43.665)^2}$$

$$d = \sqrt{9.955^2 + (-17.875)^2}$$

$$d = \sqrt{99.102025 + 319.515625}$$

$$d = \sqrt{418.61765}$$

$$d \approx 20.4601$$

2.

$$(x_m, y_m) = \left(\frac{x_1 + x_2}{2}, \frac{y_1 + y_2}{2} \right)$$

$$(x_m, y_m) = \left(\frac{43.665 + 25.79}{2}, \frac{70.269 + 80.224}{2} \right)$$

$$(x_m, y_m) = \left(\frac{69.455}{2}, \frac{150.493}{2} \right)$$

$$(x_m, y_m) = (34.7275, 75.2465)$$

12.

$$s^2 = 3.5B^3$$

$$26^2 = 3.5B^3$$

$$676 = 3.5B^3$$

$$193.1429 \approx B^3$$

$$B \approx \sqrt[3]{193.1429}$$

$$B \approx 5.7804$$

13.

$(2,2) \& (5,y)$

$$d = 10$$

$$d = \sqrt{(y_2 - y_1)^2 + (x_2 - x_1)^2}$$

$$10 = \sqrt{(2 - y)^2 + (2 - 5)^2}$$

$$10 = \sqrt{(2 - y)^2 + (-3)^2}$$

$$10 = \sqrt{y^2 - 4y + 4 + 9}$$

$$10 = \sqrt{y^2 - 4y + 13}$$

$$10^2 = \left(\sqrt{y^2 - 4y + 13}\right)^2$$

$$100 = y^2 - 4y + 13$$

$$87 = y^2 - 4y$$

$$87 + 4 = y^2 - 4y + 4$$

$$91 = (y - 2)^2$$

$$\sqrt{91} = \sqrt{(y - 2)^2}$$

$$\sqrt{91} = y - 2$$

$$y = 2 + \sqrt{91}$$

$$y \approx 2 \pm 9.5394$$

$$y \approx 2 + 9.5394$$

$$y \approx 11.5394$$

$$y \approx 2 - 9.5394$$

$$y \approx -7.5394$$

The two possibilities are $(5, 11.5394)$ and $(5, -7.5394)$

14.

1.

Mean = \bar{x} = *average*

$$\bar{x} = \frac{9036 + 505 + 1870 + 826 + 628 + 187 + 452 + 1106 + 390 + 719}{10}$$

$$\bar{x} = \frac{15719}{10}$$

$$\bar{x} = 1571.9$$

Median = *middle#*

Med = 187, 390, 452, 505, (628, 719), 826, 1106, 1870, 9036

$$\text{Med} = \frac{628 + 719}{2}$$

$$\text{Med} = \frac{1347}{2}$$

$$\text{Med} = 673.5$$

Mode = # *appears* > *times*

Mode = 187, 390, 452, 505, 628, 719, 826, 1106, 1870, 9036

Mode = NONE

Range = *highest* – *lowest*

$$R = 9036 - 187$$

$$R = 8849$$

σ = *deviation*

$$\sigma = \sqrt{\frac{(x_1 - \bar{x})^2 + (x_2 - \bar{x})^2 + \dots + (x_n - \bar{x})^2}{n}}$$

$$\sigma = \sqrt{\frac{(187 - 1571.9)^2 + (390 - 1571.9)^2 + (452 - 1571.9)^2 + (505 - 1571.9)^2 + (628 - 1571.9)^2 + (719 - 1571.9)^2 + (826 - 1571.9)^2 + (1106 - 1571.9)^2 + (1870 - 1571.9)^2 + (9036 - 1571.9)^2}{10}}$$

$$\sigma = \sqrt{\frac{63900754.9}{10}}$$

$$\sigma = \sqrt{6390075.49}$$

$$\sigma \approx 2527.8599$$

2. Yes there are outliers. This raises the mean and the range.

Algebra Solution Key
Chapter 12
Rational Equations and Functions; Statistics

Lesson 12.1
Inverse Variation Models

1. Inverse variation is when the two variables change differently (when one goes up the other goes down, etc.)

2. In direct variation, the two variables change in the same way, while in inverse variation they change in opposite ways. Direct variation relationships have graphs that always go through the origin, while inverse variation relationships never cross the axes. The graph of a direct variation is a line, while the graph of an inverse variation creates a hyperbola. Additionally in an inverse variation x can never be zero and k must be a counting number, while these restrictions do not hold true for direct variation.

3. varies directly

4. neither

5. varies inversely

6. varies directly

7. varies directly

8. neither

9. varies inversely

10. varies inversely

11. $y = \frac{3}{x}$

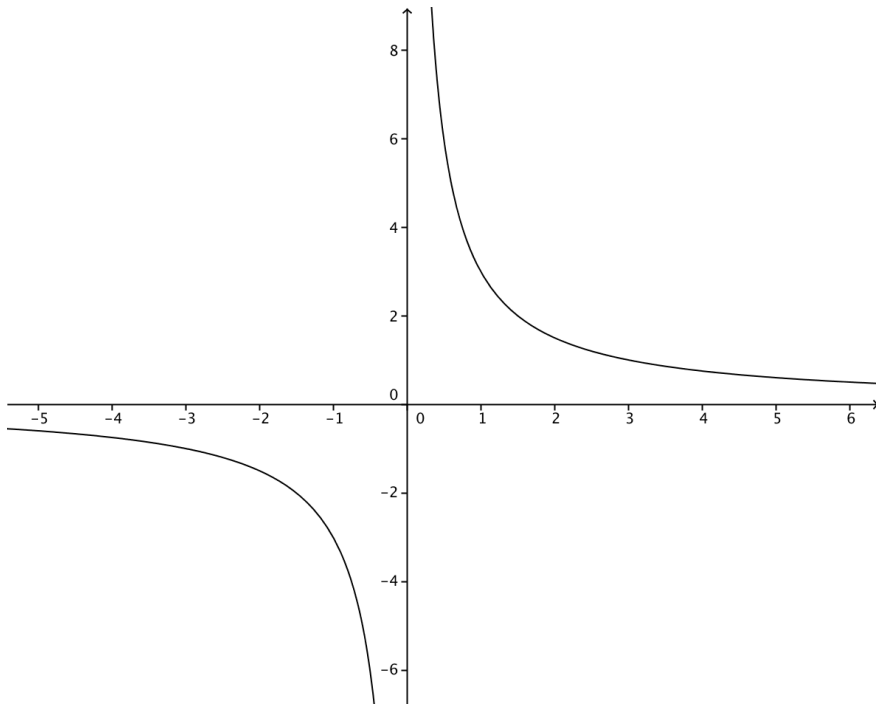

Domain : $x \neq 0$, Range: $y \neq 0$

12. $y = \frac{1}{x^2}$

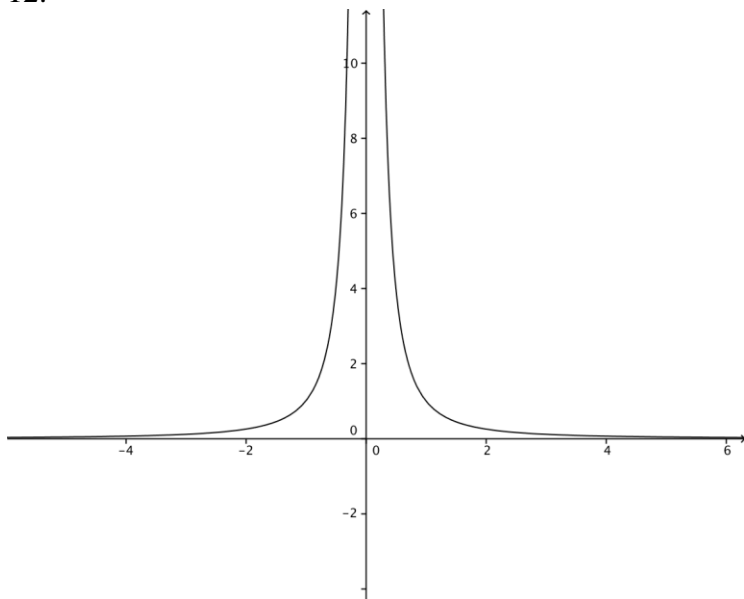

Domain : $x \neq 0$, Range: $y \neq 0$

13. $f(x) = -\frac{4}{x}$

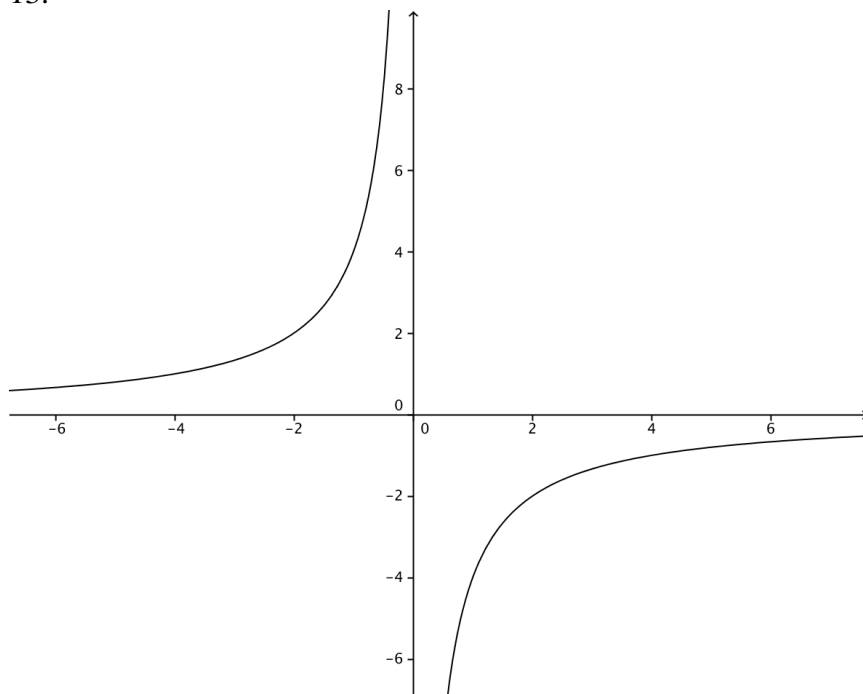

Domain : $x \neq 0$, Range: $y \neq 0$

14. $y = \frac{10}{x}$

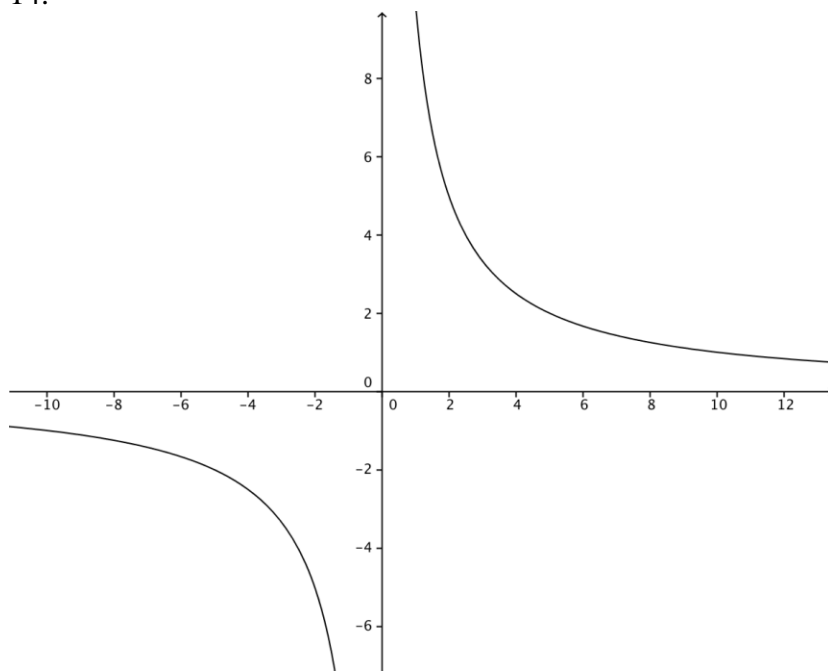

Domain : $x \neq 0$, Range: $y \neq 0$

15. $h(x) = -\frac{1}{x}$

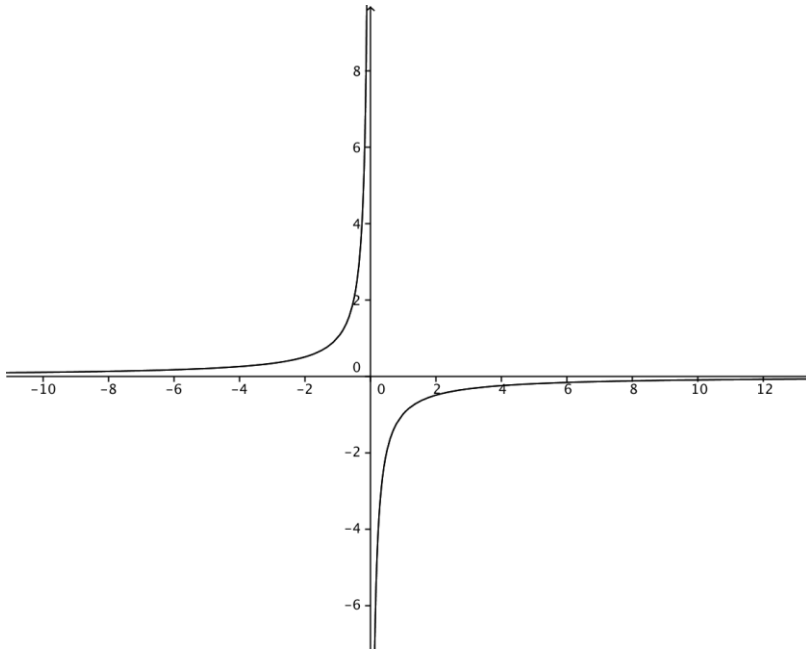

Domain : $x \neq 0$, Range: $y \neq 0$

16. $y = \frac{1}{4x}$

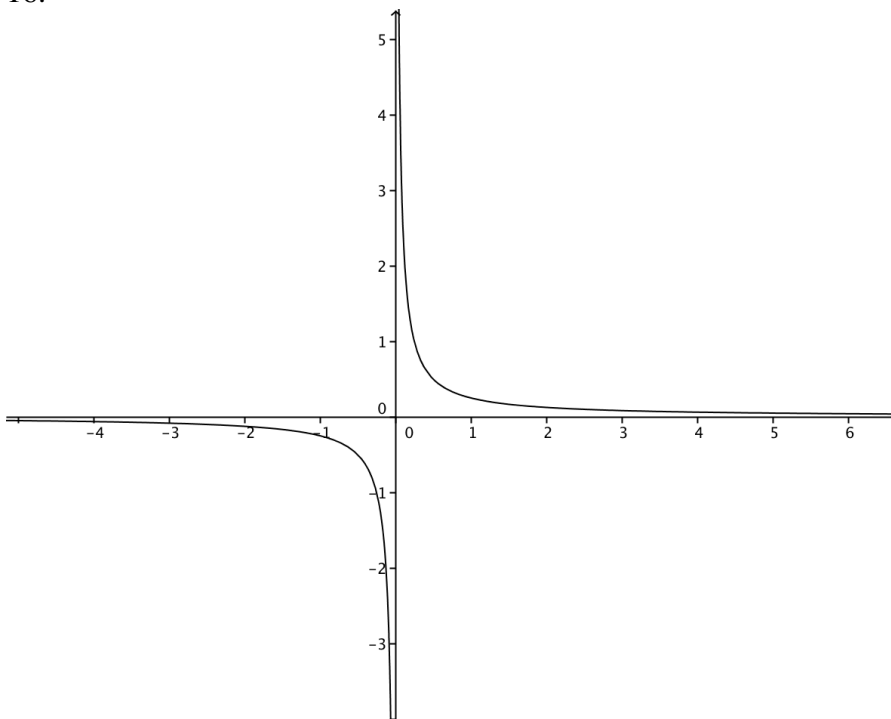

Domain : $x \neq 0$, Range: $y \neq 0$

17. $g(x) = -\frac{2}{x^2}$

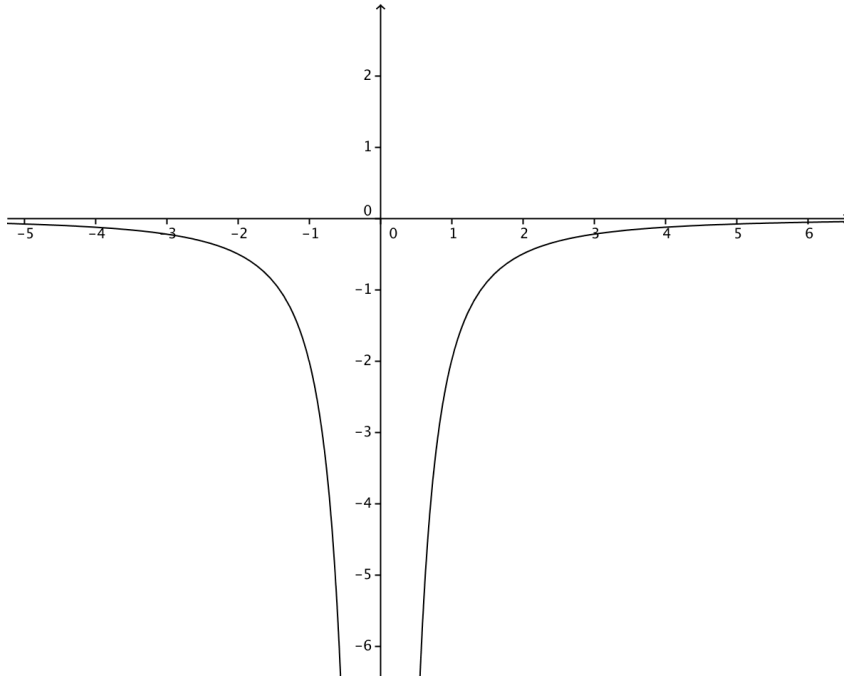

Domain : $x \neq 0$, Range: $y \neq 0$

18. $y = \frac{4}{x^2}$

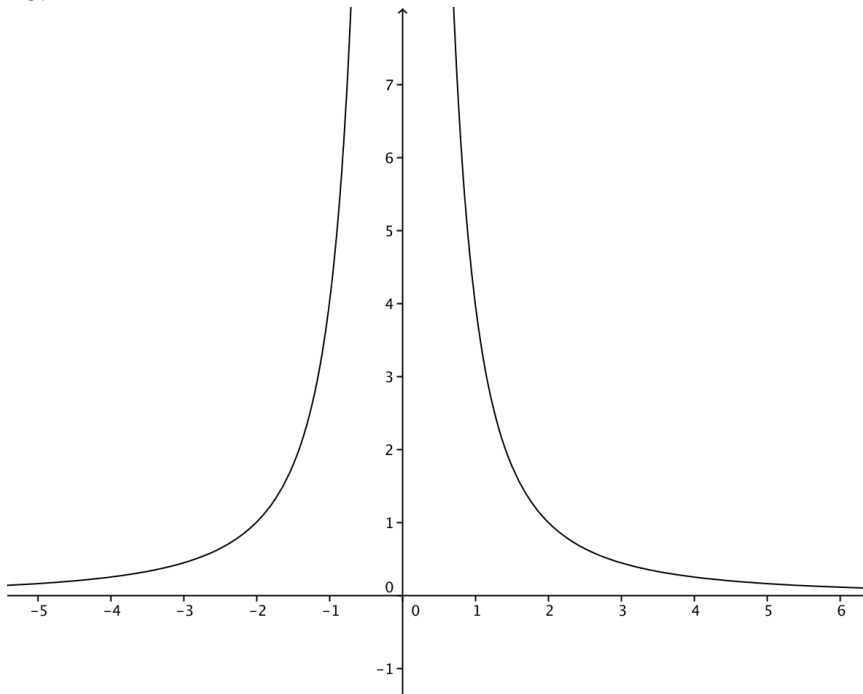

Domain : $x \neq 0$, Range: $y \neq 0$

19. $y = \frac{5}{6x}$

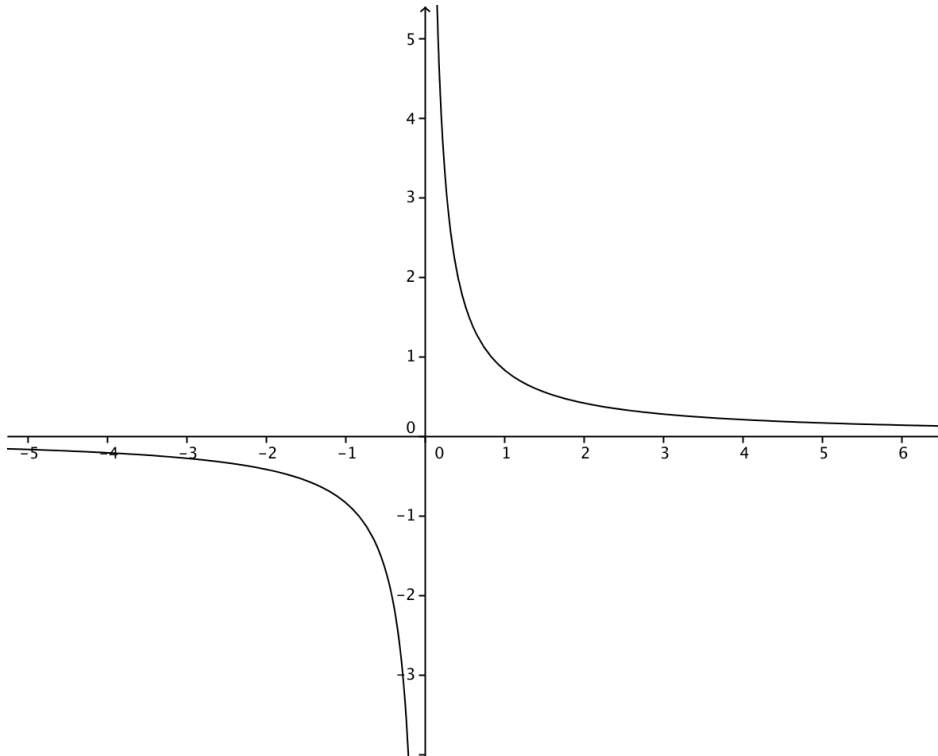

Domain : $x \neq 0$, Range: $y \neq 0$

20.

$$y = \frac{k}{x}$$

$$24 = \frac{k}{3}$$

$$k = 72$$

$$y = \frac{72}{-1.5} = -48$$

21.

$$d = \frac{k}{t^3}$$

$$-23.5 = \frac{k}{3^3}$$

$$-23.5 = \frac{k}{27}$$

$$k \approx -0.8704$$

$$d \approx \frac{-0.8704}{(0.25)^3} \approx \frac{-0.8704}{0.0156} \approx -55.7949$$

22.

$$z = \frac{k}{w}$$

$$81 = \frac{k}{9}$$

$$k = 729$$

$$24 = \frac{729}{w}$$

$$24w = 729$$

$$w = 30.375$$

23.

$$y = \frac{k}{x}$$

$$2 = \frac{k}{8}$$

$$k = 16$$

$$y = \frac{16}{12} = \frac{4}{3}$$

24.

$$a = \frac{k}{\sqrt{b}}$$

$$32 = \frac{k}{\sqrt{9}}$$

$$32 = \frac{k}{\pm 3}$$

$$k = \pm 96$$

$$6 = \frac{96}{\sqrt{b}}$$

$$6\sqrt{b} = 96$$

$$\sqrt{b} = 16$$

$$b = 16^2$$

$$b = 256$$

25.

$$w = \frac{k}{u^2}$$

$$4 = \frac{k}{2^2}$$

$$4 = \frac{k}{4}$$

$$k = 16$$

$$w = \frac{16}{8^2}$$

$$w = \frac{16}{64} = \frac{1}{4} = 0.25$$

26. d = distance from fulcrum, w = weight of object

$$d = \frac{k}{w}$$

$$6 = \frac{k}{40}$$

$$k = 240$$

$$d = \frac{240}{65} \approx 3.6923$$

Josh would have to sit approximately 3.6923 feet from the fulcrum to balance the seesaw.

27. l = intensity of light, d = distance between source and object

$$l = \frac{k}{d^2}$$

$$35 = \frac{k}{10^2}$$

$$35 = \frac{k}{100}$$

$$k = 3500$$

$$l = \frac{3500}{25^2} = \frac{3500}{625} = 5.6$$

The intensity would register 5.6 lux.

28. c = current in wire, r = resistance of wire

$$c = \frac{k}{r}$$

$$2.5 = \frac{k}{20}$$

$$k = 50$$

$$5 = \frac{50}{r}$$

$$5r = 50$$

$$r = 10$$

The resistance would be 10 ohms.

29. n = number of tiles, s = length of the side of a tile

$$n = \frac{k}{s^2}$$

$$112 = \frac{k}{6^2}$$

$$112 = \frac{k}{36}$$

$$k = 4032$$

$$n = \frac{4032}{8^2} = \frac{4032}{64} = 63$$

It would take 63 eight-inch tiles to cover the floor.

30.

$$16 \geq -3x + 5$$

$$11 \geq -3x$$

$$-\frac{11}{3} \geq x$$

$$x \leq -3.6667$$



31. $x = \frac{7}{14}$

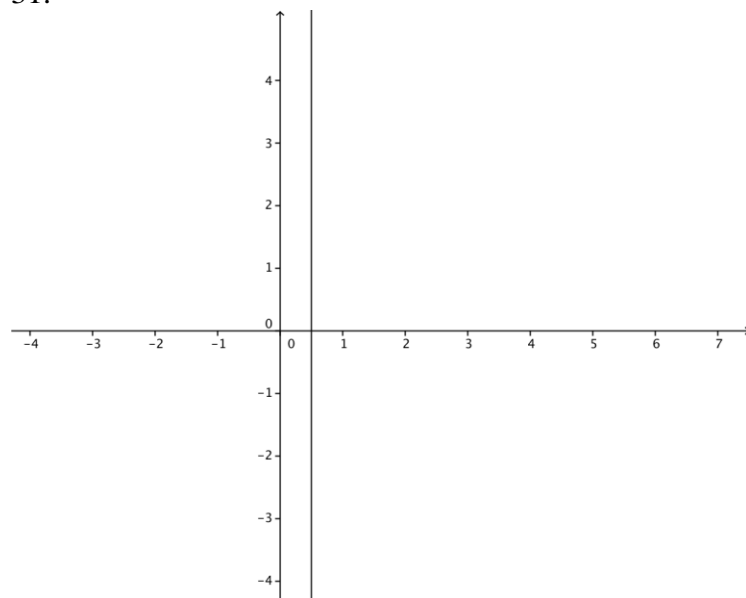

32. $\sqrt[3]{320} = \sqrt[3]{64} * \sqrt[3]{5} = 4\sqrt[3]{5}$

33. The Commutative Property of Multiplication states that $a(b) = b(a)$.

34.

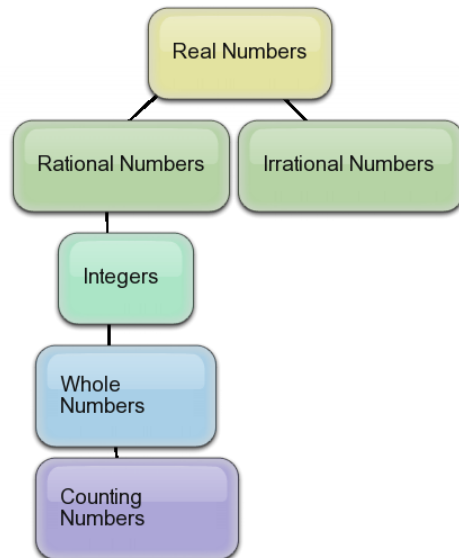

Answers for examples will vary, any that fit the definitions are correct.

Real Numbers: all numbers of any size, that are not imaginary

Rational Numbers: any number that can be made by dividing one integer into another

Irrational Numbers: any number that cannot be written as a simple fraction, the decimals go on forever without repeating

Integers: are all numbers with no fractional or decimal piece, they include all positive and negative numbers, as well as zero

Whole Numbers: are numbers with no fractional or decimal part and zero, but they do not include negative numbers

Counting Numbers: All numbers greater than (not including) zero, that have no fractional or decimal part.

35.

$17.5\% \text{ of } 96$

$17.5\% * 96$

$.175 * 96$

16.8

Lesson 12.2

Graphs of Rational Functions

$$f(x) = \frac{g(x)}{h(x)}, h \neq 0$$

1. A rational function is a ratio of two polynomials (one divided by the other).
2. An asymptote is a straight line to which, as the distance from the origin gets larger, a curve get closer and closer but never intersects. The relationship between asymptotes and rational functions is that where an asymptote exists, the function is undefined.
3. This lesson describes vertical and horizontal asymptotes. The general equation for vertical asymptotes is

$$f(x) = \frac{g(x)}{h(x)}, h(x) = 0$$

(A vertical asymptote occurs when there is a zero in the denominator) The general equation for horizontal asymptotes is $y=c$, where c is the vertical shift.

4.

$$y = \frac{4}{x+2}$$

$$x+2 = 0$$

$$x = -2$$

$$y = c$$

$$y = 0$$

The vertical asymptote is $x=-2$.

The horizontal asymptote is $y=0$.

5.

$$f(x) = \frac{5}{2x-6} + 3$$

$$2x - 6 = 0$$

$$2x = 6$$

$$x = 3$$

$$y = c$$

$$y = 3$$

The vertical asymptote is $x=3$.

The horizontal asymptote is $y=3$.

6.

$$y = \frac{10}{x}$$

$$x = 0$$

$$y = 0$$

The vertical asymptote is $x=0$.

The horizontal asymptote is $y=0$.

7.

$$g(x) = \frac{4}{4x^2 + 1} - 2$$

$$4x^2 + 1 = 0$$

$$4x^2 = -1$$

$$x^2 = -\frac{1}{4}$$

$$x \neq \sqrt{-\frac{1}{4}}$$

$$y = c$$

$$y = -2$$

There is no vertical asymptote.

The horizontal asymptote is $y=-2$.

8.

$$h(x) = \frac{2}{x^2 - 9}$$

$$x^2 - 9 = 0$$

$$x^2 = 9$$

$$x = \pm 3$$

$$y = c$$

$$y = 0$$

The vertical asymptotes are $x=3$ and $x=-3$.

The horizontal asymptote is $y=0$.

9.

$$y = \frac{1}{x^2 + 4x + 3} + \frac{1}{2}$$

$$x^2 + 4x + 3 = 0$$

$$(x + 3)(x + 1) = 0$$

$$x + 3 = 0$$

$$x = -3$$

$$x + 1 = 0$$

$$x = -1$$

$$y = c$$

$$y = \frac{1}{2}$$

The vertical asymptotes are $x = -3$ and $x = -1$.

The horizontal asymptote is $y = 1/2$.

10.

$$y = \frac{3}{x^2 - 4} - 8$$

$$x^2 - 4 = 0$$

$$x^2 = 4$$

$$x = \pm 2$$

$$y = c$$

$$y = -8$$

The vertical asymptotes are $x = 2$ and $x = -2$.

The horizontal asymptote is $y = -8$.

11.

$$f(x) = \frac{-3}{x^2 - 2x - 8}$$

$$x^2 - 2x - 8 = 0$$

$$(x - 4)(x + 2) = 0$$

$$x - 4 = 0$$

$$x = 4$$

$$x + 2 = 0$$

$$x = -2$$

$$y = c$$

$$y = 0$$

The vertical asymptotes are $x=4$ and $x=-2$.

The horizontal asymptote is $y=0$.

12. $y = -\frac{6}{x}$

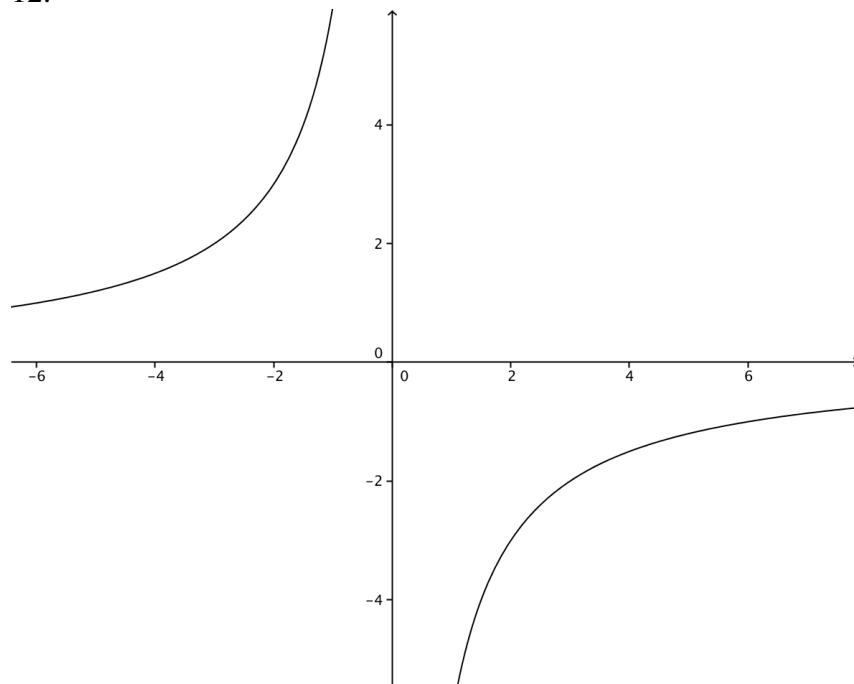

The axes are the horizontal and vertical asymptotes.

13. $y = \frac{x}{2-x^2} - 3$

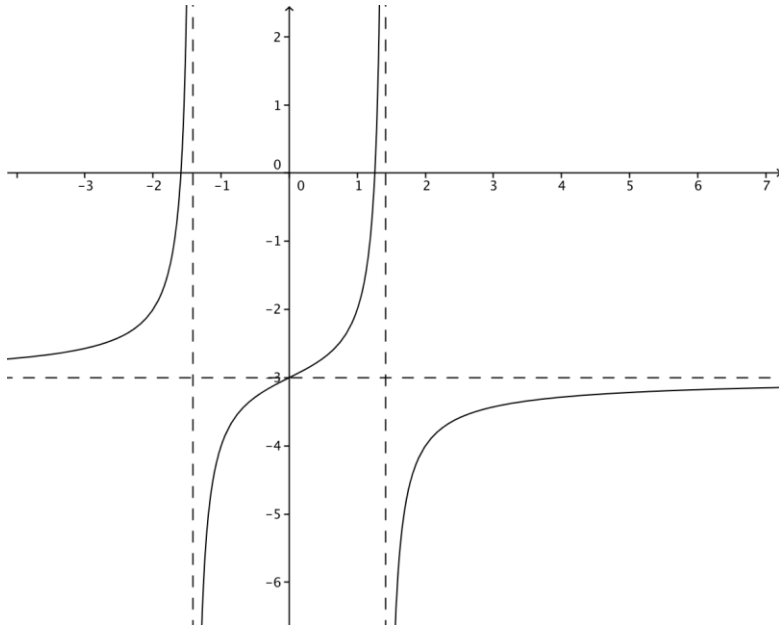

14. $f(x) = \frac{3}{x^2}$

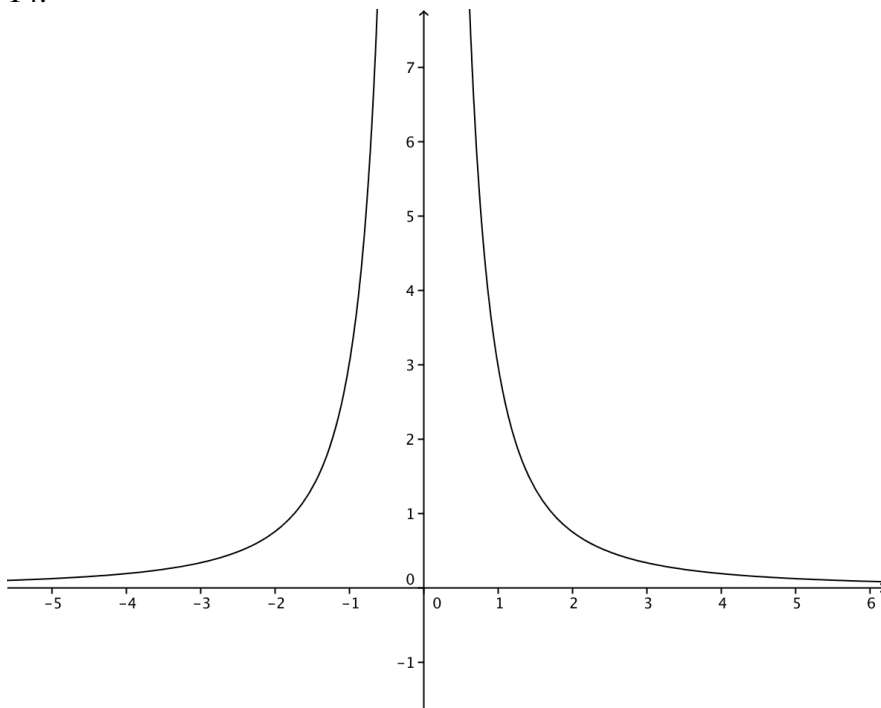

The axes are the horizontal and vertical asymptotes.

15. $g(x) = \frac{1}{x-1} + 5$

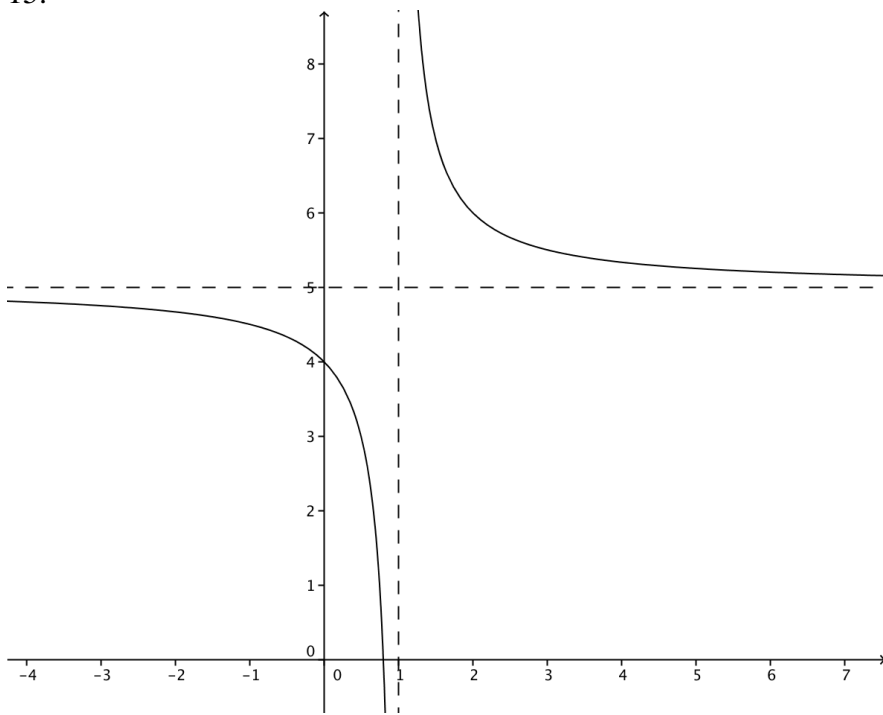

16. $y = \frac{2}{x+2} - 6$

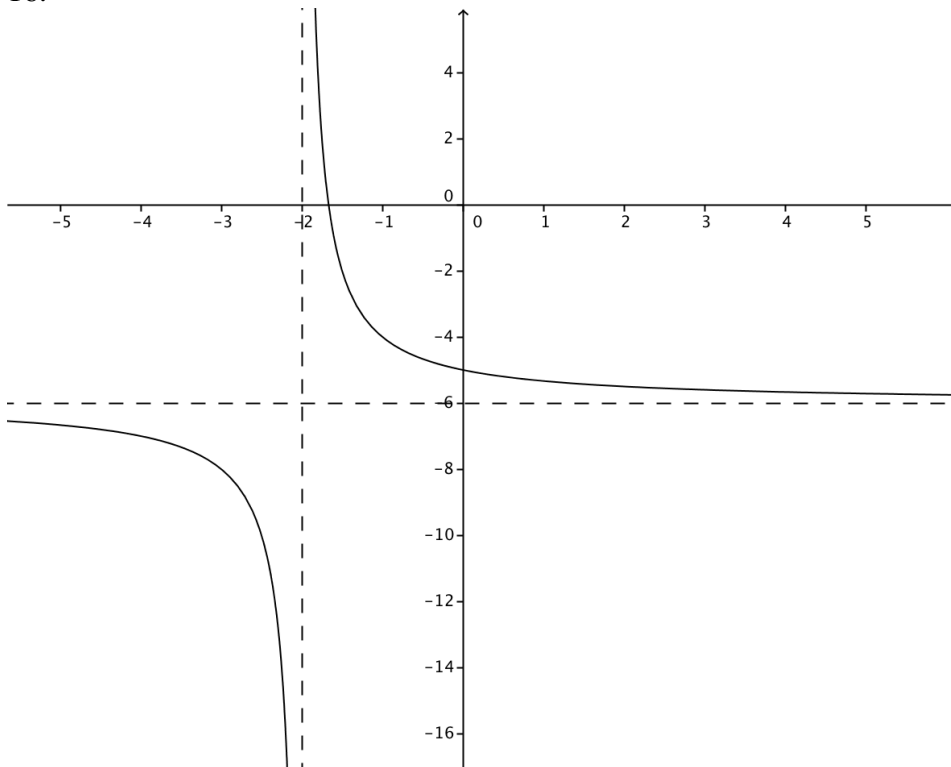

17. $f(x) = \frac{-1}{x^2 + 2}$

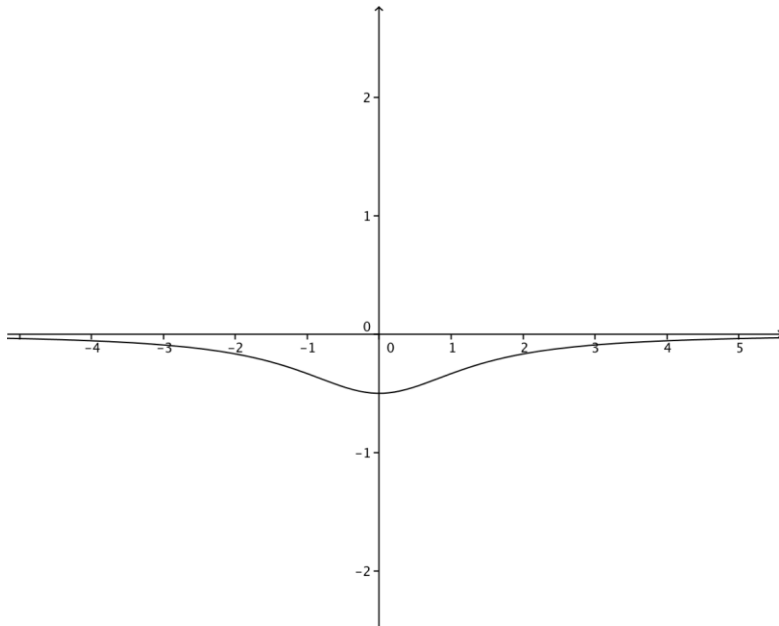

This function has no vertical asymptotes. The horizontal asymptote is the x-axis.

18. $h(x) = \frac{4}{x^2 + 9}$

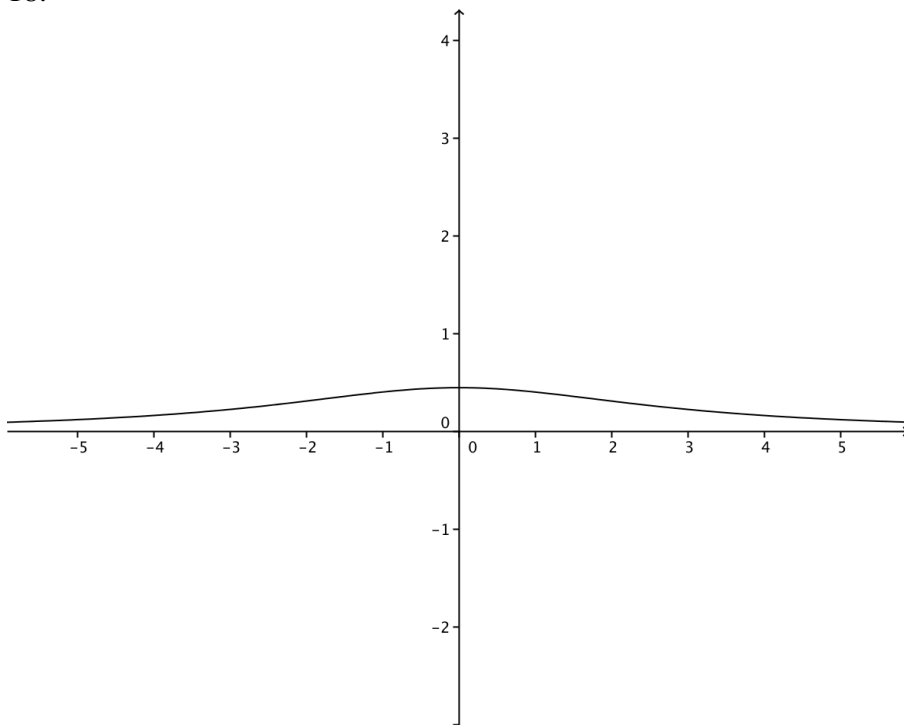

This function has no vertical asymptotes. The horizontal asymptote is the x-axis.

19. $y = \frac{-2}{x^2 + 1}$

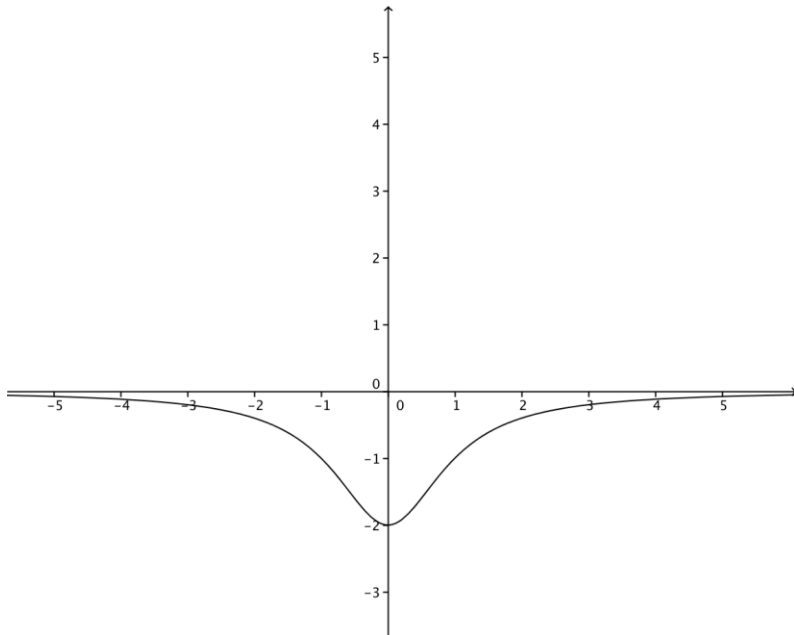

This function has no vertical asymptotes. The horizontal asymptote is the x-axis.

20. $j(x) = \frac{1}{x^2 - 1} + 1$

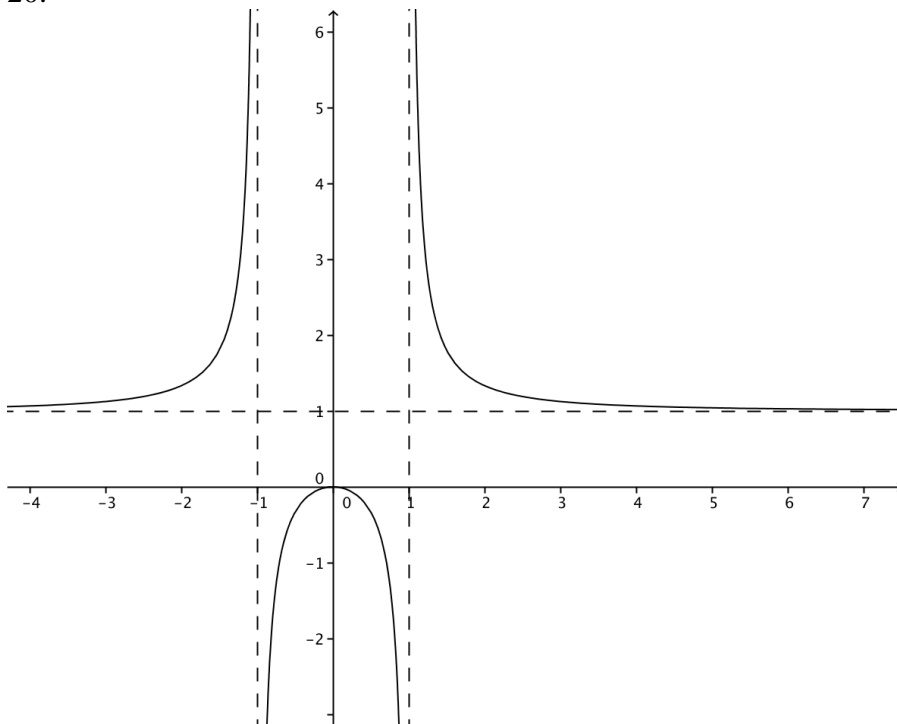

21. $y = \frac{2}{x^2 - 9}$

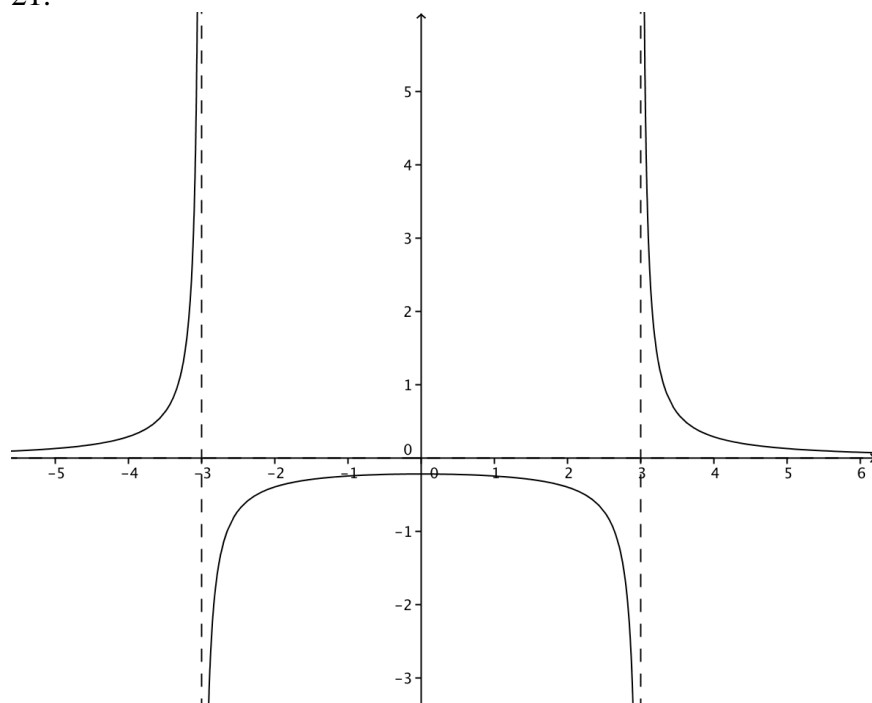

The horizontal asymptote is the x -axis.

22. $f(x) = \frac{8}{x^2 - 16}$

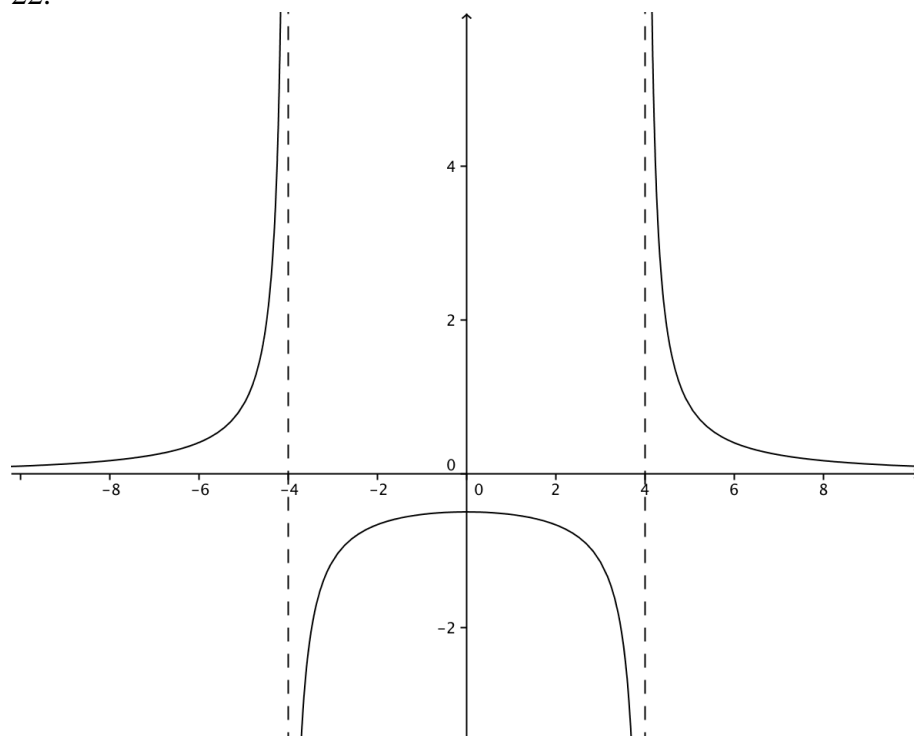

The horizontal asymptote is the x -axis.

23. $g(x) = \frac{3}{x^2 - 4x + 4}$

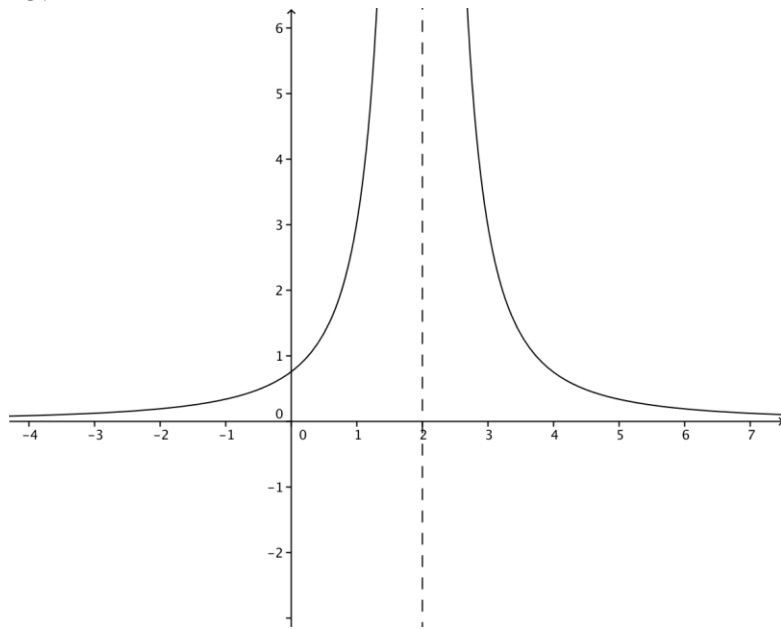

The horizontal asymptote is the x-axis.

24. $h(x) = \frac{1}{x^2 - x - 6}$

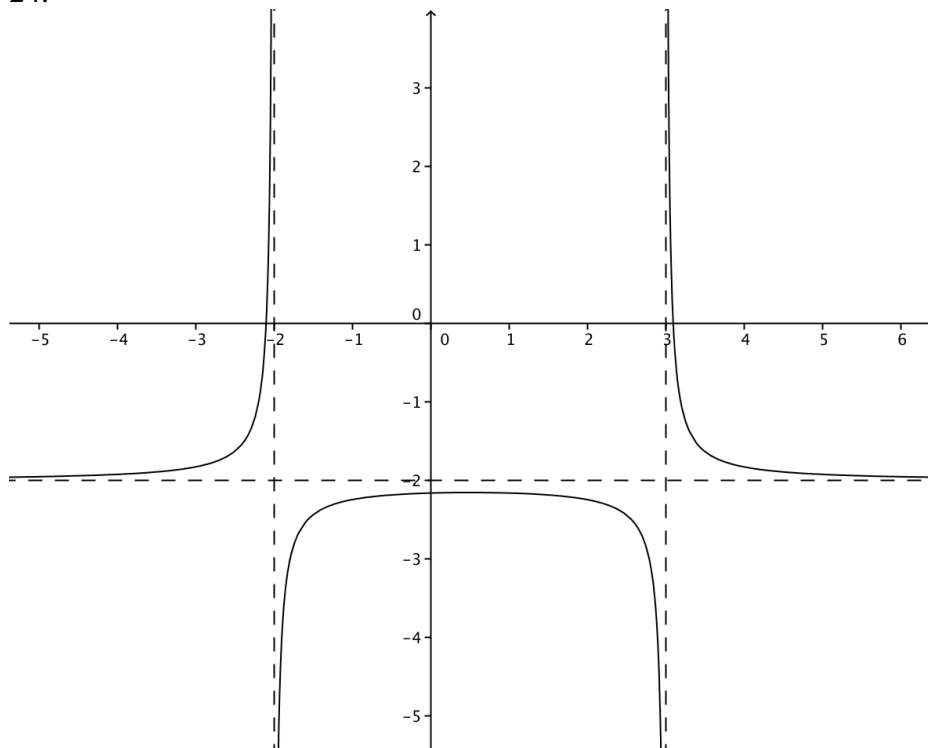

25.

$$I = \frac{V}{R}$$

$$1.5 = \frac{x}{12}$$

$$x = 18$$

The missing quantity is 18V.

26.

$$I = \frac{V}{R}$$

$$1.2 = \frac{27}{10+x}$$

$$1.2(10+x) = 27$$

$$12 + 1.2x = 27$$

$$1.2x = 15$$

$$x = 12.5$$

27.

$$I = \frac{V}{R}$$

$$x = \frac{15}{\frac{1}{10} + \frac{1}{15}}$$

$$x = \frac{15}{\frac{1}{6}} = 15 \div \frac{1}{6} = 15 * \frac{6}{1} = 15 * 6$$

$$x = 90$$

The missing quantity is 90 A.

Mixed Review

28.

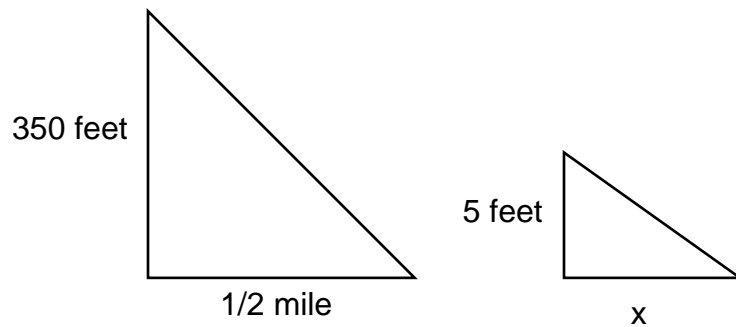

$$\frac{1}{2} \text{ mile} = 2640 \text{ feet}$$

$$\frac{350}{2640} = \frac{5}{x}$$

$$350x = 13200$$

$$x = 37.7143$$

The person's shadow is approximately 37.7143 feet.

29. The Cross Product Property states that you can solve a proportion by multiplying the means

and the extremes. $\frac{a}{b} = \frac{c}{d} \rightarrow ad = cb$

30.

(1,1) & (-4,5)

$$m = \frac{y_2 - y_1}{x_2 - x_1}$$

$$m = \frac{5 - 1}{-4 - 1} = \frac{4}{-5} = -0.8$$

31.

$$y = kx$$

$$12 = k(120)$$

$$\frac{12}{120} = k$$

$$k = .10$$

You receive \$0.10 per can.

32.

$$\frac{2}{8} = \frac{1}{4}$$

33. Any answer that includes a variable to the 6th power and 2 terms (with no negative exponents) is correct.

Lesson 12.3

Division of Polynomials

1.

$$\frac{2x+4}{2} = \frac{2x}{2} + \frac{4}{2} = x+2$$

2.

$$\frac{x-4}{x} = \frac{x}{x} - \frac{4}{x} = 1 - \frac{4}{x}$$

3.

$$\frac{5x-35}{5x} = \frac{5x}{5x} - \frac{35}{5x} = 1 - \frac{7}{x}$$

4.

$$\frac{x^2+2x-5}{x} = \frac{x^2}{x} + \frac{2x}{x} - \frac{5}{x} = x+2 - \frac{5}{x}$$

5.

$$\frac{4x^2+12x-36}{-4x} = \frac{4x^2}{-4x} + \frac{12x}{-4x} - \frac{36}{-4x} = -x-3 + \frac{9}{x}$$

6.

$$\frac{2x^2+10x+7}{2x^2} = \frac{2x^2}{2x^2} + \frac{10x}{2x^2} + \frac{7}{2x^2} = 1 + \frac{5}{x} + \frac{7}{2x^2}$$

7.

$$\frac{x^3-x}{-2x^2} = \frac{x^3}{-2x^2} - \frac{x}{-2x^2} = -\frac{x}{2} + \frac{1}{2x}$$

8.

$$\frac{5x^4-9}{3x} = \frac{5x^4}{3x} - \frac{9}{3x} = \frac{5x^3}{3} - \frac{3}{x}$$

9.

$$\frac{x^3 - 12x^2 + 3x - 4}{12x^2} = \frac{x^3}{12x^2} - \frac{12x^2}{12x^2} + \frac{3x}{12x^2} - \frac{4}{12x^2} = \frac{x}{12} - 1 + \frac{1}{4x}$$

10.

$$\frac{3 - 6x + x^3}{-9x^3} = \frac{3}{-9x^3} - \frac{6x}{-9x^3} + \frac{x^3}{-9x^3} = -\frac{1}{3x^3} + \frac{2}{3x^2} - \frac{1}{9}$$

11.

$$\frac{x^2 + 3x + 6}{x + 1}$$

$$\begin{array}{r} x+2 \\ x+1 \overline{)x^2+3x+6} \\ \underline{-x^2-x} \\ 0+2x+6 \\ \underline{0-2x-2} \\ 0+0+4 \end{array}$$

$$x + 2r4$$

12.

$$\frac{x^2 - 9x + 6}{x - 1}$$

$$\begin{array}{r} x-8 \\ x-1 \overline{)x^2-9x+6} \\ \underline{-x^2+x} \\ 0-8x+6 \\ \underline{0+8x-8} \\ 0+0-2 \end{array}$$

$$x - 8r(-2)$$

13.

$$\frac{x^2 + 5x + 4}{x + 4}$$

$$\begin{array}{r} x+4 \overline{)x^2 + 5x + 4} \\ \underline{-x^2 - 4x} \\ 0 + x + 4 \\ \underline{0 - x - 4} \\ 0 \end{array}$$

$x + 1$

14.

$$\frac{x^2 - 10x + 25}{x - 5}$$

$$\begin{array}{r} x-5 \overline{)x^2 - 10x + 25} \\ \underline{-x^2 + 5x} \\ 0 - 5x + 25 \\ \underline{0 + 5x - 25} \\ 0 \end{array}$$

$x - 5$

15.

$$\frac{x^2 - 20x + 12}{x - 3}$$

$$\begin{array}{r} x-3 \overline{)x^2 - 20x + 12} \\ \underline{-x^2 + 3x} \\ 0 - 17x + 12 \\ \underline{0 + 17x - 51} \\ 0 + 0 - 39 \end{array}$$

$x - 17r(-39)$

16.

$$\frac{3x^2 - x + 5}{x - 2}$$

$$\begin{array}{r} 3x + 5 \\ x - 2 \overline{) 3x^2 - x + 5} \\ \underline{-3x^2 + 6x} \\ 0 + 5x + 5 \\ \underline{0 - 5x + 10} \\ 0 + 0 + 15 \end{array}$$

$$3x + 5r15$$

17.

$$\frac{9x^2 + 2x - 8}{x + 4}$$

$$\begin{array}{r} 9x - 34 \\ x + 4 \overline{) 9x^2 + 2x - 8} \\ \underline{-9x^2 - 36x} \\ 0 - 34x - 8 \\ \underline{0 + 34x + 136} \\ 0 + 0 + 128 \end{array}$$

$$9x - 34r128$$

18.

$$\frac{3x^2 - 8x - 3}{3x + 1}$$

$$\begin{array}{r} \overline{) 3x^2 - 8x - 3} \\ \underline{-3x^2 - x} \\ 0 - 9x - 3 \\ \underline{0 + 9x + 3} \\ 0 \end{array}$$

$$x - 3$$

19.

$$\frac{5x^2 + 2x - 9}{x - 1}$$

$$\begin{array}{r} \overline{) 5x^2 + 2x - 9} \\ \underline{-5x^2 + 5x} \\ 0 + 7x - 9 \\ \underline{0 - 7x + 7} \\ -2 \end{array}$$

$$5x + 7r(-2)$$

20.

$$\frac{x^2 - 6x - 12}{x + 4}$$

$$\begin{array}{r} x + 4 \overline{) x^2 - 6x - 12} \\ \underline{-x^2 - 4x} \\ 0 - 10x - 12 \\ \underline{0 + 10x + 40} \\ 0 + 0 + 28 \end{array}$$

$$x - 10r(28)$$

21.

$$\frac{x^2 - 2x}{x + 3}$$

$$\begin{array}{r} x + 3 \overline{) x^2 - 2x} \\ \underline{-x^2 - 3x} \\ 0 - 5x \\ \underline{0 + 5x + 15} \\ 0 + 0 + 15 \end{array}$$

$$x - 5r(15)$$

22.

$$\frac{x^2 + 1}{x - 1}$$

$$\begin{array}{r} x+1 \\ x-1 \overline{)x^2 + 1} \\ \underline{-x^2 + x} \\ 0 + x + 1 \\ \underline{0 - x + 1} \\ 0 + 0 + 2 \end{array}$$

$$x + 1r2$$

Mixed Review

23.

$$y = \frac{k}{x}$$

$$200 = \frac{k}{16.75}$$

$$k = 3350$$

$$60 = \frac{3350}{x}$$

$$60x = 3350$$

$$x \approx 55.8333$$

The pressure is approximately 55.8333 psi.

24. No, it is not a polynomial because it has a negative exponent.

25.

$$-\frac{3}{4} * x = -1$$

$$x = \frac{4}{3}$$

26. 36 two person teams can be made by nine individuals.

27.

$$-4 = \frac{\sqrt{m-3}}{-2}$$

$$8 = \sqrt{m-3}$$

$$8^2 = (\sqrt{m-3})^2$$

$$64 = m - 3$$

$$m = 67$$

Lesson 12.4
Rational Expressions

1.

$$\frac{4}{2x-8} = \frac{4}{2(x-4)} = \frac{2}{x-4}$$

2.

$$\frac{x^2+2x}{x} = \frac{x(x+2)}{x} = x+2$$

3.

$$\frac{9x+3}{12x+4} = \frac{3(3x+1)}{4(3x+1)} = \frac{3}{4}$$

4.

$$\frac{6x^2+2x}{4x} = \frac{2x(3x+1)}{4x} = \frac{3x+1}{2}$$

5.

$$\frac{x-2}{x^2-4x+4} = \frac{x-2}{(x-2)(x-2)} = \frac{1}{x-2}$$

6.

$$\frac{x^2-9}{5x+15} = \frac{(x+3)(x-3)}{5(x+3)} = \frac{x-3}{5}$$

7.

$$\frac{x^2+6x+8}{x^2+4x} = \frac{(x+4)(x+2)}{x(x+4)} = \frac{x+2}{x}$$

8.

$$\frac{2x^2+10x}{x^2+10x+25} = \frac{2x(x+5)}{(x+5)(x+5)} = \frac{2x}{x+5}$$

9.

$$\frac{x^2 + 6x + 5}{x^2 - x - 2} = \frac{(x+1)(x+5)}{(x+1)(x-2)} = \frac{x+5}{x-2}$$

10.

$$\frac{x^2 - 16}{x^2 + 2x - 8} = \frac{(x-4)(x+4)}{(x-4)(x+2)} = \frac{x+4}{x+2}$$

11.

$$\frac{3x^2 + 3x - 18}{2x^2 + 5x - 3} = \frac{3(x^2 + x - 6)}{(2x+3)(x-1)} = \frac{3(x+6)(x-1)}{(2x+3)(x-1)} = \frac{3(x+6)}{2x+3}$$

12.

$$\frac{x^3 + x^2 - 20x}{6x^2 + 6x - 120} = \frac{x(x^2 + x - 20)}{6(x^2 + x - 20)} = \frac{x}{6}$$

13.

$$\frac{2}{x}$$

$$x = 0$$

14.

$$\frac{4}{x+2}$$

$$x + 2 = 0$$

$$x = -2$$

15.

$$\frac{2x-1}{(x-1)^2}$$

$$x-1=0$$

$$x=1$$

16.

$$\frac{3x+1}{x^2-4}$$

$$x^2-4$$

$$(x-2)(x+2)$$

$$x-2=0$$

$$x=2$$

$$x+2=0$$

$$x=-2$$

$$x=2,-2$$

17.

$$\frac{x^2}{x^2+9}$$

There is no value for x that will make the denominator zero, therefore there are no excluded values.

18.

$$\frac{2x^2 + 3x - 1}{x^2 - 3x - 28}$$

$$x^2 - 3x - 28$$
$$(x - 7)(x + 4)$$

$$x - 7 = 0$$

$$x = 7$$

$$x + 4 = 0$$

$$x = -4$$

$$x = 7, -4$$

19.

$$\frac{5x^3 - 4}{x^2 + 3x}$$

$$x(x + 3)$$

$$x = 0$$

$$x + 3 = 0$$

$$x = -3$$

$$x = 0, -3$$

20.

$$\frac{9}{x^3 + 11x^2 + 30x}$$

$$x^3 + 11x^2 + 30x$$

$$x(x^2 + 11x + 30)$$

$$x(x+5)(x+6)$$

$$x = 0$$

$$x + 5 = 0$$

$$x = -5$$

$$x + 6 = 0$$

$$x = -6$$

$$x = 0, -5, -6$$

21.

$$\frac{4x-1}{x^2 + 3x - 5}$$

$$x^2 + 3x - 5 = 0$$

$$x^2 + 3x = 5$$

$$x^2 + 3x + 2.25 = 5 + 2.25$$

$$(x+1.5)^2 = 7.25$$

$$\sqrt{(x+1.5)^2} = \sqrt{7.25}$$

$$x+1.5 = \sqrt{7.25}$$

$$x+1.5 \approx \pm 2.6926$$

$$x+1.5 \approx 2.6926$$

$$x \approx 1.1926$$

$$x+1.5 \approx -2.6926$$

$$x \approx -4.6926$$

$$x \approx 1.1926, -4.6926$$

22.

$$\frac{5x+11}{3x^2-2x-4}$$

$$3x^2 - 2x - 4 = 0$$

$$y = \frac{-b \pm \sqrt{b^2 - 4ac}}{2a}$$

$$y = \frac{-(-2) \pm \sqrt{(-2)^2 - 4(3)(-4)}}{2(3)}$$

$$y = \frac{2 \pm \sqrt{4 + 48}}{6}$$

$$y = \frac{2 \pm \sqrt{52}}{6}$$

$$y = \frac{2 + \sqrt{52}}{6} \approx \frac{2 + 7.2111}{6} \approx \frac{9.2111}{6} \approx 1.5352$$

$$y = \frac{2 - \sqrt{52}}{6} \approx \frac{2 - 7.2111}{6} \approx \frac{-5.2111}{6} \approx -0.8685$$

$$x = 1.5352, -0.8685$$

23.

$$\frac{x^2 - 1}{2x^3 + x + 3}$$

$$2x^3 + x + 3$$
$$(2x^2 - 2x + 3)(x + 1)$$

$$x + 1 = 0$$

$$x = -1$$

$$2x^2 - 2x + 3 = 0$$

$$y = \frac{-b \pm \sqrt{b^2 - 4ac}}{2a}$$

$$y = \frac{-(-2) \pm \sqrt{(-2)^2 - 4(2)(3)}}{2(2)}$$

$$y = \frac{2 \pm \sqrt{4 - 24}}{4}$$

$$y = \frac{2 \pm \sqrt{-20}}{4}$$

Undefined

Excluded value: $x = -1$

24.

$$\frac{12}{x^2 + 6x + 1}$$

$$x^2 + 6x + 1 = 0$$

$$x^2 + 6x = -1$$

$$x^2 + 6x + 9 = -1 + 9$$

$$(x + 3)^2 = 8$$

$$\sqrt{(x + 3)^2} = \sqrt{8}$$

$$x + 3 = \sqrt{8}$$

$$x + 3 \approx \pm 2.8284$$

$$x + 3 \approx 2.8284$$

$$x \approx -0.1716$$

$$x + 3 \approx -2.8284$$

$$x \approx -5.8284$$

$$x \approx -0.1716, -5.8284$$

25.

$$\frac{1}{R_c} = \frac{1}{R_1} + \frac{1}{R_2}$$

$$\frac{1}{10} = \frac{1}{25} + \frac{1}{R_2}$$

$$\frac{1}{R_2} = \frac{3}{50}$$

$$50 = 3R_2$$

$$R_2 \approx 16.6667\Omega$$

26.

$$F = \frac{G(m_1 m_2)}{(d^2)} \rightarrow y = \frac{k}{x}$$

$$20 = \frac{G(m_1 m_2)}{(d^2)} \rightarrow 20 = \frac{k}{x} \rightarrow k = 20x$$

$$y = \frac{G(m_1 m_2)}{2(d^2)} \rightarrow y = \frac{k}{2x} \rightarrow y = \frac{20x}{2x} \rightarrow y = 10$$

When the distance is doubled, the force of attraction is cut in half = 10 Newtons.

27.

$$F = \frac{G(m_1 m_2)}{(d^2)} \rightarrow y = \frac{k}{x}$$

$$36 = \frac{G(m_1 m_2)}{(d^2)} \rightarrow 36 = \frac{k}{x} \rightarrow k = 36x$$

$$y = \frac{G(2m_1 2m_2)}{2(d^2)} \rightarrow y = \frac{2k}{2x} \rightarrow y = \frac{2(36x)}{2x} \rightarrow y = \frac{72x}{2x} = 36$$

If both the distance and the mass are doubled, the force of attraction stays the same.

28.

$$SA = 4\pi r^2$$

$$V = \frac{4}{3}\pi r^3$$

$$\frac{SA}{V} = \frac{4\pi r^2}{\frac{4}{3}\pi r^3} = \frac{3}{r}$$

29.

$$\text{side} = x$$

$$A = lwh$$

$$A = x \cdot x \cdot x$$

$$A = x^3$$

$$\text{side} = 2x$$

$$A = lwh$$

$$A = 2x \cdot 2x \cdot 2x$$

$$A = 8x^3$$

$$\frac{x^3}{8x^3} = \frac{1}{8}$$

30.

$$V_1 = \frac{4}{3}\pi r^3$$

$$V_2 = \frac{4}{3}\pi(r-4)^3 = \frac{4}{3}\pi(r^3 - 12r^2 + 48r - 64)$$

$$\frac{\frac{4}{3}\pi r^3}{\frac{4}{3}\pi(r^3 - 12r^2 + 48r - 64)} = \frac{r^3}{r^3 - 12r^2 + 48r - 64} = \frac{1}{-12r^2 + 48r - 64}$$

Mixed Review

31. "Four times p to the sixth power plus 7 times p to the third power minus 9"

32.

$$(4b^2 + b + 7b^3) + (5b^2 - 6b^4 + b^3)$$

$$-6b^4 + (7b^3 + b^3) + (4b^2 + 5b^2) + b$$

$$-6b^4 + 8b^3 + 9b^2 + b$$

33. Zero Product Property: For any real numbers a , $(0) \times a = 0$.

34. The zero product property cannot be used in this situation because none of the elements are zero.

35. $E = 4.85h + 15$

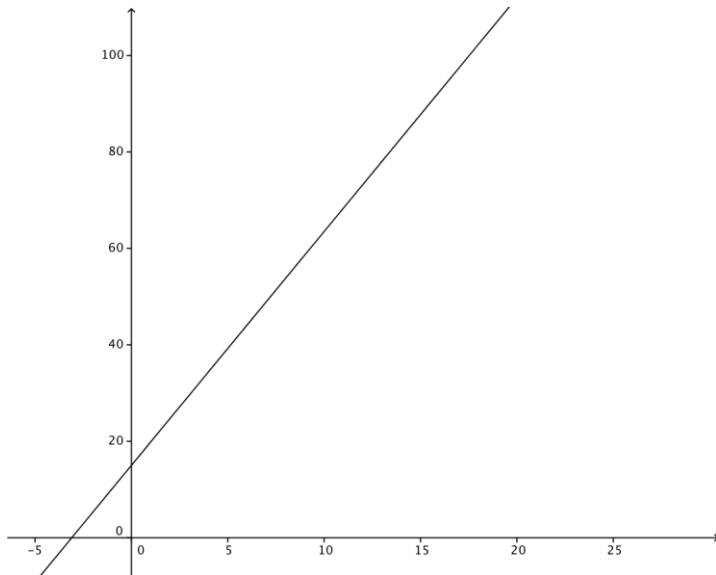

36.

$$(-4x^2 + 8x - 1)(-7x^2 + 6x + 8)$$

$$28x^4 - 24x^3 - 32x^2 - 56x^3 + 48x^2 + 64x + 7x^2 - 6x - 8$$

$$28x^4 - 24x^3 - 56x^3 - 32x^2 + 48x^2 + 7x^2 + 64x - 6x - 8$$

$$28x^4 - 80x^3 + 23x^2 + 58x - 8$$

37.

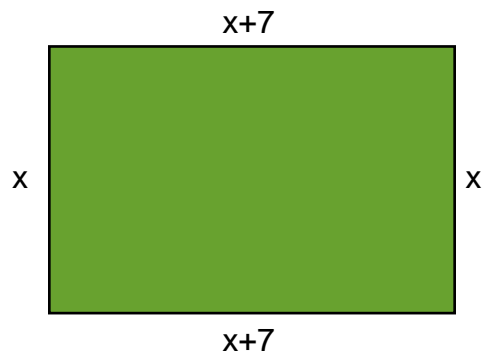

$$P = w + w + l + l$$

$$P = 65$$

$$x + x + (x + 7) + (x + 7) = 65$$

$$x + x + x + 7 + x + 7 = 65$$

$$4x + 14 = 65$$

$$4x = 51$$

$$x = 12.75$$

$$A = l(w)$$

$$A = (12.75 + 7)(12.75)$$

$$A = 19.75(12.75)$$

$$A = 251.8125$$

The dimensions are 12.75 yards and 19.75 yards.

Lesson 12.5
Multiplication and Division of Rational Expressions

1.

$$\frac{x^3}{2y^3} \cdot \frac{2y^2}{x} = \frac{2x^3y^2}{2xy^3} = \frac{x^2}{y}$$

2.

$$2xy \div \frac{2x^2}{y} = \frac{2xy}{1} \div \frac{2x^2}{y} = \frac{2xy}{1} \times \frac{y}{2x^2} = \frac{2xy^2}{2x^2} = \frac{y^2}{x}$$

3.

$$\frac{2x}{y^2} \cdot \frac{4y}{5x} = \frac{8xy}{5xy^2} = \frac{8}{5y}$$

4.

$$2xy \cdot \frac{2y^2}{x^3} = \frac{4xy^3}{x^3} = \frac{4y^3}{x^2}$$

5.

$$\frac{4y^2-1}{y^2-9} \cdot \frac{y-3}{2y-1} = \frac{(2y-1)(2y+1)}{(y-3)(y+3)} \cdot \frac{y-3}{2y-1} = \frac{2y+1}{y+3}$$

6.

$$\frac{6ab}{a^2} \cdot \frac{a^3b}{3b^2} = \frac{6a^4b^2}{3a^2b^2} = 2a^2$$

7.

$$\frac{x^2}{x-1} \div \frac{x}{x^2+x-2} = \frac{x^2}{x-1} \cdot \frac{x^2+x-2}{x} = \frac{x^2}{x-1} \cdot \frac{(x+2)(x-1)}{x} = \frac{x^2(x+2)}{x} = x(x+2) = x^2 + 2x$$

8.

$$\frac{33a^2}{-5} \cdot \frac{20}{11a^3} = \frac{660a^2}{-55a^3} = -\frac{12}{a}$$

9.

$$\frac{a^2 + 2ab + b^2}{ab^2 - a^2b} \div (a+b) = \frac{a^2 + 2ab + b^2}{ab^2 - a^2b} \times \frac{1}{a+b} = \frac{(a+b)(a+b)}{ab(b-a)} \times \frac{1}{a+b} = \frac{a+b}{ab(b-a)}$$

10.

$$\frac{2x^2 + 2x - 24}{x^2 + 3x} \cdot \frac{x^2 + x - 6}{x+4} = \frac{2(x+4)(x-3)}{x(x+3)} \cdot \frac{(x+3)(x-2)}{x+4} = \frac{2(x-3)(x-2)}{x(x+4)} = \frac{2x^2 - 10x + 12}{x^2 + 4x}$$

11.

$$\frac{3-x}{3x-5} \div \frac{x^2-9}{2x^2-8x-10} = \frac{3-x}{3x-5} \times \frac{2x^2-8x-10}{x^2-9} = \frac{3-x}{3x-5} \times \frac{2(x-5)(x+1)}{(x+3)(x-3)} = \frac{2(x-5)(x+1)(3-x)}{(x+3)(x-3)(3x-5)} = \frac{-2x^3 - 2x^2 - 34x - 30}{3x^3 - 5x^2 - 27x + 45}$$

12.

$$\frac{x^2 - 25}{x+3} \div (x-5) = \frac{(x+5)(x-5)}{x+3} \times \frac{1}{x-5} = \frac{x+5}{x+3}$$

13.

$$\frac{2x+1}{2x-1} \div \frac{4x^2-1}{1-2x} = \frac{2x+1}{2x-1} \times \frac{1-2x}{4x^2-1} = \frac{2x+1}{2x-1} \times \frac{1-2x}{(2x+1)(2x-1)} = \frac{1-2x}{(2x-1)(2x-1)} = \frac{1-2x}{4x^2-4x-1}$$

14.

$$\frac{x}{x-5} \cdot \frac{x^2-8x+15}{x^2-3x} = \frac{x}{x-5} \cdot \frac{(x-5)(x-3)}{x(x-3)} = 1$$

15.

$$\frac{3x^2+5x-12}{x^2-9} \div \frac{3x-4}{3x+4} = \frac{(3x-4)(x+3)}{(x+3)(x-3)} \times \frac{3x+4}{3x-4} = \frac{3x+4}{x-3}$$

16.

$$\frac{5x^2+16x+3}{36x^2-25} \cdot (6x^2+5x) = \frac{5x^2+16x+3}{(6x-5)(6x+5)} \cdot \frac{x(6x+5)}{1} = \frac{x(5x^2+16x+3)}{6x-5} = \frac{5x^3+16x^2+3x}{6x-5}$$

17.

$$\frac{x^2 + 7x + 10}{x^2 - 9} \cdot \frac{x^2 - 3x}{3x^2 + 4x - 4} = \frac{(x+5)(x+2)}{(x-3)(x+3)} \cdot \frac{x(x-3)}{(3x-2)(x+2)} = \frac{x(x+5)}{(x+3)(3x-2)} = \frac{x^2 + 5x}{3x^2 + 7x - 6}$$

18.

$$\frac{x^2 + x - 12}{x^2 + 4x + 4} \div \frac{x-3}{x+2} = \frac{(x+4)(x-3)}{(x+2)(x+2)} \times \frac{x+2}{x-3} = \frac{(x+4)}{(x+2)}$$

19.

$$\frac{x^4 - 16}{x^2 - 9} \div \frac{x^2 + 4}{x^2 + 6x + 9} = \frac{(x^2 + 4)(x^2 - 4)}{(x+3)(x-3)} \times \frac{(x+3)(x+3)}{x^2 + 4} = \frac{(x^2 - 4)(x+3)}{(x-3)} = \frac{x^3 + 3x^2 - 4x - 12}{x-3}$$

20.

$$\frac{x^2 + 8x + 16}{7x^2 + 9x + 2} \times \frac{7x + 2}{x^2 + 4x} = \frac{(x+4)(x+4)}{(7x+2)(x+1)} \times \frac{7x+2}{x(x+4)} = \frac{x+4}{x(x+1)} = \frac{x+4}{x^2 + x}$$

21.

$$\text{sugar} = s$$

$$\text{flour} = f$$

$$\frac{\frac{5}{2}f}{s} \times \frac{\frac{10}{3}}{\frac{10}{3}} = \frac{5f}{3\frac{1}{3}s}$$

22.

$$\frac{x}{15x} = \frac{1}{15}$$

23.

$$I = \frac{V}{R_c}$$

$$\frac{1}{R_{tot}} = \frac{1}{R_1} + \frac{1}{R_2}$$

$$R_c = R_{tot}$$

$$I = \frac{V}{\left(\frac{1}{R_1} + \frac{1}{R_2}\right)^{-1}}$$

Mixed Review

24.

$$t = \frac{k}{s}$$

$$3.6 = \frac{k}{65}$$

$$k = 234$$

$$t = \frac{234}{78}$$

$$t = 3$$

It would take 3 hours.

25.

Let the number of arrangements of the the first type be x and that of the second type be y .

The total number of mums used is $8x + 6y$

The total number of black-eyed susans is $5x + 9y$

$$\begin{cases} 8x + 6y \leq 144 \\ 5x + 9y \leq 135 \end{cases}$$

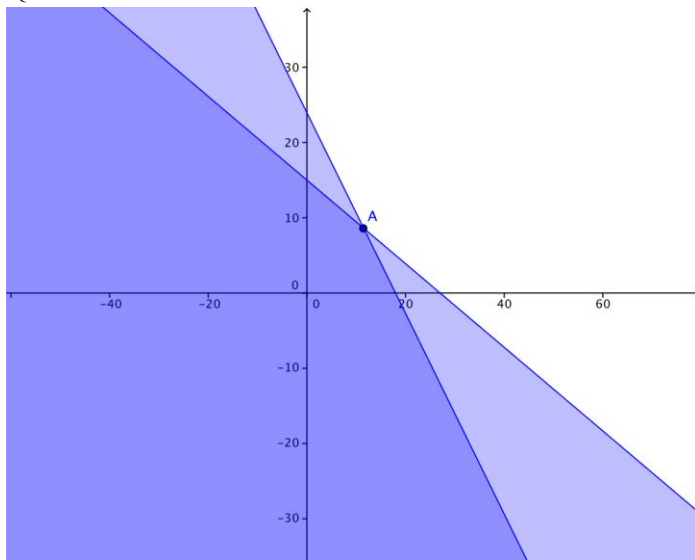

If $x = 9$ and $y = 10$ both the conditions are fulfilled.

$$8x + 6y \leq 144$$

$$8(9) + 6(10) \leq 144$$

$$72 + 60 \leq 144$$

$$\underline{132 \leq 144}$$

$$5x + 9y \leq 135$$

$$5(9) + 9(10) \leq 135$$

$$45 + 90 \leq 135$$

$$135 \leq 135$$

$$R = 49.99x + 38.95y$$

$$R = 49.99(9) + 38.95(10)$$

$$R = 449.91 + 389.50$$

The revenue is $R = \$839.41$

$$R = 49.99x + 38.95y$$

$$R = 49.99(10) + 38.95(9)$$

$$R = 499.90 + 350.55$$

If x is made 10, only 9 of y can be made but the revenue is increased $R = \$850.45$

To maximize revenue the nursery should sell 10 of the first arrangement and 9 of the second arrangement.

26.

$$-24 \geq |2r + 3|$$

No Solution (an absolute value cannot be negative, or less than a negative)

27.

$$5x + 9y = -36$$

$$9y = -5x - 36$$

$$y = -\frac{5}{9}x - 4$$

$$m = -\frac{5}{9}$$

Since parallel lines have the same slope, a line parallel to $5x + 9y = -36$ has a slope of $-5/9$.

28.

$$3 + 5d = -d - (3x - 3)$$

$$3 + 5d = -d - 3x + 3$$

$$6d = -3x$$

$$d = -0.5x$$

29. $y - 9 = -x^2 - 5x$

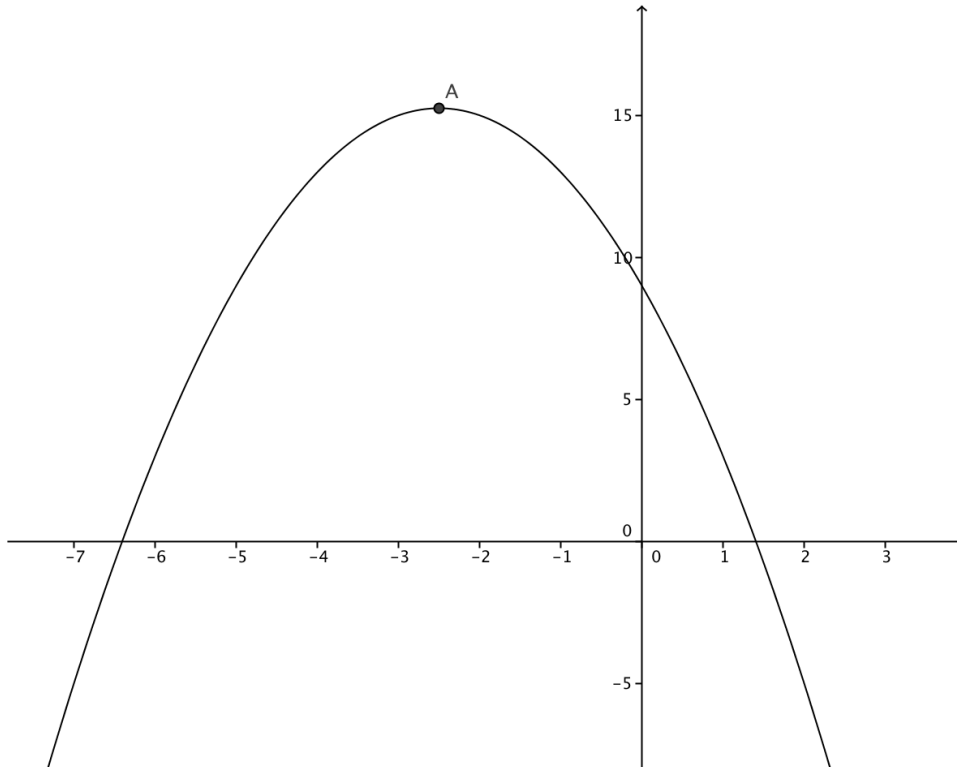

Domain: $x =$ all real numbers

Range: $y \leq 15.25$

30.

$$y^2 - 16y + 3 = 4$$

$$y^2 - 16y = 1$$

$$y^2 - 16y + 64 = 1 + 64$$

$$(y - 8)^2 = 65$$

$$x = (y - 8)^2 - 65$$

$$y = a(x - h)^2 + k$$

$$(h, k) = (8, -65)$$

Quick Quiz

1.

$$h = \frac{k}{t}$$

$$-16 = \frac{k}{-0.05153}$$

$$k = 0.82448$$

$$1.45 = \frac{0.82448}{t}$$

$$1.45t = 0.82448$$

$$t \approx 0.5686$$

2. $f(x) = \frac{-5}{x^2 - 25}$

1.

$$x^2 - 25 = 0$$

$$(x + 5)(x - 5) = 0$$

$$x + 5 = 0$$

$$x = -5$$

$$x - 5 = 0$$

$$x = 5$$

$$x = -5, 5$$

2.
 $x=5$
 $x=-5$

3.

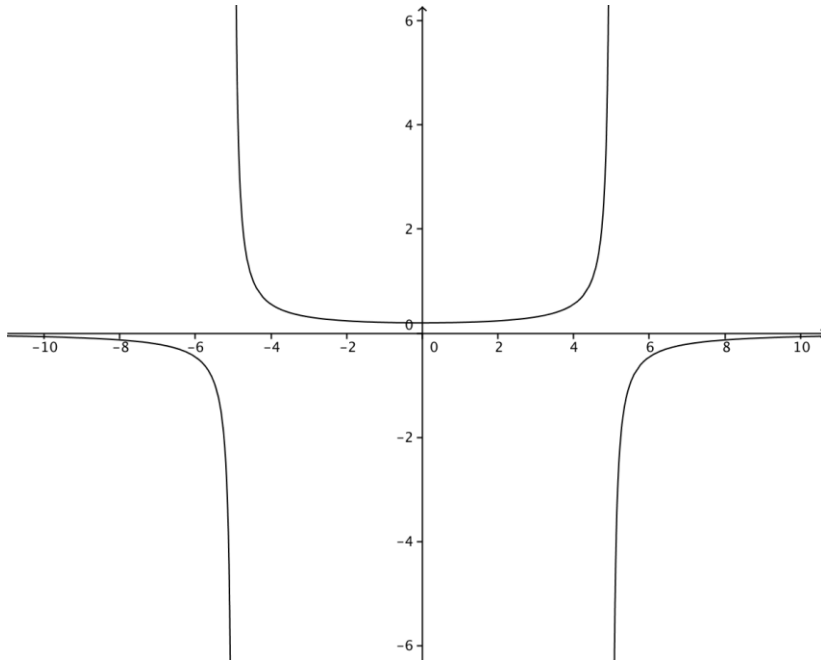

4.
Domain: $x \neq 5, x \neq -5$
Range: $y \neq 0$

Lesson 12.6

Addition and Subtraction of Rational Expressions

1.

$$\frac{5}{24} - \frac{7}{24} = \frac{-2}{24} = \frac{-1}{12}$$

2.

$$\frac{10}{21} + \frac{9}{35} = \frac{50}{105} + \frac{27}{105} = \frac{77}{105} = \frac{11}{15}$$

3.

$$\frac{5}{2x+3} + \frac{2}{2x+3} = \frac{7}{2x+3}$$

4.

$$\frac{3x-1}{x+9} - \frac{4x+3}{x+9} = \frac{-x-4}{x+9} = \frac{-(x+4)}{x+9}$$

5.

$$\frac{4x+7}{2x^2} - \frac{3x-4}{2x^2} = \frac{x+11}{2x^2}$$

6.

$$\frac{x^2}{x+5} - \frac{25}{x+5} = \frac{x^2-25}{x+5} = \frac{(x+5)(x-5)}{x+5} = x-5$$

7.

$$\frac{2x}{x-4} + \frac{x}{4-x} = \frac{2x}{x-4} + \frac{x}{4-x} \cdot \frac{-1}{-1} = \frac{2x}{x-4} + \frac{-x}{x-4} = \frac{x}{x-4}$$

8.

$$\frac{10}{3x-1} - \frac{7}{1-3x} = \frac{10}{3x-1} - \frac{7}{1-3x} \cdot \frac{-1}{-1} = \frac{10}{3x-1} - \frac{-7}{3x-1} = \frac{17}{3x-1}$$

9.

$$\frac{5}{2x+3} - 3 = \frac{5}{2x+3} - 3 \cdot \frac{2x+3}{2x+3} = \frac{5}{2x+3} - \frac{3(2x+3)}{2x+3} = \frac{5}{2x+3} - \frac{6x+9}{2x+3} = \frac{-6x-4}{2x+3}$$

10.

$$\frac{5x+1}{x+4} + 2 = \frac{5x+1}{x+4} + 2 \cdot \frac{x+4}{x+4} = \frac{5x+1}{x+4} + \frac{2(x+4)}{x+4} = \frac{5x+1}{x+4} + \frac{2x+8}{x+4} = \frac{7x+9}{x+4}$$

11.

$$\frac{1}{x} + \frac{2}{3x} = \frac{3}{3} \cdot \frac{1}{x} + \frac{2}{3x} = \frac{3}{3x} + \frac{2}{3x} = \frac{5}{3x}$$

12.

$$\frac{4}{5x^2} - \frac{2}{7x^3} = \frac{4}{5x^2} \cdot \frac{7x}{7x} - \frac{2}{7x^3} \cdot \frac{5}{5} = \frac{28x}{35x^3} - \frac{10}{35x^3} = \frac{28x-10}{35x^3}$$

13.

$$\frac{4x}{x+1} - \frac{2}{2(x+1)} = \frac{4x}{x+1} \cdot \frac{2}{2} - \frac{2}{2(x+1)} = \frac{8x}{2(x+1)} - \frac{2}{2(x+1)} = \frac{8x-2}{2(x+1)} = \frac{2(4x-1)}{2(x+1)} = \frac{4x-1}{x+1}$$

14.

$$\frac{10}{x+5} + \frac{2}{x+2} = \frac{10}{x+5} \cdot \frac{x+2}{x+2} + \frac{2}{x+2} \cdot \frac{x+5}{x+5} = \frac{10(x+2)}{(x+5)(x+2)} + \frac{2(x+5)}{(x+2)(x+5)} = \frac{10x+20}{(x+5)(x+2)} + \frac{2x+10}{(x+2)(x+5)} = \frac{12x+30}{(x+2)(x+5)} = \frac{6(2x+5)}{(x+2)(x+5)}$$

15.

$$\begin{aligned} \frac{2x}{x-3} - \frac{3x}{x+4} &= \\ \frac{2x}{x-3} \cdot \frac{x+4}{x+4} - \frac{3x}{x+4} \cdot \frac{x-3}{x-3} &= \\ \frac{2x(x+4)}{(x-3)(x+4)} - \frac{3x(x-3)}{(x-3)(x+4)} &= \\ \frac{2x^2+8x}{(x-3)(x+4)} - \frac{3x^2-9x}{(x-3)(x+4)} &= \\ \frac{-x^2+17x}{(x-3)(x+4)} & \end{aligned}$$

16.

$$\begin{aligned} & \frac{4x-3}{2x+1} + \frac{x+2}{x-9} \\ & \frac{4x-3}{2x+1} \cdot \frac{x-9}{x-9} + \frac{x+2}{x-9} \cdot \frac{2x+1}{2x+1} \\ & \frac{(4x-3)(x-9)}{(2x+1)(x-9)} + \frac{(x+2)(2x+1)}{(2x+1)(x-9)} \\ & \frac{4x^2 - 39x + 27}{(2x+1)(x-9)} + \frac{2x^2 + 5x + 2}{(2x+1)(x-9)} \\ & \frac{6x^2 - 34x + 29}{(2x+1)(x-9)} \end{aligned}$$

17.

$$\begin{aligned} & \frac{x^2}{x+4} - \frac{3x^2}{4x-1} \\ & \frac{x^2}{x+4} \cdot \frac{4x-1}{4x-1} - \frac{3x^2}{4x-1} \cdot \frac{x+4}{x+4} \\ & \frac{x^2(4x-1)}{(x+4)(4x-1)} - \frac{3x^2(x+4)}{(x+4)(4x-1)} \\ & \frac{4x^3 - x^2}{(x+4)(4x-1)} - \frac{3x^3 + 12x^2}{(x+4)(4x-1)} \\ & \frac{x^3 - 13x^2}{(x+4)(4x-1)} \end{aligned}$$

18.

$$\begin{aligned} & \frac{2}{5x+2} - \frac{x+1}{x^2} \\ & \frac{2}{5x+2} \cdot \frac{x^2}{x^2} - \frac{x+1}{x^2} \cdot \frac{5x+2}{5x+2} \\ & \frac{2x^2}{x^2(5x+2)} - \frac{(x+1)(5x+2)}{x^2(5x+2)} \\ & \frac{2x^2}{x^2(5x+2)} - \frac{5x^2 + 7x + 2}{x^2(5x+2)} \\ & \frac{-3x^2 - 7x - 2}{x^2(5x+2)} \end{aligned}$$

19.

$$\begin{aligned} & \frac{x+4}{2x} + \frac{2}{9x} \\ & \frac{x+4}{2x} \cdot \frac{9}{9} + \frac{2}{9x} \cdot \frac{2}{2} \\ & \frac{9(x+4)}{18x} + \frac{2(2)}{18x} \\ & \frac{9x+36}{18x} + \frac{4}{18x} \\ & \frac{9x+40}{18x} \end{aligned}$$

20.

$$\begin{aligned} & \frac{5x+3}{x^2+x} + \frac{2x+1}{x} \\ & \frac{5x+3}{x(x+1)} + \frac{2x+1}{x} \cdot \frac{x+1}{x+1} \\ & \frac{5x+3}{x(x+1)} + \frac{(2x+1)(x+1)}{x(x+1)} \\ & \frac{5x+3}{x(x+1)} + \frac{2x^2+3x+1}{x(x+1)} \\ & \frac{2x^2+8x+4}{x(x+1)} \end{aligned}$$

21.

$$\begin{aligned} & \frac{4}{(x+1)(x-1)} - \frac{5}{(x+1)(x+2)} \\ & \frac{4}{(x+1)(x-1)} \cdot \frac{x+2}{x+2} - \frac{5}{(x+1)(x+2)} \cdot \frac{x-1}{x-1} \\ & \frac{4(x+2)}{(x+1)(x-1)(x+2)} - \frac{5(x-1)}{(x+1)(x-1)(x+2)} \\ & \frac{4x+8}{(x+1)(x-1)(x+2)} - \frac{5x-5}{(x+1)(x-1)(x+2)} \\ & \frac{-x+13}{(x+1)(x-1)(x+2)} \end{aligned}$$

22.

$$\begin{aligned} & \frac{2x}{(x+2)(3x-4)} + \frac{7x}{(3x-4)^2} \\ & \frac{2x}{(x+2)(3x-4)} \cdot \frac{3x-4}{3x-4} + \frac{7x}{(3x-4)^2} \cdot \frac{x+2}{x+2} \\ & \frac{2x(3x-4)}{(x+2)(3x-4)^2} + \frac{7x(x+2)}{(x+2)(3x-4)^2} \\ & \frac{6x^2 - 8x}{(x+2)(3x-4)^2} + \frac{7x^2 + 14x}{(x+2)(3x-4)^2} \\ & \frac{13x^2 + 6x}{(x+2)(3x-4)^2} \end{aligned}$$

23.

$$\begin{aligned} & \frac{3x+5}{x(x-1)} - \frac{9x-1}{(x-1)^2} \\ & \frac{3x+5}{x(x-1)} \cdot \frac{x-1}{x-1} - \frac{9x-1}{(x-1)^2} \cdot \frac{x}{x} \\ & \frac{(3x+5)(x-1)}{x(x-1)^2} - \frac{x(9x-1)}{x(x-1)^2} \\ & \frac{3x^2 + 2x - 5}{x(x-1)^2} - \frac{9x^2 - x}{x(x-1)^2} \\ & \frac{-6x^2 + 3x - 5}{x(x-1)^2} \end{aligned}$$

24.

$$\begin{aligned} & \frac{1}{(x-2)(x-3)} + \frac{4}{(2x+5)(x-6)} \\ & \frac{1}{(x-2)(x-3)} \cdot \frac{(2x+5)(x-6)}{(2x+5)(x-6)} + \frac{4}{(2x+5)(x-6)} \cdot \frac{(x-2)(x-3)}{(x-2)(x-3)} \\ & \frac{1(2x+5)(x-6)}{(x-2)(x-3)(2x+5)(x-6)} + \frac{4(x-2)(x-3)}{(x-2)(x-3)(2x+5)(x-6)} \\ & \frac{2x^2 - 7x - 30}{(x-2)(x-3)(2x+5)(x-6)} + \frac{4x^2 - 20x + 24}{(x-2)(x-3)(2x+5)(x-6)} \\ & \frac{6x^2 - 27x - 6}{(x-2)(x-3)(2x+5)(x-6)} \end{aligned}$$

25.

$$\frac{3x-2}{x-2} + \frac{1}{x^2-4x+4}$$

$$\frac{3x-2}{x-2} + \frac{1}{(x-2)^2}$$

$$\frac{3x-2}{x-2} \cdot \frac{x-2}{x-2} + \frac{1}{(x-2)^2}$$

$$\frac{3x^2-8x+4}{(x-2)^2} + \frac{1}{(x-2)^2}$$

$$\frac{3x^2-8x+5}{(x-2)^2}$$

26.

$$\frac{-x^2}{x^2-7x+6} + x-4$$

$$\frac{-x^2}{(x-6)(x-1)} + \frac{(x-4)(x-6)(x-1)}{(x-6)(x-1)}$$

$$\frac{-x^2}{(x-6)(x-1)} + \frac{x^3-11x^2+34x-24}{(x-6)(x-1)}$$

$$\frac{x^3-12x^2+34x-24}{(x-6)(x-1)}$$

27.

$$\begin{aligned} & \frac{2x}{x^2+10x+25} - \frac{3x}{2x^2+7x-15} \\ & \frac{2x}{(x+5)(x+5)} - \frac{3x}{(2x-3)(x+5)} \\ & \frac{2x}{(x+5)(x+5)} \cdot \frac{2x-3}{2x-3} - \frac{3x}{(2x-3)(x+5)} \cdot \frac{x+5}{x+5} \\ & \frac{2x(2x-3)}{(2x-3)(x+5)^2} - \frac{3x(x+5)}{(2x-3)(x+5)^2} \\ & \frac{4x^2-6x}{(2x-3)(x+5)^2} - \frac{3x^2+15x}{(2x-3)(x+5)^2} \\ & \frac{x^2-21x}{(2x-3)(x+5)^2} \end{aligned}$$

28.

$$\begin{aligned} & \frac{1}{x^2-9} + \frac{2}{x^2+5x+6} \\ & \frac{1}{(x+3)(x-3)} + \frac{2}{(x+3)(x+2)} \\ & \frac{1}{(x+3)(x-3)} \cdot \frac{x+2}{x+2} + \frac{2}{(x+3)(x+2)} \cdot \frac{x-3}{x-3} \\ & \frac{x+2}{(x+3)(x-3)(x+2)} + \frac{2x-6}{(x+3)(x-3)(x+2)} \\ & \frac{3x-4}{(x+3)(x-3)(x+2)} \end{aligned}$$

29.

$$\begin{aligned}
 & \frac{-x+4}{2x^2-x-15} + \frac{x}{4x^2+8x-5} \\
 & \frac{-x+4}{(2x+5)(x-3)} + \frac{x}{(2x+5)(2x-1)} \\
 & \frac{-x+4}{(2x+5)(x-3)} \cdot \frac{2x-1}{2x-1} + \frac{x}{(2x+5)(2x-1)} \cdot \frac{x-3}{x-3} \\
 & \frac{-x+4(2x-1)}{(2x+5)(2x-1)(x-3)} + \frac{x(x-3)}{(2x+5)(2x-1)(x-3)} \\
 & \frac{-2x^2+9x-4}{(2x+5)(2x-1)(x-3)} + \frac{x^2-3x}{(2x+5)(2x-1)(x-3)} \\
 & \frac{-x^2+6x-4}{(2x+5)(2x-1)(x-3)}
 \end{aligned}$$

30.

$$\begin{aligned}
 & \frac{4}{9x^2-49} - \frac{1}{3x^2+5x-28} \\
 & \frac{4}{(3x-7)(3x+7)} - \frac{1}{(3x-7)(x+4)} \\
 & \frac{4}{(3x-7)(3x+7)} \cdot \frac{x+4}{x+4} - \frac{1}{(3x-7)(x+4)} \cdot \frac{3x+7}{3x+7} \\
 & \frac{4x+16}{(3x-7)(3x+7)(x+4)} - \frac{3x+7}{(3x-7)(3x+7)(x+4)} \\
 & \frac{x+9}{(3x-7)(3x+7)(x+4)}
 \end{aligned}$$

31.

x

$x - 5$

$$\frac{1}{x} + \frac{1}{x-5} = \frac{13}{36}$$

$$\frac{1}{x} \cdot \frac{x(x-5)}{x(x-5)} + \frac{1}{x-5} \cdot \frac{x(x-5)}{x(x-5)} = \frac{13}{36}$$

$$\frac{x-5}{x(x-5)} + \frac{x}{x(x-5)} = \frac{13}{36}$$

$$\frac{x-5+x}{x(x-5)} = \frac{13}{36}$$

$$\frac{2x-5}{x(x-5)} = \frac{13}{36}$$

$$36(2x-5) = 13 \cdot x(x-5)$$

$$72x - 180 = 13 \cdot x^2 - 5x$$

$$72x - 180 = 13x^2 - 65x$$

$$0 = 13x^2 - 65x - 72x + 180$$

$$0 = 13x^2 - 137x + 180$$

$$x = \frac{-b \pm \sqrt{b^2 - 4ac}}{2a}$$

$$x = \frac{-(-137) \pm \sqrt{(-137)^2 - 4(13)(180)}}{2(13)}$$

$$x = \frac{137 \pm \sqrt{18769 - 9360}}{26}$$

$$x = \frac{137 \pm \sqrt{9409}}{26}$$

$$x = \frac{137 + \sqrt{9409}}{26} = \frac{137 + 97}{26} = \frac{234}{26} = 9$$

$$x = \frac{137 - \sqrt{9409}}{26} = \frac{137 - 97}{26} = \frac{40}{26} \approx 1.5385$$

The numbers can be 9 and 4 or 1.5385 and -3.4615.

32.

x

$8x$

$$\frac{1}{x} - \frac{1}{8x} = \frac{21}{20}$$

$$\frac{1}{x} \cdot \frac{8}{8} - \frac{1}{8x} = \frac{21}{20}$$

$$\frac{8}{8x} - \frac{1}{8x} = \frac{21}{20}$$

$$\frac{7}{8x} = \frac{21}{20}$$

$$7(20) = 21(8x)$$

$$140 = 168x$$

$$x = \frac{140}{168} = \frac{5}{6}$$

The two numbers are $5/6$ and $20/3$.

33.

The first pipe fills the tank in 4 hours.

In one hour it fills $1/4$ of the tank.

The second pipe empties the tank in 8 hours.

In one hour it empties $1/8$ of the tank.

For the first pipe: time X rate of work equals $t * \frac{1}{4} = \frac{t}{4}$

For the second pipe: time X rate of work equals $t * \frac{1}{8} = \frac{t}{8}$

$$\frac{t}{4} - \frac{t}{8} = 1$$

$$\frac{2t}{8} - \frac{t}{8} = 1$$

$$\frac{2t - t}{8} = 1$$

$$\frac{t}{8} = 1$$

Since one pipe is filling and one pipe is emptying, subtract: $t = 8$

With both pipes open it will take 8 hours to fill the tank.

34.

Stefan could do the whole work in 6 hrs.

In one hour he can do $\frac{1}{6}$ of the work.

Misha could do the whole work in 5 hrs.

In one hour he can do $\frac{1}{5}$ of the work.

Stefan works for 2.5 hours: time X rate of work equals $2.5 * \frac{1}{6} = \frac{2.5}{6} = \frac{25}{60}$

When he finished the amount of work left equals $1 - \frac{25}{60} = \frac{60}{60} - \frac{25}{60} = \frac{35}{60}$

Now Misha has the remaining work divided by his rate of work $\frac{35}{60} \div \frac{1}{5} = \frac{35}{60} * \frac{5}{1} = \frac{175}{60} = 2.9167$

It takes Misha 2 hours and 55 minutes to finish washing the cars.

35.

Amanda can clear the snow in 3 hours.

In one hour she can clear $\frac{1}{3}$ of the driveway.

Chyna can clear the snow in 4 hours.

In one hour she can clear $\frac{1}{4}$ of the driveway.

Amanda works for one hour: time X rate of work equals $1 * \frac{1}{3} = \frac{1}{3}$

After that first hour the amount of work left equals $1 - \frac{1}{3} = \frac{3}{3} - \frac{1}{3} = \frac{2}{3}$

Now the two girls work together $\frac{1}{3} + \frac{1}{4} = \frac{4}{12} + \frac{3}{12} = \frac{7}{12}$

And we divide the remaining work by the rate when they work together:

$$\frac{2}{3} \div \frac{7}{12} = \frac{2}{3} * \frac{12}{7} = \frac{24}{7} = 3.4286$$

Add this to the hour that Amanda worked alone. It takes approximately 2 hours and 8 minutes.

36.

The first machine can finish the work in 10 hours.

In one hour it can do $\frac{1}{10}$ of the work.

The second machine can finish the work in 14 hours.

In one hour it can do $\frac{1}{14}$ of the work.

For the first 4 hours the machines work together: time X rate of work equals

$$4 * \left(\frac{1}{10} + \frac{1}{14} \right) = 4 * \left(\frac{14}{140} + \frac{10}{140} \right) = 4 * \left(\frac{24}{140} \right) = \frac{96}{140}$$

When the second machine breaks the amount of work left equals: $1 - \frac{96}{140} = \frac{140}{140} - \frac{96}{140} = \frac{44}{140}$

Now the first machine has the remaining work divided by its rate of work

$$\frac{44}{140} \div \frac{1}{10} = \frac{44}{140} \times \frac{10}{1} = \frac{440}{140} = 3.14$$

The fast machine works for approximately 3 hours and 8 minutes to finish the quota.

Mixed Review

37.

In the first situation the population is increasing mathematically by 500 people each year regardless of the size at the time, while in the second situation the population is increasing by 5% each year, meaning that each year it increases by 5% of the current population, increasing by a larger amount each year.

1.
 $P = p + 500t$

$$p = 10,000$$

$$t = 7$$

2.

$$P = p(1.05)^x$$

$$p = 10,000$$

$$x = 7$$

Statement 2 becomes larger than statement one by the second year.

38.

$$\frac{16x^2y^7}{-2x^8y} \cdot \frac{1}{2}x^{-10} = \frac{16x^2y^7}{-2x^8y} \cdot \frac{1}{2x^{10}} = \frac{16x^2y^7}{-4x^{18}y} = -\frac{4y^6}{x^{16}}$$

39.

$$-12 = j^2 - 8j$$

$$j^2 - 8j + 12 = 0$$

$$(j - 6)(j - 2) = 0$$

$$j - 6 = 0$$

$$j = 6$$

$$j - 2 = 0$$

$$j = 2$$

$$j = 2, j = 6$$

Factoring is the most obvious method (since the equation factors so easily) but any method used correctly would be acceptable.

40.

1.

$$h(t) = -\frac{1}{2}(g)t^2 + v_0t + h_0$$

$$h(t) = -\frac{1}{2}(32)t^2 + 12t + 4$$

$$h(t) = -16t^2 + 12t + 4$$

2.

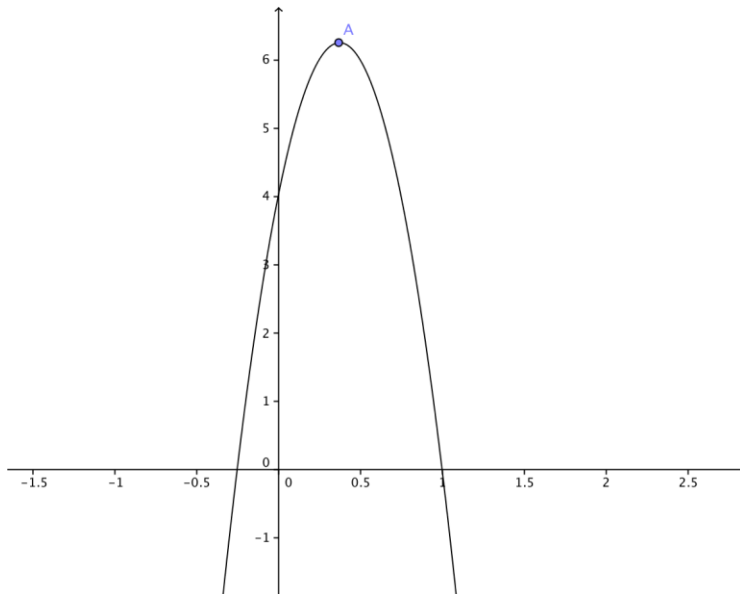

41.

$$\frac{d}{s} = \frac{245}{5} = \frac{90}{x} =$$

$$245x = 450$$

$$x = 1.8367$$

42.

$$3.78 \div \frac{1}{2} = 7.56$$

$$7.56 \cdot 14 = 105.84$$

The true distance is 105.84 miles.

Lesson 12.7
Solution of Rational Equations

1.

$$\frac{2x+1}{4} = \frac{x-3}{10}$$

$$10(2x+1) = 4(x-3)$$

$$20x+10 = 4x-12$$

$$16x = -22$$

$$x = -\frac{22}{16} = -\frac{11}{8}$$

2.

$$\frac{4x}{x+2} = \frac{5}{9}$$

$$4x(9) = 5(x+2)$$

$$36x = 5x+10$$

$$31x = 10$$

$$x = \frac{10}{31}$$

3.

$$\frac{5}{3x-4} = \frac{2}{x+1}$$

$$5(x+1) = 2(3x-4)$$

$$5x+5 = 6x-8$$

$$-x = -13$$

$$x = 13$$

4.

$$\frac{7x}{x-5} = \frac{x+3}{x}$$

$$7x(x) = (x+3)(x-5)$$

$$7x^2 = x^2 - 5x + 3x - 15$$

$$6x^2 - 2x - 15 = 0$$

$$x = \frac{-b \pm \sqrt{b^2 - 4ac}}{2a}$$

$$x = \frac{-(-2) \pm \sqrt{(-2)^2 - 4(6)(-15)}}{2(6)}$$

$$x = \frac{2 \pm \sqrt{4 + 360}}{12}$$

$$x = \frac{2 \pm \sqrt{364}}{12}$$

$$x = \frac{2 + \sqrt{364}}{12} \approx \frac{2 + 19.0788}{12} \approx \frac{21.0788}{12} \approx 1.7566$$

$$x = \frac{2 - \sqrt{364}}{12} \approx \frac{2 - 19.0788}{12} \approx \frac{-17.0788}{12} \approx -1.4232$$

5.

$$\frac{2}{x+3} - \frac{1}{x+4} = 0$$

$$\frac{2}{x+3} = \frac{1}{x+4}$$

$$2(x+4) = 1(x+3)$$

$$2x + 8 = x + 3$$

$$x = -5$$

6.

$$\frac{3x^2 + 2x - 1}{x^2 - 1} = -2$$

$$\frac{(3x-1)(x+1)}{(x+1)(x-1)} = -2$$

$$\frac{3x-1}{x-1} = -2$$

$$3x-1 = -2(x-1)$$

$$3x-1 = -2x+2$$

$$5x = 3$$

$$x = \frac{3}{5} = 0.6$$

7.

$$x + \frac{1}{x} = 2$$

$$x \cdot \frac{x}{x} + \frac{1}{x} = 2$$

$$\frac{x^2}{x} + \frac{1}{x} = 2$$

$$\frac{x^2 + 1}{x} = 2$$

$$x^2 + 1 = 2x$$

$$x^2 - 2x + 1 = 0$$

$$(x-1)(x-1) = 0$$

$$x-1 = 0$$

$$x = 1$$

8.

$$\frac{1}{x+1} - \frac{2}{x-1} = 3$$

$$\frac{1}{x+1} \cdot \frac{x-1}{x-1} - \frac{2}{x-1} \cdot \frac{x+1}{x+1} = 3$$

$$\frac{x-1}{(x-1)(x+1)} - \frac{2(x+1)}{(x-1)(x+1)} = 3$$

$$\frac{x-1-2x-2}{(x-1)(x+1)} = 3$$

$$\frac{-x-3}{(x-1)(x+1)} = 3$$

$$-x-3 = 3[(x-1)(x+1)]$$

$$-x-3 = 3(x^2-1)$$

$$-x-3 = 3x^2-3$$

$$0 = 3x^2+x$$

$$0 = x(3x+1)$$

$$x = 0$$

$$3x+1 = 0$$

$$3x = -1$$

$$x = -\frac{1}{3}$$

$$x = 0, x = -\frac{1}{3}$$

9.

$$\frac{1}{x} - \frac{x}{x-2} = 2$$

$$\frac{1}{x} \cdot \frac{x-2}{x-2} - \frac{x}{x-2} \cdot \frac{x}{x} = 2$$

$$\frac{x-2}{x(x-2)} - \frac{x^2}{x(x-2)} = 2$$

$$\frac{x-2-x^2}{x(x-2)} = 2$$

$$\frac{-x^2+x-2}{x(x-2)} = 2$$

$$-x^2+x-2 = 2[x(x-2)]$$

$$-x^2+x-2 = 2(x^2-2x)$$

$$-x^2+x-2 = 2x^2-4x$$

$$0 = 3x^2 - 5x + 2$$

$$0 = (3x-2)(x-1)$$

$$x-1 = 0$$

$$x = 1$$

$$3x-2 = 0$$

$$3x = 2$$

$$x = \frac{2}{3}$$

$$x = 1, x = \frac{2}{3}$$

10.

$$\frac{3}{2x-1} + \frac{2}{x+4} = 2$$

$$\frac{3}{2x-1} \cdot \frac{x+4}{x+4} + \frac{2}{x+4} \cdot \frac{2x-1}{2x-1} = 2$$

$$\frac{3(x+4)}{(2x-1)(x+4)} + \frac{2(2x-1)}{(2x-1)(x+4)} = 2$$

$$\frac{3x+12}{(2x-1)(x+4)} + \frac{4x-2}{(2x-1)(x+4)} = 2$$

$$\frac{3x+12+4x-2}{(2x-1)(x+4)} = 2$$

$$7x+10 = 2[(2x-1)(x+4)]$$

$$7x+10 = 2(2x^2 + 7x - 4)$$

$$7x+10 = 4x^2 + 14x - 8$$

$$0 = 4x^2 + 7x - 18$$

$$x = \frac{-b \pm \sqrt{b^2 - 4ac}}{2a}$$

$$x = \frac{-7 \pm \sqrt{7^2 - 4(4)(-18)}}{2(4)}$$

$$x = \frac{-7 \pm \sqrt{49 + 288}}{8}$$

$$x = \frac{-7 \pm \sqrt{337}}{8}$$

$$x = \frac{-7 + \sqrt{337}}{8} \approx \frac{-7 + 18.3576}{8} \approx \frac{11.3576}{8} \approx 1.4197$$

$$x = \frac{-7 - \sqrt{337}}{8} \approx \frac{-7 - 18.3576}{8} \approx \frac{-25.3576}{8} \approx -3.1697$$

11.

$$\frac{2x}{x-1} - \frac{x}{3x+4} = 3$$

$$\frac{2x}{x-1} \cdot \frac{3x+4}{3x+4} - \frac{x}{3x+4} \cdot \frac{x-1}{x-1} = 3$$

$$\frac{2x(3x+4)}{(3x+4)(x-1)} - \frac{x(x-1)}{(3x+4)(x-1)} = 3$$

$$\frac{6x^2 + 8x}{(3x+4)(x-1)} - \frac{x^2 - x}{(3x+4)(x-1)} = 3$$

$$\frac{6x^2 + 8x - x^2 + x}{(3x+4)(x-1)} = 3$$

$$\frac{5x^2 + 9x}{(3x+4)(x-1)} = 3$$

$$5x^2 + 9x = 3[(3x+4)(x-1)]$$

$$5x^2 + 9x = 3(3x^2 + x - 4)$$

$$5x^2 + 9x = 9x^2 + 3x - 12$$

$$0 = 4x^2 - 6x - 12$$

$$0 = 2(2x^2 - 3x - 6)$$

$$x = \frac{-b \pm \sqrt{b^2 - 4ac}}{2a}$$

$$x = \frac{-(-3) \pm \sqrt{(-3)^2 - 4(2)(-6)}}{2(2)}$$

$$x = \frac{3 \pm \sqrt{9 + 48}}{4}$$

$$x = \frac{3 \pm \sqrt{57}}{4}$$

$$x = \frac{3 + \sqrt{57}}{4} \approx \frac{3 + 7.5498}{4} \approx \frac{10.5498}{4} \approx 2.6375$$

$$x = \frac{3 - \sqrt{57}}{4} \approx \frac{3 - 7.5498}{4} \approx \frac{-4.5498}{4} \approx -1.1375$$

12.

$$\frac{x+1}{x-1} + \frac{x-4}{x+4} = 3$$

$$\frac{x+1}{x-1} \cdot \frac{x+4}{x+4} + \frac{x-4}{x+4} \cdot \frac{x-1}{x-1} = 3$$

$$\frac{(x+1)(x+4)}{(x-1)(x+4)} + \frac{(x-4)(x-1)}{(x-1)(x+4)} = 3$$

$$\frac{x^2 + 5x + 4}{(x-1)(x+4)} + \frac{x^2 - 5x + 4}{(x-1)(x+4)} = 3$$

$$\frac{x^2 + 5x + 4 + x^2 - 5x + 4}{(x-1)(x+4)} = 3$$

$$\frac{2x^2 + 8}{(x-1)(x+4)} = 3$$

$$2x^2 + 8 = 3[(x-1)(x+4)]$$

$$2x^2 + 8 = 3(x^2 + 3x - 4)$$

$$2x^2 + 8 = 3x^2 + 9x - 12$$

$$0 = x^2 + 9x - 20$$

$$x = \frac{-b \pm \sqrt{b^2 - 4ac}}{2a}$$

$$x = \frac{-9 \pm \sqrt{9^2 - 4(1)(-20)}}{2(1)}$$

$$x = \frac{-9 \pm \sqrt{81 + 80}}{2}$$

$$x = \frac{-9 \pm \sqrt{161}}{2}$$

$$x = \frac{-9 + \sqrt{161}}{2} \approx \frac{-9 + 12.6886}{2} \approx \frac{3.6886}{2} \approx 1.8443$$

$$x = \frac{-9 - \sqrt{161}}{2} \approx \frac{-9 - 12.6886}{2} \approx \frac{-21.6886}{2} \approx -10.8443$$

13.

$$\frac{x}{x-2} + \frac{x}{x+3} = \frac{1}{x^2+x-6}$$

$$\frac{x}{x-2} + \frac{x}{x+3} = \frac{1}{(x-2)(x+3)}$$

$$(x-2)(x+3) \cdot \frac{x}{x-2} + (x-2)(x+3) \cdot \frac{x}{x+3} = (x-2)(x+3) \cdot \frac{1}{(x-2)(x+3)}$$

$$x(x+3) + x(x-2) = 1$$

$$x^2 + 3x + x^2 - 2x = 1$$

$$2x^2 + x - 1 = 0$$

$$(2x-1)(x+1) = 0$$

$$2x-1 = 0$$

$$2x = 1$$

$$x = \frac{1}{2}$$

$$x+1 = 0$$

$$x = -1$$

$$x = \frac{1}{2}, x = -1$$

14.

$$\frac{2}{x^2 + 4x + 3} = 2 + \frac{x-2}{x+3}$$

$$\frac{2}{(x+3)(x+1)} = 2 + \frac{x-2}{x+3}$$

$$(x+3)(x+1) \cdot \frac{2}{(x+3)(x+1)} = (x+3)(x+1) \cdot 2 + (x+3)(x+1) \cdot \frac{x-2}{x+3}$$

$$2 = 2[(x+3)(x+1)] + [(x+1)(x-2)]$$

$$2 = 2(x^2 + 4x + 3) + (x^2 - x - 2)$$

$$2 = 2x^2 + 8x + 6 + x^2 - x - 2$$

$$0 = 3x^2 + 7x + 2$$

$$0 = (3x+1)(x+2)$$

$$3x+1=0$$

$$3x=-1$$

$$x=-\frac{1}{3}$$

$$x+2=0$$

$$x=-2$$

$$x=-\frac{1}{3}, x=-2$$

15.

$$\frac{1}{x+5} - \frac{1}{x-5} = \frac{1-x}{x+5}$$

$$(x+5)(x-5) \cdot \frac{1}{x+5} - (x+5)(x-5) \cdot \frac{1}{x-5} = (x+5)(x-5) \cdot \frac{1-x}{x+5}$$

$$(x-5) - (x+5) = (x-5)(1-x)$$

$$x-5-x-5 = x-x^2-5+5x$$

$$0 = -x^2 + 4x - 5$$

$$0 = (x+5)(x-1)$$

$$x+5=0$$

$$x=-5$$

$$x-1=0$$

$$x=1$$

$$x=-5, x=1$$

16.

$$\frac{x}{x^2 - 36} + \frac{1}{x - 6} = \frac{1}{x + 6}$$

$$\frac{x}{(x - 6)(x + 6)} + \frac{1}{x - 6} = \frac{1}{x + 6}$$

$$(x - 6)(x + 6) \cdot \frac{x}{(x - 6)(x + 6)} + (x - 6)(x + 6) \cdot \frac{1}{x - 6} = (x - 6)(x + 6) \cdot \frac{1}{x + 6}$$

$$x + (x + 6) = x - 6$$

$$x + x + 6 = x - 6$$

$$2x + 6 = x - 6$$

$$x + 12 = 0$$

$$x = -12$$

17.

$$\frac{2x}{3x + 3} - \frac{1}{4x + 4} = \frac{2}{x + 1}$$

$$\frac{2x}{3(x + 1)} - \frac{1}{4(x + 1)} = \frac{2}{x + 1}$$

$$12(x + 1) \cdot \frac{2x}{3(x + 1)} - 12(x + 1) \cdot \frac{1}{4(x + 1)} = 12(x + 1) \cdot \frac{2}{x + 1}$$

$$4(2x) - 3 = 12(2)$$

$$8x - 3 = 24$$

$$8x = 27$$

$$x = 3.375$$

18.

$$\frac{-x}{x-2} + \frac{3x-1}{x+4} = \frac{1}{x^2+2x-8}$$

$$\frac{-x}{x-2} + \frac{3x-1}{x+4} = \frac{1}{(x-2)(x+4)}$$

$$(x-2)(x+4) \cdot \frac{-x}{x-2} + (x-2)(x+4) \cdot \frac{3x-1}{x+4} = (x-2)(x+4) \cdot \frac{1}{(x-2)(x+4)}$$

$$-x(x-4) + (3x-1)(x-2) = 1$$

$$(-x^2 + 4x) + (3x^2 - 7x + 2) = 1$$

$$-x^2 + 4x + 3x^2 - 7x + 2 = 1$$

$$2x^2 - 3x + 2 = 1$$

$$2x^2 - 3x + 1 = 0$$

$$(2x-1)(x-1) = 0$$

$$2x-1 = 0$$

$$2x = 1$$

$$x = \frac{1}{2}$$

$$x-1 = 0$$

$$x = 1$$

$$x = \frac{1}{2}, x = 1$$

19.

T = time it takes Maria to catch up to Juan

Juan's distance = $3.5(T+2)$

Maria's distance = $7T$

$$7T = 3.5(T+2)$$

$$7T = 3.5T + 7$$

$$3.5T = 7$$

$$T = 2$$

It takes Maria 2 hours to catch up so her distance will be $7\text{mph}(2\text{hours}) = 14$ miles

At the same time Juan will have been walking for 4 hours so $3.5\text{mph}(4\text{ hours}) = 14$ miles.

They will meet after 14 miles.

20.

Speed of the current = x

Boat's speed in still water = 20 miles per hour

Upstream speed = $x - 20$

Downstream speed = $x + 20$

Upstream distance = 40 miles

Downstream distance = 60 miles

$$\frac{40}{x - 20} = \frac{60}{x + 20}$$

$$40(x + 20) = 60(x - 20)$$

$$40x + 800 = 60x - 1200$$

$$-20x = -2000$$

$$x = 100$$

The speed of the current is 100 mph.

21.

T = the time it takes Paul's mother to catch up with Paul.

Paul's Distance = $50(T + 2)$

Mom's distance = $70T$

$$70T = 50(T + 2)$$

$$70T = 50T + 100$$

$$20T = 100$$

$$T = 5$$

22.

Airplane speed = x

Wind speed = 30 miles per hour

Speed against the wind = $x - 30$

Speed with the wind = $x + 30$

Distance against the wind = 300 miles

Distance with the wind = 420 miles

$$\frac{300}{x - 30} = \frac{420}{x + 30}$$

$$300(x + 30) = 420(x - 30)$$

$$300x + 9000 = 420x - 12600$$

$$-120x = -21600$$

$$x = 180$$

The speed of the airplane with no wind is 180 mph.

23.

x

$x - 5$

$$\frac{420}{x-5} = \frac{420}{x} + 25$$

$$x(x-5) \cdot \frac{420}{x-5} = x(x-5) \cdot \frac{420}{x} + x(x-5) \cdot 25$$

$$420x = 420(x-5) + 25[x(x-5)]$$

$$420x = 420x - 2100 + 25(x^2 - 5x)$$

$$420x = 420x - 2100 + 25x^2 - 125x$$

$$0 = 25x^2 - 125x - 2100$$

$$0 = 25(x^2 - 5x - 84)$$

$$0 = 25(x-12)(x+7)$$

$$x-12=0$$

$$x=12$$

$$x+7=0$$

$$x=-7$$

The original group had 12 people in it.

24.

x

$x + 30$

$$\frac{2250}{x+30} = \frac{2250}{x} - 20$$

$$x(x+30) \cdot \frac{2250}{x+30} = x(x+30) \cdot \frac{2250}{x} - x(x+30) \cdot 20$$

$$2250x = 2250(x+30) - 20[x(x+30)]$$

$$2250x = 2250x + 67500 - 20(x^2 + 30x)$$

$$2250x = 2250x + 67500 - 20x^2 - 600x$$

$$0 = -20x^2 - 600x + 67500$$

$$0 = -20(x^2 + 30x - 3375)$$

$$0 = -20(x-45)(x+75)$$

$$x + 75 = 0$$

$$x = -75$$

$$x - 45 = 0$$

$$x = 45$$

The organization has 45 members.

Mixed Review

25.

$$-2 \frac{9}{10} \div -\frac{15}{8} = -\frac{29}{10} \times -\frac{8}{15} = \frac{232}{150} = \frac{116}{75} = 1 \frac{41}{75}$$

26.

$$-1.5(-3\frac{4}{5} + g) = \frac{201}{20}$$

$$-1.5(-3.8 + g) = 10.05$$

$$5.7 - 1.5g = 10.05$$

$$-1.5g = 4.35$$

$$g = -2.9$$

27.

$$6x^2 + 3x + 4 = 0$$

$$b^2 - 4ac = 3^2 - 4(6)(4) = 9 - 96 = -87$$

There are no roots.

28.

$$\frac{6b}{2b+2} + 3$$

$$\frac{6b}{2(b+1)} + 3$$

$$\frac{3b}{(b+1)} + 3$$

$$\frac{3b}{(b+1)} + 3 \cdot \frac{b+1}{b+1}$$

$$\frac{3b}{b+1} + \frac{3b+3}{b+1} = \frac{3b+3b+3}{b+1} = \frac{6b+3}{b+1} = \frac{3(2b+1)}{b+1}$$

29.

$$\frac{8}{2x-4} - \frac{5x}{x-5}$$

$$\frac{8}{2x-4} \cdot \frac{x-5}{x-5} - \frac{5x}{x-5} \cdot \frac{2x-4}{2x-4}$$

$$\frac{8(x-5)}{(2x-4)(x-5)} - \frac{5x(2x-4)}{(2x-4)(x-5)}$$

$$\frac{8x-40}{(2x-4)(x-5)} - \frac{10x^2-20x}{(2x-4)(x-5)}$$

$$\frac{8x-40-10x^2+20x}{(2x-4)(x-5)}$$

$$\frac{-10x^2+28x-40}{(2x-4)(x-5)}$$

30.

$$(7x^2 + 16x - 10) \div (x + 3)$$

$$\begin{array}{r} \overline{7x-5} \\ x+3 \overline{)7x^2+16x-10} \\ \underline{-7x^2-21x} \\ 0-5x-10 \\ \underline{0+5x+15} \\ 0+0+5 \end{array}$$

$$7x - 5(r5)$$

31.

$$(n-1) * (3n+2)(n-4)$$

$$(n-1) * (3n^2 - 10n - 8)$$

$$3n^3 - 10n^2 - 8n - 3n^2 - 10n - 8$$

$$3n^3 - 13n^2 - 18n - 8$$

Lesson 12.8

Surveys and Samples

1. The two most common types of sampling methods are random and stratified.

Random sampling is when everyone in the population has a equal chance of being chosen.

Stratified sampling is actively ensuring that people from different groups are in the sample.

-If you needed to survey a city about a new road project you would likely choose random sampling as it would be almost impossible to break an entire city into strata that would accurately represent the citizens of the city, all of whom would be affected by a road project.

2. A biased survey is when one or more subgroups of the population are either over represented or under represented in the sample. Bias can be eliminated by not cherry picking, by eliminating the non-response bias, and by not using a self selected sample. Also, it is important to carefully word questions so that they do not create bias.

3. Surveys are conducted by face to face interviews or self administered surveys.

Face to Face interviews have a high response rate, but are very time consuming. (any accurate answers from the list given in the lesson is acceptable)

Self administered surveys may get more honest results due to anonymity, but have lower response rates. (any accurate answers from the list given in the lesson is acceptable)

Surveys can also be conducted by phone. (other accurate answers would be acceptable)

4. Some keys to recognizing biased questions are finding polarizing language that assume emotion, finding a reference to an authority or apparent authority, finding phrasing that suggests the person asking the question already knows the answer, or finding ambiguous phrasing that often includes double negatives.

Answers to the second part will vary some may include: refusing to answer the question, pointing out the bias, etc

5. The most reliable sample would be choosing a stratified sample that includes equal numbers of boys and girls and equal numbers of students from each grade level and/or class.

6.

(a) not a good sample because you can't compare the choices of the wealthy with the choices of others.

(b) a biased sample because pedestrians will naturally want a crossing, your sample would also have to include the others affected by this like drivers and local businesses.

(c) this sample is pretty good, as long as it has a large enough sample that takes into account more than gender (age, occupation, geography, family status,etc) A random sample might be more effective

(c)

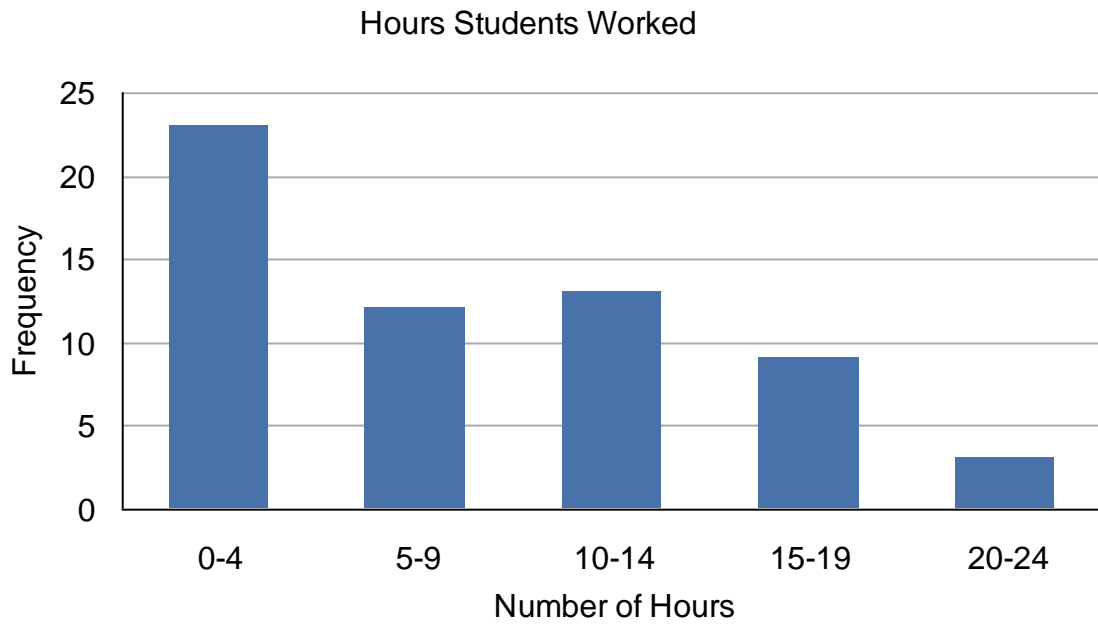

(d)

0,0,0,0,0,0,0,0,0,0,
0,0,0,0,0,0,0,0,0,0,
2,4,4,5,5,5,5,5,6,6,
7,7,8,8,8,10,10,10,10,10,
10,10,10,11,12,12,12,12,12,15,
15,15,15,15,16,18,18,20,20,22

Minimum = 0

Q_1 = 0

Median = 6.5

Q_3 = 12

Maximum = 22

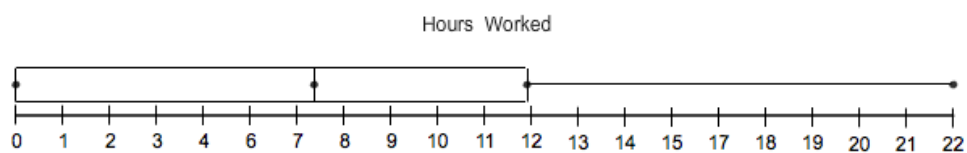

9. (Answers will vary, below are some possibilities)

- 1- The greatest number of students enjoy playing baseball.
- 2- The least number of students enjoy fencing.
- 3- A little more than half the students enjoy either baseball or soccer.
- 4- A little more than a quarter of the students enjoy either basketball or football.
- 5- A great majority of the students prefer team to individual sports.

10.

1.

Sports Students Watch on TV

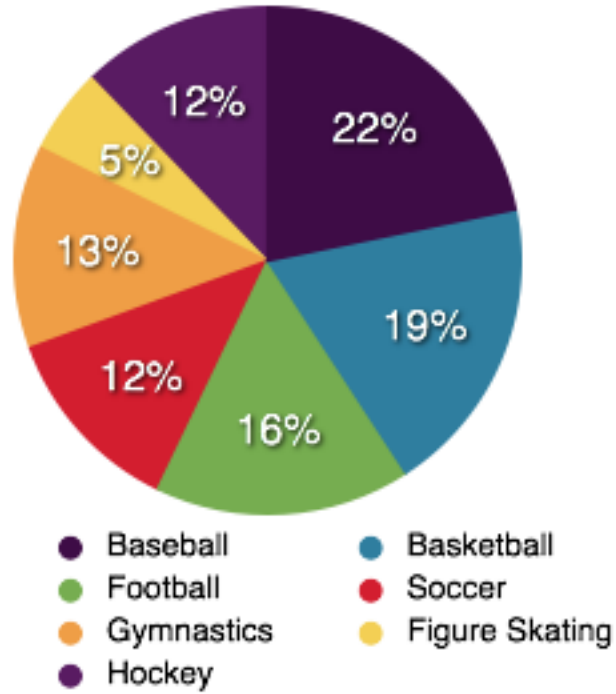

2.

Sports Students Watch on TV

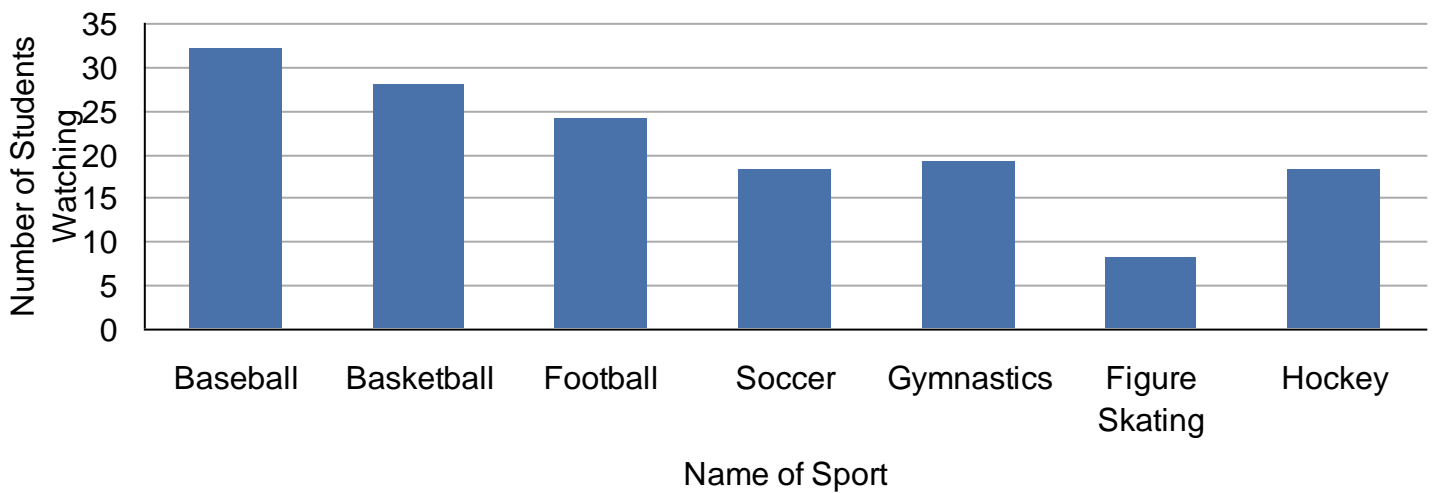

11.

1.

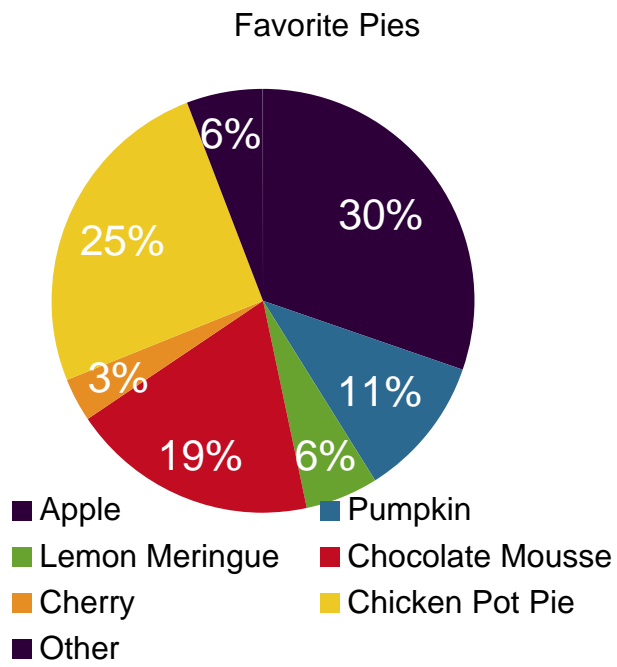

2.

Favorite Pies in Samuel's Town

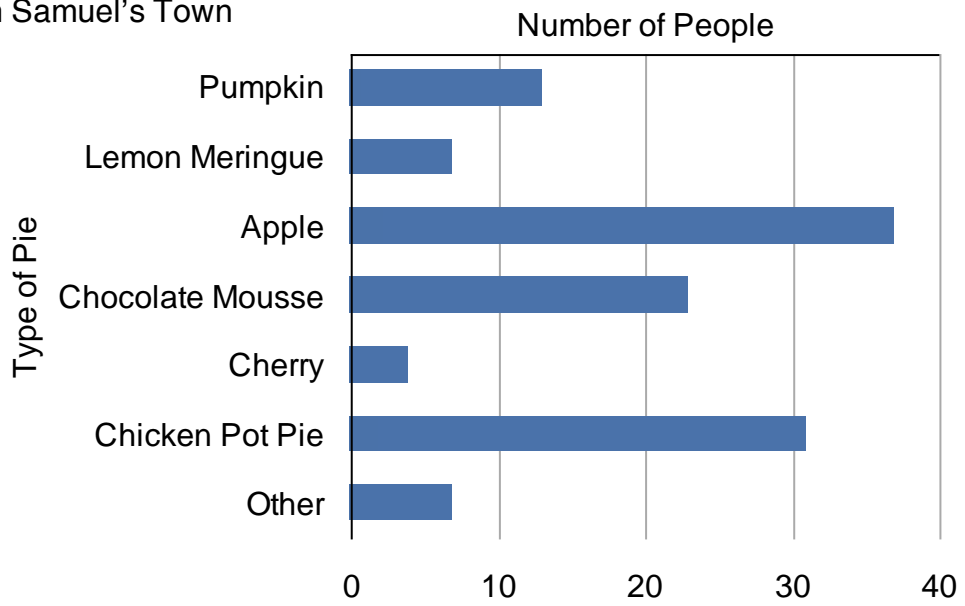

12.

1.

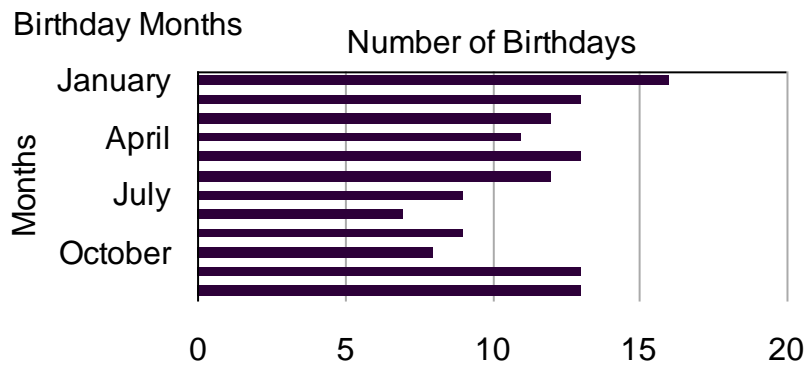

2.

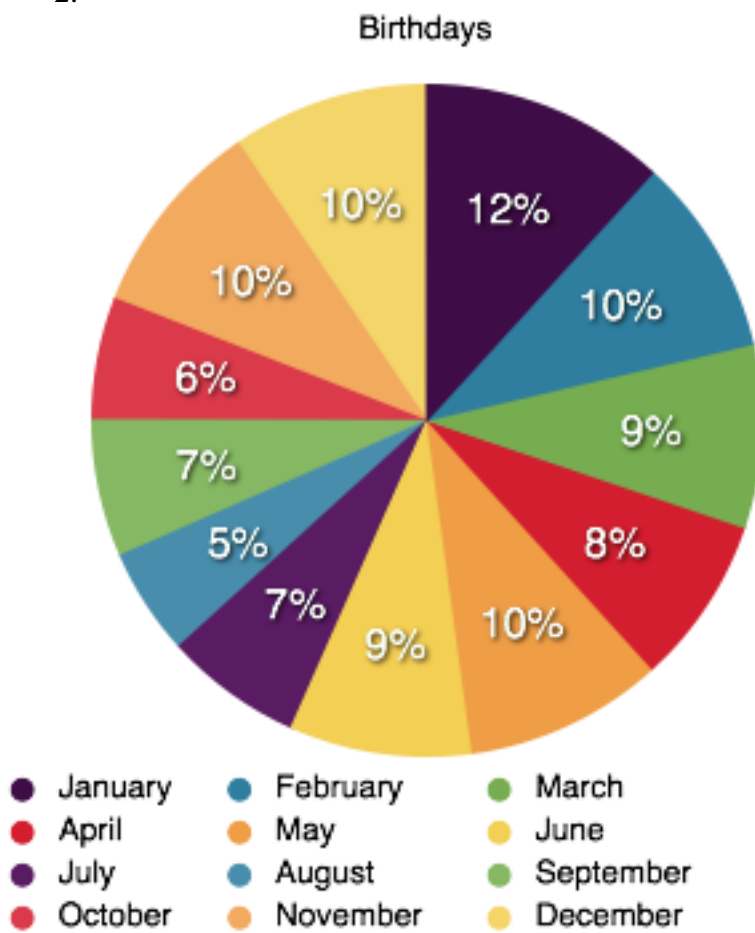

13.

1.

Voting Poll

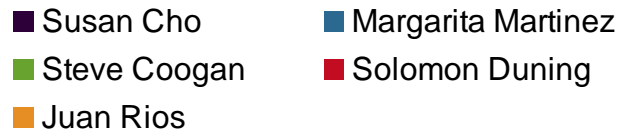
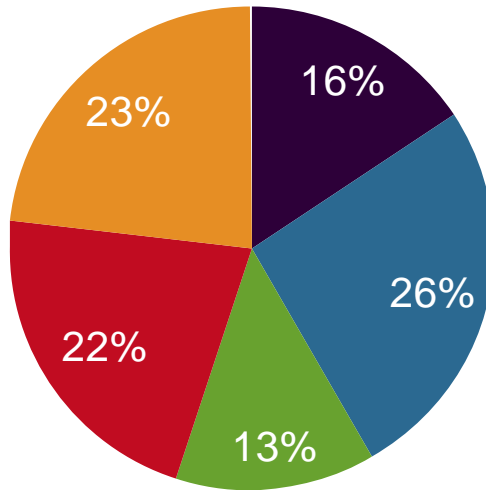

2.

Voting Poll Results Number of Voters

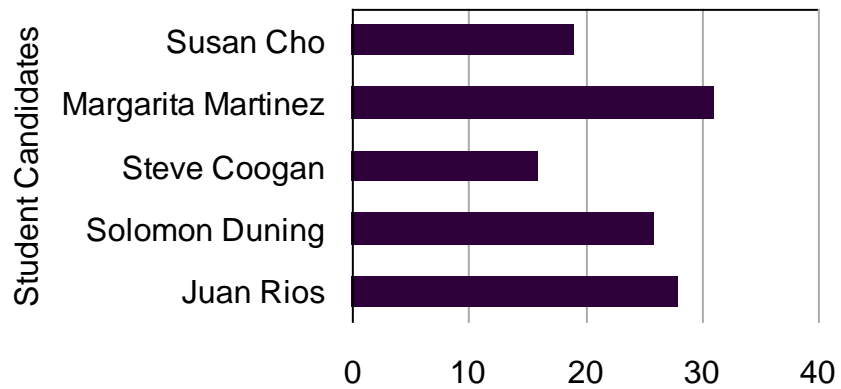

14.

1.

Hours of TV Watched	
Stem	Leaf
0	0,0,5,6,6,6,8,8,8,8,9,9
1	0,0,0,0,0,0,0,0,0,0,0,2,2,2,2,2,2,2,2,2,2,4,5,5,5,5,5,5,6,6,6,8,8,8,8
2	0,0,0,0,0,0,0,2,2,2,2,4,4,4,4,4,4,5,5,5,6,8,8
3	0,0,2,2,2,2,4,8

2.

Hours of TV	Frequency
0-9	12
10-19	37
20-29	23
30-39	8

3.

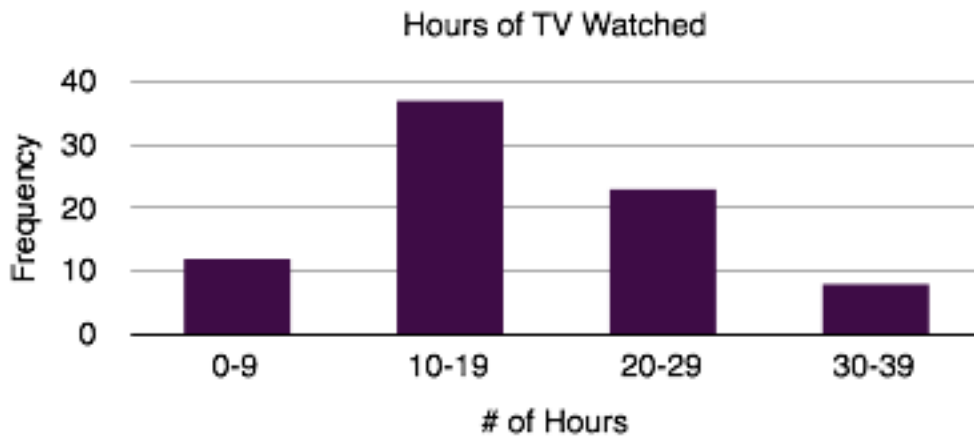

4.
 0,0,5,6,6,6,8,8,8,8,
 9,9,10,10,10,10,10,10,10,
 10,10,10,12,12,12,12,12,12,
 12,12,12,12,14,15,15,15,15,
 15,15,16,16,16,18,18,18,18,20,
 20,20,20,20,20,20,22,22,22,22,
 24,24,24,24,24,24,25,25,25,26,
 28,28,30,30,32,32,32,32,34,38

Minimum = 0

$Q_1 = 10$

Median = 15

$Q_3 = 23$

Maximum = 38

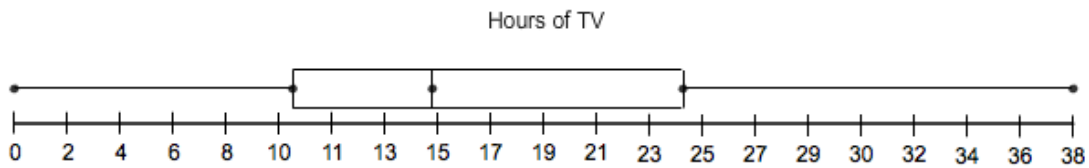

15. Answers will vary

16. Answers will vary

17. Answers will vary

18.

(a) Yes biased.

(b) Yes biased.

19. Answers will vary.

Mixed Review

20.

$$m = \frac{y_2 - y_1}{x_2 - x_1}$$

$$m = \frac{1 - (-6)}{8 - 4} = \frac{1 + 6}{8 - 4} = \frac{7}{4} = 1\frac{3}{4}$$

$$y - y_1 = m(x - x_1)$$

$$y - 1 = \frac{7}{4}(x - 8)$$

$$y - y_1 = m(x - x_1)$$

$$y - 0 = -\frac{4}{7}(x - 0)$$

$$(a) \quad y = -\frac{4}{7}x$$

$$y - y_1 = m(x - x_1)$$

$$y - 0 = \frac{7}{4}(x - 4)$$

$$y = \frac{7}{4}(x - 4)$$

$$(b) \quad y = \frac{7}{4}x - 7$$

21. $\sqrt[3]{64} = 4$

It is a real number, a rational number, an integer, a whole number, and a counting number.

22.

First Trip:

Speed = time/ distance

distance =22 miles

time= 45 minutes

Speed = $45/22 = 2.0454$ mph

Second Trip

Time= speed X distance

distance = 22 miles

time= 70 minutes

speed = wind minus the ferry= $w - 2.0454$

$70 = 22(w - 2.0454)$

$70 = 22w - 45$

$115 = 22w$

$w = 5.2272$

The ferry speed is approximately 2.0454 mph and the wind speed is approximately 5.2272 mph.

23.

$$\frac{6a}{a-1} = \frac{7}{a+7}$$

$$6a(a+7) = 7(a-1)$$

$$6a^2 + 42a = 7a - 7$$

$$6a^2 + 35a + 7 = 0$$

$$x = \frac{-b \pm \sqrt{b^2 - 4ac}}{2a}$$

$$x = \frac{-35 \pm \sqrt{35^2 - 4(6)(7)}}{2(6)}$$

$$x = \frac{-35 \pm \sqrt{1225 - 168}}{12}$$

$$x = \frac{-35 \pm \sqrt{1057}}{12}$$

$$x = \frac{-35 + \sqrt{1057}}{12} \approx \frac{-35 + 32.5115}{12} \approx \frac{-2.4885}{12} \approx -0.2074$$

$$x = \frac{-35 - \sqrt{1057}}{12} \approx \frac{-35 - 32.5115}{12} \approx \frac{-67.5115}{12} \approx -5.6259$$

24.

$$\frac{7}{18x^2} \cdot \frac{9x}{14} = \frac{1}{2x} \cdot \frac{1}{2} = \frac{1}{4x}$$

25.

$$\frac{2w^2 - 9w + 18}{w - 2}$$

$$\begin{array}{r} 2w - 5 \\ w - 2 \overline{) 2w^2 - 9w + 18} \\ \underline{-2w^2 + 4w} \\ 0 - 5w + 18 \\ \underline{0 + 5w - 10} \\ 0 + 0 + 8 \end{array}$$

$$2w - 5(r8)$$

26.

(a) It is a linear function. This situation can be written as $h=16s$ which is a line.

$$h = 16s$$

$$16(4) = 64$$

(b) $68.5 - 64 = 4.5$ The ballon started at 4.5 meters high.

Lesson 12.9

Chapter 12 Review

1. Inverse variation is when the relationship between two variables is such that they change in opposite directions. When one variable goes up, the other goes down and when one variable goes down, the other goes up.
2. Asymptotes are the excluded values of an inverse variation equation. The graph of such an equation will approach the value of the asymptote but never touch or cross it.
3. A Hyperbola is the form the graph of an inverse function takes. It has branches in two quadrants and is contained by vertical and horizontal asymptotes.
4. Points of discontinuity (or excluded values) are the values for which the denominator of the rational function is zero. These create the asymptotes.
5. The Least Common Multiple is the smallest number that all of a set of numbers can divide equally into. It is used to create lowest common denominators.
6. Random sampling is when subjects for a survey are chosen at random with no consideration of their background or characteristics. In a random sample everyone in the population has an equal chance of being chosen.
7. Stratified sampling is when the surveyor divides the population by characteristic or strata and chooses participants by ensuring that each strata is equally represented.
8. Biased is when a survey has one or more subgroups that are either over represented or under represented.
9. Cherry Picking is when you chose your sample from a group that is more likely to answer the way you want. Instead of random or carefully stratified samples, you choose a sample from the group that best meets your needs and will likely provide the results you desire.
10. If $k < 0$ then the branches of the hyperbola will be in quadrants II and IV.
11. inverse variation
12. direct variation
13. inverse variation
14. no relationship

15.

$$y = \frac{k}{x}$$

$$\frac{2}{15} = \frac{k}{5}$$

$$10 = 15k$$

$$k = \frac{10}{15} = \frac{2}{3}$$

$$y = \frac{\frac{2}{3}}{-\frac{1}{2}} = \frac{2}{3} \div -\frac{1}{2} = \frac{2}{3} * -\frac{2}{1} = -\frac{4}{3}$$

16.

$$y = \frac{k}{\sqrt{x}}$$

$$0.5625 = \frac{k}{\sqrt{16}}$$

$$0.5625 = \frac{k}{\pm 4}$$

$$k = \pm 2.25$$

$$y = \frac{\pm 2.25}{\frac{1}{8}} = \pm \frac{9}{4} \div \frac{1}{8} = \pm \frac{9}{4} * \frac{8}{1} = \pm 18$$

17.

Days to build the house = d

of volunteers = v

constant of variation = k

$$d = \frac{k}{v}$$

$$8 = \frac{k}{20}$$

$$k = 160$$

$$d = \frac{160}{16} = 10$$

18.

distance from seesaw = d

weight in kg = w

k = constant of variation

$$\text{Fulcrum} \rightarrow d = \frac{k}{w}$$

$$1.8 \text{ meters} = \frac{k}{20.43 \text{ kg}}$$

$$k = 36.774$$

$$d = \frac{36.774}{36.32 \text{ kg}} = 1.0125 \text{ meters}$$

19. $y = \frac{4}{x}$

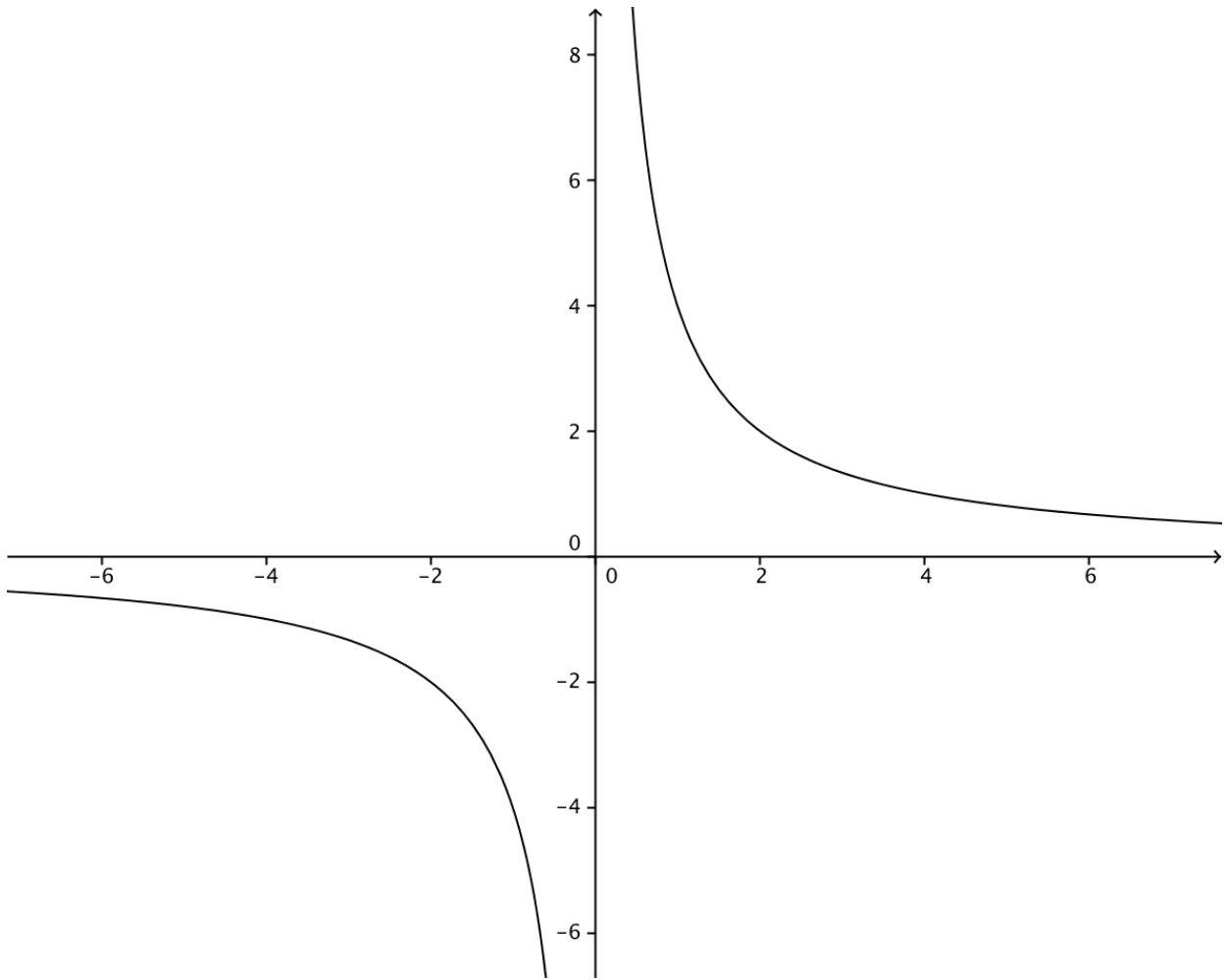

Domain: $x \neq 0$

Range: $y \neq 0$

Vertical asymptote: $x=0$

Horizontal asymptote: $y=0$

20. $f(x) = \frac{2}{4-x}$

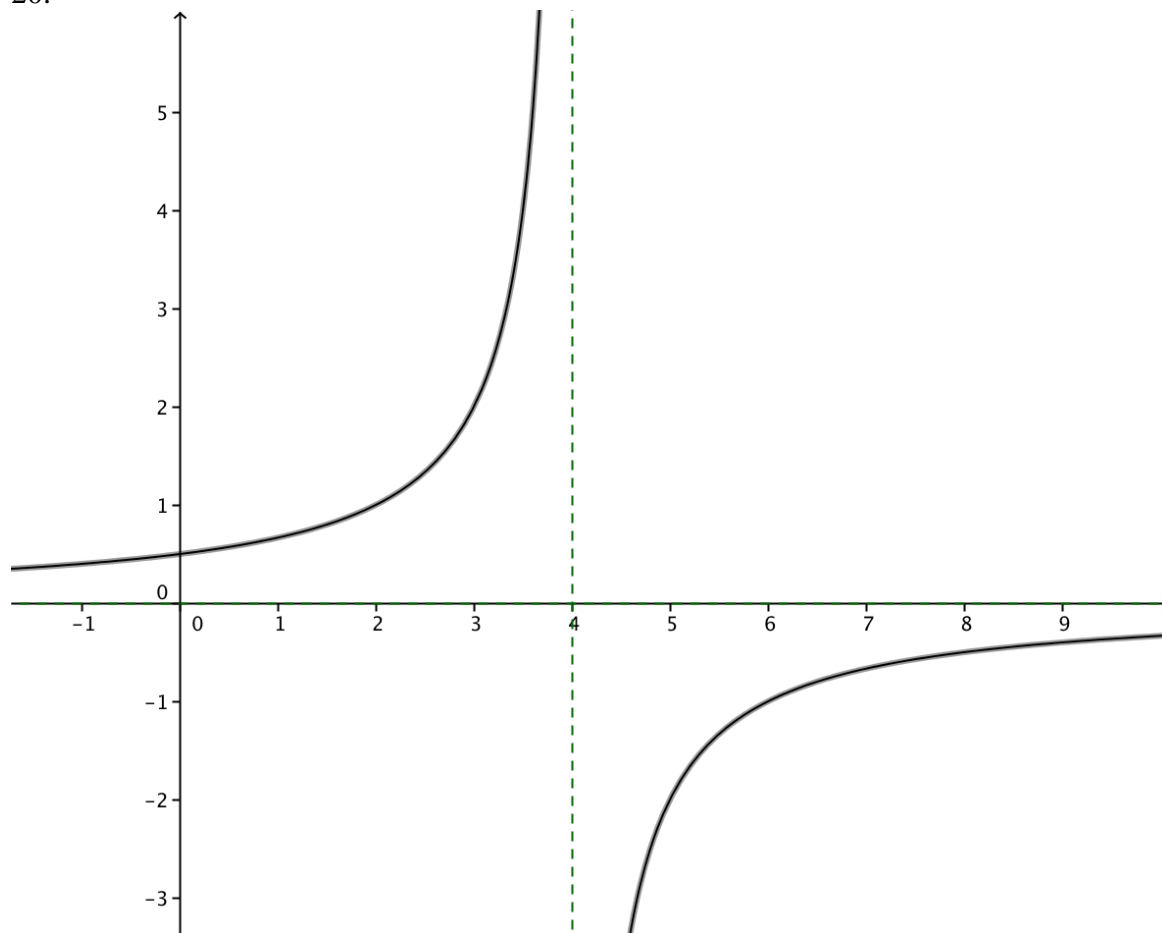

Domain: $x \neq 4$

Range: $y \neq 0$

Vertical Asymptote: $x=4$

Horizontal Asymptote: $y=0$

21. $g(x) = \frac{-1}{x+1}$

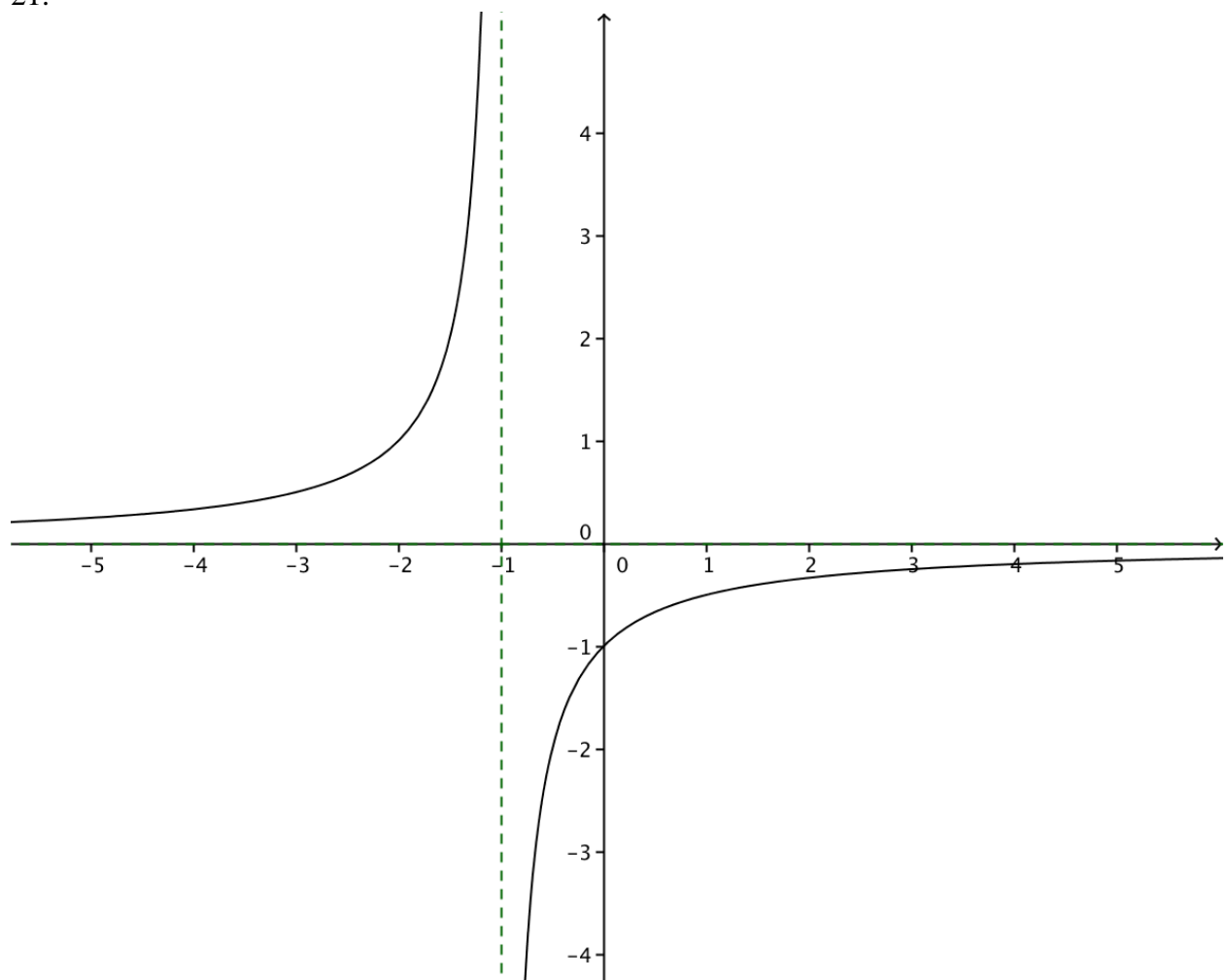

Domain: $x \neq -1$

Range: $y \neq 0$

Vertical asymptote: $x = -1$

Horizontal asymptote: $y = 0$

22. $y = \frac{6}{3x+1} - 2$

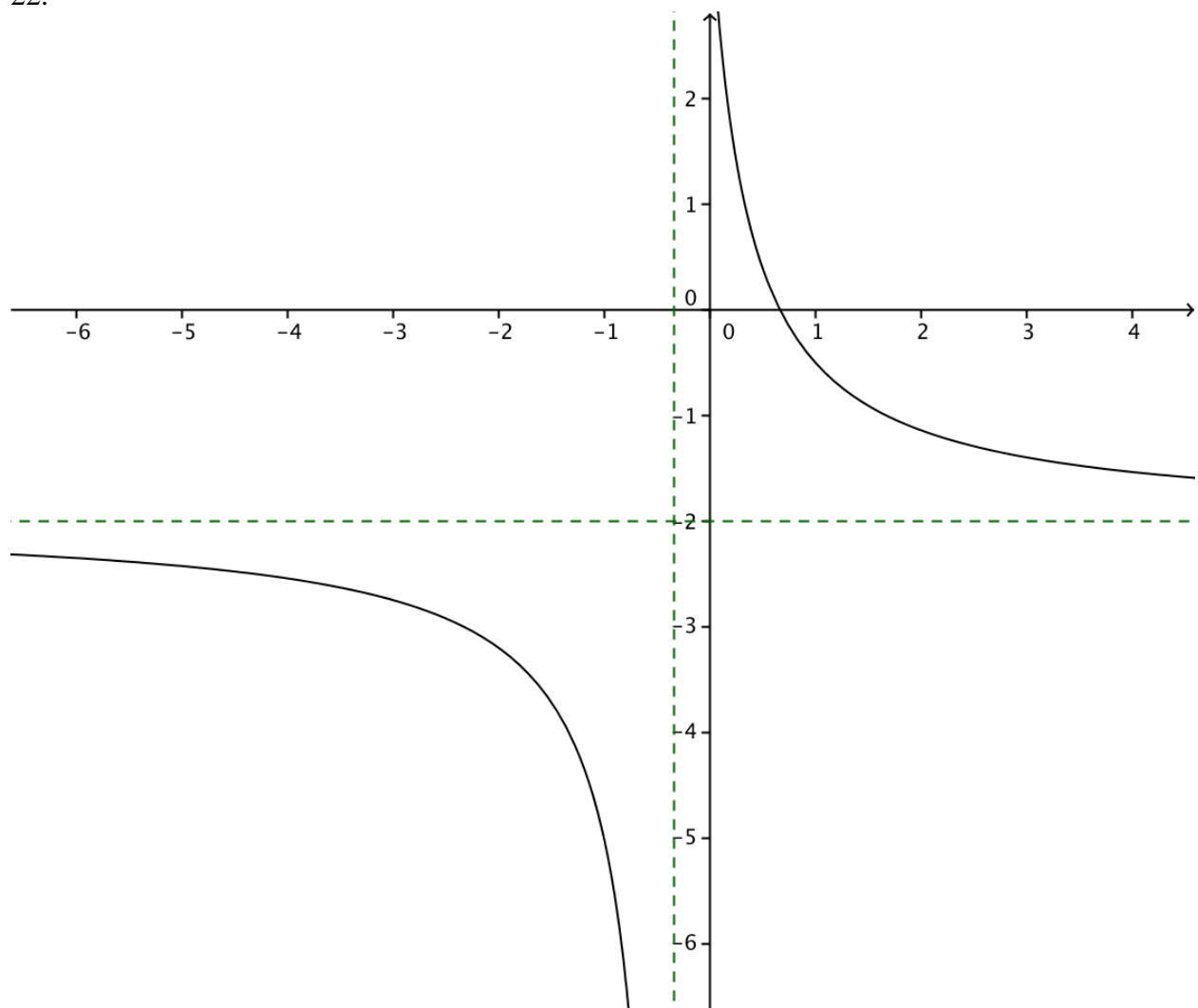

Domain: $x \neq -0.33$

Range: $y \neq -2$

Vertical asymptote: $x = -0.33$

Horizontal Asymptote: $y = -2$

23. $f(x) = \frac{3}{x} - 5$

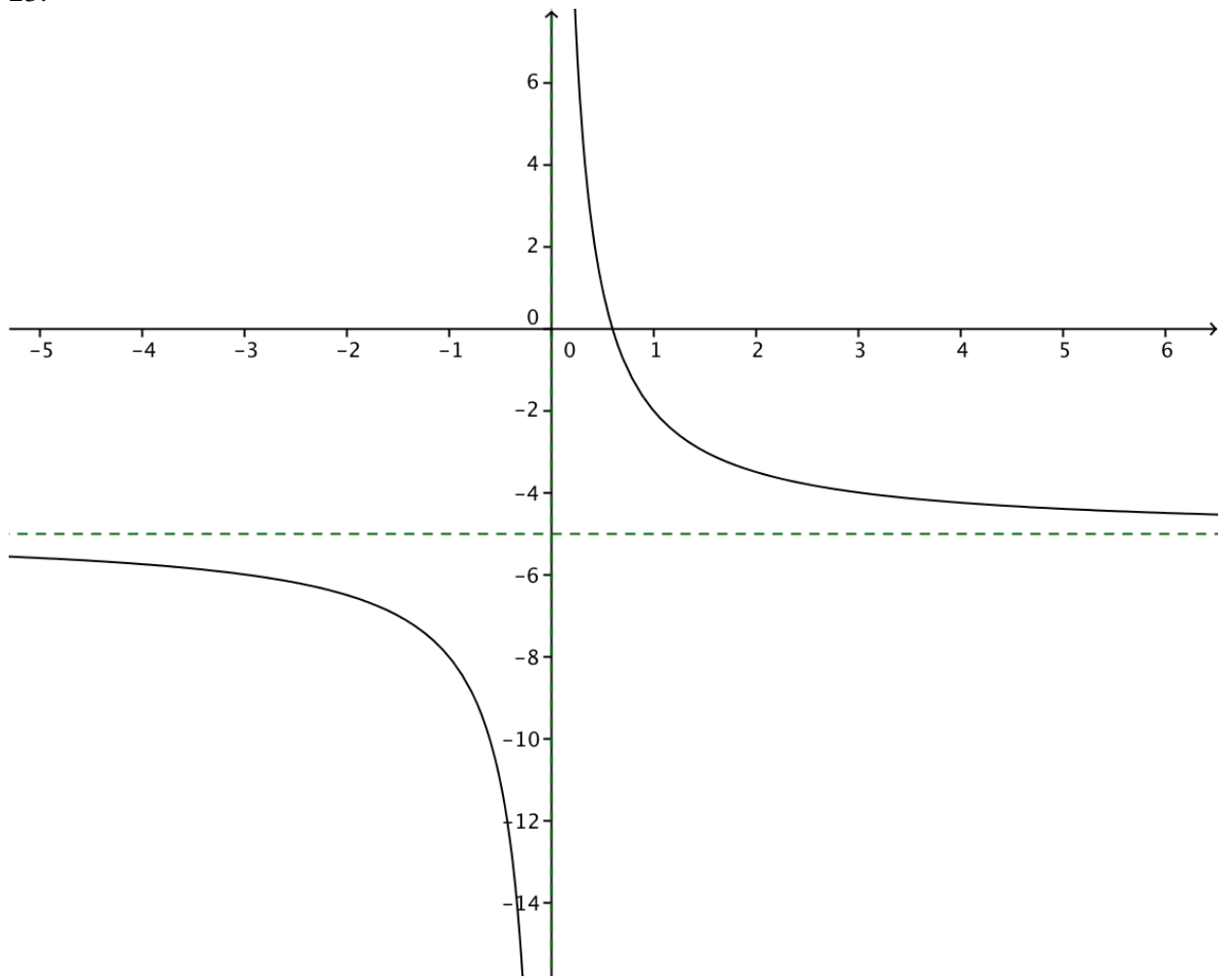

Domain: $x \neq 0$

Range: $y \neq -5$

Vertical Asymptote: $x=0$

Horizontal Asymptote: $y=-5$

24.

$$\frac{5a}{6} - \frac{5b}{4b}$$

$$\frac{5a(2b)}{12b} - \frac{5b(3)}{12b}$$

$$\frac{10ab}{12b} - \frac{15b}{12b} = \frac{10ab - 15b}{12b} = \frac{5b(2a - 3)}{12b} = \frac{5(2a - 3)}{12}$$

25.

$$\begin{aligned}\frac{4}{3m} + \frac{4m}{5} \\ \frac{4(5)}{15m} + \frac{4m(3m)}{15m} \\ \frac{20}{15m} + \frac{12m^2}{15m} = \frac{20+12m^2}{15m}\end{aligned}$$

26.

$$\begin{aligned}\frac{3x}{2xy} + \frac{4}{3} \\ \frac{3x(3)}{6xy} + \frac{4(2xy)}{6xy} \\ \frac{9x}{6xy} + \frac{8xy}{6xy} = \frac{9x+8xy}{6xy} = \frac{x(9+8y)}{6xy} = \frac{9+8y}{6y}\end{aligned}$$

27.

$$\begin{aligned}\frac{2}{5n-2} + \frac{2n}{2} \\ \frac{2(2)}{2(5n-2)} + \frac{2n(5n-2)}{2(5n-2)} \\ \frac{4}{2(5n-2)} + \frac{10n^2-4n}{2(5n-2)} \\ \frac{10n^2-4n+4}{2(5n-2)} = \frac{2(5n^2-2n+2)}{2(5n-2)} = \frac{(5n^2-2n+2)}{(5n-2)}\end{aligned}$$

28.

$$\frac{2x+1}{3x+9} - \frac{x+5}{3x+9} = \frac{2x+1-x-5}{3x-9} = \frac{x-4}{3x-9}$$

29.

$$\frac{5m+n}{30n^4} - \frac{4m+n}{30n^4} = \frac{5m+n-4m-n}{30n^4} = \frac{m}{30n^4}$$

30.

$$\frac{r-6}{4r^2-12r+8} - \frac{r+6}{4r^2-12r+8} = \frac{r-6-r-6}{4r^2-12r+8} = \frac{-12}{4(r^2-3r+2)} = \frac{-3}{r^2-3r+2}$$

31.

$$\frac{2}{16x^3y^2} + \frac{x-2y}{16x^3y^2} = \frac{2+x-2y}{16x^3y^2}$$

32.

$$\begin{aligned} & \frac{n-6}{n+2} + \frac{2n}{5} \\ & \frac{5(n-6)}{5(n-2)} + \frac{2n(n-2)}{5(n-2)} \\ & \frac{5n-30}{5(n-2)} + \frac{2n^2-4n}{5(n-2)} \\ & \frac{5n-30+2n^2-4n}{5(n-2)} = \frac{2n^2+n-30}{5(n-2)} \end{aligned}$$

33.

$$\begin{aligned} & \frac{8}{4} - \frac{x+5}{x+8} \\ & 2 - \frac{x+5}{x+8} \\ & \frac{2(x+8)}{x+8} - \frac{x+5}{x+8} \\ & \frac{2x+16-x-5}{x+8} = \frac{x+11}{x+8} \end{aligned}$$

34.

$$\begin{aligned} & \frac{3x}{2(x+1)} + \frac{6}{7x-6} \\ & \frac{3x(7x-6)}{(2x+2)(7x-6)} + \frac{6(2x+2)}{(2x+2)(7x-6)} \\ & \frac{21x^2-18x}{(2x+2)(7x-6)} + \frac{12x+12}{(2x+2)(7x-6)} \\ & \frac{21x^2-18x+12x+12}{(2x+2)(7x-6)} = \frac{21x^2-6x+12}{(2x+2)(7x-6)} = \frac{3(7x^2-2x+4)}{(2x+2)(7x-6)} \end{aligned}$$

35.

$$\frac{11}{8} \cdot \frac{20x^2}{2} = \frac{55x^2}{4}$$

36.

$$\frac{17r}{16} \cdot \frac{7r^4}{16} = \frac{119r^5}{256}$$

37.

$$\frac{15}{18} \cdot \frac{14}{17t} = \frac{35}{51t}$$

38.

$$\frac{2(b-11)}{14b} \cdot \frac{b+5}{(b+5)(b-11)} = \frac{1}{7b}$$

39.

$$\frac{17w^2}{w+4} \cdot \frac{18(w+4)}{17w^2(w-9)} = \frac{18}{w-9}$$

40.

$$\begin{aligned} & \frac{10s^3-30s^2}{30s^2-10s^3} \cdot \frac{s-3}{8} \\ & \frac{10s^2(s-3)}{10s^2(3-s)} \cdot \frac{s-3}{8} = \frac{s^2-6s+9}{24-8s} \end{aligned}$$

41.

$$\frac{1}{f-5} \div \frac{f+3}{f^2+6f+9}$$

$$\frac{1}{f-5} \div \frac{f+3}{(f+3)(f+3)} = \frac{1}{f-5} \div \frac{1}{f+3} = \frac{1}{f-5} * \frac{f+3}{1} = \frac{f+3}{f-5}$$

42.

$$\frac{(a+8)(a+3)}{4(a+3)} \div \frac{10a^2(a+10)}{4}$$

$$\frac{a+8}{4} * \frac{4}{10a^2(a+10)} = \frac{a+8}{10a^2(a+10)}$$

43.

$$\frac{1}{(h-10)(h+7)} \div \frac{(h-4)}{4h(h-10)} = \frac{1}{(h-10)(h+7)} * \frac{4h(h-10)}{(h-4)} = \frac{4h}{(h+7)(h-4)}$$

44.

$$\frac{2(5x-8)}{4x^2(8-5x)} \div \frac{6}{4x^2}$$

$$\frac{5x-8}{2x^2(8-5x)} \div \frac{3}{2x^2}$$

$$\frac{5x-8}{2x^2(8-5x)} * \frac{2x^2}{3} = \frac{5x-8}{3(8-5x)}$$

45.

$$\frac{2(q-7)}{40q(q+1)} \div \frac{1}{40q(q+1)}$$

$$\frac{2(q-7)}{40q(q+1)} * \frac{40q(q+1)}{1} = 2q-14$$

46.

$$\frac{3}{3x^2} = \frac{1}{x} + \frac{1}{3x^2}$$

$$3x^2 \cdot \frac{3}{3x^2} = 3x^2 \cdot \frac{1}{x} + 3x^2 \cdot \frac{1}{3x^2}$$

$$3 = 3x + 1$$

$$2 = 3x$$

$$x = \frac{2}{3}$$

47.

$$\frac{2}{5x^2} = -\frac{12}{x-3}$$

$$-12(5x^2) = 2(x-3)$$

$$-60x^2 = 2x - 6$$

$$0 = 60x^2 + 2x - 6$$

$$0 = 2(30x^2 + x - 3)$$

$$x = \frac{-b \pm \sqrt{b^2 - 4ac}}{2a}$$

$$x = \frac{-1 \pm \sqrt{1^2 - 4(30)(-3)}}{2(30)}$$

$$x = \frac{-1 \pm \sqrt{1 + 360}}{60}$$

$$x = \frac{-1 \pm \sqrt{361}}{60}$$

$$x = \frac{-1 + \sqrt{361}}{60} = \frac{-1 + 19}{60} = \frac{18}{60} = 0.3$$

$$x = \frac{-1 - \sqrt{361}}{60} = \frac{-1 - 19}{60} = \frac{-20}{60} = -0.3333$$

48.

$$\frac{7x}{x-6} = \frac{3}{4x+16}$$

$$7x(4x+16) = 3(x-6)$$

$$28x^2 + 112x = 3x - 18$$

$$28x^2 + 109x + 18 = 0$$

$$x = \frac{-b \pm \sqrt{b^2 - 4ac}}{2a}$$

$$x = \frac{-109 \pm \sqrt{109^2 - 4(28)(18)}}{2(28)}$$

$$x = \frac{-109 \pm \sqrt{11881 - 2016}}{56}$$

$$x = \frac{-109 \pm \sqrt{9865}}{56}$$

$$x = \frac{-109 + \sqrt{9865}}{56} \approx \frac{-109 + 99.3227}{56} \approx \frac{-9.6773}{56} \approx -0.1728$$

$$x = \frac{-109 - \sqrt{9865}}{56} \approx \frac{-109 - 99.3227}{56} \approx \frac{-208.3227}{56} \approx -3.72$$

49.

$$\frac{4}{c-2} = \frac{3}{c+4}$$

$$4(c+4) = 3(c-2)$$

$$4c + 16 = 3c - 6$$

$$c = -22$$

50.

$$\frac{d-4}{4d^2} = \frac{1}{4d^2} + \frac{2}{4d}$$

$$4d^2 \cdot \frac{d-4}{4d^2} = 4d^2 \cdot \frac{1}{4d^2} + 4d^2 \cdot \frac{2}{4d}$$

$$d-4 = 1+2d$$

$$-5 = d$$

$$d = -5$$

51.

$$\frac{1}{2} = \frac{2z-12}{z} - \frac{z+1}{4z}$$

$$\frac{1}{2} = \frac{4}{4} \cdot \frac{2z-12}{z} - \frac{z+1}{4z}$$

$$\frac{1}{2} = \frac{4(2z-12)}{4z} - \frac{z+1}{4z}$$

$$\frac{1}{2} = \frac{8z-48}{4z} - \frac{z+1}{4z}$$

$$\frac{1}{2} = \frac{8z-48-z-1}{4z}$$

$$\frac{1}{2} = \frac{7z-49}{4z}$$

$$4z = 2(7z-49)$$

$$4z = 14z - 98$$

$$98 = 10z$$

$$z = 9.8$$

52.

$$\frac{1}{n} = \frac{1}{n^2} + \frac{6}{n}$$

$$n^2 \cdot \frac{1}{n} = n^2 \cdot \frac{1}{n^2} + n^2 \cdot \frac{6}{n}$$

$$n = 1 + 6n$$

$$-1 = 5n$$

$$n = -\frac{1}{5} = -0.2$$

53.

$$\frac{1}{2a} = \frac{1}{2a^2} + \frac{1}{a}$$

$$2a^2 \cdot \frac{1}{2a} = 2a^2 \cdot \frac{1}{2a^2} + 2a^2 \cdot \frac{1}{a}$$

$$a = 1 + 2a$$

$$-a = 1$$

$$a = -1$$

54.

$$\frac{k+4}{k^2} = \frac{5k-30}{3k^2} + \frac{1}{3k^2}$$
$$3k^2 \cdot \frac{k+4}{k^2} = 3k^2 \cdot \frac{5k-30}{3k^2} + 3k^2 \cdot \frac{1}{3k^2}$$
$$3(k+4) = (5k-30)+1$$
$$3k+12 = 5k-29$$
$$12 = 2k-29$$
$$41 = 2k$$
$$k = 20.5$$

55.

Part of task completed = rate of work X time spent on task

Painter	Rate of Work (per hour)	Time Worked	Part of Task
Jayden	1/7	t	t/7
Andie	1/5	t	t/5

Part of task Jayden + Part of task Andie = 1 complete task

$$\frac{t}{7} + \frac{t}{5} = 1$$
$$\frac{5t}{35} + \frac{7t}{35} = 1$$
$$\frac{12t}{35} = 1$$
$$12t = 35$$
$$t = \frac{35}{12} \approx 2.917$$

It takes approximately 2.917 hours to paint a room if Jayden and Andie work together.

56.

Part of task completed = rate of work X time spent on task

Mower	Rate of Work (per hour)	Time Worked	Part of Task
Kiefer	1/4.5	t	t/4.5
Brad	1/2	t	t/2

Part of task Kiefer + Part of task Brad = 1 complete task

$$\frac{t}{4.5} + \frac{t}{2} = 1$$

$$\frac{2t}{9} + \frac{4.5t}{9} = 1$$

$$\frac{6.5t}{9} = 1$$

$$6.5t = 9$$

$$t \approx 1.3846$$

It takes approximately 1.3846 hours to mow the lawn if Kiefer and Brad work together.

57.

Melissa can mop the floor in 1.75 hours or 105 minutes.

Brad + Melissa can mop the floor in 50 minutes.

Part of task completed = rate of work X time spent on task

Mower	Rate of Work (per hour)	Time Worked	Part of Task
Melissa	1/105	50	50/105
Brad	1/x	50	50/x

Part of task Melissa + Part of task Brad = 1 complete task

$$\frac{50}{105} + \frac{50}{x} = 1$$

$$\frac{50x}{105x} + \frac{50(105)}{105x} = 1$$

$$\frac{50x + 5250}{105x} = 1$$

$$50x + 5250 = 105x$$

$$5250 = 55x$$

$$x = 95.4545$$

It would take Brad approximately 95.4545 minutes or 1.59 hours to mop the floor himself.

58.

Frankie can frame a room in 15 hours.

Frankie + Ricky can frame a room in 8 hours.

Part of task completed = rate of work X time spent on task

Framer	Rate of Work (per hour)	Time Worked	Part of Task
Frankie	1/15	8	8/15
Ricky	1/x	8	8/x

Part of task Frankie + Part of task Ricky = 1 complete task

$$\frac{8}{15} + \frac{8}{x} = 1$$

$$\frac{8x}{15x} + \frac{8(15)}{15x} = 1$$

$$\frac{8x + 120}{15x} = 1$$

$$8x + 120 = 15x$$

$$120 = 7x$$

$$x = 17.1429$$

It would take Ricky approximately 17.1429 hours to frame a room by himself.

59.

$$\frac{1}{R_t} = \frac{1}{R_1} + \frac{1}{R_2}$$

$$\frac{1}{16} = \frac{1}{50} + \frac{1}{R_2}$$

$$\frac{1}{16} - \frac{1}{50} = \frac{1}{R_2}$$

$$\frac{50}{800} - \frac{16}{800} = \frac{1}{R_2}$$

$$\frac{34}{800} = \frac{1}{R_2}$$

$$34R_2 = 800$$

$$R_2 \approx 23.5294\Omega$$

60.

$$\frac{1}{R_t} = \frac{1}{R_1} + \frac{1}{R_2}$$

$$\frac{1}{R_t} = \frac{1}{6} + \frac{1}{9}$$

$$\frac{1}{R_t} = \frac{3}{18} + \frac{2}{18}$$

$$\frac{1}{R_t} = \frac{5}{18}$$

$$18 = 5R_t$$

$$R_t = 3.6\Omega$$

61.

$$R_t = R_1 + R_2$$

$$300 = 200 + R_2$$

$$100 = R_2$$

$$R_2 = 100\Omega$$

62.

$$R_t = R_1 + R_2$$

$$R_t = 11 + 25$$

$$R_t = 36\Omega$$

63.

$$\frac{1}{R_t} = \frac{1}{R_1} + \frac{1}{R_2} + \frac{1}{R_3}$$

64. The bias occurs because when you only ask people already in the chip aisle, you know they already buy chips. If you want a truly unbiased sample you have to include people who don't always or normally buy chips.

65.

1. Determine the goal of your survey, What question do you want to answer?
2. Identify the sample population. Who will you interview?
3. Choose an interviewing method, face-to-face interview, phone interview or self-administered paper survey or internet survey.
4. Conduct the interview and collect the information.
5. Analyze the results by making graphs and drawing conclusions.

66. Answers will vary. (Should follow the steps from #65 and have pertinent questions.)

67. A stratified sample is a sample where the person conducting the survey divides the population into groups by a certain characteristic. These groups are called strata. The surveyor then chooses a sample in which each strata has the same number of people in the sample. Examples will vary.

Lesson 12.10
Chapter 12 Test

1. False: a horizontal asymptote DOES have the equation $y=c$, but it represents the vertical shift of the rational function NOT where the denominator of the rational function is equal to zero.

2. The potential bias is that by wearing SADD t-shirts they tell the respondents what they are against and likely bias the results. The respondents will be more likely to tell them what they want to hear. By not wearing the t-shirts and not telling the members of the sample what group they are from they will get more accurate results. Or they could use an anonymous self directed survey.

3. The four ways questions can be biased are:

-polarizing language that assume emotion

-a reference to an authority or apparent authority

-phrasing that suggests the person asking the question already knows the answer

-ambiguous phrasing that often includes double negatives

4. Box and whisker plots are very useful in showing data comparing two categories.

5. $f(x) = -\frac{4}{x}$

Domain: $x \neq 0$

Range: $y \neq 0$

Vertical Asymptote: $x=0$

Horizontal Asymptote: $y=0$

Branches are in quadrants II and IV

6.

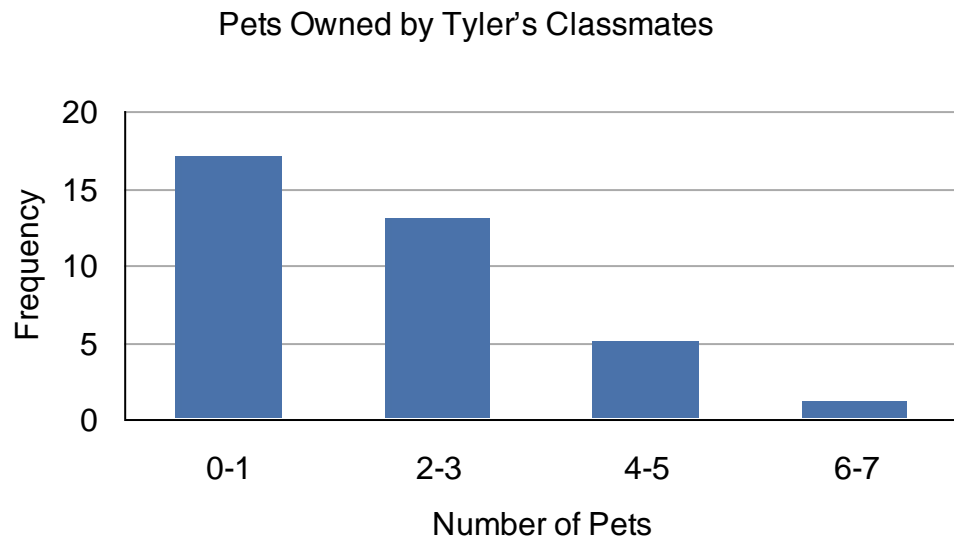

$$h = \frac{k}{r}$$

$$-2.25 = \frac{k}{0.125}$$

$$k = -0.28125$$

$$h = \frac{-0.28125}{12}$$

$$h = -0.0234375$$

7. Two types of visual displays that could be used with a frequency distribution are a histogram and a pie chart.

8.

1.

Number of Pets	Tally	Frequency
0-1	IIII-IIII-IIII-II	17
2-3	IIII-IIII-III	13
4-5	IIII-	5
6-7	I	1

2.

3.

0,0,0,0,0,0,0,1,1,1,

1,1,1,1,1,1,2,2,2,

2,2,2,2,3,3,3,3,3,3,

4,4,4,4,5,7

Minimum = 0

Q_1 = 1

Median = 2

Q_3 = 3

Maximum = 7

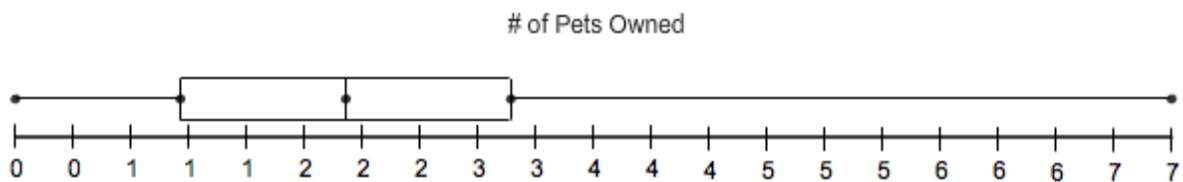

4.

5. Answers will vary.

9.

$$f(x) = -\frac{9}{x^2 - 16} + 4$$

Excluded Values: $x=4$, $x=-4$

Domain: $x \neq 4$, $x \neq -4$

Range: $y \neq 4$

Vertical Asymptotes: $x=4$, $x=-4$

Horizontal Asymptotes: $y=4$

10.

$$\frac{4}{21r^4} + \frac{4r+5t}{21r^4} = \frac{4+4r+5t}{21r^4}$$

11.

$$\frac{a-v}{12a^3} - \frac{a+5v}{12a^3} = \frac{a-v-a-5v}{12a^3} = \frac{-6v}{12a^3}$$

12.

$$\begin{aligned} & \frac{8}{g+8} + \frac{g-3}{g-5} \\ & \frac{8}{g+8} \cdot \frac{g-5}{g-5} + \frac{g-3}{g-5} \cdot \frac{g+8}{g+8} \\ & \frac{8(g-5)}{(g+8)(g-5)} + \frac{(g-3)(g+8)}{(g+8)(g-5)} \\ & \frac{8g-40}{(g+8)(g-5)} + \frac{g^2+5g-24}{(g+8)(g-5)} \\ & \frac{8g-40+g^2+5g-24}{(g+8)(g-5)} \\ & \frac{g^2+13g-64}{(g+8)(g-5)} \end{aligned}$$

13.

$$\begin{aligned} & \frac{4t}{5t-8} + \frac{24}{12} \\ & \frac{4t}{5t-8} + 2 \\ & \frac{4t}{5t-8} + \frac{5t-8}{5t-8} \cdot 2 \\ & \frac{4t}{5t-8} + \frac{10t-16}{5t-8} \\ & \frac{4t+10t-16}{5t-8} \\ & \frac{14t-16}{5t-8} \end{aligned}$$

14.

$$\frac{4}{5} \cdot \frac{80}{48m} = \frac{1}{1} \cdot \frac{16}{12m} = \frac{16}{12m} = \frac{4}{3m}$$

15.

$$\frac{1}{d-8} \div \frac{d+7}{2d+14} = \frac{1}{d-8} \div \frac{d+7}{2(d+7)} = \frac{1}{d-8} \div \frac{1}{2} = \frac{1}{d-8} * \frac{2}{1} = \frac{2}{d-8}$$

16.

$$\frac{1}{u-3} \div \frac{u-4}{2u-6} = \frac{1}{u-3} \div \frac{u-4}{2(u-3)} = \frac{1}{u-3} * \frac{2(u-3)}{u-4} = \frac{1}{1} * \frac{2}{u-4} = \frac{2}{u-4}$$

17.

$$\begin{aligned} & \frac{7w}{w-7} = \frac{7w}{w+5} \\ & 7w(w+5) = 7w(w-7) \\ & 7w^2 + 35w = 7w^2 - 49w \\ & 84w = 0 \\ & w = 0 \end{aligned}$$

18.

$$\frac{p-6}{3p^2-6p} = \frac{7}{3}$$

$$3(p-6) = 7(3p^2-6p)$$

$$3p-18 = 21p^2-42p$$

$$0 = 21p^2-45p+18$$

$$0 = 3(7p^2-15p+6)$$

$$x = \frac{-b \pm \sqrt{b^2-4ac}}{2a}$$

$$x = \frac{-(-15) \pm \sqrt{(-15)^2-4(7)(6)}}{2(7)}$$

$$x = \frac{15 \pm \sqrt{225-168}}{14}$$

$$x = \frac{15 \pm \sqrt{57}}{14}$$

$$x = \frac{15 + \sqrt{57}}{14} \approx 1.6107$$

$$x = \frac{15 - \sqrt{57}}{14} \approx 0.5322$$

19.

$$\frac{2}{x^2} = \frac{1}{2x^2} - \frac{x+1}{2x^2}$$

$$2x^2 \cdot \frac{2}{x^2} = 2x^2 \cdot \frac{1}{2x^2} - 2x^2 \cdot \frac{x+1}{2x^2}$$

$$2 \cdot 2 = 1 - x - 1$$

$$4 = -x$$

$$x = -4$$

20.

$$\frac{1}{2} - \frac{1}{4r} = \frac{3}{4}$$

$$4r \cdot \frac{1}{2} - 4r \cdot \frac{1}{4r} = 4r \cdot \frac{3}{4}$$

$$2r(1) - 1 = 3r$$

$$2r - 1 = 3r$$

$$-1 = r$$

$$r = -1$$

21.

$$\frac{y-5}{3y^2} = -\frac{1}{3y} + \frac{1}{y^2}$$

$$3y^2 \cdot \frac{y-5}{3y^2} = -\frac{1}{3y} \cdot 3y^2 + \frac{1}{y^2} \cdot 3y^2$$

$$y-5 = -y+3$$

$$2y = 8$$

$$y = 4$$

22.

Part of task completed= rate X time

Tiler	Rate of work (per hour)	Total time	Part of Task
Ashton	1/2 hrs=1/120min	25min	25/120
Matt	1/x	25min	25/x

Part of task Ashton + Part of task Matt= 1 completed task

$$\frac{25}{120} + \frac{25}{x} = 1$$

$$\frac{25x}{120x} + \frac{25(120)}{120x} = 1$$

$$\frac{25x + 3000}{120x} = 1$$

$$25x + 3000 = 120x$$

$$3000 = 95x$$

$$x \approx 32$$

It would take Matt approximately 32 minutes to tile the floor.

23.

Part of task completed= rate X time

Painter	Rate of work (per hour)	Total time	Part of Task
Bethany	1/12	t	t/12
Melissa	1/5	t	t/5

Part of task Bethany+ Part of task Melissa= 1 completed task

$$\frac{t}{12} + \frac{t}{5} = 1$$

$$\frac{5t}{60} + \frac{12t}{60} = 1$$

$$\frac{17t}{60} = 1$$

$$17t = 60$$

$$t \approx 3.5294$$

It would take approximately 3.5 hours to paint the deck if the two girls work together.

24.

$$\frac{1}{R_t} = \frac{1}{R_1} + \frac{1}{R_2}$$

$$\frac{1}{115} = \frac{1}{R_1} + \frac{1}{75}$$

$$\frac{1}{115} - \frac{1}{75} = \frac{1}{R_1}$$

$$\frac{15}{1725} - \frac{23}{1725} = \frac{1}{R_1}$$

$$\frac{-8}{1725} = \frac{1}{R_1}$$

$$-8R_1 = 1725$$

$$R_1 = -215.625\Omega$$

25.

$$R_t = R_1 + R_2$$

$$21 = 13 + R_2$$

$$8 = R_2$$

$$R_2 = 8\Omega$$